

This Owner's Manual is provided and hosted by [Appliance Factory Parts](#).



# George Foreman SK0010B Owner's Manual

[Shop genuine replacement parts for George Foreman  
SK0010B](#)



[Find Your George Foreman Small Appliance Parts - Select From 306 Models](#)

----- Manual continues below -----



# *Skillite*<sup>™</sup> SEARING SKILLET

**GEORGE FOREMAN**  
HEALTHY COOKING

***CUSTOMER CARE LINE:***

USA/Canada 1-800-231-9786

Accessories/Parts (USA/Canada)

1-800-738-0245

For online customer service  
and to register your product,  
go to [www.prodprotect.com/applica](http://www.prodprotect.com/applica)

***3-YEAR LIMITED WARRANTY***

Find additional healthy recipes at  
[www.georgeforemancooking.com](http://www.georgeforemancooking.com)

MODEL



***SK0010B***

# IMPORTANT SAFEGUARDS

When using electrical appliances, basic safety precautions should always be followed, including the following:

- Read all instructions.
- Do not touch hot surfaces. Use handles or knobs.
- To protect against electric shock do not immerse cord, plugs or appliance in water or other liquid.
- Close supervision is necessary when any appliance is used by or near children.
- Unplug from outlet when not in use and before cleaning. Allow to cool before putting on or taking off parts, and before cleaning the appliance.
- Do not operate any appliance with a damaged cord or plug, or after the appliance malfunctions or has been damaged in any manner. Return appliance to the nearest authorized service facility for examination, repair or adjustment. Or, call the appropriate toll-free number on the cover of this manual.
- The use of accessory attachments not recommended by the appliance manufacturer may cause injuries.
- Do not use outdoors.
- Do not let cord hang over edge of table or counter, or touch hot surfaces.
- Do not place on or near a hot gas or electric burner, or in a heated oven.
- Extreme caution must be used when moving an appliance containing hot oil or other hot liquids.
- Always attach plug to appliance first, then plug cord into wall outlet. To disconnect, turn any control to OFF (0), then remove plug from wall outlet.
- Do not use appliance for other than intended use.
- To reduce the risk of fire, cook only in provided container.

## SAVE THESE INSTRUCTIONS.

This product is for household use only.

### POLARIZED PLUG (120V Models Only)

This appliance has a polarized plug (one flat blade longer than the other) to reduce the risk of electric shock, this plug will fit in a standard wall outlet only one way. If the plug does not fit, do not use the appliance with the plug. If it still does not fit, contact a qualified electrician to modify the plug in any way.

### TAMPER-RESISTANT SCREW

**Warning: This appliance is equipped with a tamper-resistant screw to prevent removal of the outer cover. To prevent electric shock, do not attempt to remove the cover. No user-serviceable parts inside. Repair must be done by a qualified service personnel.**

### ELECTRICAL CORD

- a) A short power-supply cord (or detachable power-supply cord) should be provided to reduce the risk resulting from in or tripping over a longer cord.
- b) Longer detachable power-supply cords may be used if care is exercised in their use.
- c) If a long detachable power-supply cord is used:
  - 1) The marked electrical rating of the cord or extension cord should be at least equal to the rating of the appliance,
  - 2) If the appliance is of the grounded type, the cord should be a grounding-type 3-wire cord, and
  - 3) The longer cord should be arranged so that it does not drape over the countertop or tabletop where it can be pulled over.

**Note:** If the power supply cord is damaged, it should be replaced by a qualified service personnel; in Latin America, by an authorized service center.

Product may vary slightly from what is illustrated.

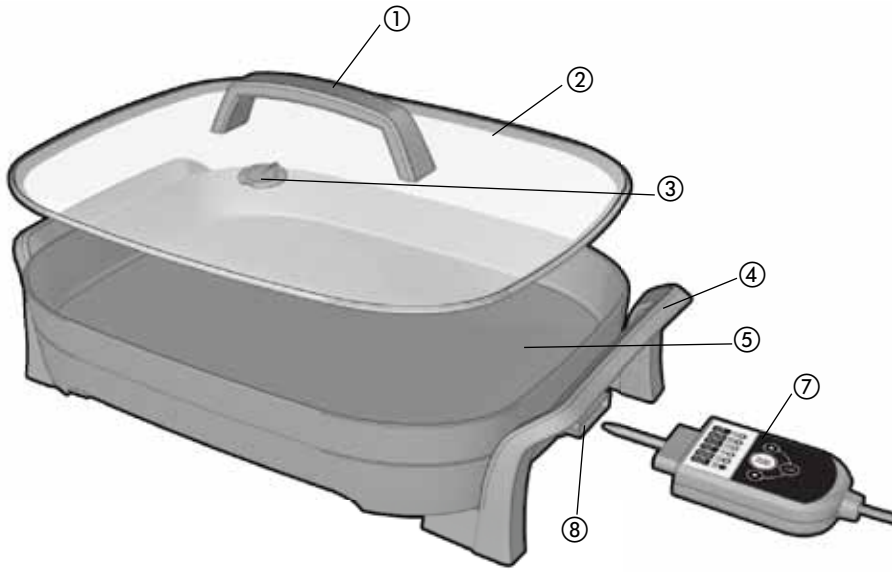

- 1. Lid handle
  - † 2. Tempered glass lid (Part # SK0010B-01)
  - 3. Steam vent
  - 4. Pan handles (both sides)
  - † 5. Cooking pan (Part # SK0010B-02)
  - 6. Grease channel (at front inside pan)
  - † 7. Intelli-Probe™ digital controls (Part # SK0010B-03)
  - 8. Probe socket
- Note: † indicates consumer replaceable/removable parts

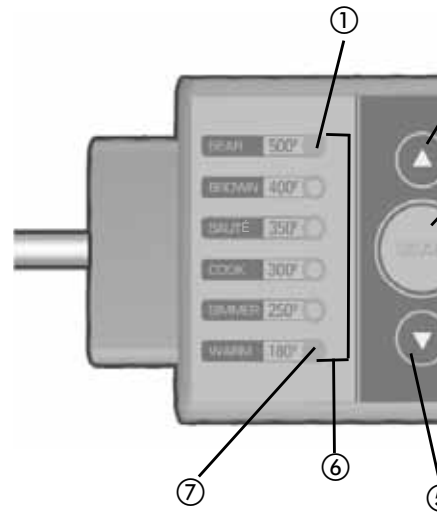

- 1. SEAR indicator light
- 2. Temperature ▲ button
- 3. SEAR button
- 4. ON/OFF button
- 5. Temperature ▼ button
- 6. Temperature indicator lights
- 7. WARM indicator light

# How to Use

This product is for household use only.

## GETTING STARTED

- Remove all packing material and, if applicable, any stickers from the product; remove and save literature.
- Please go to [www.prodprotect.com/applica](http://www.prodprotect.com/applica) to register your warranty; for additional information go to [www.georgeforemancooking.com](http://www.georgeforemancooking.com).
- Wash all removable parts and/or accessories as instructed in CARE AND CLEANING.
- Select a dry, level location where your grill will be used, leaving enough space between the back of grill and wall to allow heat to flow without damage to cabinets and walls.

**Important: This product is not a fryer. Do not cook with more than 1 – 2 tbsp. of oil or other fat at a time.**

## USING THE INTELLI-PROBE™ DIGITAL CONTROLS

1. Insert the control probe firmly into the probe socket.

**Important: Be sure the control is securely inserted.**

2. Uncoil cord and plug into standard electrical outlet.

**Note:** Always attach the control to the pan before plugging into an outlet.

3. Press the ON/OFF button.
4. Select the desired temperature setting based on what you would like to prepare. (See GENERAL TEMPERATURE RANGES for recommendations.)

## USING THE GREASE CHANNEL

There is a shallow channel at the front of the skillet. As food is browning, use a rubber spatula to direct the drippings into the channel. This feature allows you to separate grease and oils from browned and seared foods before adding any sauce ingredients, for healthier meals.

After separating the grease and oils, there are 2 ways to remove them from the channel:

- Use a bulb baster.
- Remove the browned food from the skillet. Using pot holders, pour the drippings into a container.

## USING YOUR SKILLET

1. Set temperature to desired temperature setting or according to your recipe. The indicator light will flash next to the selected temperature.
2. When the selected temperature is reached, the light becomes constant.

**Note:** During cooking the light will turn on and off, indicating the temperature is maintained.

3. When finished cooking, set temperature control to WARM to keep food at serving temperature or OFF before unplugging.

4. Use silicone, rubber or wood utensils when using metal utensils, be careful not to scrape the non-stick surface.

**Important: This product is not a fryer. Do not cook with more than 1 – 2 tbsp. of oil or other fat at a time.**

**Caution: Do not cut food in the skillet. This product is not a slicer.**

## GENERAL TEMPERATURE RANGES

### Warming - 180°F / WARM

Used to keep foods that have been prepared for a short period of time.

### Low Heat – 250°F / SIMMER

Use for simmering, steaming, and gentle boiling. Use for cooking special dessert sauces, such as Bananas Foster.

### Medium Heat – 300°F / COOK

Use for eggs, bacon and sausage. Also to cook foods that have been browned at higher temperatures.

### Medium-High Heat – 350°F / SAUTÉ

Use to sauté vegetables such as onions, green onions, etc.

### High Heat – 400°F / BROWN

Use to brown, pan fry and pan broil meats and breaded foods such as vegetables, meats, fish, etc. Use with a small quantity of oil.

### Searing - 500°F / SEAR

Use to quickly brown meats at high temperatures. When preheated to this setting, the skillet will sear food. If longer searing is needed, press the SEAR button.

## USING THE SEAR FUNCTION

This unique feature allows you to sear meat and vegetables for 3 minutes at a high temperature and then return to the original setting to continue cooking.

1. Begin preheating by setting your desired temperature.
2. Press the SEAR button on the digital control panel. The skillet to 500°F. The light next to SEAR will begin flashing.
3. When the skillet has reached the SEAR temperature, the light will become constant. It will hold that temperature for 3 minutes.

**Note:** It is not necessary to wait for the skillet to reach 500°F before selecting SEAR.

4. Carefully place food to be seared into the skillet. Cook for about 1½ minutes.
5. After about 3 minutes, the temperature control will return to the preset temperature initially selected. After SEAR, the skillet will return to 350°F.

**Note:** You can turn off SEAR by pressing the SEAR button. The skillet will automatically revert to the preset temperature.

6. If you have more food to sear, press the SEAR button again and follow steps 2 through 5.
7. When finished searing, you can add more food and continue cooking at your regular temperature or press the ON/OFF button and unplug the appliance if you are finished using the skillet.

## Care and Cleaning

This appliance contains no user-serviceable parts. Refer service to qualified service personnel.

### CLEANING

1. Unplug the cord and let skillet cool completely.
2. Make sure the digital control probe is removed.
3. To wash the cooking pan, fill with warm, sudsy water; scrub as needed, rinse, then dry thoroughly. The lid can be washed in the dishwasher, top-rack only.

**Important: Do not immerse the cooking pan in water. For hard stains, use a sponge or nylon scouring pad with liquid detergent.**

**Important: Do not use any abrasive cleaners or metal pads as they can damage the nonstick coating.**

4. Rinse and dry all parts thoroughly.
5. Wipe the cooking pan exterior base with a damp cloth and dry thoroughly.

### STORAGE

Store the skillet in a dry place and wind electric cord into a coil securing it with a twist tie.

TROUBLESHOOTING	
PROBLEM	POSSIBLE CAUSE
Finish on cooking pan is cut or scratched.	Metal utensils have been used.
Skillet smokes or has an odd odor on the first use.	This is normal on first use.
Skillet does not turn on.	Skillet is not plugged in or digital control probe is not inserted fully into probe socket.
Temperature does not register on the probe.	Skillet is not plugged in or digital control probe is not inserted fully into probe socket.

# Recipes

Find additional recipes for healthy, gourmet meals at [www.georgeforemancooking.com](http://www.georgeforemancooking.com)!

## SAUTÉED TILAPIA WITH GINGERED PINEAPPLE SAUCE

- 1 cup thinly sliced purple onion
- 1½ cups pineapple juice
- 2 tbsp. lime juice
- ½ cup halved seedless green grapes
- 1 orange, peeled, cut in half and sliced
- 1 cup cubed mango
- 2 tbsp. slivered orange peel
- 1 tbsp. grated fresh ginger
- ½ tsp. salt
- ¼ tsp. pepper
- 6 tilapia fillets (about 1½ lb.)
- 1 tbsp. cornstarch

Hot cooked rice

Heat skillet to 350°F. Cook onion for 3 minutes, stirring occasionally. Add 1¼ cups pineapple juice and lime juice. Stir in grapes, orange pieces, mango, orange peel, ginger salt and pepper. Cook 3 minutes longer, stirring occasionally.

Blend remaining ¼ cup pineapple juice with cornstarch. Stir into pineapple juice mixture and cook, stirring, until thickened and smooth. Remove to bowl and keep warm.

Raise temperature to 375°F. Cook fish until golden on both sides and fully cooked, pushing any grease or drippings into the grease channel. Remove grease and return sauce to skillet and heat through.

Serve over rice and garnish with sliced toasted almonds, if desired

Makes 6 servings.

## QUICK AND EASY CUBED STEAK

- 1½ lb. cubed beef
- 1 large onion, chopped
- 1 large green pepper, seeded and cut into strips
- 2 large cloves garlic, minced
- 1 tsp. Adobo seasoning
- 1 tsp. salt
- ½ tsp. coarse ground pepper
- 2 large tomatoes, cut into wedges
- 1 can (8 oz.) tomato sauce

Hot cooked rice

Chopped parsley

Heat skillet to 400°F. Brown beef on both sides over the grease channel. Allow to cook several minutes; keep warm; empty drippings from grease channel.

Add onion, green pepper and garlic to skillet and sauté for 5 minutes. Add coarse ground pepper. Cook until vegetables are tender. Stir in tomatoes.

Add tomato sauce and return meat to skillet. Cover and let simmer for 5 minutes; stir occasionally.

Serve over hot cooked rice and garnish with parsley.

Makes 4 servings.

### SAUTÉED SHRIMP WITH PESTO

2½ lb. shrimp

1 large Vidalia onion, halved and thinly sliced

1 large red pepper, seeded and cut into 2-inch strips

3 large cloves garlic, minced

1 bottle (8 oz.) clam juice

½ cup fresh lemon juice

2 tbsp. jarred traditional basil pesto

2 tbsp. grated lemon peel

1 bay leaf

1 tsp. salt

½ tsp. coarse ground pepper

Hot cooked rice

Chopped parsley

Shell shrimp, leaving tail on and de-vein. Refrigerate until ready to use.

Heat skillet to 350°F. Cook onion for 3 minutes, stirring occasionally. Add red pepper and garlic. Cook 3 minutes longer, stirring occasionally.

Add next 7 ingredients. Stir in shrimp. Bring to a boil. Reduce heat to 250°F. Cover and let simmer for 5 minutes or until shrimp are fully cooked; stir occasionally.

Serve over rice and garnish with parsley, if desired.

Makes about 8 servings.

### PORK 'N SALSA STEW

2½ lbs. boneless pork loin, cut in ¾-inch cubes

2½ cups chicken broth

1 cup salsa

2 tbsp. tomato paste

2 large cloves garlic, minced

½ tsp. ground cumin

½ tsp coarse ground pepper

1 bag (16 oz.) frozen shelled edamame

1 bunch green onions, cut in 1½-inch pieces

2 tbsp. cornstarch

Hot cooked rice

Coarsely chopped cashews

Heat skillet to 400°F. Add pork and brown with drippings into the grease channel. Remove and add chicken broth and next 5 ingredients. Bring to a boil.

Reduce heat to 250°F. Cover and let simmer for 10 minutes until edamame and green onions are tender.

Blend remaining ½ cup chicken broth with cornstarch. Stir cornstarch mixture into skillet and cook for 2 minutes.

To serve, spoon over rice and garnish with cashews.

Makes 6 to 8 servings.

**NEED HELP?**

For service, repair or any questions regarding your appliance, call the appropriate 800 number on cover of this book. Please DO NOT return the product to the place of purchase. Also, please DO NOT mail product back to manufacturer, nor bring it to a service center.

You may also want to consult the website listed on the cover of this manual.

**Three-Year Limited Warranty  
(Applies only in the United States and Canada)****What does it cover?**

- Any defect in material or workmanship provided; however, Aplica's liability will not exceed the purchase price of product.

**For how long?**

- Three years from the date of original purchase with proof of such purchase.

**What will we do to help you?**

- Provide you with a reasonably similar replacement product that is either new or factory refurbished.

**How do you get service?**

- Save your receipt as proof of date of sale.
- Check our on-line service site at [www.prodprotect.com/aplica](http://www.prodprotect.com/aplica), or call our toll-free number, 1-800-231-9786, for general warranty service.
- If you need parts or accessories, please call 1-800-738-0245.

**What does your warranty not cover?**

- Damage from commercial use
- Damage from misuse, abuse or neglect
- Products that have been modified in any way
- Products used or serviced outside the country of purchase
- Glass parts and other accessory items that are packed with the unit
- Shipping and handling costs associated with the replacement of the unit
- Consequential or incidental damages (Please note, however, that some states do not allow the exclusion or limitation of consequential or incidental damages, so this limitation may not apply to you.)

**How does state law relate to this warranty?**

- This warranty gives you specific legal rights, and you may also have other rights that vary from state to state or province to province.

Made in People's Republic of China  
Printed in People's Republic of China



*Cook what you love, only healthier*



© 2010 Applica Consumer Products, Inc.

2010/3-15-38E