

# Model 852B

Catalog 852-04-10  
(3 Gal. dry)

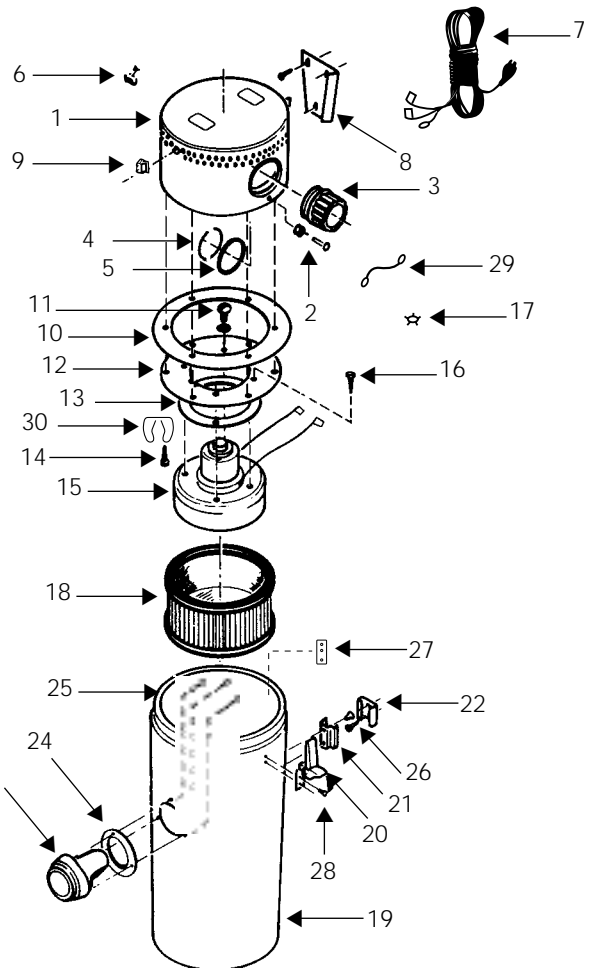

ITEM	DESCRIPTION	PART NO.
1	Head cover assembly	83226-96
2	Clamp post	83204-00
3	Exhaust fitting	00449-00
4	Retaining ring	36002-99
5	Gasket	83234-00
6	Strain relief	34002-99
7	Power cord	04237-96
8	Wall bracket	91600-00
9	Switch	82319-00
10	Gasket	83210-00
11	#10 - 24 x 1/2" lg. ground screw	17008-99
12	Motor mounting plate	83208-20
13	Gasket	56300-00
14	#10 x 1/2" Type A hex head screw	15061-99
15	Motor	14906-97
16	Screw #8 -10 x 5/8", PH pan head	15917-00
17	Star washer	23001-99
18	Cartridge filter	90319-00
19	Tank assembly	83250-99
20	Clamp	28100-00
21	Tank wall clip	83202-00
22	Wall clip	83203-00
23	Inlet	21720-01
24	Gasket	00490-00
25	#10 x 3/4" - Type BF hex head screw	15033-99
26	#10 x 1 1/2" - Type AB Screw	15042-99
27	Backing plate	83238-00
28	Rivet	03024-99
29	Ground lead	42228-96
30	Spacer	83240-00

**Standard Accessories:**

- 18' (5.49 m) x 1 1/4" (3.18 cm) Hose
- (2) 1 1/4" (3.18 cm) Extension wands
- 6" (15.24 cm) Master nozzle
- 6" (15.24 cm) Brush shoe
- 1 1/4" (3.18 cm) Crevice tool
- 1 1/4" (3.18 cm) Round brush
- Wall mounting bracket

**Limited One-Year Warranty**

Shop-Vac Corporation warrants all Industrial, Commercial, and Contractor vacuum cleaners for one year from date of purchase to correct by repair or parts replacement without charge any product defect due to faulty material or workmanship, provided that the vacuum cleaner is not used for rental service.