

shop-vac®

Model 90L600

Catalog 9301611 LOWES
(16 Gal.)

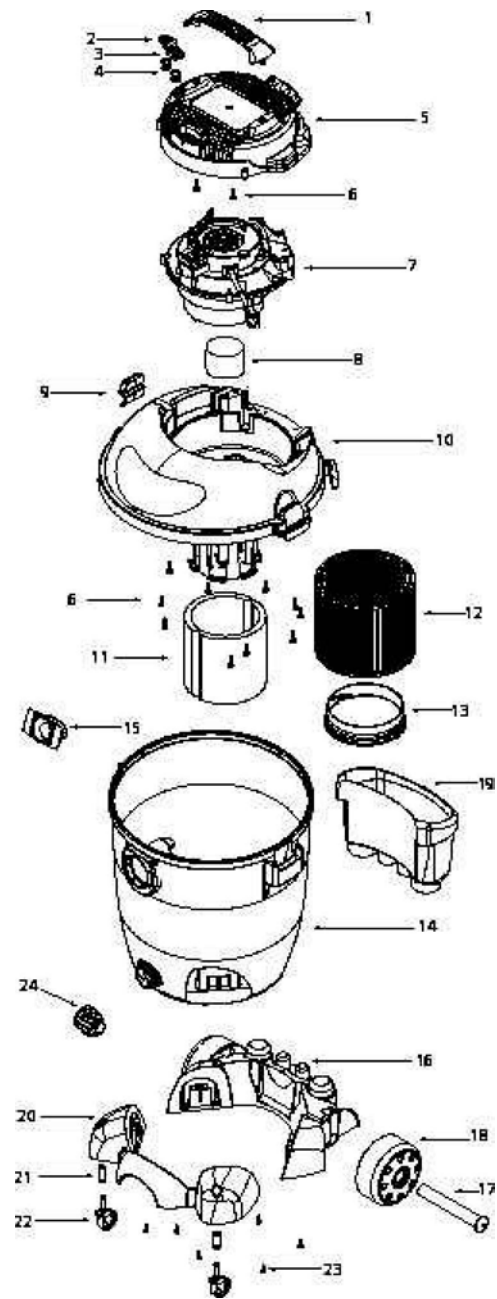

ITEM	DESCRIPTION	
1	Handle	
2	Switch Button - Red	
3	Switch Button - Green	
4	Spring	
5	Motor Cover Assembly	
6	Screw 10 x 3/4" Trilobe T25 Head	
7	Power Unit Assembly	
8	Float	
9	Lid Latch	
10	Lid Cage and Latch Assembly	
11	Foam Sleeve	
12	Cartridge Filter (Includes item 13)	
13	Filter Retainer	
14	Tank Assembly	
15	Inlet Deflector	
16	Rear Wheel Dolly/Tool Holder	
17	Axle	
18	Rear Wheel	
19	Accessory Basket	
20	Front Caster Dolly	
21	Retainer	
22	Caster	
23	Screw 10 x 3/4" SL Hex Head	
24	Drain Cover	

STANDARD ACCESSORIES

- 8' x 2-1/2" hose
- 2 - 2-1/2" extension wands
- 14" floor nozzle w/brush

- 14" squeegee insert
- 2-1/2" crevice tool
- 8" utility nozzle
- hose holder

FIVE-YEAR HOME USE WARRANTY - SATISFACTION GUARANTEED

Your Shop-Vac® vacuum cleaner is warranted in normal household use, in accordance with the User Manual, against original defects in material and workmanship for a period of five years from date of purchase. Should this product be used for commercial or rental use, a 90 day limited warranty will apply. Shop-Vac Corporation warrants placing this vacuum cleaner in correct operating condition, by repair or parts replacement, during the warranty period, without charge. This warranty does not cover accessories. Use of non-recommended filters and/or accessories may void the manufacturer's warranty.

SC87528-42