

This Owner's Manual is provided and hosted by [Appliance Factory Parts](http://www.appliancefactoryparts.com).

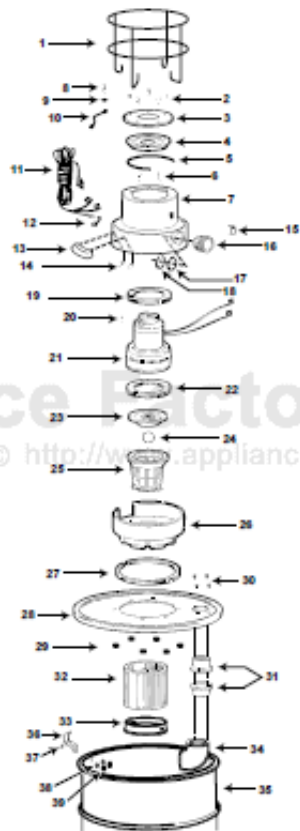

# Shop Vac 984B Owner's Manual

[Shop genuine replacement parts for Shop Vac 984B](#)



[Find Your Shop Vac Vacuum Cleaner Parts - Select From 487 Models](#)

----- Manual continues below -----

# Model 984B

Catalog 9840310 (55 Gal.)  
9840410 (55 Gal. head only)

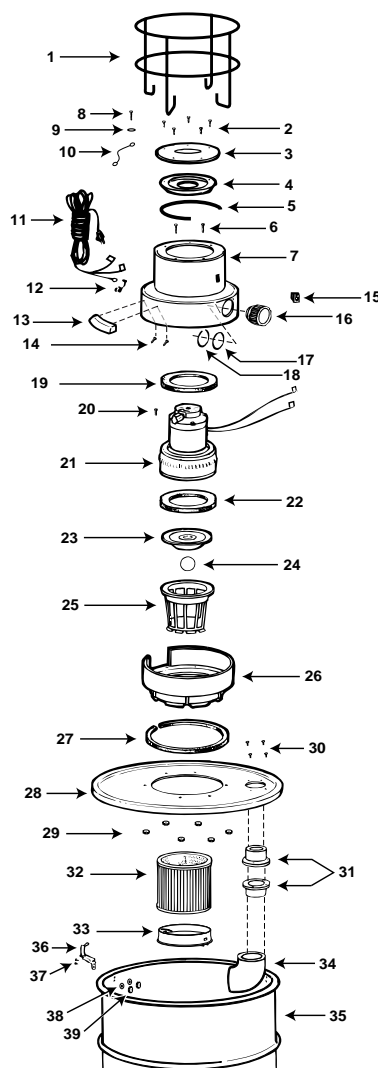

**Standard Accessories:**  
12' (3.66 m) x 1 1/2" (3.81 cm)  
Hose  
6" (15.24 cm) Metal gulper  
nozzle  
Hose carrier

ITEM	DESCRIPTION	PART NO.
1	Hose carrier	0064900
2	#12 x 1/2" AB PH pan head screw	1505099
3	Motor cover	9936400
4	Motor mounting plate	9936010
5	Strip gasket	2071106
6	Motor mounting screw #8-10 x 5/8" PH	1591700
7	Motor housing	9860996
8	#10 x 1/2" Hex head screw, type AB	1506199
9	Internal tooth lockwasher	2300499
10	Ground lead	4222896
11	Power cord	0423496
12	Strain relief bushing	3400499
13	Handle pkg. (includes 2 handles and hardware)	9355196
14	#10 x 3/4" Slotted hex head screw, type AB	1503999
15	Switch	8231900
16	Exhaust fitting	8460000
17	Gasket O-ring	8323400
18	Retaining ring	3600299
19	Mid motor gasket	5630000
20	Ground screw	1700899
21	Motor	1349697
22	Motor gasket	2072100
23	Grid plate	8940010
24	Ball float	0081100
25	Filter cage	8790100
26	Lid adapter	8988001
27	Strip gasket	2071102
28	Cover	3140500
29	#10 - 24 Hex nut, washer base	1302299
30	#10 x 5/8" Slotted hex head screw, type BF	1505499
31	Flange ferrule	2340100
32	Cartridge filter	9030462
33	Filter retainer	3008000
34	Inlet elbow	0910400
35	Tank assembly (55 gal.)	3120496
36	Clamp	6550000
37	6 - 32 x 1/2" Machine screw	0807699
38	Split lockwasher	0200499
39	6-32 Hex nut	1300599

ITEM	DESCRIPTION	PART NO.
1	55 Gal. band assembly	0063396
2	Caster	6771400
3	Machine screw, 1/4 - 20 x 1 3/4"	0807399
4	Hex nut, 1/4 - 20	1300199

### Band Dolly Assembly

1. Place casters into sockets on band assembly.
2. Place tank upside down and slip band assembly over lip on bottom of tank.
3. Insert bolt and tighten nut until secure.

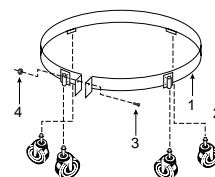

### Limited One-Year Warranty

Shop-Vac Corporation warrants all Industrial, Commercial, and Contractor vacuum cleaners for one year from date of purchase to correct by repair or parts replacement without charge any product defect due to faulty material or workmanship, provided that the vacuum cleaner is not used for rental service.