

Model C75A

Catalog 75001-10
(25 Gal.)

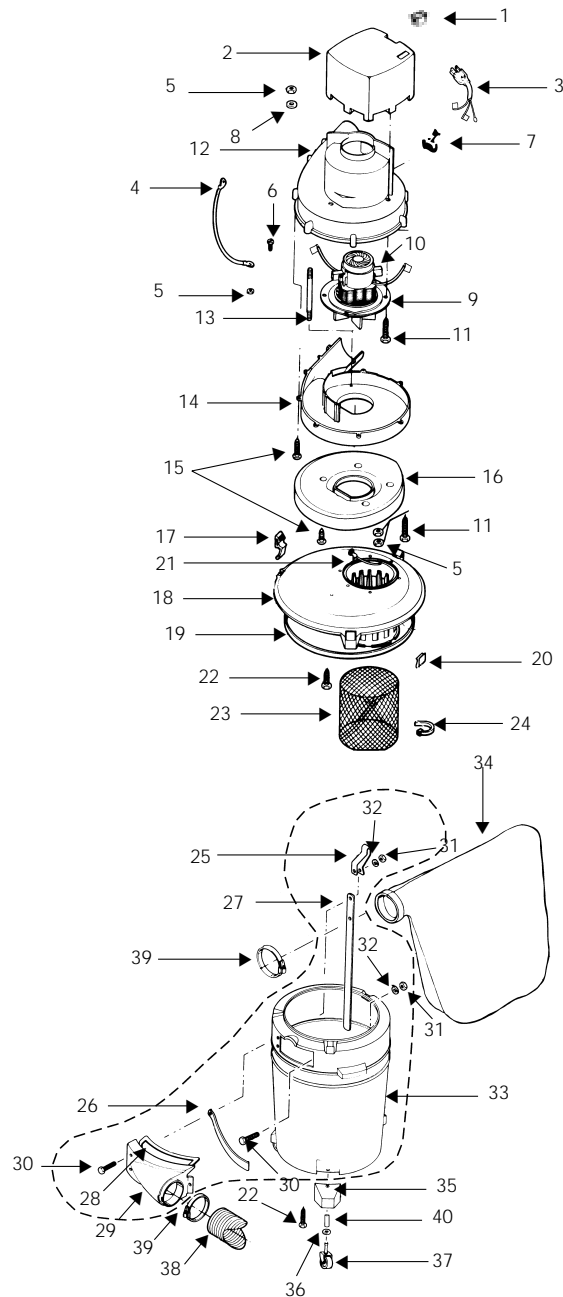

ITEM	DESCRIPTION	PART NO.
1	Switch	82319-00-5
2	Cover	82905-06-8
3	Cord	04237-96-2
4	Ground lead	42228-96-5
5	#10 -24 hex nut	13009-99-8
6	#10 -24 x 1/2" type F ground screw	17008-99-6
7	Strain relief bushing	34004-99-4
8	#10 flat washer	07001-99-3
9	Motor/fan assembly	14975-97-3
10	Motor brushes	13509-96-3
11	1/4 x 1 1/4" slotted hex head screw type AB	15018-99-7
12	Blower housing - upper	82901-04-2
13	Mounting stud	01207-00-0
14	Blower housing - lower	82902-00-8
15	#10 x 3/4" phillips pan head screw type AB	15060-99-7
16	Adapter	82927-00-5
17	Latch	85501-01-3
18	Lidcage & latch assembly	89890-14-9
19	Static ground ring	82980-00-4
20	U-clip	72002-99-1
21	U-clip & lead wire assembly	82988-96-5
22	#10 x 3/4" slotted hex head screw type AB	15039-99-3
23	Screen	82929-01-9
24	Wire tie	00422-01-4
25	Static ground strap	82983-00-8
26	Static ground inlet strap	82982-00-0
27	Static ground tank strap	82981-00-2
28	Gasket	82933-00-3
29	Inlet	82928-00-3
30	1/4" - 20 x 1" hex head machine screw	09031-99-8
31	1/4" lock washer	02002-99-6
32	1/4" hex nut	13001-99-5
33	Tank assembly	82970-97-1
34	Bag	82940-27-1
35	Caster foot	85651-00-8
36	Flatwasher	07043-99-5
37	Caster	67736-00-9
38	4" (10.16 cm) x 12 ft (3.66 m) Hose	82939-00-0
39	Metal clamp	81001-99-2
40	Retainer	85656-00-7

Standard Accessories:
12' (3.66 m) x 4" (10.16 cm) Hose
(2) Hose clamps

Limited One-Year Warranty

Shop-Vac Corporation warrants all Industrial, Commercial, and Contractor vacuums for one year from date of purchase to correct by repair or parts replacement without charge any product defect due to faulty material or workmanship, provided that the vacuum cleaner is not used for rental service.