

H87 Series

Model H87S550A

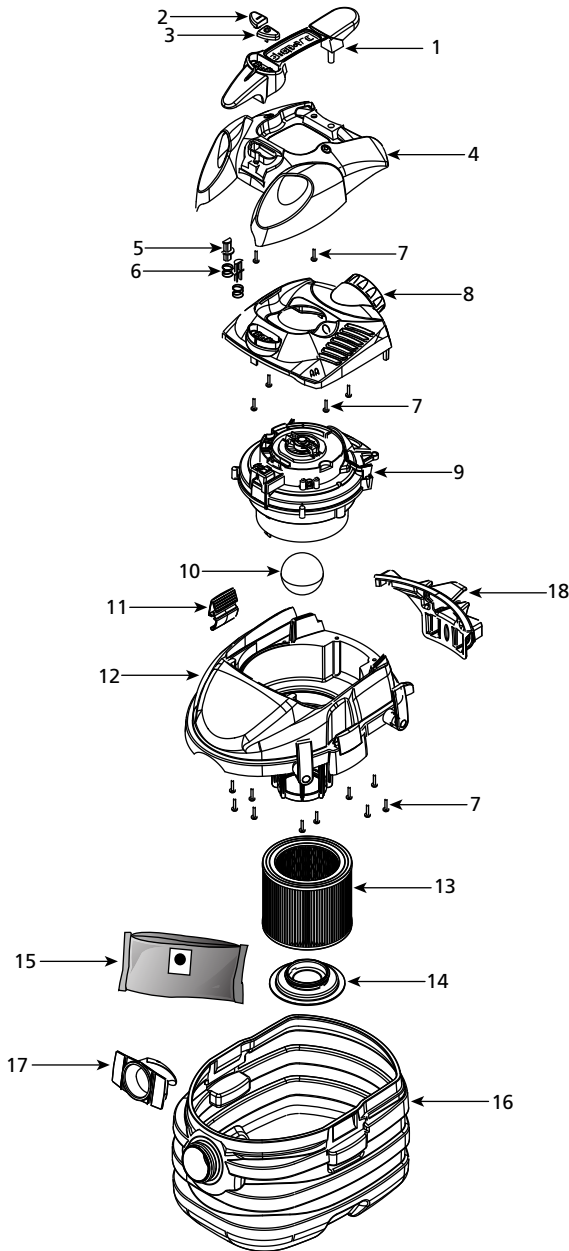

ITEM ARTICULO	DESCRIPTION DESCRIPCION	PART NO. PIEZA NO.
1	Handle	3549022
2	Switch Button - On	7414205
3	Switch Button - Off	7414215
4	Outer Motor Cover Assembly	3549202
5	Switch Button E tension	7414250
6	Spring	2802899
7	Screw 10 3/4" Trilobe T25 Head	1517699
8	Inner Motor Cover Assembly	1944359
9	Power Unit Assembly	8136997
10	Ball Float	0081100
11	Lid Latch	7444502
12	Lid Cage & Latch Assembly	1944445
13	Cartridge Filter	9039800
14	Filter Retainer	3183000
15	Collection Filter Bag	9066100
16	Tank Assembly	1092397
17	Inlet Deflector	7413100
18	Tool Holder	3755602

* Replacement parts may differ from original equipment.

THREE-YEAR HOME USE WARRANTY

Your Shop-Vac® vacuum cleaner is warranted in normal household use, in accordance with the User Manual, against original defects in material and workmanship for a period of three years from date of purchase. Should this product be used for commercial or rental use, a 90 day limited warranty will apply. Shop-Vac Corporation warrants placing this vacuum cleaner in correct operating condition, by repair or parts replacement, during the warranty period, without charge. This warranty does not cover accessories. Use of non-recommended filters and/or accessories may void the manufacturer's warranty. For product service contact Shop-Vac Corporation, Customer Service, at () 36-357 or e-mail service@shopvac.com. Shop-Vac assumes no responsibility for damage or faulty performance caused by misuse or careless handling, or where repairs or modifications have been made or attempted by others. Proof of purchase date is required. This warranty gives you specific legal rights, and you may also have other rights, which vary from state to state. This warranty is void outside of the United States.