

Model QL400D

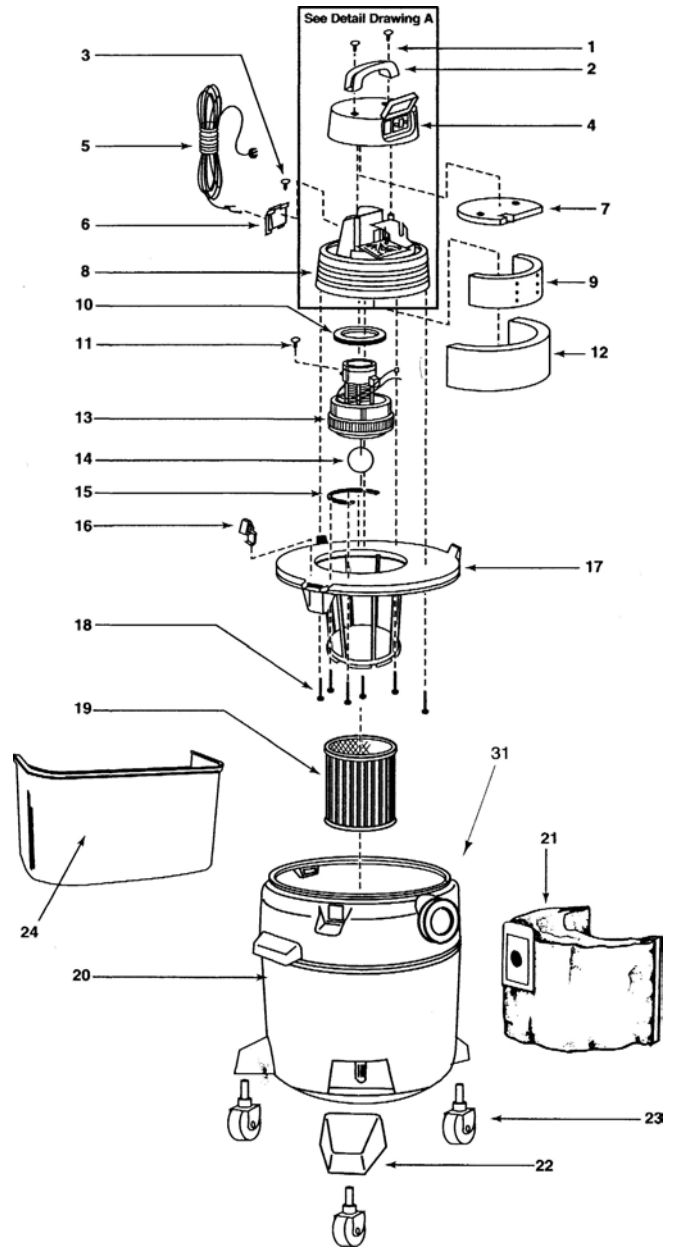

Detail Drawing A

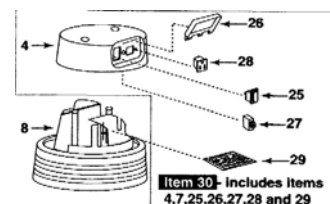

Item 30 - Includes Items 4,7,25,26,27,28 and 29

ITEM	DESCRIPTION	PART NO.
1	Screw truss head 1/4 x 3/4 type AB	
2	Top handle	
3	Screw #8 x 1/2 Ph pan hd type AB	
4	Motor housing cover	
5	Cord	
6	Cord retainer	
7	Foam insert cover	
8	Motor housing	
9	Inner housing acoustical foam	
10	Upper motor gasket	
11	#10-24 x 1/2" lg. Ground screw	
12	Outer housing, acoustical foam	
13	†Motor w/TCO	
14	Ball float	
15	Strip gasket	
16	Latch	
17	Lid cage assembly	
18	#10 x 3/4 screw	
19	Cartridge filter	
20	Tank assembly	
21	Collection filter bag (pkg of 5)	
22	Caster foot	
23	Caster	
24	Accessory caddy	
25	Double pole rocker switch	
26	Cover w/labels	
27	Circuit breaker	
28	Receptacle	
29	Circuit board assembly	
30	Cover w/items (4,7,25,26,27,28,&29)	
31	Drain Cap	

(†) Motor brushes No. 15999-00-6