

This Owner's Manual is provided and hosted by [Appliance Factory Parts](http://Appliance Factory Parts).

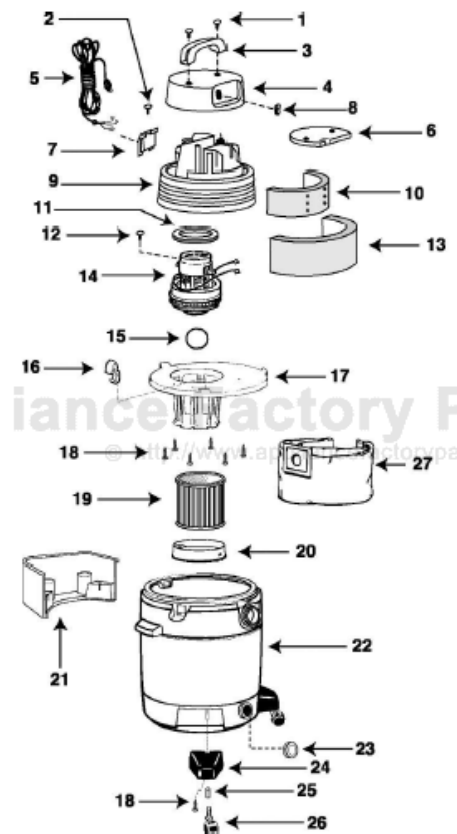

# Shop Vac QL30C-1C Owner's Manual

[Shop genuine replacement parts for Shop Vac  
QL30C-1C](#)



[Find Your Shop Vac Vacuum Cleaner Parts - Select From 487 Models](#)

----- Manual continues below -----

# Model QL30C-IC

Catalog 9254010  
(10 Gal.)

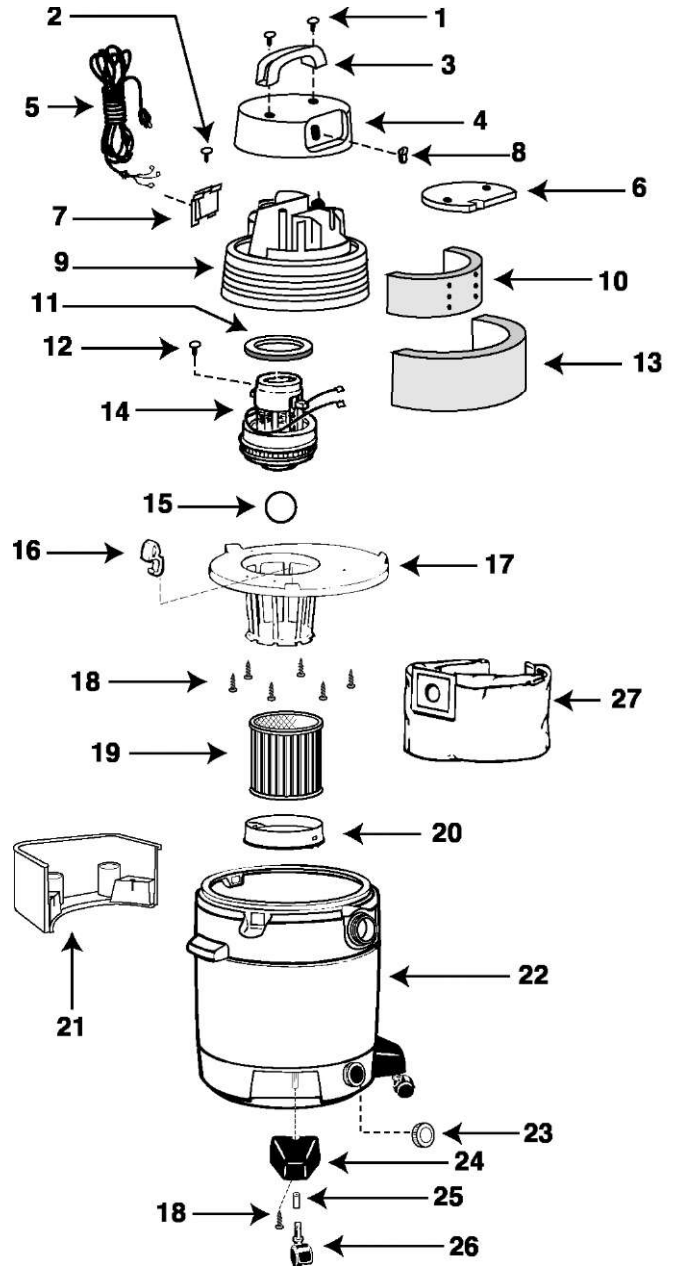

ITEM	DESCRIPTION	PART NO.
1	Screw Truss Head 1/4" x 3/4" Type AB	1514699
2	Screw #8 x 1/2" Ph Pan Hd Type AB	1500799
3	Handle	2410500
4	Motor Housing Cover	2410603
5	Cord	2580020
6	Foam Insert Cover	2412500
7	Cord Retainer	2411115
8	Switch	8231800
9	Motor Housing	2410768
10	Foam Motor Housing - Inner	1290400
11	Gasket - Upper Motor	2072000
12	Ground Screw #10 - 24 x 1/2" Type F	1700899
13	Foam Motor Housing - Outer	1290503
14	Motor	1817297
15	Ball Float	0081100
16	Lid Latch	8550101
17	Lid Cage & Latch Assembly	8967051
18	Screw Hex Head #10 x 3/4" Type AB	1503999
19	Cartridge Filter	9030462
20	Filter Retainer	3008000
21	Accessory Caddy	8564000
22	Tank Assembly	1047697
23	Drain Cap	1062020
24	Caster Foot	8565000
25	Caster Retainer	8565500
26	Caster	6774200
27	Collection Bag	9067262

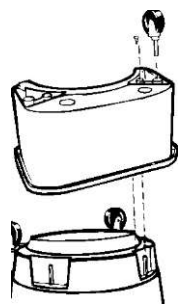

**Install casters and caddy as follows:**

1. With tank cover removed, invert tank so the bottom is facing up.
2. Insert two caster feet into adjacent slots at front of tank. Secure with screws.
3. Insert accessory caddy into remaining slots at back of tank. Secure with screws.
4. Insert casters into caddy and supports by inserting the caster stems into the holes provided and applying pressure until you feel the casters are firmly in place.

**STANDARD ACCESSORIES**

- 6' x 2 1/2" Locking hose
- 2 - 2 1/2" Extension wands
- 6" Utility nozzle
- 14" Floor nozzle
- 14" Squeegee insert
- 2 1/2" Crevice tool