

shop-vac®

Model - QL45A

Catalog 925-31 (12 Gal.)
925-32 (14 Gal.)

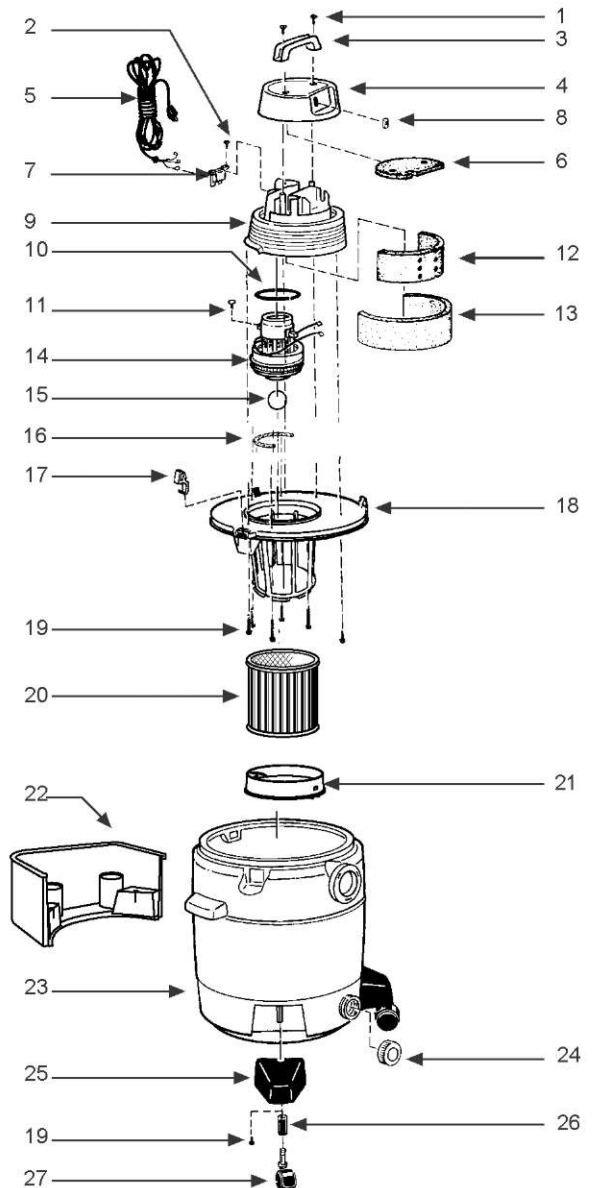

ITEM	DESCRIPTION	PART NO.
1	Screw Truss Head 1/4 x 3/4 Type AB	15146-99-6
2	Screw #8 x 1/2 Ph Pan Hd Type AB	15007-99-0
3	Handle	24105-00-9
4	Motor Housing Cover	24106-03-1
5	Cord	25800-20-2
6	Foam Insert Cover	24125-00-7
7	Cord Retainer	24111-15-5
8	Switch	82318-00-7
9	Motor Housing	24107-69-0
10	Gasket - Upper Motor	20720-00-9
11	Ground Screw #10-24 x 1/2 Type F	17008-99-6
12	Foam Motor Housing - Inner	12904-00-9
13	Foam Motor Housing - Outer	12905-03-0
14	Motor	18173-97-1
15	Ball Float	00811-00-0
16	Strip Gasket	20711-00-8
17	Lid Latch	85501-01-3
18	Lid Cage & Latch Assembly (12 Gal) (14 Gal)	89670-21-0 89887-14-5
19	Screw Hex Head #10 x 3/4 Type AB	15039-99-3
20	Cartridge Filter	90304-62-7
21	Filter Retainer	30080-00-4
22	Accessory/Tool Holder (12 Gal) (14 Gal)	85641-00-9 85642-00-7
23	Tank Assembly (12 Gal) (14 Gal)	10477-97-4 10478-97-2
24	Drain Cap	10620-20-1
25	Caster Foot (12 Gal) (14 Gal)	85650-00-0 85651-01-6
26	Caster Retainer (12 Gal)	85655-00-9
27	Casters (Pkg. of 4)	42017-96-2

Standard Accessories

- 7' x 11/4" hose with curved end and air diffuser
- 2 - 11/4" extension wands
- 10" wet/dry nozzle
- 10" squeegee insert
- 11/4" gulper nozzle
- 11/4" crevice tool
- 11/4" round brush

FOUR-YEAR HOME USE WARRANTY

Your Shop-Vac® vacuum cleaner is warranted in normal household use, in accordance with the User Manual, against original defects in material and workmanship for a period of four years from date of purchase. Should this product be used for commercial or rental use, a 90 day limited warranty will apply. Shop-Vac Corporation warrants placing this vacuum cleaner in correct operating condition, by repair or parts replacement, during the warranty period, without charge. This warranty does not cover accessories. Use of non-recommended filters and/or accessories may void the manufacturer's warranty.