

Model QL600D

Catalog 9256310
(12 gal.)

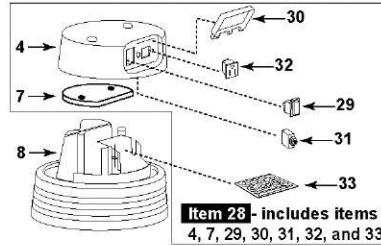

Detail Drawing A

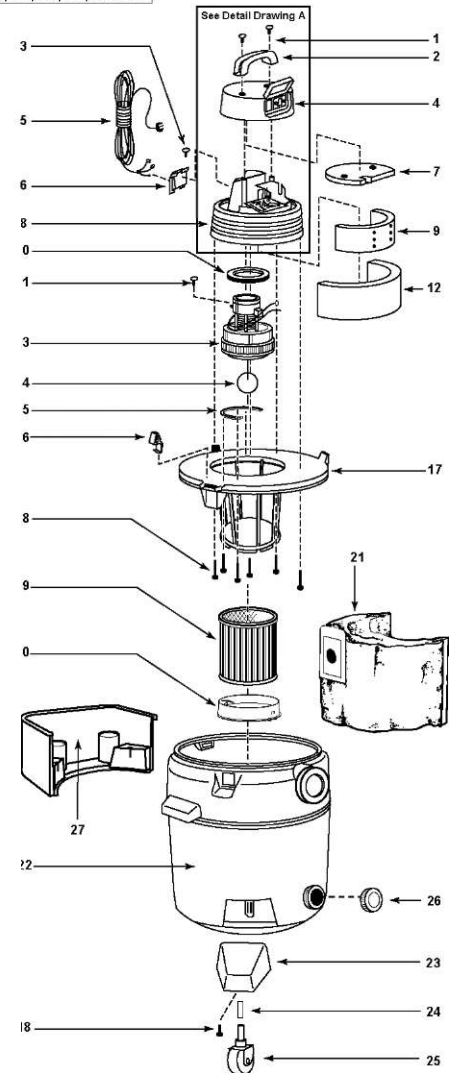

ITEM	DESCRIPTION	PART NO.
1	Screw truss head 1/4 x 3/4 type AB	1514699
2	Top handle	2410500
3	Screw #8 x V2 Ph pan hd type AB	1500799
4	Motor housing cover	2410602
5	Cord	2580001
6	Cord retainer	2411107
7	Foam insert cover	2412500
8	Motor housing	2410709
9	Inner housing acoustical foam	1290400
10	Upper motor gasket	2072000
11	#10-24 x 1/2" lg. Ground screw	1700899
12	Outer housing, acoustical foam	1290500
13	Motor w/TCO	1496397
14	Ball float	0081100
15	Strip gasket	2071100
16	Latch	8550101
17	Lid cage assembly	8965724
18	#10 x 3/4 screw	1503999
19	Cartridge filter	9030462
20	Filter retainer	3008000
21	Collection filter bag (pkg of 5)	9190610
22	Tank assembly	1046497
23	Caster foot	8565000
24	Caster retainer	8565500
25	Caster	6772200
26	Drain Cap	1062020
27	Accessory caddy	8564100
28	Cover w/items (4,7,29,30,31,32&33)	2410651
29	Double pole rocker switch	8231700
30	Cover w/labels	6195896
31	Circuit breaker	1210028
32	Receptacle	1210027
33	Circuit board assembly	6195697

(†) Motor brushes No. 15999-00-6

Standard Accessories:

- 12' x 1 1/2" Hose
- (2) 1 1/4" Extension wands
- 10" Combination nozzle
- Squeegee insert
- Dual surface selector nozzle

- 1 1/4" Round brush
- 1 1/4" Gulper nozzle
- 1 1/4" Crevice tool
- Universal tool adapter

LIMITED ONE-YEAR WARRANTY

Shop-Vac Corporation warrants the vacuum cleaner for one year from date of purchase to correct by repair or parts replacement without charge any product defect due to faulty material or workmanship provided that the vacuum cleaner is not used for rental service. This warranty does not cover accessories. Simply return the complete unit, (transportation prepaid), to the Authorized Shop-Vac Service Center nearest you. (A complete list of Authorized Shop-Vac Service Centers is included with each vacuum Cleaner.) Shop-Vac assumes no responsibility for damage or faulty performance caused by misuse or careless handling, or where repairs or modifications have been made or attempted by others. Proof of purchase date is required. This warranty gives you specific legal rights, and you may also have other rights which vary from state to state. This warranty is void outside of the United States.