

Model - QPS35

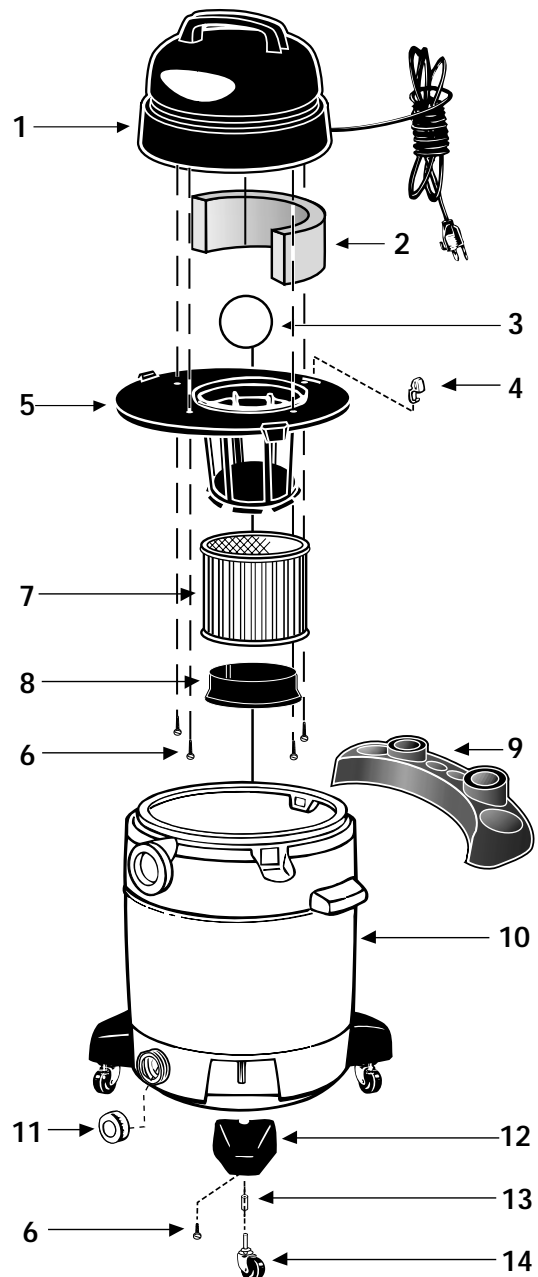

ITEM	DESCRIPTION	PART NO.
1	Power Unit Assembly	8117597
2	Foam Insert	1290506
3	Ball Float	0081100
4	Lid Latch	8550101
5	Lid Cage & Latch Assembly	8965724
6	Screw Hex Head #10 x 3/4 Type AB	1503999
7	Cartridge Filter	9030462
8	Filter Retainer	3008000
9	Accessory/ Tool Holder	8411100
10	Tank Assembly	8454797
11	Drain Cap	1062021
12	Caster Foot	8565000
13	Caster Retainer	8565500
14	Caster	6771200

STANDARD ACCESSORIES

- 8' x 1 1/4" hose with curved end
- 2 - 1 1/4" extension wands
- 10" wet/dry nozzle
- 10" squeegee insert
- Crevice tool
- Round brush
- Gulper nozzle

THREE-YEAR HOME USE WARRANTY

Your Shop-Vac® Brand vacuum cleaner is warranted in normal household use, in accordance with the user manual, against original defects in material and workmanship for a period of three years from date of purchase. Should this product be used for commercial or rental use, a 90 day limited warranty will apply. Shop-Vac Corporation warrants placing this vacuum cleaner in correct operating condition, by repair or parts replacement, during the warranty period, without charge. This warranty does not cover accessories. Use of non-recommended filters and/or accessories may void the manufacturer's warranty.