

This Owner's Manual is provided and hosted by [Appliance Factory Parts](#).

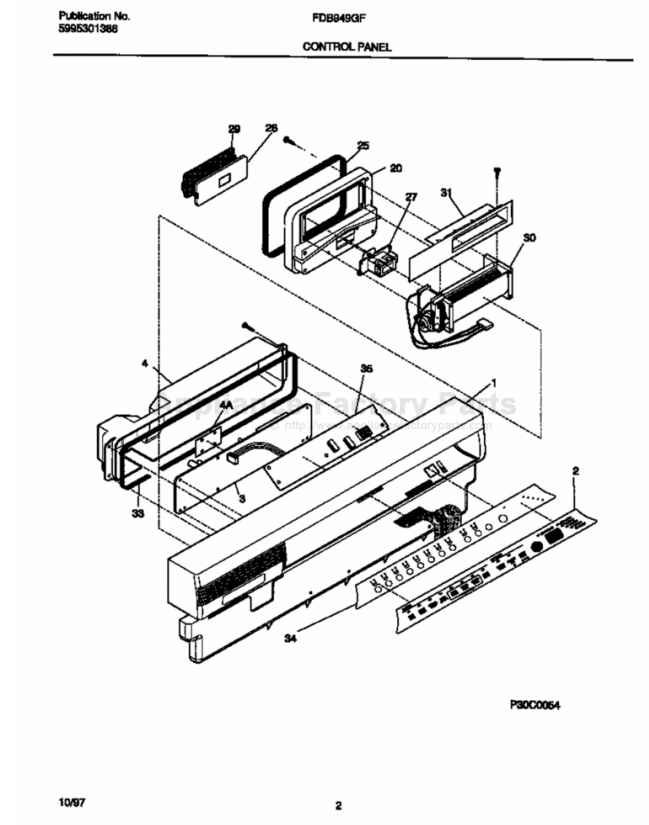

# Electrolux FDB949GFS1 Owner's Manual

[Shop genuine replacement parts for Electrolux  
FDB949GFS1](#)



[Find Your Electrolux Dishwasher Parts - Select From 406 Models](#)

----- Manual continues below -----

# Exploded View of Wash System

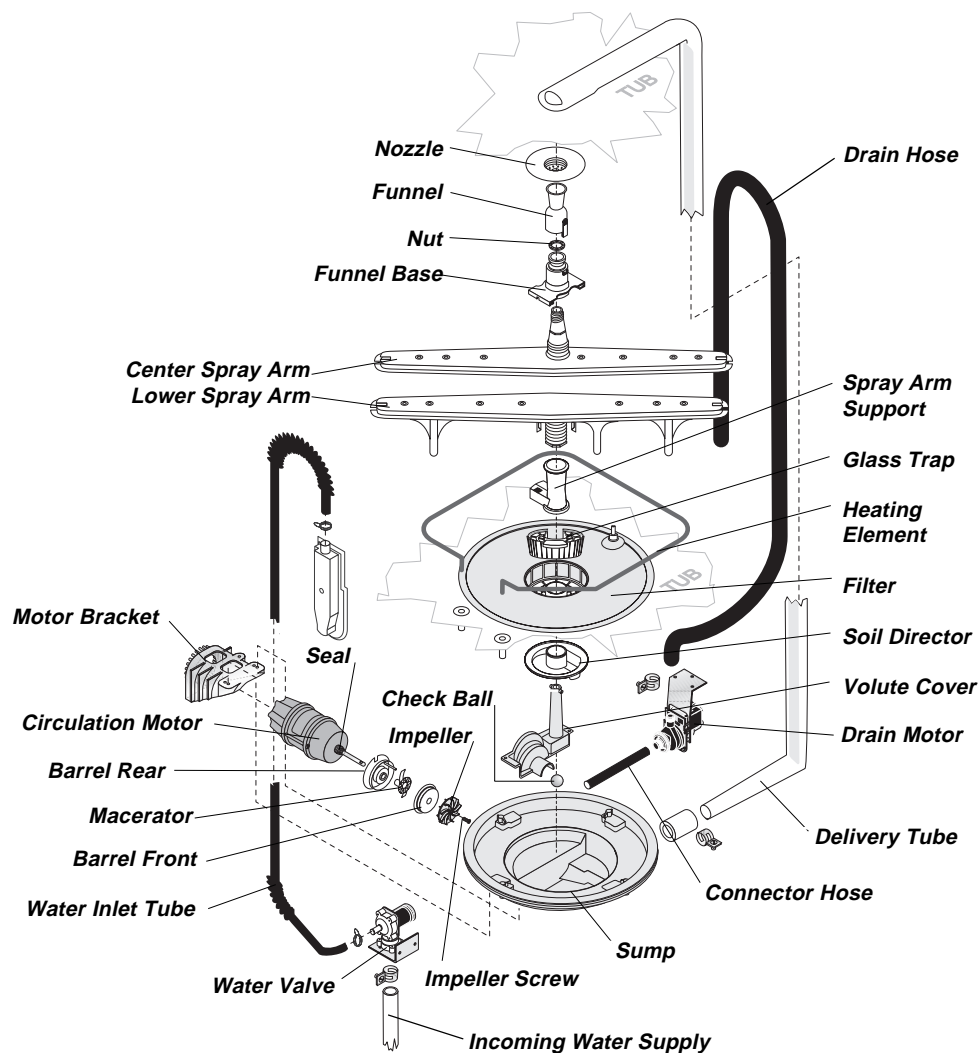

## Pump Assembly

The pump assembly is driven by a 1/12 HP, shaded pole motor. Rotation is in the counterclockwise direction at 3100 to 3200 RPM. The motor drives a pump which supplies 100 percent filtered water at a rate of approximately 12 GPM to one spray arm at a time. The spray arm's operation is alternated by small "pauses" of the motor during the wash cycle.

Draining is accomplished by using a small separate synchronous drain pump mounted to the side of the sump. The drain pump is connected to the main pump by a small rubber hose. The drain check valve is located at the entrance to the drain pump. The drain hose is attached by a worm gear clamp to the discharge of the drain pump. The drain is then routed up the side of the dishwasher and attached to the side of the tub. This drain loop insures that an air pocket cannot form near the drain pump and cause the pump to

air lock. The drain loop on the side of the tub must be kept in place after servicing.

The main pump can easily be removed by disconnecting the upper spray arm supply tube, the drain pump connector hose, and the wiring harness connections made at the circulation motor and the water heat thermistor located on the bottom of the pump.

Once the pump assembly is removed from the dishwasher, the motor/impeller assembly can be removed from the sump by taking out the three (3) T-20 Torx head screws from the aluminum motor bracket and then the three (3) T-20 Torx head screws from the volute cover. Using a large flat head screwdriver inserted between the impeller screw and the sump's volute, the motor/impeller assembly can be gently pried out of the sump. Use the screwdriver as a lever.

## 900 Watt Heater

Refer to the cycle chart on the reverse side to determine when the heater is on during the wash cycle. The heater cycles **ON** and **OFF** for brief periods during the drying cycle.

Voltage checks of the heater should be made in the dry portion of the service test mode.

## Standard Dry Air Flow

When the control advances to the "dry" portion of the cycle, a linear actuator retracts a valve, which opens a vent path through the console into the kitchen. This venting method eliminates discharging heated moisture into the moisture compartment. The heated, moist air leaving the dishwasher through the console vent causes drier air to be drawn into the unit by way of intake vents located at the bottom of the door. The water on the dishes is evaporated into drier air and the venting process continues. The heating element is turned **ON** and **OFF** during the end of the drying cycle.

## Detergent and Rinse Aid Dispenser

The detergent and rinse aid dispenser is a complete piece component consisting of a molded detergent cup and a built-in rinse aid dispenser.

The detergent cup has a spring loaded cover and the rinse aid dispenser has a removable cover.

Liquid rinse aid is added to the dispenser up to the fill line indicator. The amount of rinse aid released can be adjusted by turning the amount indicator from one, being the least amount, to four, being the greatest amount.

### To replace dispenser:

- shut off electricity to dishwasher,
- remove outer door panel assembly,
- disconnect wiring to the actuator,

## Tub and Door Seal

The door seal is pressed into the tub channel to form an interference fit. Center the gasket (marked with an arrow) at the tub top center and press in place.

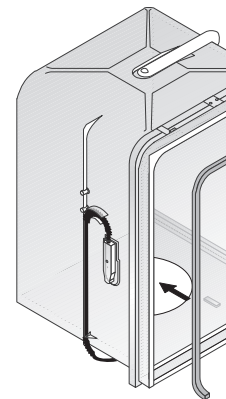

## Product Specifications

### Electrical

Rating .....	120 Volts, 60 Hz
Separate Circuit .....	.15 amp min.- 20 amp max.
Motor (HP) .....	1/12
Motor (Amps) .....	1.5
Heater Wattage .....	900
Total Amps (load rated) .....	1.5
TempAssure .....	140°F ±5°F (60°C ±3°C) [with outer door in place]
TempBoost .....	144°F ±5°F (62°C ±3°C) [Heated Wash/Heated Rinse]
Hi-Limit Thermostat .....	200°F (93°C)

