

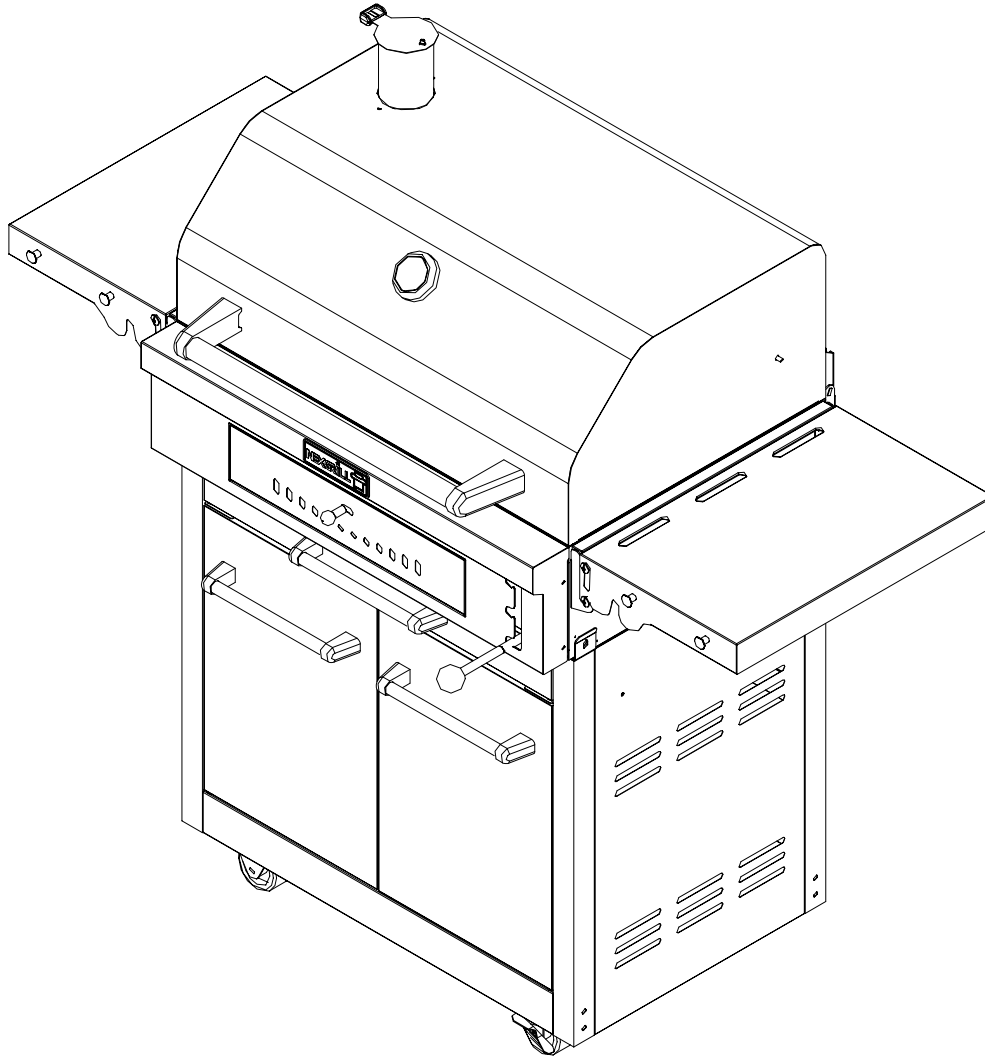

OUTDOOR CHARCOAL GRILL

MODEL #810-0018



SERIAL # _____ MFG. DATE _____ PURCHASE DATE: _____

- **This instruction manual contains important information necessary for the proper assembly and safe use of the appliance.**
- **Read and follow all warnings and instructions before assembling and using the appliance.**
- **Keep this manual for future reference.**



Questions, problems, missing parts? Before returning to your retailer, call our customer service department at UK:02392-322880, 8 a.m.-5 p.m. Monday - Friday.

19000401A0

Table of Contents

Safety Instruction	2-3	Assembly Instructions	10-21
Hardware Contents	4	Lighting instruction	22
Preparation	4	Operating and cooking instructions.	23-24
Packaging Contents	5-6	Proper care & maintenance	25
Exploded View	7	Ordering parts	25
Part List	8-9	Limited warranty	26

Safety Instruction

⚠ ATTENTION: This barbecue will become very hot while in use. Do not move it during operation. Do not use indoors.

⚠ CAUTION: Do not use spirit, petrol or comparable fluids for lighting or re-lighting!

WARNING: Keep children and pets away.

⚠ WARNING

Do not burn more than 10lbs of charcoal in this unit at one time.

Keep a fire extinguisher nearby at all times.

This grill is for outdoor use only, in well-ventilated areas.

The use of alcohol, prescription or non-prescription drugs may impair the user's ability to properly assemble and safely operate this unit.

Use caution when lifting and moving the unit to avoid back strain or back injury. Two people are recommended to lift or move the unit. Do not move the unit while it is in use.

DO NOT operate the unit near or under flammable or combustible materials such as decks, porches or carports. A minimum clearance of 36 in. (92cm) is required from all combustible materials. **DO NOT** operate the unit under overhead construction or combustible materials.

WARNING

This product is not to be used as a heater.

Operate the unit on a stable, level, non-flammable surface such as asphalt, concrete or solid ground. DO NOT operate the unit on flammable material such as carpet or a wood deck.

Use caution when assembling and operating this unit to avoid cuts and scrapes from edges.

DO NOT use this product in a manner other than its intended purpose. It is NOT intended for commercial use. It is not intended to be installed or used in or on a recreational vehicle and/or boats.

DO NOT Store this unit near gasoline or other combustible liquids or where other combustible vapors may be present.

DO NOT store or operate this product in an area accessible to children or pets. Store this unit in a dry, protected location.

DO NOT leave the unit unattended while in use.

DO NOT leave hot ashes unattended until the grill cools completely.

DO NOT move the unit while in use or while ashes are still hot. Allow the unit to cool completely before moving or storing.

NEVER use gasoline or other highly volatile fluids as a starter.

Always wait for any charcoal flames to subside before placing food on cooking grid.

Dispose of cold ashes by wrapping them in a heavy-duty aluminum foil and placing in a noncombustible container. Make sure that there are no other combustible materials in or near the container.







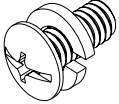

Allow the unit to cool completely before conducting any routine cleaning or maintenance.

 **Failure to comply with these instructions could result in a fire or explosion that could cause serious bodily injury, death, or property damage.**

 **Combustion by products produced when using this product contain chemicals known to the States of California to cause cancer, birth defects, or other reproductive harm.**

 **Your grill will be very hot. Never lean over the cooking area while using your grill. Do not touch cooking surfaces, grill housing, lid or any other grill parts while the grill is in operation, or until the gas grill has cooled down after use.**

Hardware Contents

Item	Description	Size	Extra hardware	Quantity
AA	1/4-in. x 15-mm Truss head screws with locking washers 	28	2	30
BB	5/32-in. x 10-mm Truss head screws with locking washers 	16	2	18
CC	1/4 -in. nuts 	5	1	6
DD	1/4- in. x 15-mm stage screws 	4	1	5
EE	5/32-in. x 10-mm Flat Head Screws 	4	1	5
FF	1/4-in. Flat washers 	25	2	27
GG	Flat washer for utensil hooks 	4	1	5
HH	Chimney lid spring 	1	0	1
II	ST4.2 x 10-mm Self-tapping screws 	4	1	5

Preparation

Before beginning assembly, make sure all parts are present. Compare parts with package contents list and diagram above. If any part is missing or damaged, do not attempt to assemble the product. Contact customer service for replacement parts.

•Tools required for assembly (not included).

- Phillips Screwdriver
- Wrench

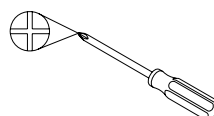



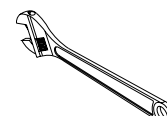

Phillips Screwdriver



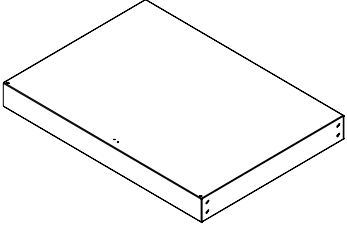

Wrench

• Note: The grill right and left sides are on your right and left as you face the front of the grill.

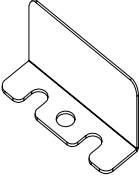
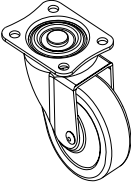
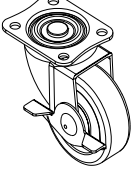
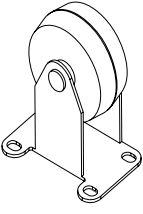
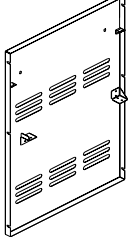
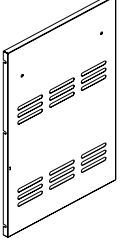
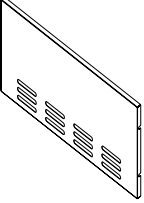
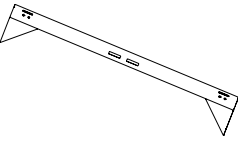
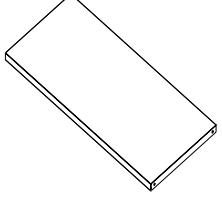
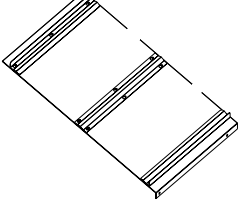
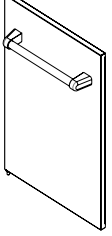
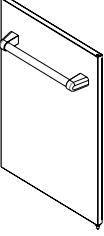
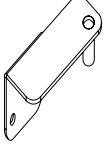
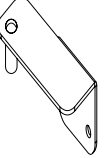
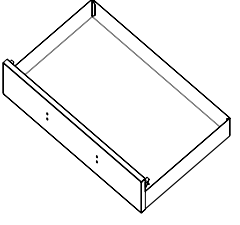
Package Contents

<p>A. Bottom panel-1 pc</p> 	<p>B. Right cart leg, front-1pc</p> 	<p>C. Right cart leg, back--1 pc</p> 	<p>D. Left cart leg, front--1 pc</p> 
<p>E. Left Cart leg, back-1 pc</p> 	<p>F. Door iron piece-1 pc</p> 	<p>G. Swivel caster-1 pc</p> 	<p>H. Swivel caster with brake-1 pc</p> 
<p>I. Stationary caster-2 pcs</p> 	<p>J. Side panel, left -1 pc</p> 	<p>K. Side panel, right -1 pc</p> 	<p>L. Back panel - 2 pcs</p> 
<p>M. Cart frame - 1 pc</p> 	<p>N. Cart central panel – 1 pc</p> 	<p>O. Cart top panel – 1 pc</p> 	<p>P. Door, left – 1 pc</p> 
<p>Q. Door, right – 1 pc</p> 	<p>R. Door hinge plate, left-1pc</p> 	<p>S. Door hinge plate, right – 1 pc</p> 	<p>T. Charcoal ash tray- 1 pc</p> 

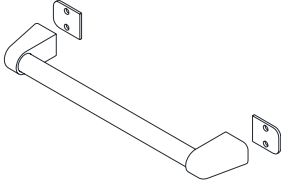
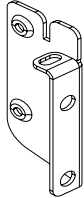
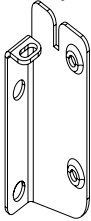
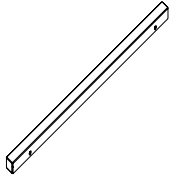
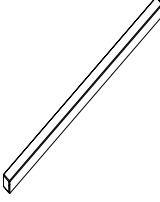
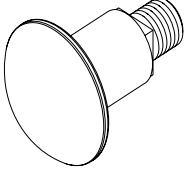
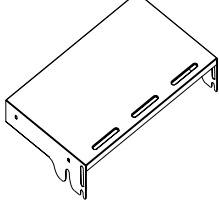
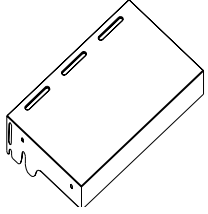
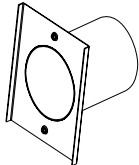
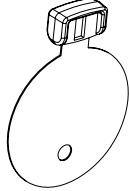
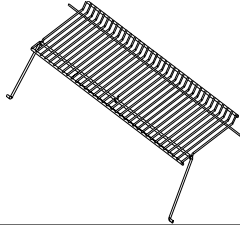
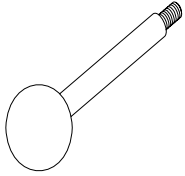
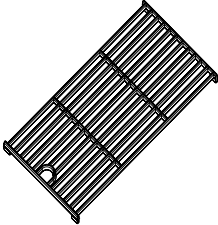
Package Contents

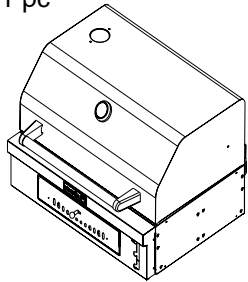
<p>U. Charcoal ash tray handle assembly- 1 pc</p> 	<p>V. Side shelf support bracket A -2pcs</p> 	<p>W. Side shelf support bracket B -2pcs</p> 	<p>X. Side shelf trim piece, left-1 pc</p> 
<p>Y. Side shelf trim piece, right-1 pc</p> 	<p>Z. Side shelf hook-4pcs</p> 	<p>AB. Side shelf, left-1 pc</p> 	<p>AC. Side shelf, right-1 pc</p> 
<p>AD. Charcoal Chimney -1 pc</p> 	<p>AE. Chimney lid -1 pc</p> 	<p>AF. Warming rack -1 pc</p> 	<p>AG. Charcoal pan control knob -1 pc</p> 
<p>AH. Cooking grid with hole - 3 pcs</p> 	<p>AI. Cooking grid lifter -1 pc</p> 	<p>AJ. Firebox assembly ---- ---1 pc</p> 	

Explode view

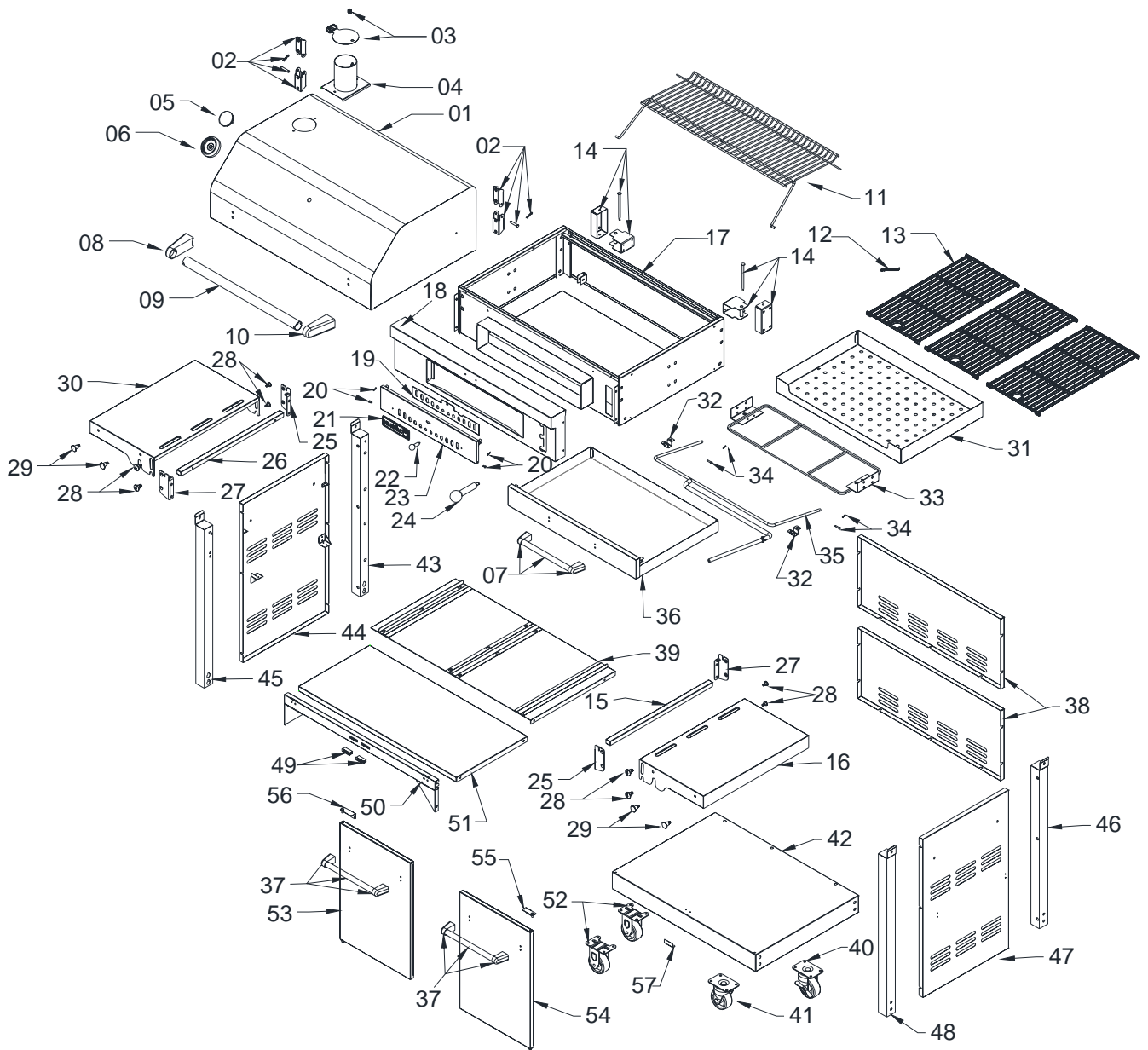

Part List

No.	Part (Description)	Warranty coverage	QTY	No.	Part (Description)	Warranty coverage	QTY
1	Main lid	1	1	27	Side shelf support bracket B	1	2
2	Main lid hinge	1	2	28	Side shelf stage screw	1	8
3	Chimney lid	1	1	29	Side shelf hook	1	4
4	Charcoal Chimney	1	1	30	Side shelf, left	1	1
5	Temperature gauge	1	1	31	Charcoal pan	1	1
6	Temperature gauge housing	1	1	32	Charcoal pan support bracket	1	2
7	Charcoal ash tray handle assembly	1	1	33	Charcoal pan support	1	2
8	Main lid handle seat, left	1	1	34	Charcoal pan control knob pin assembly	1	2
9	Main lid handle tube	1	1	35	Charcoal pan adjustment assembly	1	1
10	Main lid handle seat, right	1	1	36	Charcoal ash tray	1	1
11	Warming rack	1	1	37	Door handle assembly	1	2
12	Cooking grid lifter	1	1	38	Back panel	1	2
13	Cooking grid with hole	1	3	39	Cart top panel	1	1
14	Charcoal pan support bracket with pin	1	2	40	Swivel caster with brake	1	1
15	Side shelf trim piece, right	1	1	41	Swivel caster	1	1
16	Side shelf, right	1	1	42	Bottom panel	1	1
17	Charcoal bowl assembly	Non-replaceable	1	43	Left cart leg, back	1	1
18	Main control panel	1	1	44	Side panel, left	1	1
19	Ventilation adjustment bracket	1	1	45	Left cart leg, front	1	1
20	Ventilation door screw pin assembly	1	2	46	Right cart leg, back	1	1
21	Logo	1	1	47	Side panel, right	1	1
22	Ventilation door control knob	1	1	48	Right cart leg, front	1	1
23	Ventilation panel	1	1	49	Door magnet	1	2
24	Charcoal pan control knob	1	1	50	Cart frame	1	1
25	Side shelf support bracket A	1	2	51	Cart central panel	1	1
26	Side shelf trim piece, left	1	1	52	Stationary caster	1	2

Part List

No.	Part (Description)	Warranty coverage	QTY	No.	Part (Description)	Warranty coverage	QTY
53	Door, left	1	1	57	Door iron piece	1	1
54	Door, right	1	1		KD assembly hardware pack	1	1
55	Door hinge plate, right	1	1		Manual	1	1
56	Door hinge plate, left	1	1		Grill cover	1	1

Assembly Instructions

Tool Required: Philips Screwdriver

1. Caster Assembly

- a). Mount the casters onto the bottom panel (A) using sixteen 1/4-in. x 15-mm truss head screws with locking washers (AA) and sixteen 1/4-in flat washers (FF).
- b). The swivel caster with brake (H) should be positioned under the left rear of the cart bottom and the swivel caster (G) should be positioned under left front as shown in Fig. 1.
- d). The two stationary casters (I) should be positioned under the right side.
- e). Turn over the bottom panel for assembling casters.

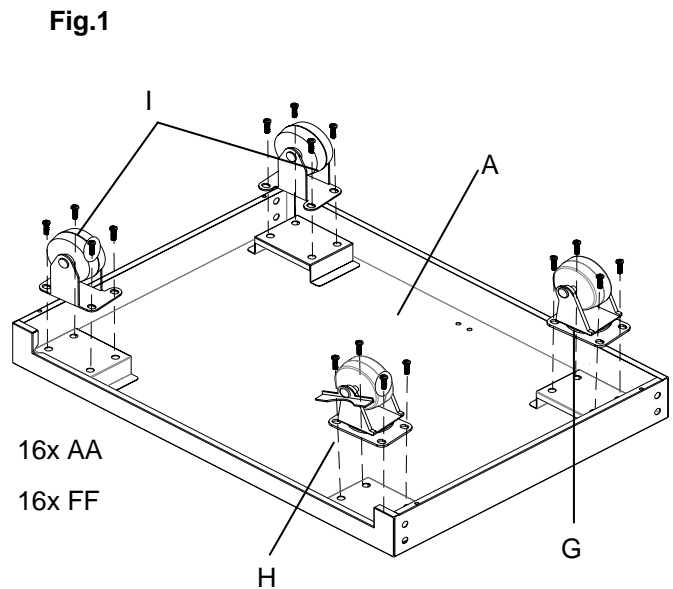

Step 2. L shape bracket assembly

- a). Loosen, but do not remove the screws that are pre-assembled on the bottom panel (A), align the holes on the bottom panel (A), then attach the L shape bracket (F) onto the bottom panel (A) by aligning the holes.
- b). Tighten the two screws that were loosened above. As shown in Fig. 2.

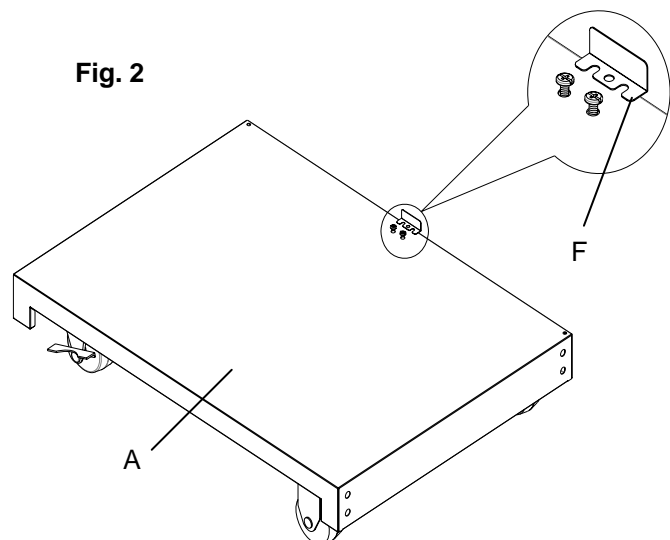

Step 3. Cart leg assembly

Note: The back legs are the two that have 4 side screws on the inside of each leg and the front legs have two screws the face to the back of the grill for attaching the side panels.

- a). Loosen, but do not remove the 4 screws that are pre-assembled on the bottom panel (A), align the holes on the left cart leg, front (D) and left cart leg, back (E), then place the cart legs onto the bottom panel by aligning the screws that were loosened in the bottom panel (A) as shown in Fig. 3.
- b). Tighten the screws that were loosened above.

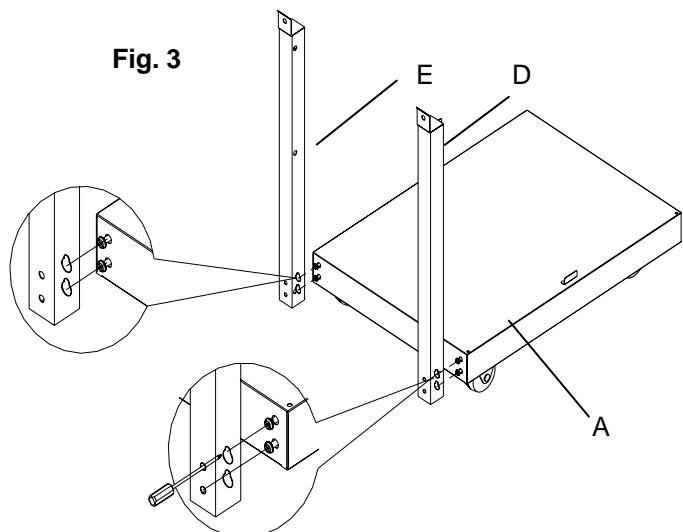

Assembly Instructions

c). Loosen, but do not remove the 4 screws that are pre-assembled on the bottom panel (A), align the holes on the right cart leg, front (B) and right cart leg, back (C), then place the cart legs onto bottom panel (A) by aligning the screws that were loosened on the bottom panel as shown in Fig. 4.

d). Tighten the screws that were loosened above.

Fig. 4

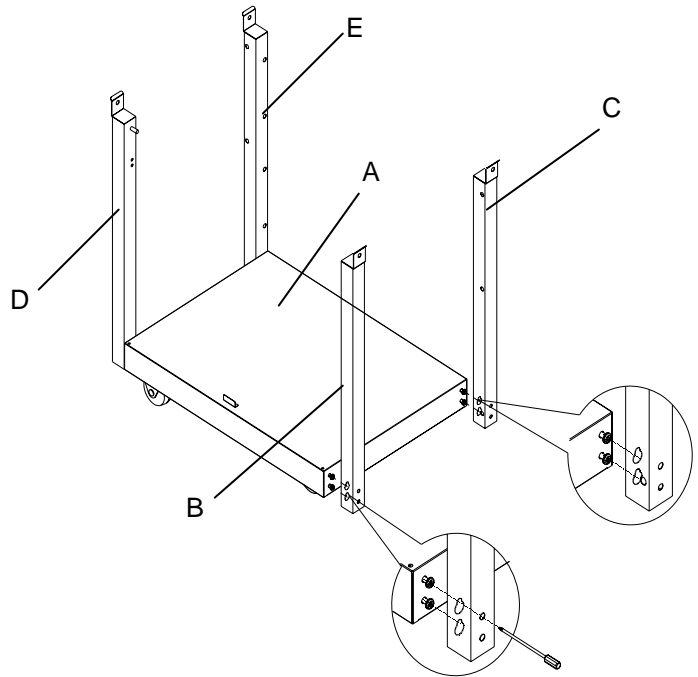

Step 4: Side panel assembly

a). Loosen the 12 screws which are pre-assembled on the left and right side legs, toward to inside (6 screws on each side).

b). Attach the side panel, left (J) by aligning the holes on the side panel with the loosened screws on the inner side of cart leg. Tighten the six screws that were loosened to secure the panel as shown in Fig. 5.

c). Repeat step a) and b) for the side panel, right (K) assembly.

Fig. 5

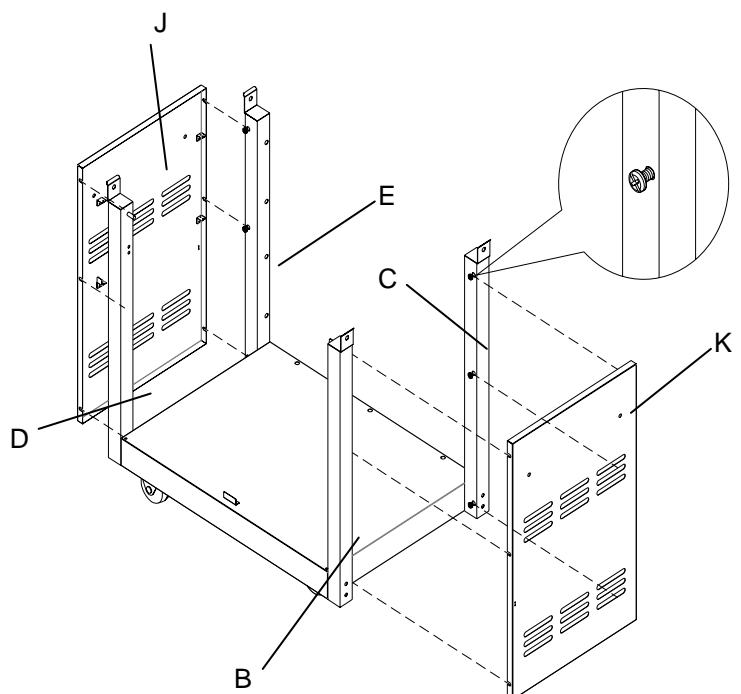

Assembly Instructions

Step 5. Back panel assembly

Fig. 6

- a). Loosen, but do not remove 7 screws which are pre-assembled on the bottom cart legs and bottom panel (4 screws on the left and right back cart legs and 3 screws on the bottom panel).
- b). Attached back panel (L) by aligning the holes on the back panel with screws in the leg, then tighten the 7 screws that were loosened in step a). As shown in Fig. 6.

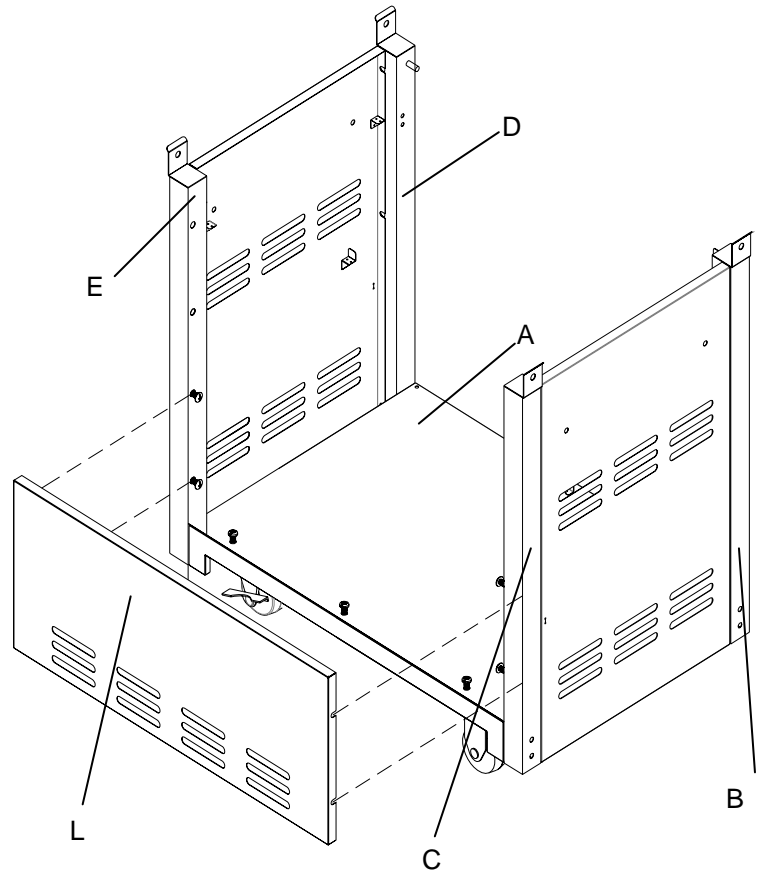
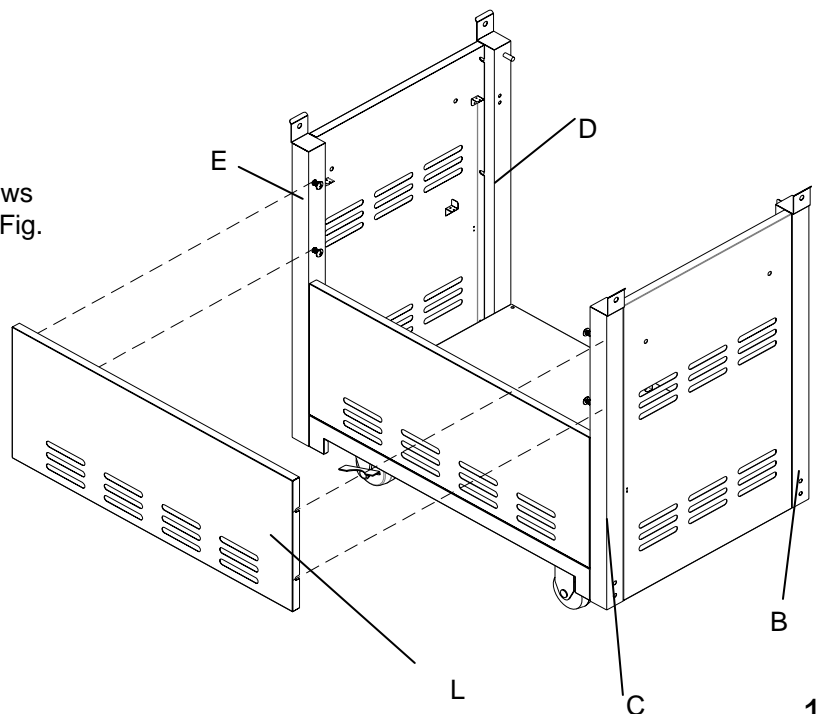

Fig. 7

- c). Loosen, but do not remove the 4 screws which are pre-assembled on the upper cart legs as shown in Fig. 7.
- d). Attach the other piece of back panel (L) by aligning the holes in the back panel with screws in the leg, then tighten the four screws that were loosened in step c). As shown in Fig. 7.



Step 6. Cart frame assembly

- a). Loosen, but do not remove the four screws which are pre-assembly on the left and right cart leg, front (D/B). Attach the cart frame (M) to the left cart leg, front (D) and right cart leg, front (B). then tighten the screws which loosened above. As shown in Fig. 8.
- b). Attach the left and right triangle brackets of cart frame (M) by using two 5/32-in. x 10-mm truss head screws with locking washers (BB) . As shown in Fig. 8.

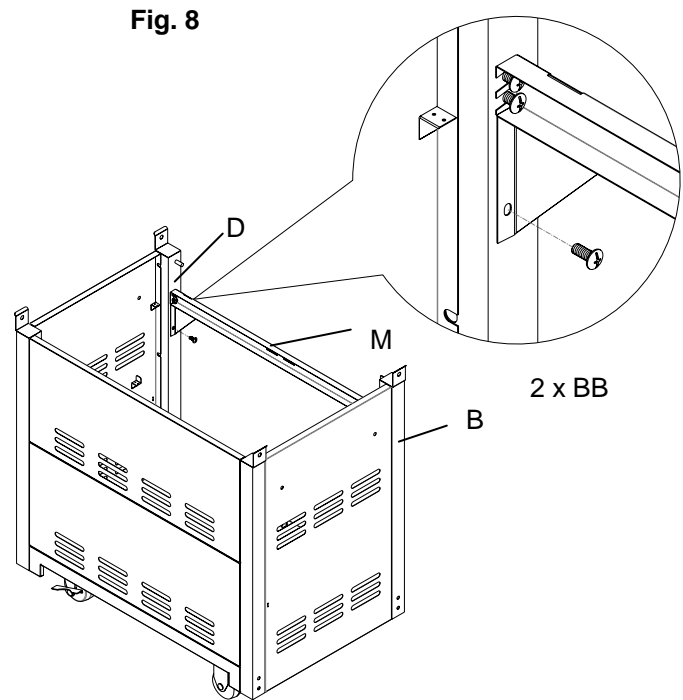

Step 7. Cart central panel assembly

Place cart central panel (N) upon the four lower brackets on the left and right side panels as shown in Fig. 9.

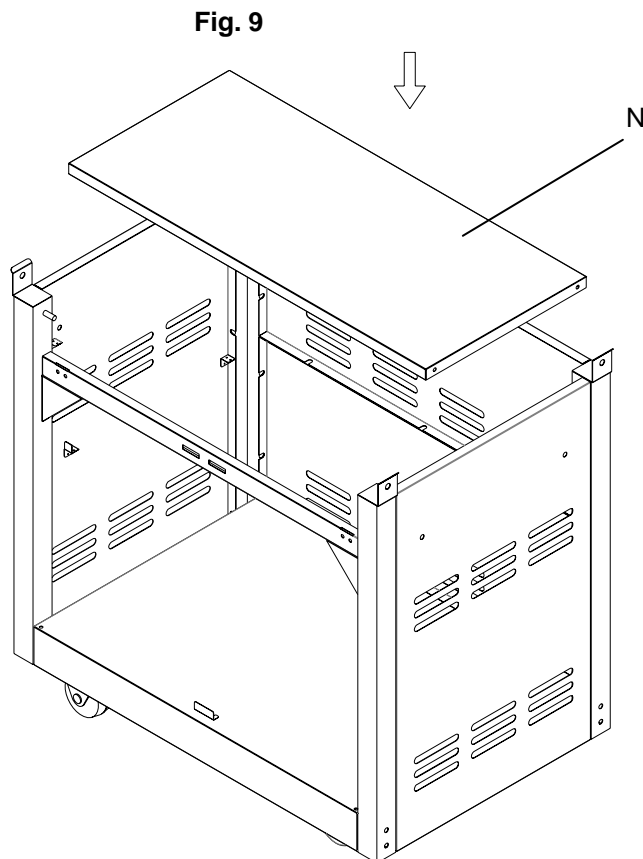

Step 8. Door assembly

- a). Insert the bottom hinge of door, left (P) into the hole of bottom panel (A) and insert the door hinge plate, left (R) into the hole on the top of door, left top (P). As shown in Fig.10.

Fig.10

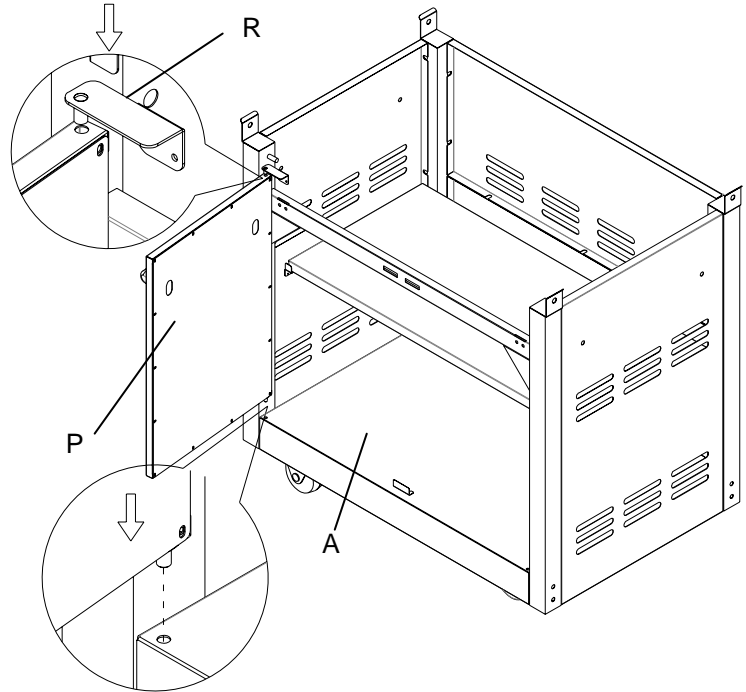

- b). Attach the door hinge plate, left (R) to cart frame (M) by using two 5/32-in. x 10- mm flat head screws (EE) as shown in Fig.11.

- c). Repeat step a) and b) for the right door (Q) and door hinge plate, right (S).

Fig. 11

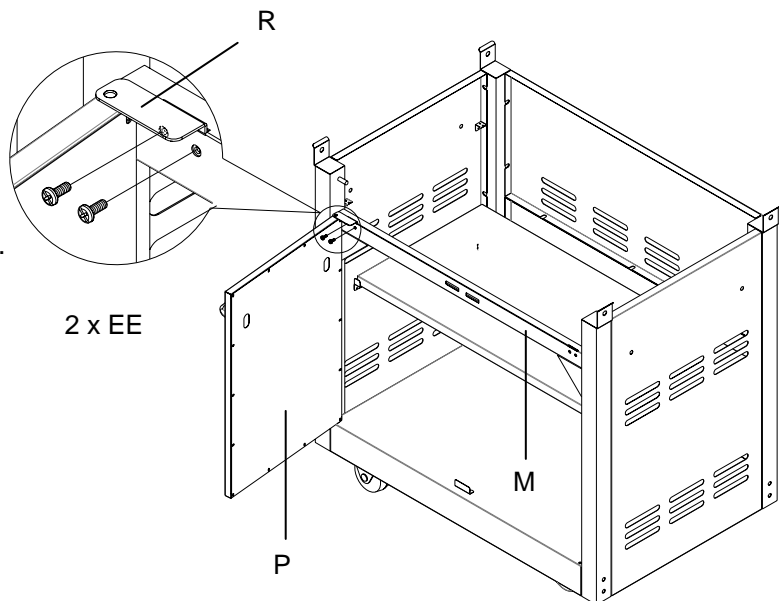

Assembly Instructions

Step 9. Cart top panel assembly

- a). Place the cart top panel (O) upon upper four brackets of the left and right side panels. As shown in Fig. 12.

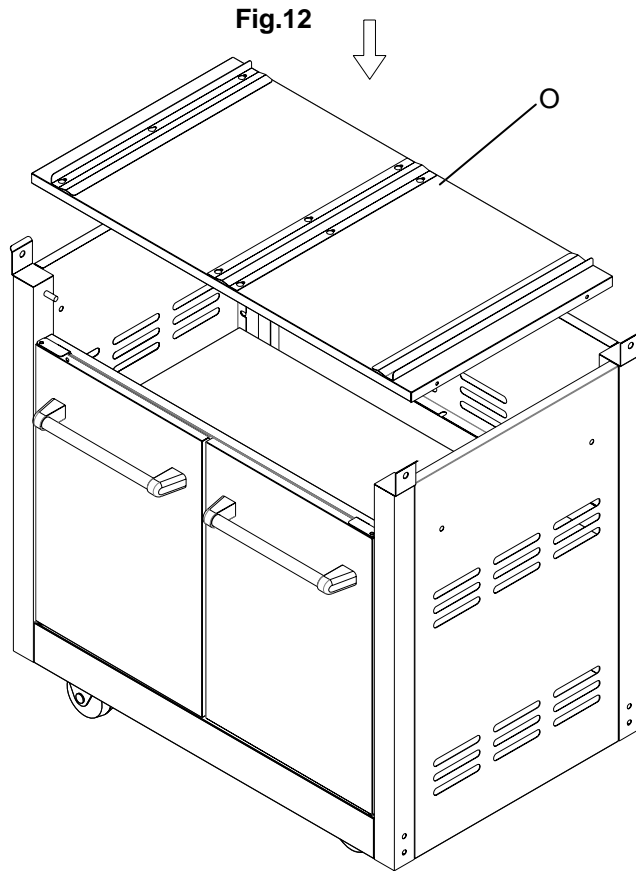

- b). Attached the cart top panel (O) to the side panel, left (J) by using and two 5/32-in. x10-mm truss head screws with locking washers (BB) as shown in Fig. 13.

- c). Repeat step b) to attach the side panel, right (K).

Note: The screws should be screwed from outside of left and right side panels to inside.

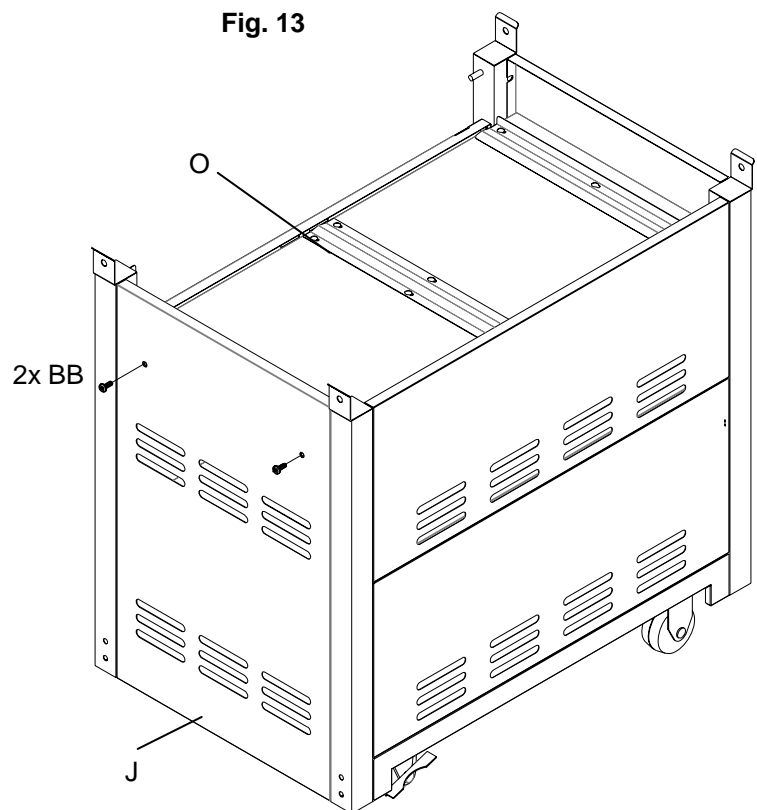

Assembly Instructions

Step 10. Firebox Assembly

- a). Remove the firebox assembly (AJ) from the carton and carefully place onto the grill cart, at the same time keeping the top door hinge in place as shown in Fig. 14.

⚠ CAUTION The firebox assembly is heavy and will require two or more people to lift and position onto grill cart. Failure to do so may result in injury.

Note: Take care when moving the firebox assembly as the bottom flanges can be bent, which would misalign the holes.

- b). Then secure the firebox assembly (AJ) by using four 1/4-in. x 15-mm truss head screws with locking washers (AA) as shown in Fig. 14.

Note: Two screws for each side of cart as shown in Fig. 14.

Fig. 14

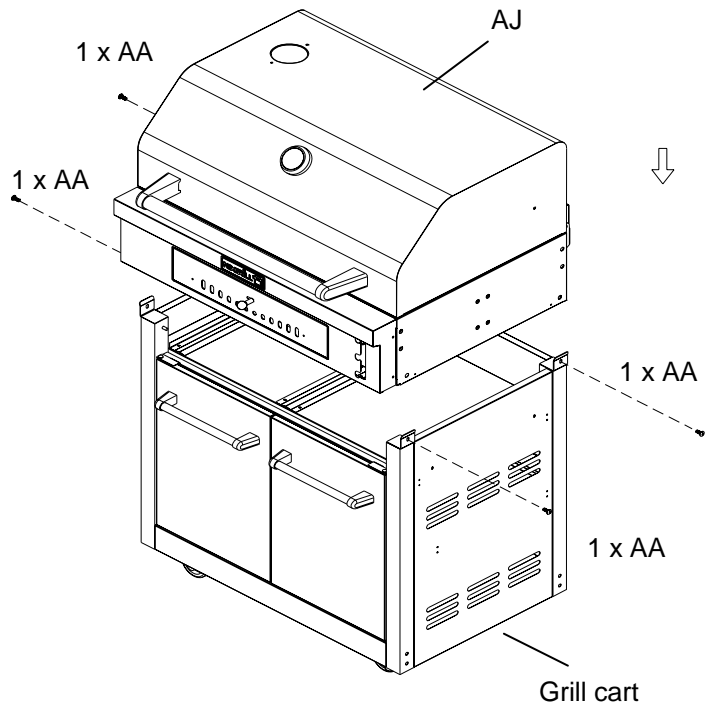
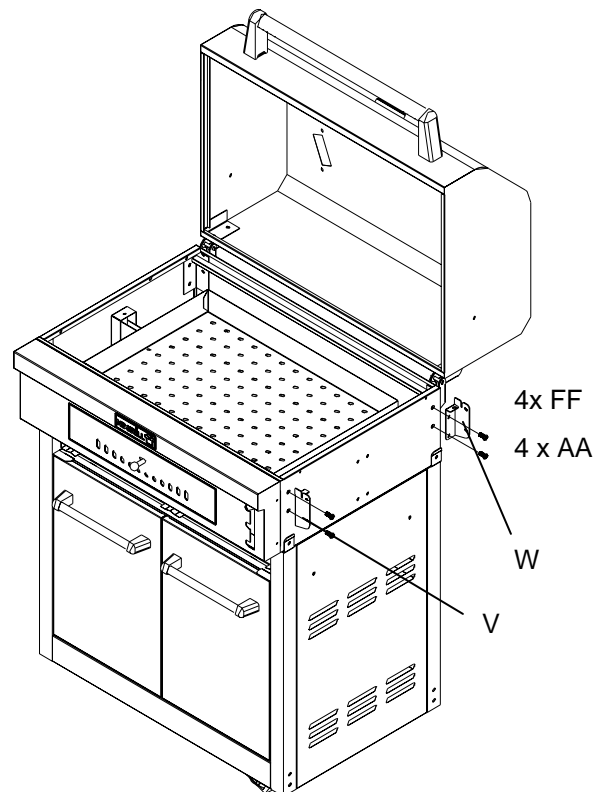

Fig. 15

Step 11. Side shelf assembly

- a). Attach the side shelf support bracket A and B (V/W) onto the firebox by using four 1/4-in. x 15-mm truss head screws with locking washers (AA) and four 1/4-in flat washers (FF) as shown in Fig 15.



Assembly Instructions

- b). Attach the side shelf trim piece, right (Y) into the side shelf bracket A and B (V/W) by using four 5/32-in. x 10-mm truss head screws with locking washers (BB) as shown in Fig. 16.

Note: Two screws should be screwed at front and back of trim piece from inside of the firebox to outside, and two screws should be screwed front and back from the bottom of side shelf trim piece to the top.

Fig. 16

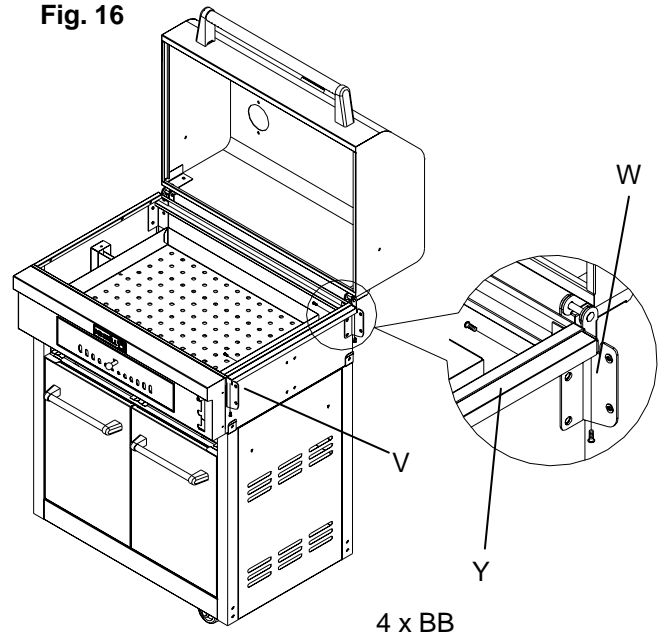
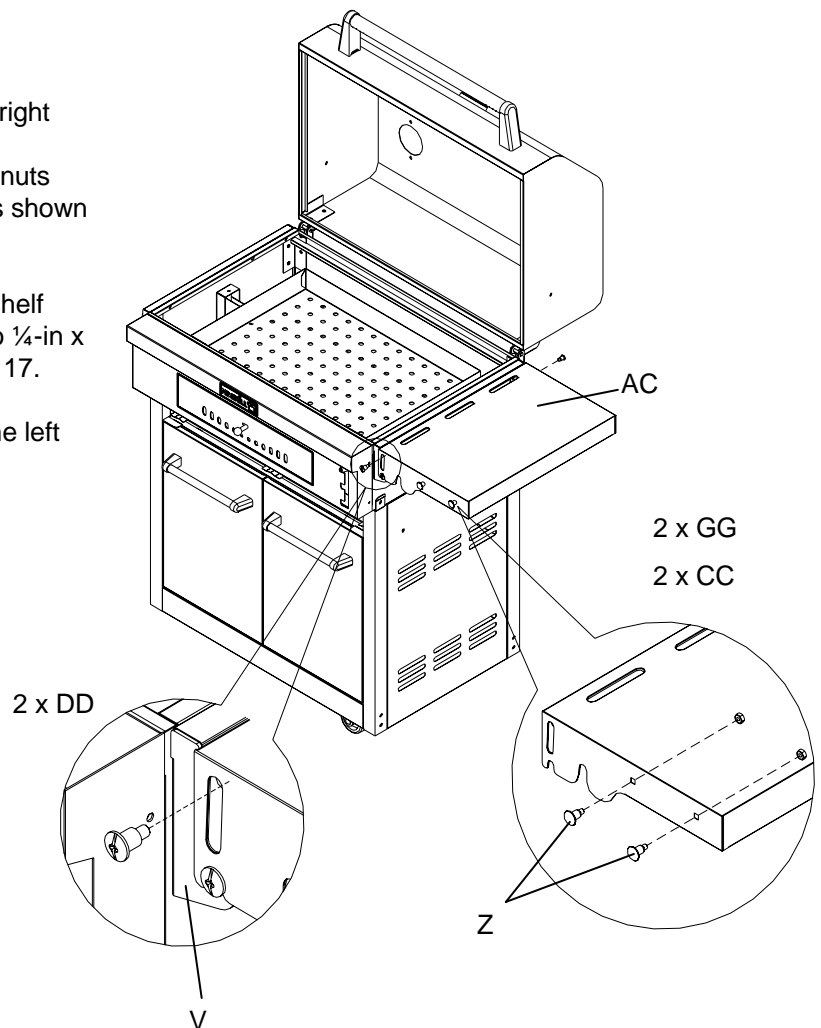

Fig. 17

- c). Attach the two side shelf hooks (Z) into the right side shelf by using two 1/4-in nuts (CC) and two side shelf hook flat washers (GG). (The nuts should be screwed at inside of side shelf. As shown in Fig. 17.)
- d). Attach the right side shelf (AC) to the side shelf support bracket A and B (V/W) by using two 1/4-in x 15 mm stage screws (DD) as shown in Fig. 17.
- e). Repeat step a), b), c) and d) to assemble the left side shelf (AB).



Assembly Instructions

Step 12. Chimney Assembly

- a). Insert the Charcoal Chimney (AD) from lid inner to outside, the chimney seat is closed to the lid inner, then attach it onto the hood by using two 5/32-in. x 10-mm truss head screws with locking washers (BB) as shown in Fig. 18.

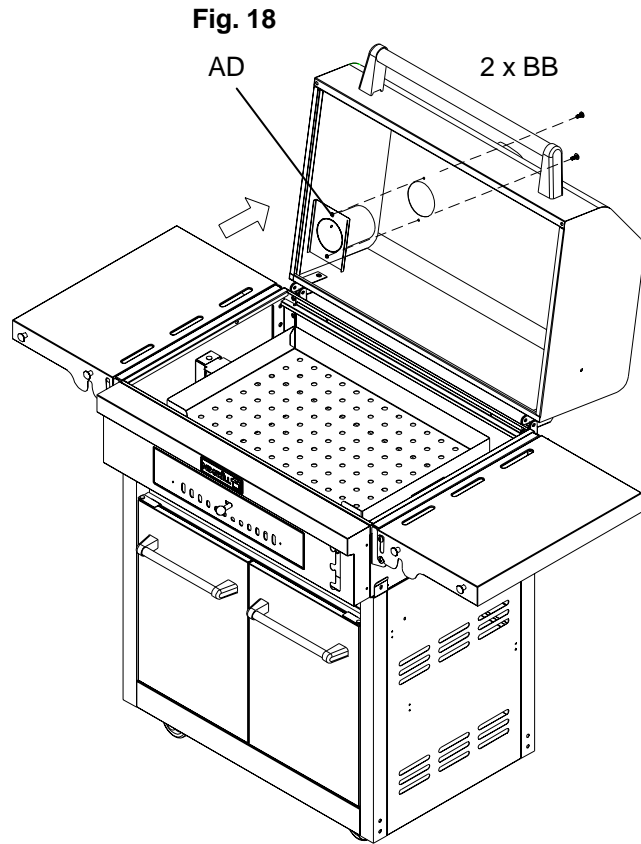

- b). Attach the chimney lid (AE) onto the Charcoal Chimney (AD) by using one chimney lid spring (HH), one 1/4-in flat washer (FF) and one 1/4-in nut (CC). As shown in Fig. 19.

Note: 1/4-in flat washer (FF) goes between 1/4-in nut (CC) and Chimney lid spring (HH).

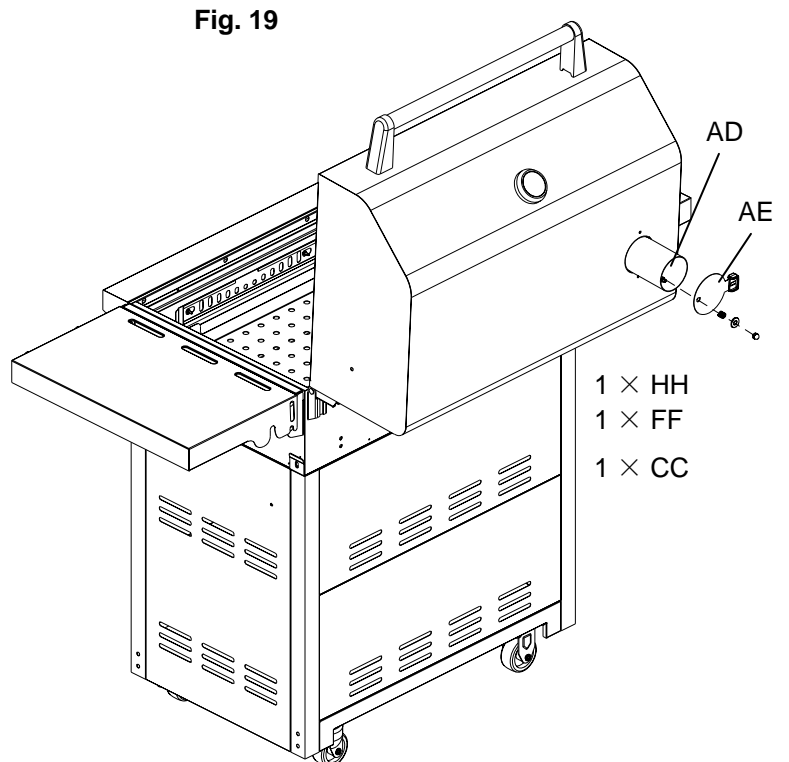

Assembly Instructions

Step 13. Warming rack assembly

Insert 4 legs of the warming rack (AF) into the firebox and lid's hole as shown Fig. 20.

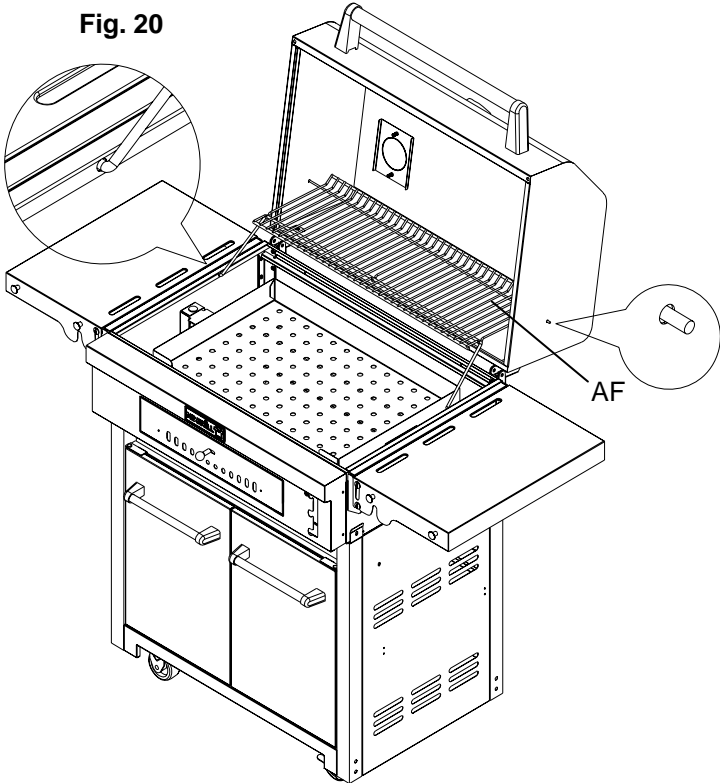

Step 14. Charcoal pan handle Assembly

Place the charcoal pan control knob (AG) into charcoal pan control rod which located behind of control panel and tighten the charcoal pan control knob (AG) in clockwise to secure it as show in Fig.21.

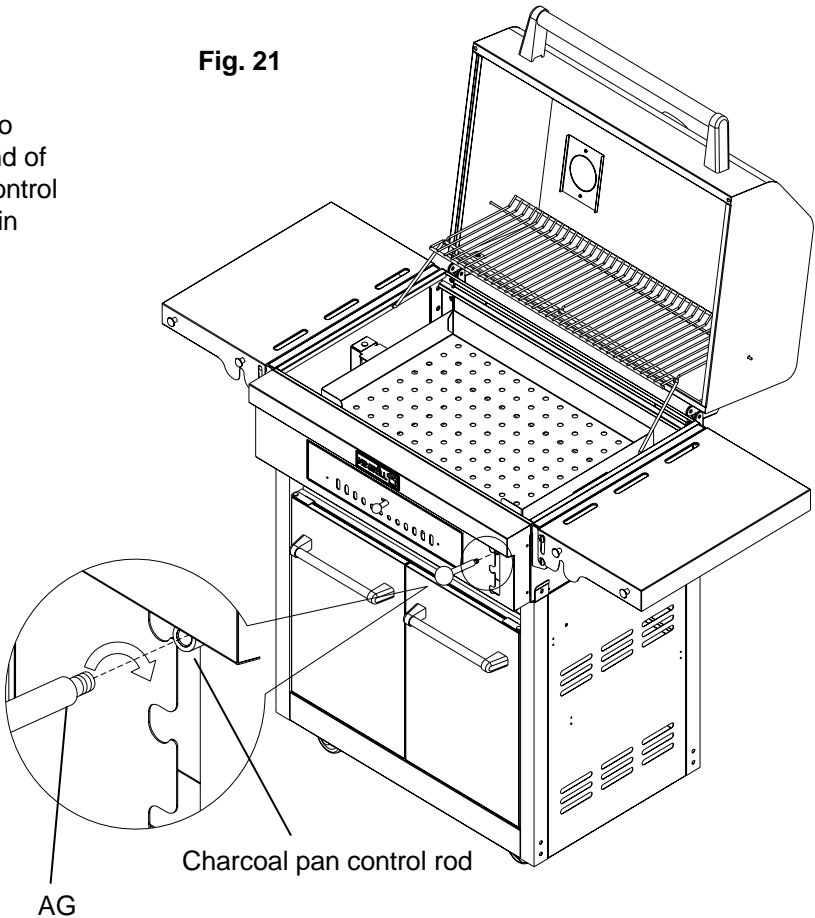

Step 15. Cooking grid and cooking grid lifter installation

a). Place the cooking grid (AH) as shown in Fig. 22.

Fig. 22

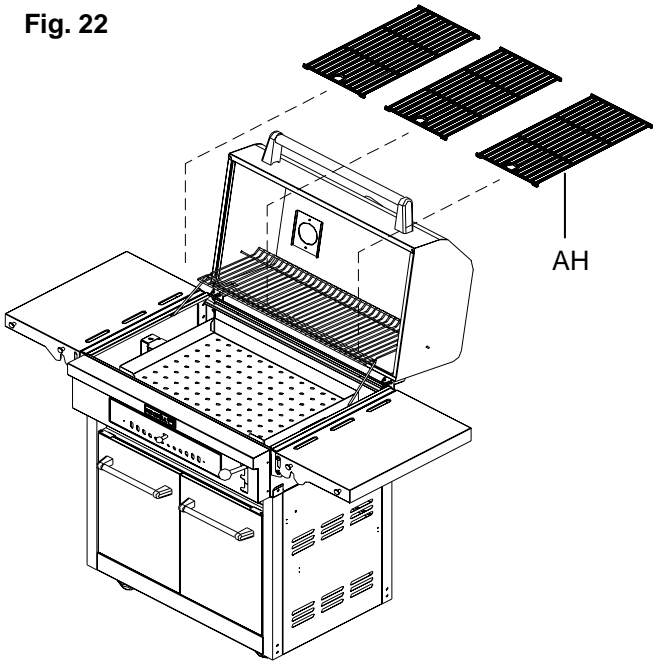

b). Place the cooking grid lifter (AI) onto the cooking grid as shown in Fig. 23.

Fig. 23

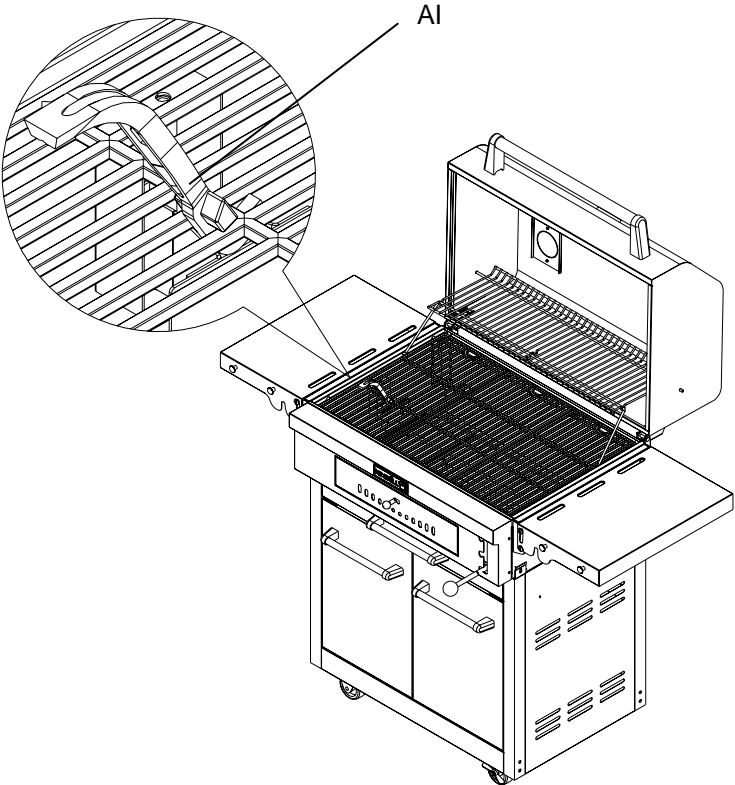

Step 16. Charcoal ash tray assembly

- a). Insert the charcoal ash tray handle tube into the charcoal ash tray handle seat as shown in Fig. 24.
- b). Attach the charcoal ash tray handle assembly (U) with two heat insulating spacers onto the charcoal ash tray by aligning holes and using four ST4.2 x 10-mm Self-tapping screws (II). As shown in Fig. 24.

Fig. 24

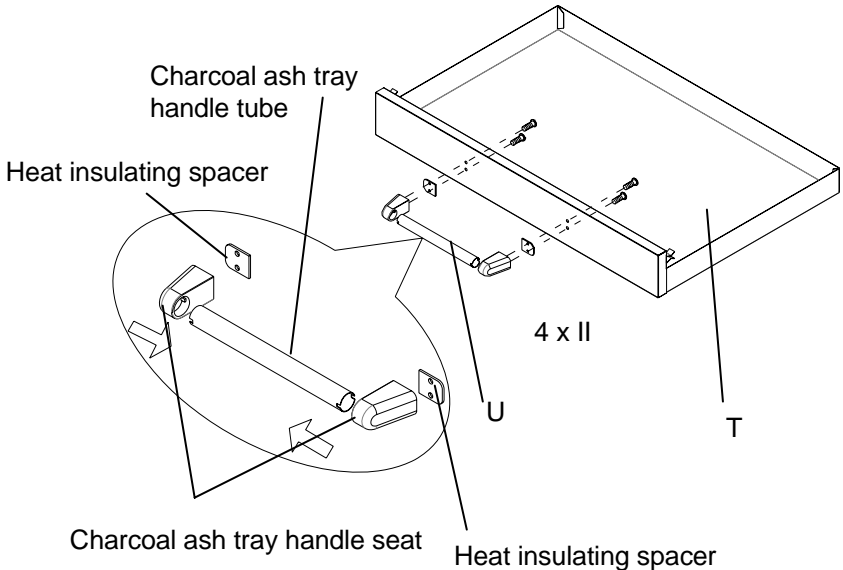
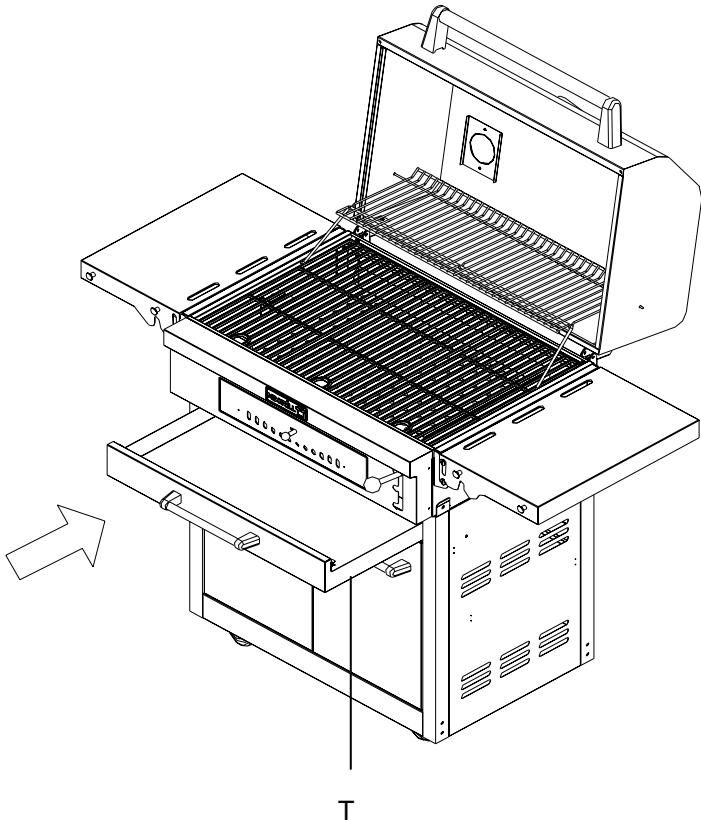

Fig. 25

- c). Slide the charcoal ash tray (T) into the grill cart as shown in Fig. 25.



⚠ READ ALL SAFTY WARNINGS AND INSTRUCTIONS CAREFULLY BEFORE OPERATING YOUR GRILL.

Charcoal Lighting instructions:

1. Open grill lid.
2. Lift the charcoal tray handle to adjust charcoal pan to middle height position.
3. Pour regular charcoal briquettes, not exceeding 10 pounds into charcoal pan and arrange into a pile. Make sure charcoal does not go above the Charcoal Grid.
4. Light charcoal briquettes.
5. Adjust the charcoal pan handle to low position. Wait for charcoal flames to subside.
6. Once briquettes are glowing, use the charcoal pan handle to adjust charcoal pan to desired cooking position.

ADJUSTING TEMPERATURE

To control the cooking temperature, shift the ventilation knob at the front of the grill to open and close the ventilation. To increase temperature, open the ventilation. To dampen temperature, close the ventilation.

NOTE: The temperature should not exceed 500° F, The temperature can be checked using the temperature gauge on the grill lid.



WARNING

Always wear oven mitts/glovers when adjusting cooking levels to protect your hands from burn.



WARNING

Do not use grill without charcoal ash drawer in place. DO NOT attempt to remove charcoal ash tray while drawer contains hot coals.

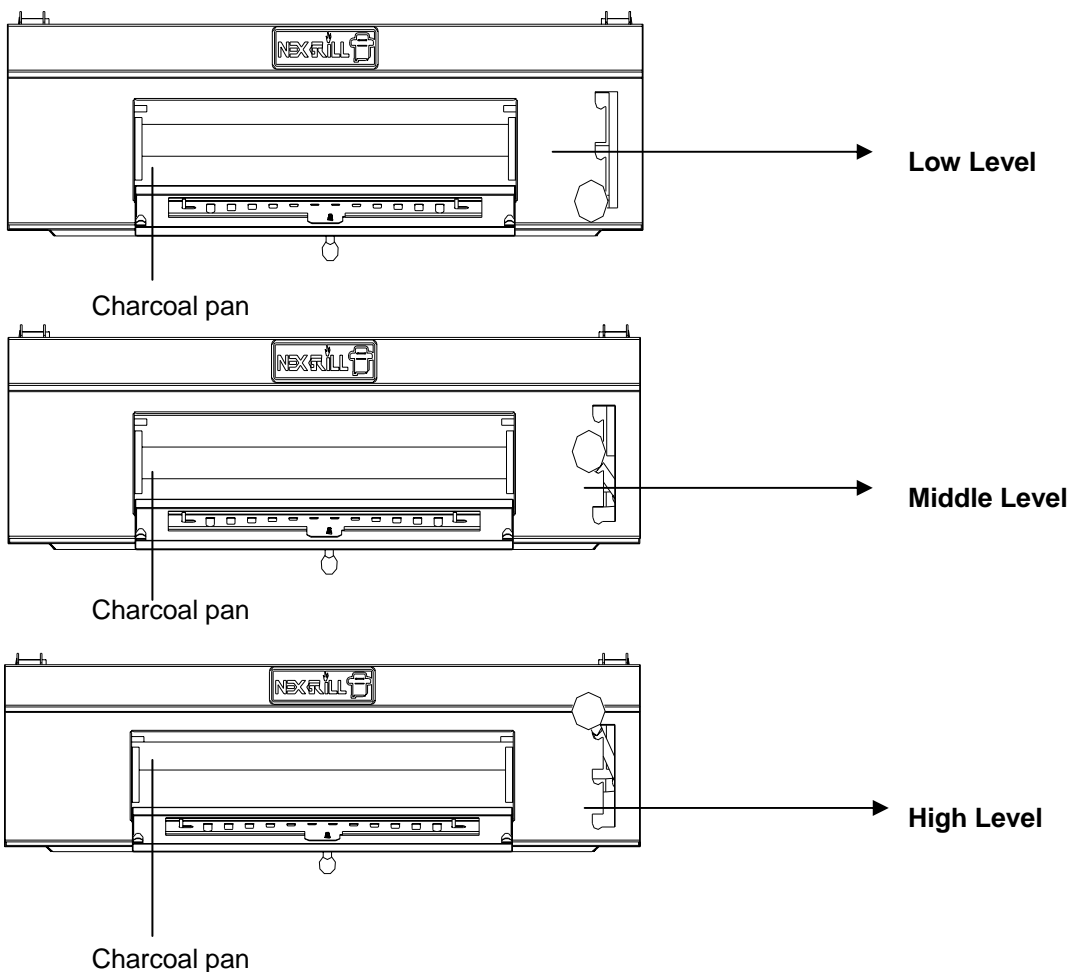

Operating and Cooking Instructions

Operating Tips

Charcoal Grid Lifter

When the grill is completely cooled, use a glove to remove Charcoal Grid to add charcoal to the Charcoal Pan. Do not leave the grid lifter inside the grill as it will get too hot to handle safely.



Charcoal grid lifter

Charcoal Tray Handle Operation

By lifting the charcoal pan handle, the charcoal pan can be raised or lowered to adjust the cooking heat at any time during cooking. Raising the pan increases direct heat. Lowering the pan reduces direct heat. Raise the tray after unit has cooled down completely to make it easier to brush left over ash into the ash tray. Do not raise the tray higher than halfway when fully loaded with fresh charcoal.

Ventilation Door Control Knob Operation

To open the ventilation door, pull the ventilation knob.

To adjust ventilation, move the ventilation knob to the right or left.

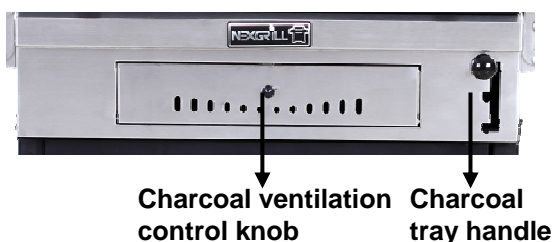

⚠ READ ALL SAFTY WARNINGS AND INSTRUCTIONS CAREFULLY BEFORE OPERATING YOUR GRILL.

Grilling/Searing

1. Follow the instructions below carefully to build a fire. You may use charcoal and /or wood as fuel in the Professional Grill (See "Adding Charcoal/Wood During Cooking" section of this manual).

⚠ WARNING:

Never use charcoal that has been pre-treated with lighter fluid. Use only a high grade plain charcoal or charcoal wood mixture.

If using a Charcoal Chimney Starter, follow all manufacturer's warnings and instructions regarding the use of their product. Start with 8-10 pounds of charcoal. This should be enough charcoal to cook with, once the curing process has been completed. Pull the front air ventilator to the left halfway. When charcoal is burning strong, carefully place hot coals in center of charcoal pan.

⚠ WARNING:

DO NOT use grill without charcoal ash tray in place. DO NOT attempt to remove charcoal ash tray while tray contains hot coals.

NOTE: To extend the life of your grill, make sure that hot coals and wood do not touch the walls of grill.

IF USING CHARCOAL CHIMNEY STARTER, PROCEED TO STEP 4

If you choose to use charcoal lighting fluid, ONLY use charcoal lighting fluid approved for lighting charcoal. Do not use gasoline, kerosene, alcohol or other flammable material for lighting charcoal. Follow all manufacturer's warnings and instructions regarding the use of their product. Start with 8-10 pounds of charcoal. Placed the charcoal in center of charcoal pan.

2. Saturate charcoal with lighting fluid. With open wait 2 to 3 minutes to allow lighting fluid to soak into charcoal. Store charcoal lighting fluid safely away from the grill.

3. With grill lid open, stand back and carefully light charcoal and allow to burn covered with a lighting ash (approximately 20 minutes).

Operating and Cooking Instructions



WARNING:

Charcoal lighting fluid must be allowed to completely burn off prior to closing grill lid (approximately 20 minutes). Failure to do this could trap fumes from charcoal lighting fluid in grill and may result in a flash-fire or explosion when lid is opened.

4. Place cooking grill on grill support lips. Use charcoal pan to desired cooking level.



WARNING:

Always wear oven mitts/gloves when adjusting cooking levels to protect your hands from burns.

5. Place food on cooking grill and close grill lid. By closing the front air ventilation more, the burning intensity is slowed. Always use a meat thermometer to ensure food is fully cooked before removing from grill.

6. Allow grill to cool completely, then follow instructions in the "After-Use Safety" and "Proper Care & Maintenance" section of this manual.

Regulating Heat

To increase heat, more charcoal may be needed or an adjustment to charcoal height. Follow instructions in "Adding Charcoal During Cooking" section of this manual.

To maintain the temperature, more charcoal may need to be added or an adjustment may be necessary during the cooking cycle to charcoal height.

Add Charcoal/Wood During Cooking

Additional charcoal and/or wood may be required to maintain or increase cooking temperature.

1. Stand back and carefully open grill lid. Use caution since flames can flare-up when fresh air suddenly comes in contact with fire.



WARNING:

Wear protective gloves or oven mitts when adjusting cooking grill or charcoal pan height.

2. Wearing oven mitts/gloves, use charcoal pan handle to adjust the charcoal pan to the low position. Remove the food from cooking grid, then remove the cooking grid.

3. Stand back a safe distance and use long cooking tongs to lightly brush aside ashes on hot coals. Use cooking tongs to add charcoal and/or wood to charcoal pan, being careful not to stir-up ashes and sparks. If necessary, use your charcoal chimney starter to light additional charcoal and/or wood and add to existing fire.



WARNING:

Never add charcoal lighting fluid to hot or even warm coals as flashback may occur causing severe burns.

4. When the charcoal is burning strong again, wear oven mitts/gloves and carefully return charcoal pan to desired cooking level.

5. Close the grill lid and door. Allow food to continue cooking.

After-Use Safety



WARNING:

- ◆ Always allow grill and all components to cool completely before handling.
- ◆ Never leave coals and ashes in grill unattended. Make sure coals and ashes are completely extinguished before removing.
- ◆ Before grill can be left unattended, remaining coals and ashes must be removed from grill. Use caution to protect yourself and property. Place remaining coals and ashes in a non-combustible metal container and completely saturate with water. Allow coals and water to remain in metal container 24 hours prior to disposing.
- ◆ Extinguished coals and ashes should be placed a safe distance from all structures and combustible materials.
- ◆ With a garden hose, completely wet surface beneath and around the grill to extinguish any ashes, coals or embers which may have fallen during the cooking or cleaning process.
- ◆ Cover and store grill in a protected area away from children and pets.

Proper Care & Maintenance

- ◆ To protect your grill from excessive rust, the unit must be properly cleaned and covered at all times when not in use.
- ◆ Wash cooking grill and charcoal grate with hot, soapy water, rinse well and dry.
- ◆ Clean inside and outside of grill by wiping off with a damp cloth. Apply a light coat of vegetable oil or vegetable oil spray to the interior surface to prevent rusting. Do not coat charcoal tray or charcoal ash tray.
- ◆ If rust appears on the exterior surface of your grill, clean and buff the affected area with steel wool or fine frit emery cloth, Touch-up with a good quality high-temperature resistant paint.
- ◆ Never apply paint to the interior surface. Rust spots on the interior surface can be buffed, cleaned, then lightly coated with vegetable oil or vegetable oil spray to minimize rusting.

Ordering Parts

HOW TO ORDER REPLACEMENT PARTS

To make sure you obtain the correct replacement part (s) for your gas grill, please refer to the parts list on pages **8-9**. The following information is required to assure getting the correct part. Please note the shipping cost for the delivery of any replacement parts will be at your cost.

- Gas grills model number (see data sticker on grill).
- Part number of replacement part needed.
- Description of replacement part needed.
- Quantity of parts needed.

To obtain replacement parts, contact **our customer service** hotline **UK: 02392 -322880**

IMPORTANT

Use only factory authorized parts. The use of any part that is not factory authorized can be dangerous. This will also void your warranty.

Keep this assembly and operating instruction manual for convenient referral, and for replacement parts ordering.

Limited Warranty

LIMITED WARRANTY (Model # 810-0018)

The manufacturer warrants to the original consumer-purchaser only that this product (*Model #810-0018*) shall be free from defects in workmanship and materials after correct assembly and under normal and reasonable home use for the periods indicated below beginning on the date of purchase. The manufacturer reserves the right to require photographic evidence of damage, or that defective parts be returned, postage and/or freight pre-paid by the consumer, for review and examination.

•**ALL PARTS:** 1 year *LIMITED* warranty (Includes, but not limited to frame, housing, cart, control panel) **Does not cover chipping, scratching, cracking surface corrosion, scratches or rust.*

Upon consumer supplying proof of purchase as provided herein, Manufacturer will repair or replace the parts which are proven defective during the applicable warranty period. Parts required to complete such repair or replacement shall be free of charge to you except for shipping costs, as long as the purchaser is within the warranty period from the original date of purchase. The original consumer-purchaser will be responsible for all shipping charges of parts replaced under the terms of this limited warranty. This limited warranty is applicable in the United States and Canada only, is only available to the original owner of the product and is *not transferable*. Manufacturer requires reasonable proof of your date of purchase. Therefore, you should retain your sales receipt and/or invoice. If the unit was received as a gift, please ask the gift-giver to send in the receipt on your behalf, to the below address. Defective or missing parts subject to this limited warranty will not be replaced without registration or proof of purchase. This limited warranty applies to the functionality of the product **ONLY** and does not cover cosmetic issues such as scratches, dents, corruptions or discoloring by heat, abrasive and chemical cleaners or any tools used in the assembly or installation of the appliance, surface rust, or the discoloration of stainless steel surfaces. Surface rust, corrosion, or powder paint chipping on metal parts that does not affect the structural integrity of the product is not considered a defect in workmanship or material and is not covered by this warranty. This limited warranty will not reimburse you for the cost of any inconvenience, food, personal injury or property damage. If an original replacement part is not available, a comparable replacement part will be sent. You will be responsible for all shipping charges of parts replaced under the terms of this limited warranty.

MANUFACTURER WILL NOT PAY FOR:

- Service calls to your home.
- Repairs when your product is used for other than normal, single-family household or residential use.
- Damage resulting from accident, alteration, misuse, lack of maintenance/cleaning, abuse, fire, flood, acts of God, improper installation, and installation not in accordance with electrical or plumbing codes or misuse of product..
- Any food loss due to product failures.
- Replacement parts or repair labor costs for units operated outside the United States or Canada.
- Pickup and delivery of your product.
- Postage fees or photo processing fees for photos sent in as documentation.
- Repairs to parts or systems resulting from unauthorized modifications made to the product.
- The removal and/or reinstallation of your product.
- Shipping cost, standard or expedited, for warranty/non warranty and replacement parts.

DISCLAIMER OF IMPLIED WARRANTIES: LIMITATION OF REMEDIES

Repair or replacement of defective parts is your exclusive remedy under the terms of this limited warranty. Manufacturer will not be responsible for any consequential or incidental damages arising from the breach of either this limited warranty or any applicable implied warranty, or for failure or damage resulting from acts of God, improper care and maintenance, grease fire, accident, alteration, replacement of parts by anyone other than manufacturer, misuse, transportation, commercial use, abuse, hostile environments (inclement weather, acts of nature, animal tampering), improper installation or installation not in accordance with local codes or printed manufacturer instructions.

THIS LIMITED WARRANTY IS THE SOLE EXPRESS WARRANTY GIVEN BY THE MANUFACTURER. NO PRODUCT PERFORMANCE SPECIFICATION OR DESCRIPTION WHEREVER APPEARING IS WARRANTED BY MANUFACTURER EXCEPT TO THE EXTENT SET FORTH IN THIS LIMITED WARRANTY. ANY IMPLIED WARRANTY PROTECTION ARISING UNDER THE LAWS OF ANY STATE, INCLUDING IMPLIED WARRANTY OF MERCHANTABILITY OR FITNESS FOR A PARTICULAR PURPOSE OR USE, IS HEREBY LIMITED IN DURATION TO THE DURATION OF THIS LIMITED WARRANTY.

Neither dealers nor the retail establishment selling this product has any authority to make any additional warranties or to promise remedies in addition to or inconsistent with those stated above. Manufacturer's maximum liability, in any event, shall not exceed the documented purchase price of the product paid by the original consumer. This warranty only applies to units purchased from an authorized retailer and or re-seller. NOTE: Some states do not allow an exclusion or limitation of incidental or consequential damages, so some of the above limitations or exclusions may not apply to you; this limited warranty gives you specific legal rights as set for herein. You may also have other rights which vary from state to state.

If you wish to obtain performance of any obligation under this limited warranty, you should write to:

Nexgrill Customer Relations
5270 Edison Avenue,
Chino, CA 91710

All consumer returns, parts orders, general questions, and troubleshooting assistance can be acquired by calling UK: 02392 -322880