

Product Guide Model 4651330

IMPORTANT: Fill out the product record information below.

Serial Number _____
See rating label on grill for serial number.

Date Purchased _____

For support and to register your grill, please visit us at www.charbroil.com

If you have questions or need assistance during assembly, please call **1-800-241-7548**.

Estimated assembly time: 30 minutes

THIS GRILL IS FOR OUTDOOR USE ONLY.

DANGER

If you smell gas:

1. Shut off gas to the appliance.
2. Extinguish any open flame.
3. Open lid.
4. If odor continues, keep away from the appliance and immediately call your gas supplier or your fire department.

Failure to follow these instructions could result in fire or explosion which could cause property damage, personal injury or death.

WARNING

1. Do not store or use gasoline or other flammable liquids or vapors in the vicinity of this or any other appliance.
2. An LP cylinder not connected for use shall not be stored in the vicinity of this or any other appliance.

WARNING

This manual contains important information necessary for the proper assembly and safe use of the appliance.

Read and follow all warnings and instructions before assembling and using the appliance.

Follow all warnings and instructions when using the appliance.

Keep this manual for future reference

CAUTION

Some parts may contain sharp edges — especially as noted in the manual! Wear protective gloves if necessary.

INSTALLER/ASSEMBLER: Leave these instructions with consumer.

CONSUMER: Keep this manual for future reference.

WARNING

**MOST SURFACES ON THIS UNIT ARE HOT WHEN IN USE.
USE EXTREME CAUTION.
KEEP OTHERS AWAY FROM UNIT.
ALWAYS WEAR PROTECTIVE CLOTHING TO PREVENT INJURY.**

TABLE OF CONTENTS

Product Record Information	1
Safety Symbols	2
Installation Safety Precautions	3
Use and Care	3-6
Food Safety	6
Limited Warranty	7
Parts List/ Parts Diagram	8
Assembly	9-11
Troubleshooting	12
Registration Card	13

Safety Symbols

The symbols and boxes shown below explain what each heading means. Read and follow all of the messages found throughout the manual.

	WARNING	
<p>WARNING: Indicates an potentially hazardous situation which, if not avoided, could result in death or serious injury.</p>		

	DANGER	
<p>DANGER: Indicates an imminently hazardous situation which, if not avoided, will result in death or serious injury.</p>		

	CAUTION	
<p>CAUTION: Indicates a potentially hazardous situation or unsafe practice which, if not avoided, may result in minor or moderate injury.</p>		

	CAUTION	
<ul style="list-style-type: none"> • For residential use only. Not intended for commercial use. • Do not leave appliance unattended. Keep children and pets away from appliance at all times. 		

	DANGER	
<ol style="list-style-type: none"> 1. Never operate this appliance unattended. 2. Never operate this appliance within 10ft (3m) of any structure, combustible material or other gas cylinder. 3. Never operate this appliance within 25 ft (7.5 m) of any flammable liquid. 4. If a fire should occur, keep away from the appliance and immediately call your fire department. Do not attempt to extinguish an oil or grease fire with water. 		
<p>Failure to follow these instructions could result in fire, explosion or burn hazard, which could cause property damage, personal injury or death.</p>		

	CAUTION	
<p>For residential use only. Do not use for commercial cooking.</p>		

THIS GRILL IS FOR OUTDOOR USE ONLY.

	WARNING	
<p>CALIFORNIA PROPOSITION 65</p> <ol style="list-style-type: none"> 1. Combustion by-products produced when using this product contain chemicals known to the State of California to cause cancer, birth defects, and other reproductive harm. 2. This product contains chemicals, including lead and lead compounds, known to the State of California to cause cancer, birth defects or other reproductive harm. <p><i>Wash your hands after handling this product.</i></p>		

	WARNING	
<p>Do not attempt to repair or alter the regulator/valve for any “assumed” defect. Any modification to this assembly will void your warranty and create the risk of a gas leak and fire. Use only authorized replacement parts supplied by manufacturer.</p>		

Installation Safety Precautions

- Use grill, as purchased, only with LP (propane) gas and the regulator/valve assembly supplied.
- Grill installation must conform with local codes, or in their absence of local codes, with either the **National Fuel Gas Code, ANSI Z223.1/ NFPA 54**. Storage and handling of liquefied petroleum gasses must conform to LP Gas Code **ANSI / NFPA 58**. Grill is not for use in or on recreational vehicles and/or boats.
- All electrical accessories (such as rotisserie) must be electrically grounded in accordance with local codes, or **National Electrical Code, ANSI / NFPA 70**. Keep any electrical cords and/or fuel supply hoses away from any hot surfaces.
- This grill is safety certified for use in the United States only. Do not modify for use in any other location. Modification will result in a safety hazard.
- **Do not leave appliance unattended. Keep children and pets away from appliance at all times.**

Safety Tips

- ♦ The use of alcohol, prescription or nonprescription drugs may impair the consumer's ability to properly assemble or safely operate the appliance.
- ♦ When grill is not in use, disconnect 1 lb. cylinder.
- ♦ Never move grill while in operation or still hot. Allow the appliance to cool before moving or storing.
- ♦ The regulator may make a humming or whistling noise during operation. This will not affect safety or use of grill.
- ♦ If you have a grill problem see the Troubleshooting Section.
- ♦ Light burners. Check to make sure they are lit, close the lid and warm up grill on high for 6 minutes. Curing of paint and parts will produce an odor only on first lighting.
- ♦ Grill is not intended for and should never be used as a heater.
- ♦ Clean grill often, preferably after each cookout. If a bristle brush is used to clean any of the grill cooking surfaces, ensure no loose bristles remain on cooking surfaces prior to grilling. It is not recommended to clean cooking surfaces while grill is hot.
- ♦ Use long-handled barbecue utensils and oven mitts to avoid burns and splatters.
- ♦ If the regulator frosts, turn off grill and LP cylinder valve immediately. This indicates a problem with the cylinder and it should not be used on any product. Return to supplier!

USE AND CARE



WARNING



For Safe Use of Your Grill and to Avoid Serious Injury:

- Do not let children operate or play near grill.
- Keep grill area clear and free from materials that burn (i.e. gasoline, propane, or any other flammable liquid or gas).
- Do not block holes in bottom or back of grill.
- Check burner flames regularly.
- Never use regulator from this grill with any other LP appliance.
- When cooking, the appliance must be on a level surface in an area clear of combustible material.
- Use grill only in well-ventilated space. NEVER use in enclosed space such as carport, garage, porch, covered patio, or under an overhead structure of any kind.
- Do not use charcoal or ceramic briquets in a gas grill. *(Unless briquets are supplied with your grill.)*
- This appliance is not intended for and should never be used as a heater.
- **Use grill at least 2 ft. from any wall or surface.** Maintain 10 ft. clearance to objects that can catch fire or sources of ignition such as pilot lights on water heaters, live electrical appliances, etc..

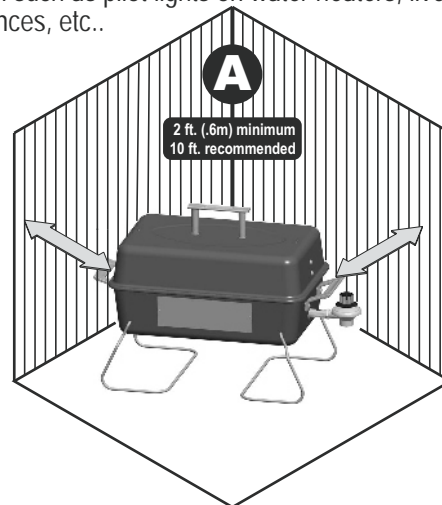

• Apartment Dwellers:

Check with management to learn the requirements and fire codes for using an LP gas grill in your apartment complex. If allowed, use outside on the ground floor with a three (3) foot clearance from walls or rails. Do not use on or under balconies.

- **NEVER attempt to light burner with lid closed. A buildup of non-ignited gas inside a closed grill is hazardous.**
- **Never operate grill with LP cylinder out of correct position specified in assembly instructions**

LP (Liquefied Petroleum Gas)

- Is nontoxic, odorless and colorless when produced. **For Your Safety**, LP gas has been given an odor (similar to rotten cabbage) so that it can be smelled.
- **Lp gas is highly flammable and may ignite unexpectedly when mixed with air.**

Propane Cylinder Use (1 lb. Disposable)

- Use only cylinder marked "Propane Fuel".
- Cylinder must be constructed and marked in accordance with the specifications for LP-gas cylinders of the U.S. Department of Transportation (DOT) or the National Standard of Canada, CAN/CSA-B339, Cylinders, Spheres and Tubes for the Transportation of Dangerous Goods.
- Save cylinder cap and reinstall when not in use.
- Cylinder supply system must be arranged for vapor withdrawal. Gas cylinder must be upright in use.

Propane Gas Cylinders

- Your grill is designed to operate with one 16.4 oz. disposable cylinder (Dot 39 Cylinder) that is 7 3/8" high (not included).

Do not attempt to refill any 16.4 oz. disposable fuel cylinders.

- The cylinder must be installed, transported and stored in an upright position and should not be dropped or handled roughly.

- When the appliance is to be stored indoors, the propane gas cylinder must be disconnected from the appliance.

- When the propane gas cylinder is not disconnected from the appliance, the appliance and cylinder must be stored outdoors in a well-ventilated space.

- The cylinder should never be transported or stored where temperature can reach 125 °F (51 °C).

- Cylinders must be stored outdoors out of the reach of children.

- A disconnected LP cylinder in storage or being transported must have a safety cap installed. Failure to use safety cap as directed may result in serious personal injury and/or property damage.

- Do not store an LP cylinder in enclosed spaces such as a carport, garage, porch, covered patio or other building.

Propane Cylinder Installation/Removal

Propane Cylinder Installation:

1. Remove cap from end of Propane cylinder (sold separately).
2. Cap should be kept on cylinder when not in use to prevent dirt and debris from entering Regulator/Valve.
3. Check end of cylinder attachment for dirt and debris. Clean out if necessary.
4. Insert threaded end of Propane Cylinder into Regulator/Valve and hand-tighten turning cylinder clockwise as shown below.
DO NOT USE TOOLS! Over tightening can damage threads on Regulator/Valve.

5. Perform a leak test.

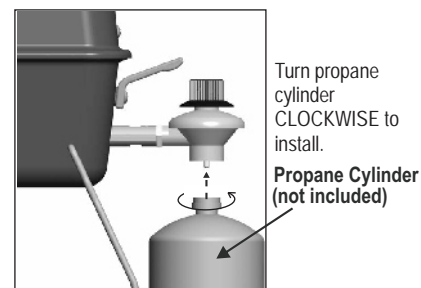

Propane Cylinder Removal:

1. Turn regulator OFF.
2. Allow Grill to cool.
3. Remove the propane cylinder by turning counter-clockwise until disengaged from the Regulator/Valve.
4. Install cap on cylinder. Cap should be kept on cylinder when not in use to prevent dirt and debris from entering Regulator/Valve.

Leak Testing (1 lb. Disposable) **IMPORTANT!**

- During leak test, keep grill away from open flames or sparks and do not smoke. Grill must be leak tested outdoors in a well ventilated area.
- Leak test must be repeated each time gas cylinder is replaced or after storage.

Materials needed include clean paint brush and 50/50 soap and water solution. Use mild soap and water. **Do not use household cleaning agents.** Damage to components can result.

1. Be sure **control knob** on regulator is in "OFF" position.
2. Brush soapy solution onto **connection** between gas cylinder and regulator at **(A)**.

If growing bubbles appear, there is a leak. Retighten connection and repeat steps 1 and 2.



If you cannot stop a leak, remove gas cylinder from regulator and check for damaged threads, dirt and debris on regulator and gas cylinder. Also check to see if anything is obstructing flow of gas at regulator and gas cylinder openings. Remove any obstruction that may be found and repeat leak test. **If threads are damaged on either regulator or gas cylinder, replace.** Order new parts by giving the serial, model number and name of items needed to the Grill Service Center at **1-800-232-3398**.

 **CAUTION** 

SPIDER ALERT!

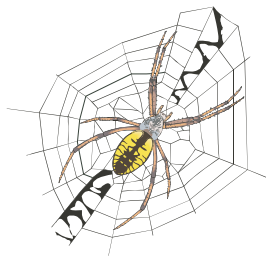

If you notice that your grill is getting hard to light or that the flame isn't as strong as it should be, take the time to check and clean the burner.

In some areas of the country, spiders or small insects have been known to create "flashback" problems. The spiders spin webs, build nests and lay eggs in the grill's burner tube obstructing the flow of gas to the burner. The backed-up gas can ignite in the burner tube. This is known as a flashback and it can damage your grill and even cause injury.

To prevent flashbacks and ensure good performance the burner and burner tube should be removed from the grill and cleaned before use whenever the grill has been idle for an extended period.

IF YOU EXPERIENCE THE FOLLOWING:

1. Smell gas.
2. Burner will not light.
3. A small yellow flame from burner (should be blue).
4. Fire coming from around or behind control knob.

**STOP!
IMMEDIATELY TURN OFF GAS AT LP CYLINDER!**

1. Wait for grill to cool.
2. Use a 12" pipe cleaner to clean out the burner tube.

Lighting Instructions

Important! Remove or raise lid to open position.

Attempting to light burner with lid closed may cause an explosion. Do not expose any part of your body or clothing directly above cooking area when lighting.

1. From beneath the grill, place lighted wooden match up through lighter/ventilation hole in center of bottom.
2. While holding match in place, turn control knob to lighting position. Grill will ignite.
3. Observe burner flames through openings in heat distribution plate. Make sure burner ignites and stays lit on both sides.
4. Preheat grill for 6 minutes with lid closed. Using control knob on Regulator/Valve, adjust flame to desired height for cooking.

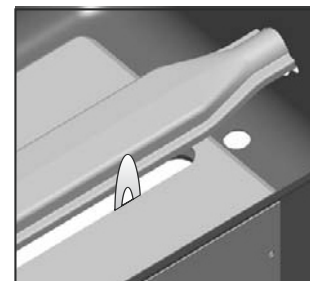



 **CAUTION** 

If ignition does NOT occur in 5 seconds, turn the burner control OFF, wait 5 minutes and repeat the lighting procedure. If the burner does not ignite with the valve open, gas will continue to flow out of the burner and could accidentally ignite with risk of injury.

Burner Flame Check

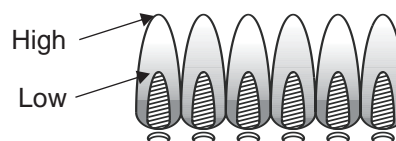
Light burner. Make sure burner stays lit while rotating the control knob from HIGH to LOW. Always check flame prior to each use.



	CAUTION	
<ul style="list-style-type: none"> • Putting out grease fires by closing the lid is not possible. Grills are well ventilated for safety reasons. • Do not use water on a grease fire. Personal injury may result. If a grease fire develops, turn knobs and LP cylinder off. • Do not leave grill unattended while preheating or burning off food residue on HI. If grill has not been regularly cleaned, a grease fire can occur that may damage the product. 		

Before Cooking For The First Time

Operate grill for 15 minutes with the grill lid closed and the gas control on HIGH. This will heat-clean internal components and eliminate odor from paint finish of grill.

Turning Grill Off

- After cooking, turn the grill off by rotating the control knob to OFF. Control knob should pop up in the OFF position. If control knob does not pop up, disconnect cylinder to turn grill off and replace the Regulator/Valve.
- Allow grill to cool completely before storing.

Storing Grill

- Allow grill to cool completely.
- Remove Propane Cylinder and install protective cap over outlet threads.
- Remove Regulator/Valve from grill to help keep dirt out of the propane cylinder probe.
- Store Regulator/Valve in a heavy plastic bag and place inside grill.
- Fold legs up over top of grill with lid in closed position.

Grill Maintenance

- Allow grill to cool before cleaning. Frequency of cleaning is determined by how often grill is used.
- **DO NOT** use self-cleaning oven to clean any grill part. Extreme heat would remove any chrome plating and cause premature rusting.
- Meat drippings will solidify in bottom of grill after a few uses. This residue should be removed regularly. Failure to do so could cause overflow at bottom vent openings and increase the chance of a grease fire.
- When cleaning grill, cover work area with newspaper. Remove grill lid and cooking grate. Loosen residue with scraper or putty knife. Wipe away loosened residue with paper towels.
- Inside surface of grill may be cleaned with a strong solution of detergent and water applied with a scrub brush. Cooking grate may be cleaned with a wire brush. Thoroughly rinse grill with water and allow to completely air-dry before using again.
- Place cooking grate and lid onto grill.

Food Safety

Food safety is a very important part of enjoying the outdoor cooking experience. To keep food safe from harmful bacteria, follow these four basic steps:

Clean: Wash hands, utensils, and surfaces with hot soapy water before and after handling raw meat and poultry.

Separate: Separate raw meats and poultry from ready-to eat foods to avoid cross contamination. Use a clean platter and utensils when removing cooked foods.

Cook: Cook meat and poultry thoroughly to kill bacteria. Use a thermometer to ensure proper internal food temperatures.

Chill: Refrigerate prepared foods and leftovers promptly.

For more information call: USDA Meat and Poultry Hotline at 1-800-535-4555 In Washington, DC (202) 720-3333, 10:00 am-4:00 pm EST.

LIMITED WARRANTY

This warranty only applies to units purchased from an authorized retailer. Manufacturer warrants to the original consumer-purchaser only that this product shall be free from defects in workmanship and materials after correct assembly and under normal and reasonable home use for the periods indicated below beginning on the date of manufacture*. The manufacturer reserves the right to require that defective parts be returned, postage and or freight pre-paid by the consumer for review and examination.

SCOPE OF COVERAGE

ALL PARTS

PERIOD OF COVERAGE

90 DAYS

TYPE OF FAILURE COVERAGE

**PERFORATION, MANUFACTURING,
AND MATERIAL DEFECTS ONLY**

*Note: The warranty period of coverage will be extended to begin on the date of purchase on the condition that the consumer registers the product and supplies a copy of the original dated sales receipt.

The original consumer-purchaser will be responsible for all shipping charges for parts replaced under the terms of this limited warranty.

This limited warranty is applicable in the United States and Canada only, is only available to the original owner of the product and is not transferable. Manufacturer requires proof of your date of purchase. Therefore, you should retain your sales slip or invoice. Registering your product is not a substitute for proof of purchase and the manufacturer is not responsible for or required to retain proof of purchase records.

This limited warranty applies to the functionality of the product ONLY and does not cover cosmetic issues such as scratches, dents, corruptions or discoloring by heat, abrasive and chemical cleaners or any tools used in the assembly or installation of the appliance, surface rust, or the discoloration of stainless steel surfaces.

This limited warranty will not reimburse you for the cost of any inconvenience, food, personal injury or property damage.

ITEMS MANUFACTURER WILL NOT PAY FOR:

1. Shipping cost, standard or expedited, for warranty and replacement parts
2. Service calls to your home.
3. Repairs when your product is used for other than normal, single-family household or residential use.
4. Damage, failures, or operating difficulties resulting from accident, alteration, careless handling, misuse, abuse, fire, flood, acts of God, improper installation or maintenance, installation not in accordance with electrical or plumbing codes, or use of products not approved by the manufacturer.
5. Any food loss due to product failures or operating difficulties.
6. Replacement parts or repair labor costs for units operated outside the United States or Canada.
7. Pickup and delivery of your product.
8. Repairs to parts or systems resulting from unauthorized modifications made to the product.
9. The removal and/or reinstallation of your product.

DISCLAIMER OF IMPLIED WARRANTIES and LIMITATION OF REMEDIES

Repair or replacement of defective parts is your exclusive remedy under the terms of this limited warranty. Manufacturer will not be responsible for any consequential or incidental damages arising from the breach of either this limited warranty or any applicable implied warranty, or for failure or damage resulting from acts of God, improper care and maintenance, grease fire, accident, alteration, replacement of parts by anyone other than Manufacturer, misuse, transportation, commercial use, abuse, hostile environments (inclement weather, acts of nature, animal tampering), improper installation or installation not in accordance with local codes or printed manufacturer instructions.

THIS LIMITED WARRANTY IS THE SOLE EXPRESS WARRANTY GIVEN BY THE MANUFACTURER. NO PRODUCT PERFORMANCE SPECIFICATION OR DESCRIPTION WHEREVER APPEARING IS WARRANTED BY MANUFACTURER EXCEPT TO THE EXTENT SET FORTH IN THIS LIMITED WARRANTY. ANY IMPLIED WARRANTY PROTECTION ARISING UNDER THE LAWS OF ANY STATE, INCLUDING IMPLIED WARRANTY OF MERCHANTABILITY OR FITNESS FOR A PARTICULAR PURPOSE OR USE, IS HEREBY LIMITED IN DURATION TO THE DURATION OF THIS LIMITED WARRANTY.

Neither dealers nor the retail establishment selling this product has any authority to make any additional warranties or to promise remedies in addition to or inconsistent with those stated above. Manufacturer's maximum liability, in any event, shall not exceed the purchase price of the product paid by the original consumer.

NOTE: Some states do not allow an exclusion or limitation of incidental or consequential damages, so some of the above limitations or exclusions may not apply to you. This limited warranty gives you specific legal rights as set forth herein. You may also have other rights which vary from state to state. In the state of California only, if refinishing or replacement of the product is not commercially practicable, the retailer selling this product or the Manufacturer will refund the purchase price paid for the product, less the amount directly attributable to use by the original consumer-purchaser prior to discovery of the nonconformity. In addition, in the state of California only, you may take the product to the retail establishment selling this product in order to obtain performance under this limited warranty.

If you wish to obtain performance of any obligation under this limited warranty, you should write to:

**Consumer Relations
P. O. Box 1240
Columbus, GA 31902-1240**

Consumer returns will not be accepted unless a valid Return Authorization is first acquired. Authorized returns are clearly marked on the outside of the package with an RA number and the package is shipped freight/postage pre-paid. Consumer returns that do not meet these standards will be refused.

Parts List

Key	Qty	Description
A	1	Lid Handle
B	1	Lid
C	2	Hinge Brackets
D	1	Cooking Grate
E	1	Heat Distribution Plate
F	1	Burner
G	1	Heat Resistant Shield
H	1	Bottom
I	2	Side Handle
J	1	Regulator/Valve Set
K	2	Leg
	1	Hardware Bag
	1	Assembly Manual - English
	1	Assembly Manual - Spanish
	1	Assembly Manual - French

NOTE: Some grill parts shown in the assembly steps may differ slightly in appearance from those on your particular grill model. However, the method of assembly remains the same.

Tools required for assembly:

Adjustable Wrench - Not provided

Phillips Screwdriver - Not provided

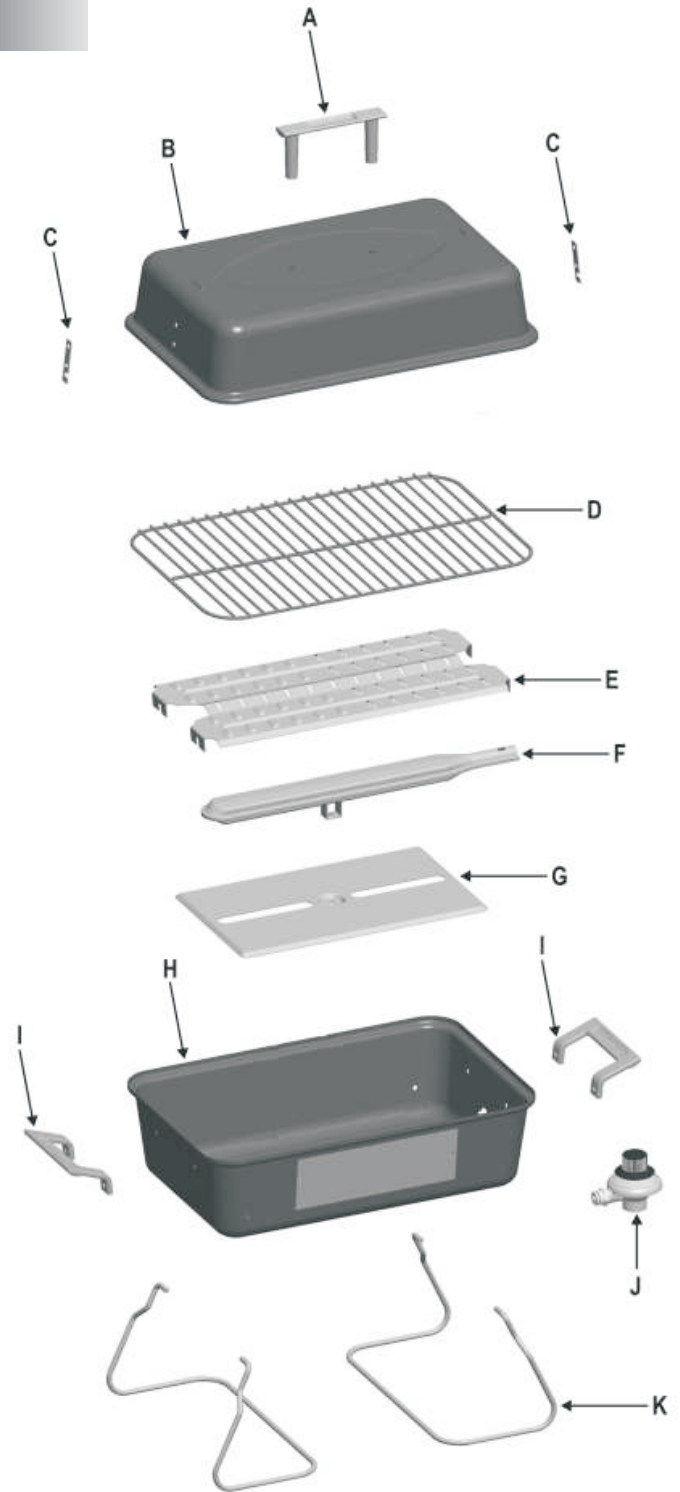

Hardware

Hardware is shown actual size.



(L)
Fiber Washer
Qty. 6



(M)
1/4-20 x 3/8" Screw
Qty. 3



(N)
#10-24 Nut
Qty. 8



(O)
#10-24 x 3/4" Screw
Qty. 4



(P)
#10-24 x 3/8" Screw
Qty. 4



(Q)
1/4" Flat Washer
Qty. 2

Assembly

1

- Position Heat Shield (G) as shown at right below and place into Bottom (H).
- Insert narrow end of Burner (F) through large hole in side of Bottom (H) and rest burner bracket on Shield (G).
- Insert one 1/4-20 x 3/8" Screw (M) through Bottom (H), Shield (G) and into burner bracket.



Some parts may contain sharp edges! Wear protective gloves if necessary.

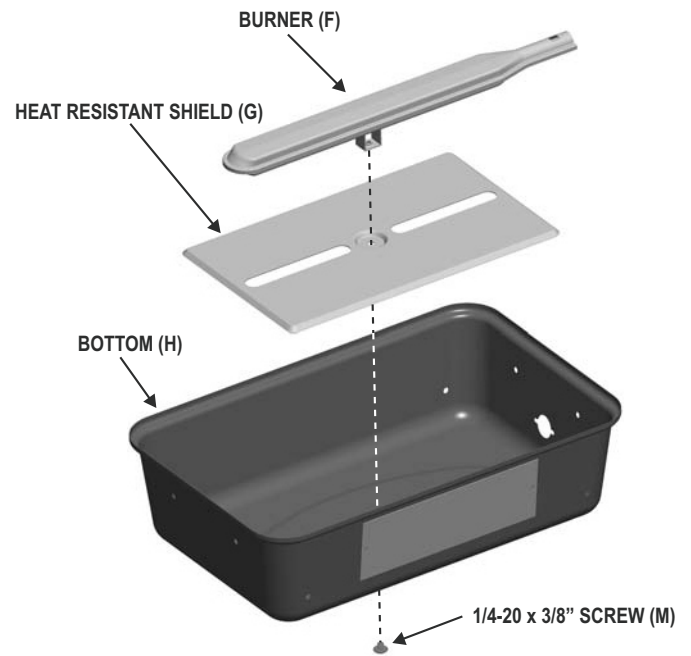

2

- Position Legs (K) as shown at right.
- Spread ends of Legs (K) slightly and insert into holes in front and rear of Bottom (H).

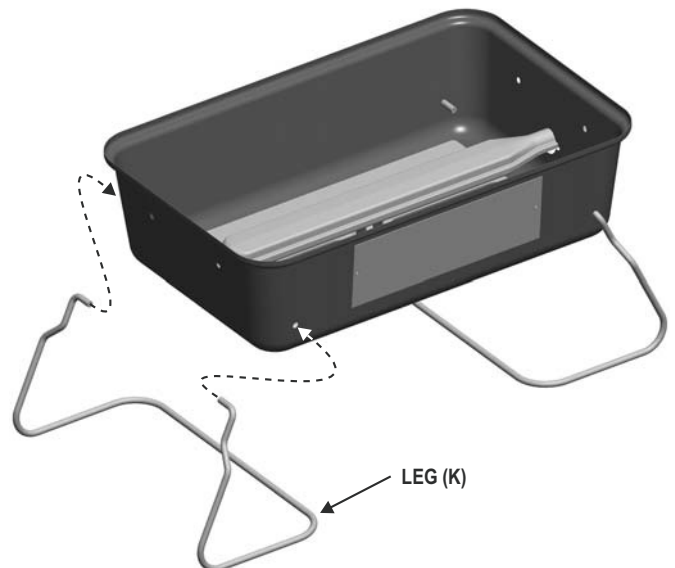

Assembly (Con't.)

3

- Assemble Side Handles (I) to Bottom (H) using two each #10-24 x 3/4" Screws (O), Fiber Washers (L) and #10-24 Hex Nuts (N) per Handle (I).
- Rest the notches on ends of Heat Distribution Plate (E) on Side Handles Screws (O) inside Bottom (H).

PLEASE NOTE: This table top propane gas grill has been designed to work effectively without the use of lava rocks. The reflective heat distribution plate efficiently vaporizes the food juices to add that great barbecue taste to your food. The plate also stays in place during transportation to eliminate the messy "set-up" required with lava rocks each time you use your grill.

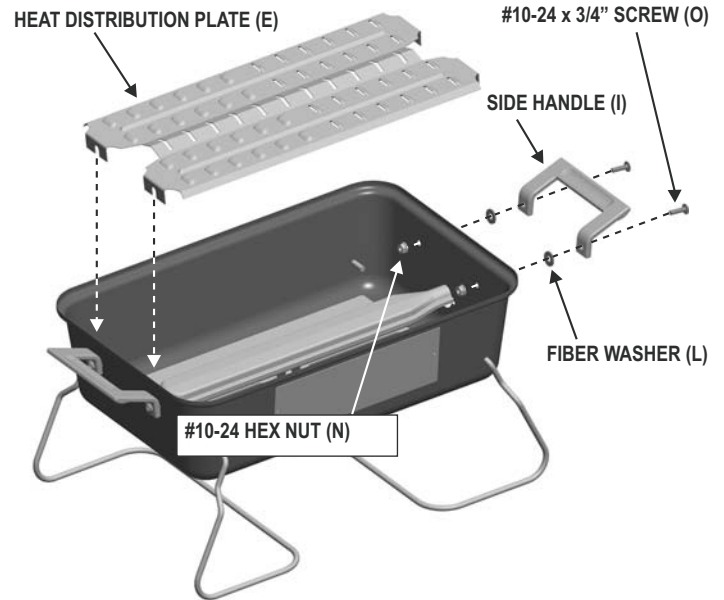

4

- Attach Lid Handle (A) to Lid (B) using two each Fiber Washers (L), 1/4" Flat Washers (Q) and 1/4-20 x 3/8" Screws (M).

NOTE: Fiber Washers (L) should be between Handle (A) and Lid (B).

- Install Hinge Brackets (C) to inside of Lid (B) using two each #10-24 x 3/8" Screws (P) and #10-24 Hex Nuts (N) per bracket. Make sure notches in Hinge Brackets (C) are toward the bottom edge of Lid (B) and are facing the same direction.
- Place Cooking Grate (D) into Bottom (H).
- Place Lid (B) onto Bottom (H).

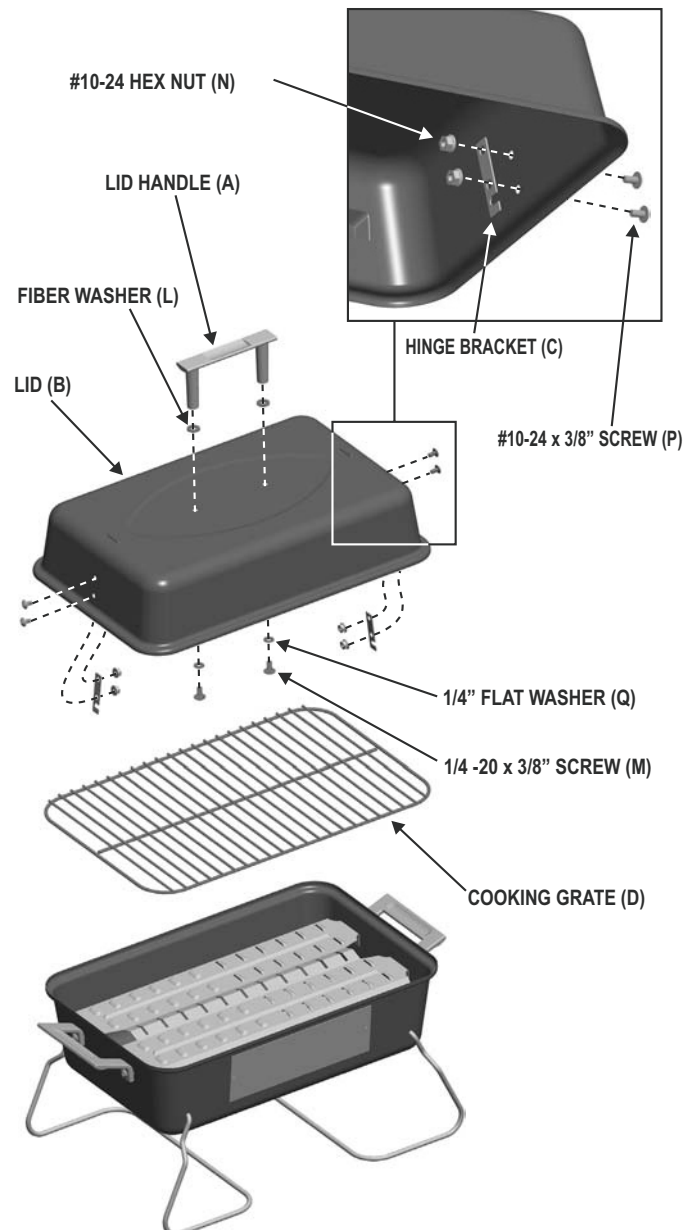

Assembly (Con't.)

5

- Before assembly, inspect Regulator (J) for damage, dirt or debris accumulation. Clean out if present.
- With knob **pointing down**, insert Regulator/Valve (J) into end of Burner (F).
- Notch in Regulator/Valve (J) MUST engage dimple in end of Burner (F).**
- Once Regulator/Valve (J) has **completely engaged** Burner (F), turn Regulator/Valve (J) **clockwise** to lock in position with knob pointing up.

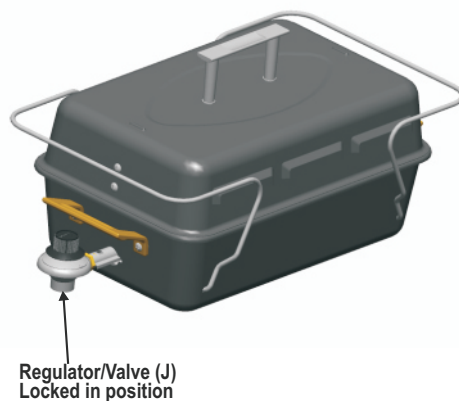
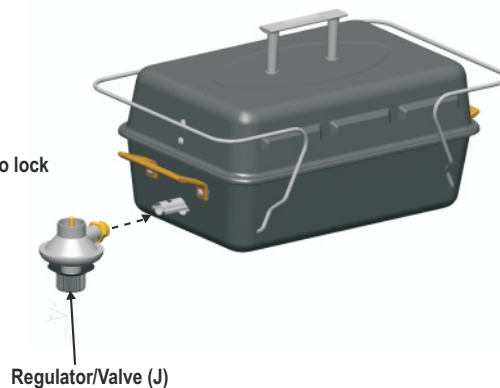
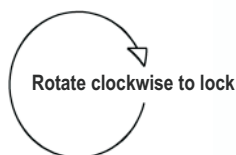

6

- Remove cap from end of Propane cylinder (sold separately). Cap should be kept on cylinder when not in use to prevent dirt and debris from entering Regulator/Valve (J). Check end of cylinder attachment for dirt and debris. Clean out if necessary.
- Insert threaded end of Propane Cylinder into Regulator/Valve (J) and hand-tighten. **DO NOT USE TOOLS!** Over tightening can damage threads on Regulator/Valve (J).
- Perform a leak test.

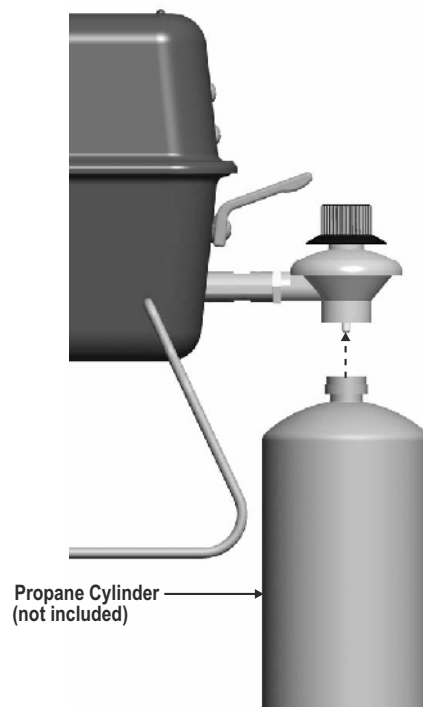

EMERGENCIES: If a gas leak cannot be stopped, or a fire occurs due to gas leakage, call the fire department.

Troubleshooting

Problem	Possible Cause	Prevention/Solution
Burner will not Light.	<ul style="list-style-type: none"> • Out of Propane • Regulator not fully tightened to cylinder. • Inspect burner for obstructions. 	<ul style="list-style-type: none"> • Replace Cylinder. • Retighten cylinder. • See 'Care and Use' for burner cleaning instructions.
Flames burns out on "LOW".	<ul style="list-style-type: none"> • Grill not sufficiently preheated before turning to "LOW". 	<ul style="list-style-type: none"> • See 'Care and Use' section "Before Cooking For The First Time'.

The following are trademarks registered by W.C. Bradley Co. in the U.S. Patent and Trademark Office: Caldera®; Charcoal2Go®; Char-Broil®; American Gourmet®; Bandera®; Brush Hawg®; CB 940®; Char-Diamonds®; Char-Broil Charcoal/Gas®; Everybody Grills®; Grill 2 Go®; Grill 2 Go® Express®; Grill Lovers®; Infrared Grilling That's All About U®; Keepers of the Flame®; Magneto®; New Braunfels Smoker Company®; Patio Bistro®; Patio Caddie®; Patio Kitchen®; Pro-Sear®; RED®; Quantum®; Santa Fe®; Sear and Grill®; Sierra®; Signature Series®; Sure2Burn®; The Big Easy®; U®; Wild West Tradition®; and the following marks:



The following are trademarks of W.C. Bradley Co.: America's Legendary Barbeque Company™; Advantage Series™; Auto-Clean™; Chef Tested™; Commercial Series™; Designer Series™; Diamond Flame™; Double Chef™; Everybody Outside™; FastStart™; FlavorMaster™; Front Avenue™; Grill 2 Go® Advantage™; Grill 2 Go® Ice™; Hog and Yard Bird™; H2O Smoker™; Infrared. Grilling's Juicy Little Secret™; Incredible Taste. Infallible Results™; Infrared Inside™; Let's Grill Something Together™; Longhorn™; Precision Flame™; Quick2Burn™; QuickSet™; Ready When You Are™; Season, Set, And Savor™; Sizzle On The Grill™; SureFire™; Torchfork™; Trentino™; Universal Grill Parts™; You Bring the Party™ TEC™ is a trademark of Tec Infrared Grills.

TM.REVISION.08

Please register your product online at:

www.charbroil.com/register

(If you register online, you do not need to send in this registration card.)

PLEASE FILL OUT THIS CARD AND ATTACH A COPY OF YOUR SALES RECEIPT. RETURN IT WITHIN 10 DAYS OF PURCHASE. FAILURE TO RETURN MAY AFFECT YOUR WARRANTY COVERAGE. FOR WARRANTY SERVICE PROOF OF PURCHASE WILL BE REQUIRED. THIS WARRANTY IS NON-TRANSFERABLE.

LENE ESTA TARJETA Y DEVUELVALA DENTRO DE LOS 10 DÍAS DE LA COMPRA. SI NO LA DEVUELVE, PUEDE VERSE AFECTADA SU COBERTURA DE GARANTIA. PARA EL SERVICIO DE GARANTIA ES NECESARIO QUE PRESENTE SU COMPROBANTE DE COMPRA. CONSERVE LA FACTURA. ESTA GARANTIA ES INTRANSFERIBLE.

VEUILLEZ COMPLETER CETTE CARTE ET LA RETOURNER DANS LES 10 JOURS SUIVANT L'ACHAT. LA COUVERTURE DE VOTRE GARANTIE POURRAIT EN ETRE AFFECTEE SI VOUS NE LE FAITES PAS. POUR OBTENIR LE SERVICE SOUS GARANTIE, UNE PREUVE D'ACHAT DOIT ETRE PRESENTEE. VEUILLEZ CONSERVER VOTRE FACTURE. LA PRESENTE GARANTIE N'EST PAS TRANSFERABLE.

1 First Name/Nombre/Prénom Initial/Inicial/Initiale Last Name/Apellido/Nom de famille

Address (number and street)/Dirección (número y calle)/Adresse (numéro et rue) Apt Number/Nº de apart./Nº d'appt.

City/Ciudad/Ville State/Estado/Province Zip Code/Código Zip/Code postal

2 E-mail Address/Dirección de correo electrónico/Adresse électronique

If you voluntarily provide us with your email address, you give us permission to use your email address to send you offers that may interest you.

Si nos informa voluntariamente su dirección de correo electrónico, nos da permiso para usarlo a fin de enviarle ofertas que pueden interesarle.

Si vous choisissez de nous fournir votre adresse électronique, vous nous donnez la permission de l'utiliser pour vous faire part d'offres spéciales susceptibles de vous intéresser.

(Example: your name @ your host.com) (Ejemplo: su nombre@su host.com) (Exemple : votre nom@votre hôte.com)

10 Attach copy of your sales receipt here
Adjunte aquí la copia de su recibo de compra
Veillez attacher une copie de votre reçu ici.

3 Phone Number/Número telefónico/Numéro de téléphone

6 Date of Purchase/Fecha de compra/Date de l'achat

4 **IMPORTANT! ¡IMPORTANTE! IMPORTANT!**
Write Serial Number and Model Number in spaces below.
Escriba en los espacios de abajo el número de serie y el número de modelo.
Inscrivez le numéro de série et le numéro de modèle dans les espaces ci-dessous.

7 Store Name/Nombre de la tienda/Nom du magasin

8 Purchase Price/Precio de compra/Prix d'achat

\$ _____ .00

5 Your Gender/Sexo/Sexe : 1. Male/Masculino/Masculin 2. Female/Femenino/Féminin

9 Which product are you registering?

¿Qué producto está registrando?

Quel produit enregistrez-vous?

1. Gas Grill/Parrilla a gas/Gril au gaz
2. Electric Grill/Parrilla eléctrica/Gril électrique
3. Smoker/Ahumador/Fumoir
4. Charcoal Grill/Parrilla a carbón/Barbecue au charbon
5. Charcoal Smoker/Ahumador a carbón/Fumoir au charbon
6. Outdoor Fireplace/Chimenea para exteriores/Foyer extérieur
7. Cooker/Fryer / Cocina/freidora / Cuiseur/Friteuse
8. Other/Otro/Autre

Mail to: / Envíelo a:
Consumer Warranty Service
P. O. Box 1240
Columbus, GA 31902-1240

Thank you for completing this questionnaire. Your answers will help us and other companies reach you with offers that may interest you. If you prefer not to receive these offers, please check here .

Gracias por completar este cuestionario. Sus respuestas nos ayudarán, a nosotros y a otras compañías, a llegar a usted con ofertas que puedan resultarle de interés. Si prefiere no recibir estas ofertas, por favor marque aquí .

Merci d'avoir bien voulu remplir ce questionnaire. Vos réponses nous aideront et aideront d'autres compagnies à vous communiquer des offres spéciales susceptibles de vous intéresser. Si vous préférez ne pas recevoir d'informations concernant ces offres spéciales, veuillez cocher ici .

Here's what you can find at www.charbroil.com

- Register your Char-Broil® product
- Get information about our products
- Our replacement parts
- Reliable customer support
- Delicious recipes
- Char-Broil® on-line store
- *Sizzle On The Grill*™ E-newsletter
- And much more!

Please visit us at www.charbroil.com and click on the *Buy Online* link to find grilling tools and accessories, maintenance items, covers, grill parts, Char-Broil® grills and cookers, and of course, the famous Oklahoma Joe's® sauces, rubs, and marinades. We also have a *Special Offers* section, so be sure to check often for specials deals.

In addition to the online store, charbroil.com offers you a wealth of information regarding Char-Broil® gas, charcoal, electric, and new infrared grills and cookers.

Be sure to check out our many grilling recipes and don't forget to sign up for our exciting newsletter *Sizzle on the Grill*™ to stay updated on new recipes, contests, and the latest happenings here at Char-Broil®.

Charbroil.com also offers on-line customer support for Char-Broil® products.

Thank you for support, and HAPPY GRILLING!

www.charbroil.com

For all your grilling needs!





Char-Broil® , LLC
P.O. Box 1240
Columbus, GA31902-1240
Printed in China