

**Use & Care Guide**  
**Manual de Uso y Cuidado**  
**Guide d'Utilisation et d'Entretien**  
English / Español / French

Models/Modelos/Modèles: 795.7219\*

# Kenmore Elite®

## Grab-N-Go

### Bottom Freezer Refrigerator

### Congelador Inferior Refrigerador

### Congélateur Inférieur Réfrigérateur

\* = color number, número de color, le numéro de la couleur



MFL62184467

Sears Brands Management Corporation  
Hoffman Estates, IL 60179 U.S.A.  
[www.kenmore.com](http://www.kenmore.com)  
[www.sears.com](http://www.sears.com)

Sears Canada Inc.  
Toronto, Ontario, Canada M5B 2C3  
[www.sears.ca](http://www.sears.ca)



# TABLE OF CONTENTS

|   |       |  |            |
|---|-------|--|------------|
| <b>Warranty</b> .....   | 3     | <b>► Freezer Section</b>               |            |
| <b>Protection Agreements</b> .....  | 4     | Extra Ice Bin .....                    | 28         |
| <b>Important Safety Instructions</b> .....  | 5-7   | Pullout Drawers .....                  | 29         |
| <b>Electrical &amp; Grounding Requirements</b> .....                                | 7     | Durabase.....                          | 29         |
| <b>Parts and Features</b> .....   | 8     | Durabase Divider .....                 | 29         |
| <b>Refrigerator Installation</b> .....  | 9-16  | <b>Water Filter</b> .....              | 30-33      |
| Unpacking Your Refrigerator.....  | 9     | <b>Care And Cleaning</b> .....         | 34-35      |
| Installation .....  | 10    | General Cleaning Tips .....            | 34         |
| Removing/Replacing Your Refrigerator and<br>Freezer Handles, Doors and Drawers..... | 11-15 | Exterior .....                         | 34         |
| Leveling and Door Alignment .....   | 16    | Inside Walls .....                     | 34         |
| <b>Using Your Refrigerator</b> .....  | 17-28 | Door Liner And Gaskets.....            | 34         |
| Setting the Controls .....  | 17-19 | Plastic Parts.....                     | 34         |
| In-Door Ice Bin .....   | 20    | Condenser Coils.....                   | 34         |
| Automatic Icemaker .....  | 21-22 | Light Bulb Replacement .....           | 35         |
| Food Storage Guide .....  | 23    | Power Interruptions .....              | 35         |
| <b>► Refrigerator Section</b>   |       | When You Go On Vacation .....          | 35         |
| Water Dispenser .....   | 24    | When You Move.....                     | 35         |
| Refrigerator Shelves.....   | 25    | <b>Connecting the Water Line</b> ..... | 36-38      |
| Humidity Controlled Crisper.....  | 26    | <b>Troubleshooting Guide</b> .....     | 39-46      |
| Temperature Controlled Pantry Drawer .....  | 26    | <b>Kenmore Connect</b> .....           | 47         |
| Grab-N-Go Case.....   | 27    | <b>Service</b> .....                   | Back Cover |
| Replacing the Air Filter .....  | 28    |  |            |

# WARRANTY



## REFRIGERATOR WARRANTY

### Kenmore Elite Limited Warranty

When this appliance is installed, operated and maintained according to all supplied instructions, the following warranty coverage applies. To arrange for warranty service, call 1-800-4-MY-HOME® (1-800-469-4663).

- For one year from the date of purchase, free repair will be provided if any non-consumable part of this appliance fails due to defective materials or workmanship. This coverage applies for only 90 days from the purchase date if this product is ever used for other than private household purposes.
- For five years from the date of purchase, a defective sealed refrigerant system will be repaired free of charge. This coverage applies for only one year from the date of purchase if this appliance is ever used for other than private household purposes.
- For ten years from the date of purchase, a defective compressor will be repaired free of charge. This coverage applies for only two years from the date of purchase if this appliance is ever used for other than private household purposes.

### **This warranty covers only defects in material and workmanship, and will NOT pay for:**

1. Consumable parts that can wear out from normal use, including but not limited to filters, belts, light bulbs, and bags.
2. A service technician to instruct the user in correct product installation, operation or maintenance.
3. A service technician to clean or maintain this product.
4. Damage to or failure of this product if it is not installed, operated or maintained according to the all instructions supplied with the product.
5. Damage to or failure of this product resulting from accident, abuse, misuse or use for other than its intended purpose.
6. Damage to or failure of this product caused by the use of detergents, cleaners, chemicals or utensils other than those recommended in all instructions supplied with the product.
7. Damage to or failure of parts or systems resulting from unauthorized modifications made to this product.

### **Disclaimer of implied warranties; limitation of remedies**

Customer's sole and exclusive remedy under this limited warranty shall be product repair as provided herein. Implied warranties, including warranties of merchantability or fitness for a particular purpose, are limited to one year or the shortest period allowed by law. Sears shall not be liable for incidental or consequential damages. Some states and provinces do not allow the exclusion or limitation of incidental or consequential damages, or limitation on the duration of implied warranties of merchantability or fitness, so these exclusions or limitations may not apply to you.

This warranty applies only while this appliance is used in the United States or Canada.

This warranty gives you specific legal rights, and you may also have other rights which vary from state to state.

**Sears Brands Management Corporation, Hoffman Estates, IL 60179  
Sears Canada Inc., Toronto, Ontario, Canada M5B 2C3**

# PROTECTION AGREEMENTS

## Master Protection Agreements

Congratulations on making a smart purchase. Your new Kenmore Elite® product is designed and manufactured for years of dependable operation. But like all products, it may require preventive maintenance or repair from time to time. That's when having a Master Protection Agreement can save you money and aggravation.

The Master Protection Agreement also helps extend the life of your new product. Here's what the Agreement\* includes:

- **Parts and labor** needed to help keep products operating properly **under normal use**, not just defects. Our coverage goes **well beyond the product warranty**. No deductibles, no functional failure excluded from coverage— **real protection**.
- **Expert service** by a force of more than **10,000 authorized Sears service technicians**, which means someone you can trust will be working on your product.
- **Unlimited service calls and nationwide service**, as often as you want us, whenever you want us.
- **"No-lemon" guarantee** – replacement of your covered product if four or more product failures occur within twelve months.
- **Product replacement** if your covered product can't be fixed.
- **Annual Preventive Maintenance Check** at your request – no extra charge.
- **Fast help by phone** – we call it **Rapid Resolution** – phone support from a Sears representative on all products. Think of us as a "talking owner's manual."

- **Power surge protection** against electrical damage due to power fluctuations.
- **\$250 Food Loss Protection** annually for any food spoilage that is the result of mechanical failure of any covered refrigerator or freezer.
- **Rental reimbursement** if repair of your covered product takes longer than promised.
- **25% discount** off the regular price of any non-covered repair service and related installed parts.

Once you purchase the Agreement, a simple phone call is all that it takes to schedule service. You can call at any time day or night, or schedule a service appointment online.

The Master Protection Agreement is a risk free purchase. If you cancel for any reason during the product warranty period, we will provide a full refund or a prorated refund anytime after the product warranty period expires. Purchase your Master Protection Agreement today!

**Some limitations and exclusions apply.**

**For prices and additional information in the U.S.A. call 1-800-827-6655.**

**\* Coverage in Canada varies on some items. For full details call Sears Canada at 1-800-361-6665.**

### Sears Installation Service

For Sears professional installation of home appliances, garage door openers, water heaters, and other major home items, in the **U.S.A. or Canada call 1-800-4-MY-HOME®**.

## PRODUCT RECORD

In the space below, record the date of purchase, model and serial number of your product. You will find the model and serial number printed on an identification label located on the interior liner of the refrigerator compartment. Have these items of information available whenever you contact Sears concerning your product.

Model No. \_\_\_\_\_

Date of Purchase \_\_\_\_\_

Serial No. \_\_\_\_\_

Save these instructions and attach your sales receipt for future reference.

# IMPORTANT SAFETY INSTRUCTIONS

## BASIC SAFETY PRECAUTIONS

This guide contains many important safety messages. Always **read and obey** all safety messages.



This is the safety alert symbol. It alerts you to safety messages that inform you of hazards that can kill or hurt you or others, or cause damage to the product.

All safety messages will be preceded by the safety alert symbol and the hazard signal word **DANGER**, **WARNING** or **CAUTION**. These words mean:

### **DANGER**

You **will** be killed or seriously injured if you do not follow instructions.

### **WARNING**

You **can** be killed or seriously injured if you do not follow instructions.

### **CAUTION**

Indicates an imminently hazardous situation which, if not avoided, **may** result in minor or moderate injury, or product damage.

All safety messages will identify the hazard, tell you how to reduce the chance of injury, and tell you what can happen if the instructions are not followed.

## **WARNING**

**To reduce the risk of fire, electric shock, or personal injury when using your product, basic safety precautions should be followed, including the following.**

**Read all instructions before using this appliance.**

- NEVER unplug your refrigerator by pulling on the power cord. Always grip the plug firmly and pull it straight out from the outlet.
- If the supply cord is damaged, it must be replaced by the manufacturer or its service agent or a similarly qualified person in order to avoid a hazard. Do not use a cord that shows cracks or abrasion damage along its length or at either the plug or connector end.
- Do not modify or extend the power cord length. It could cause electric shock or fire.
- When moving your refrigerator away from the wall, be careful not to roll over or damage the power cord.

- DO NOT store or use gasoline or other flammable vapors and liquids in the vicinity of this or any other appliance.
- DO NOT allow children to climb, stand, or hang on the refrigerator doors or shelves in the refrigerator. They could damage the refrigerator and seriously injure themselves.
- Keep fingers out of pinch point areas; clearances between the doors and cabinets are necessarily small. Be careful closing doors when children are in the area.
- Unplug your refrigerator before cleaning or making any repairs.
- If connected to a circuit protected by fuses, use time delay fuse.

**NOTE:** It is strongly recommended that any service be performed by a qualified technician.

## SAVE THESE INSTRUCTIONS

## ! WARNING

- Before replacing a burned-out or broken light bulb, unplug the refrigerator or turn off power at the circuit breaker or fuse box in order to avoid contact with a live wire filament. (A burned-out light bulb may break when being replaced, exposing the wire filament.)

**NOTE:** Some models have LED interior lighting and service should be performed by a qualified technician.

**WARNING:** Setting either or both controls to the OFF position does not remove power to the light circuit.

- When you are finished, reconnect the refrigerator to the electrical source and reset the controls (Thermostat, Refrigerator Control, and or Freezer Control, depending on the model) to the desired setting.
- This refrigerator must be properly installed in accordance with the **Attention Installer Instructions** that were taped to the front of the refrigerator.
- After your refrigerator is in operation, do not touch the cold surfaces in the freezer compartment when hands are damp or wet. Skin may adhere to the extremely cold surfaces.

- DO NOT touch the automatic ice making mechanism while the refrigerator is plugged in.
- DO NOT refreeze frozen foods which have thawed completely. The United States Department of Agriculture in Home and Garden Bulletin No. 69 says:

...You may safely refreeze frozen foods that have thawed if they still contain ice crystals or if they are still cold—below 39°F (4°C).

...Thawed ground meats, poultry or fish that have any off-odor or off-color should not be refrozen and should not be eaten. Thawed ice cream should be discarded. If the odor or color of any food is poor or questionable, dispose of it. The food may be dangerous to eat.

Even partial thawing and refreezing reduces the eating quality of foods, particularly fruits, vegetables and prepared foods. The eating quality of red meats is affected less than that of many other foods. Use refrozen foods as soon as possible to save as much of their quality as you can.

## SAVE THESE INSTRUCTIONS

## ! DANGER: RISK OF CHILD ENTRAPMENT

Junked or abandoned refrigerators are dangerous, even if they are sitting for only a few days. If you are getting rid of your old refrigerator, please follow the instructions at right to help prevent accidents (child entrapment and suffocation).

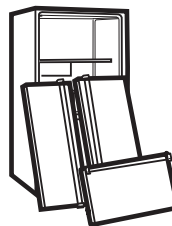

### BEFORE YOU THROW AWAY YOUR OLD REFRIGERATOR OR FREEZER:

- Take off the doors.
- Leave the shelves in place so that children may not easily climb inside.

## CFC/HCFC DISPOSAL

Your old refrigerator may have a cooling system that used CFCs or HCFCs (chlorofluorocarbons or hydrochlorofluorocarbons). CFCs and HCFCs are believed to harm stratospheric ozone if released to the atmosphere. Other refrigerants may also cause harm to the environment if released to the atmosphere.

If you are throwing away your old refrigerator, make sure the refrigerant is removed for proper disposal by a qualified technician. If you intentionally release refrigerant, you may be subject to fines and imprisonment under provisions of environmental legislation.

## ELECTRICAL & GROUNDING REQUIREMENTS

**IMPORTANT:** Please read carefully.  
**TO CONNECT ELECTRICITY**

### **⚠ WARNING**

#### **Electrical Shock Hazard**

**FOR PERSONAL SAFETY**, this appliance must be properly grounded. Have the wall outlet and the circuit checked by a qualified electrician to make sure the outlet is properly grounded.

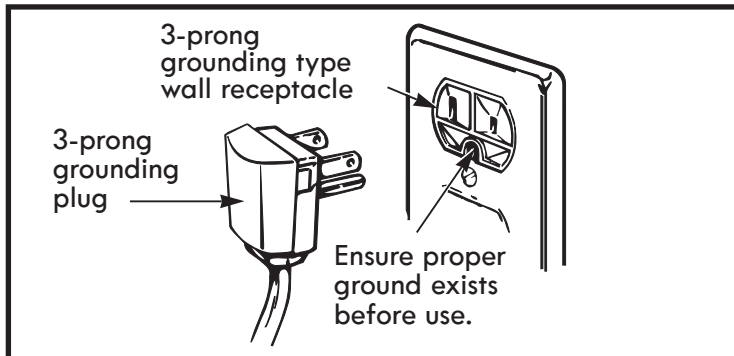

### **RECOMMENDED GROUNDING METHOD**

The refrigerator should always be plugged into its own individual properly grounded electrical outlet rated for 115 Volts, 60 Hz, AC only, and fused at 15 or 20 amperes. This provides the best performance and also prevents overloading house wiring circuits which could cause a fire hazard from overheated wires. It is recommended that a separate circuit serving only this appliance be provided.

Use a receptacle that cannot be turned off with a switch or pull chain. Do not use an extension cord.

Where a standard two-prong wall outlet is encountered, it is your personal responsibility and obligation to have it replaced with a properly grounded three-prong wall outlet.

### **USE OF EXTENSION CORDS**

**Because of potential safety hazards under certain conditions, the use of an extension cord is not recommended.** However, if you still elect to use an extension cord, it is absolutely necessary that it be a UL-listed (USA), 3-wire grounding type appliance extension cord having a grounding type plug and outlet, and that the electrical rating of the cord be 15 amperes (minimum) and 120 volts.

Use of an extension cord will increase the clearance needed for the back of the refrigerator.

# PARTS AND FEATURES

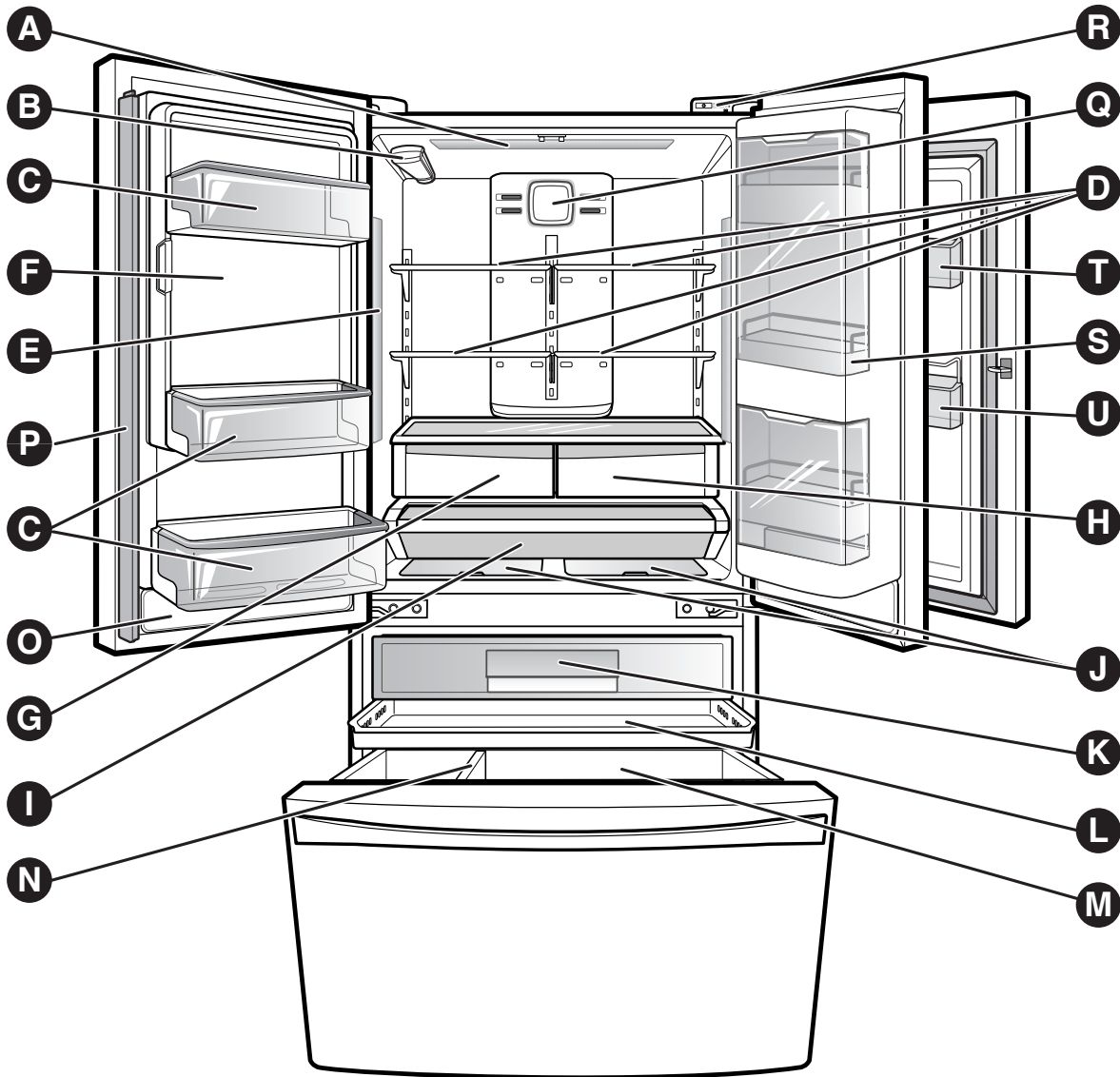

Use this page to become more familiar with the parts and features of your refrigerator.

**NOTE:** This guide covers several different models. The refrigerator you have purchased may have some or all of the items listed below. The locations of the features shown below may not match your model.

- A** Refrigerator Light
- B** Water Filter
- C** Fixed Door Bins
- D** Refrigerator Shelves
- E** Refrigerator Light (side)
- F** Ice Compartment (Icemaker and Ice Bin)
- G** Humidity Controlled Crisper
- H** Air Tight Crisper
- I** Temperature Controlled Pantry Drawer
- J** Convenience Bin
- K** Top Pullout Drawer
- L** Middle Pullout Drawer
- M** Durabase
- N** Durabase Divider
- O** Water Tank Cover
- P** Articulating Mullion
- Q** Air Filter
- R** Kenmore Connect Speaker
- S** Grab-N-Go Case
- T** Cheese & Butter Bin
- U** Condiment Bin

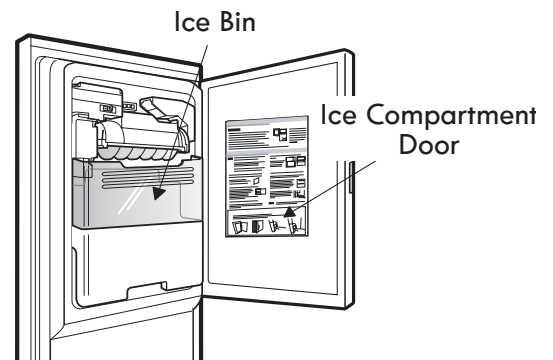



# REFRIGERATOR INSTALLATION

## **WARNING**

### **Excessive Weight Hazard:**

Use two or more people to move and install the refrigerator. Failure to do so can result in back or other injury.

## **WARNING**

### **Excessive Weight Hazard:**

Your refrigerator is heavy. When moving the refrigerator for cleaning or service, be sure to protect the floor. Always pull the refrigerator straight out when moving it. Do not wiggle or walk the refrigerator when trying to move it, as floor damage could occur.

## **UNPACKING YOUR REFRIGERATOR**

Remove tape and any temporary labels from your refrigerator before using. Do not remove any warning-type labels, the model and serial number label, or the Tech Sheet that is located under the front of the refrigerator.

To remove any remaining tape or glue, rub the area briskly with your thumb. Tape or glue residue can also be easily removed by rubbing a small amount of liquid dish soap over the adhesive with your fingers. Wipe with warm water and dry.

Do not use sharp instruments, rubbing alcohol, flammable fluids, or abrasive cleaners to remove tape or glue. These products can damage the surface of your refrigerator.

Refrigerator shelves are installed in the shipping position. Please reinstall shelves according to your individual storage needs.

## **WARNING**

### **Explosion Hazard:**

Keep flammable materials and vapors, such as gasoline, away from the refrigerator. Failure to do so can result in fire, explosion, or death.

## PRIOR TO USE

1. Clean your refrigerator thoroughly and wipe off all dust that accumulated during shipping.
2. Install accessories such as the ice cube bin, drawers, shelves, etc., in their proper places. They are packed together to prevent possible damage during shipment.
3. Allow your refrigerator to run for at least two to three hours before putting food in it. Check the flow of cold air in the freezer compartment to ensure proper cooling. Your refrigerator is now ready for use.

## INSTALLATION

The refrigerator should always be plugged into its own individual properly grounded electrical outlet rated for 115 Volts, 60 Hz, AC only, and fused at 15 or 20 amperes. This provides the best performance and also prevents overloading house wiring circuits which could cause a fire hazard from overheated wires. It is recommended that a separate circuit serving only this appliance be provided.

### **⚠ WARNING**

#### **Shock Hazard:**

To reduce the risk of electric shock, do not install the refrigerator in a wet or damp area.

## INSTALLATION (continued)

1. To avoid noise and vibration, the unit must be leveled and installed on a solidly constructed floor. If required, adjust the leveling legs to compensate for unevenness of the floor. The front should be slightly higher than the rear to aid in door closing. Leveling legs can be turned easily by tipping the cabinet slightly. Turn the leveling legs to the left to raise the unit or to the right to lower it. (See **LEVELING AND DOOR ALIGNMENT**.)

**NOTE:** Installing on carpeting, soft tile surfaces, a platform or weakly supported structure is not recommended.

2. Install this appliance in an area where the temperature is between 55°F (13°C) and 110°F (43°C). If the temperature around the appliance is too low or high, cooling ability may be adversely affected.

3. Select a place where a water supply can be easily connected for the automatic icemaker.

**NOTE:** The water pressure must be between 20 and 120 psi on models without a water filter and between 40 and 120 psi on models with a water filter.

4. Too small of a distance from adjacent items may result in lowered freezing capability and increased electricity consumption charges. Allow at least 24 inches (61 cm) in front of the refrigerator to open the doors and at least 2 inches (5.08 cm) between the back of the refrigerator and the wall.

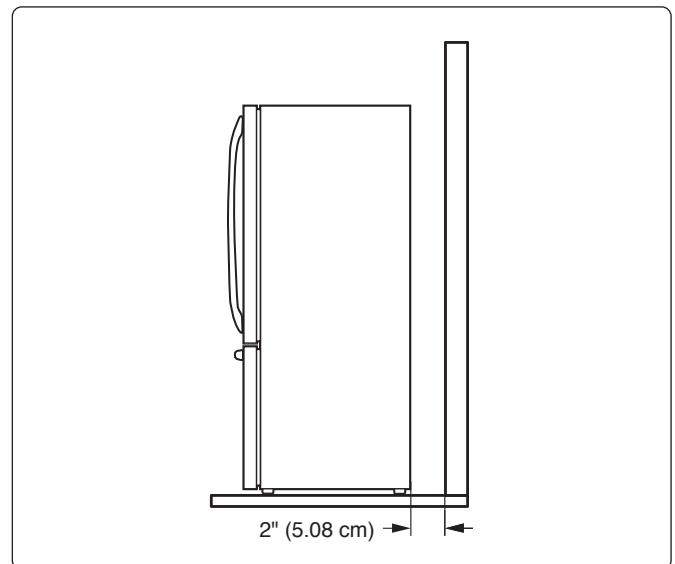

**NOTE:** Removing the doors is always recommended when it is necessary to move the refrigerator through a narrow opening. If it is necessary to remove the handles, follow the directions below.

## HOW TO REMOVE REFRIGERATOR DOOR HANDLES

**NOTE:** Handle appearance may vary from illustrations on this page.

### Removing Refrigerator Handles

Loosen the set screws with a  $\frac{3}{32}$  in. Allen wrench and remove the handle.

**NOTE:** If the handle mounting fasteners need to be tightened or removed, use a  $\frac{1}{4}$  in. Allen wrench.

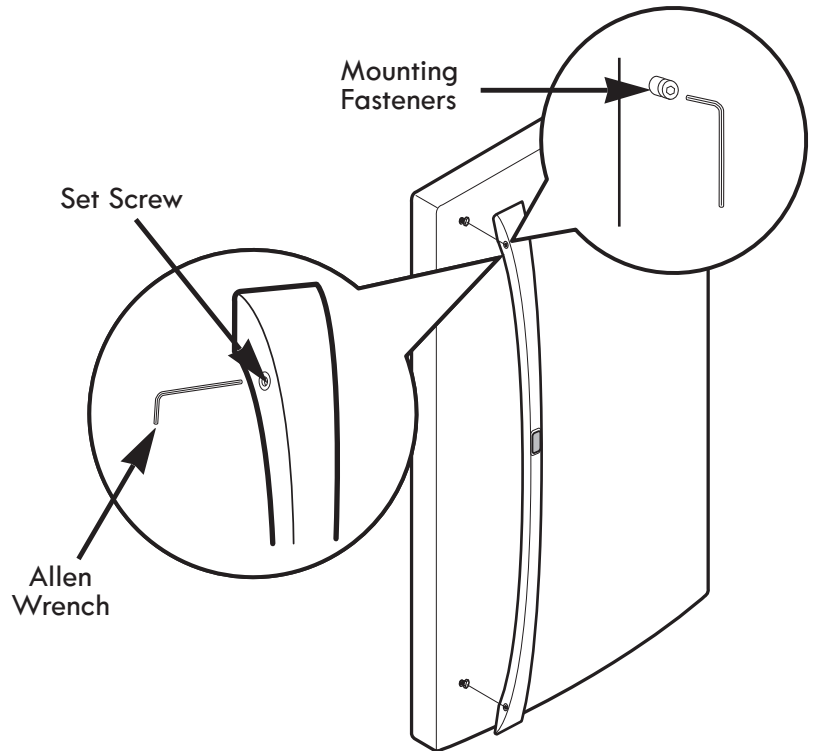

## HOW TO REPLACE REFRIGERATOR DOOR HANDLES

**NOTE:** Handle appearance may vary from illustrations on this page.

### Replacing Refrigerator Door Handles

Place the handle on the door by fitting the handle footprints over the mounting fasteners and tightening the set screws with a  $\frac{3}{32}$  in Allen wrench.

**NOTE:** If the handle mounting fasteners need to be tightened or removed, use a  $\frac{1}{4}$  in. Allen wrench.

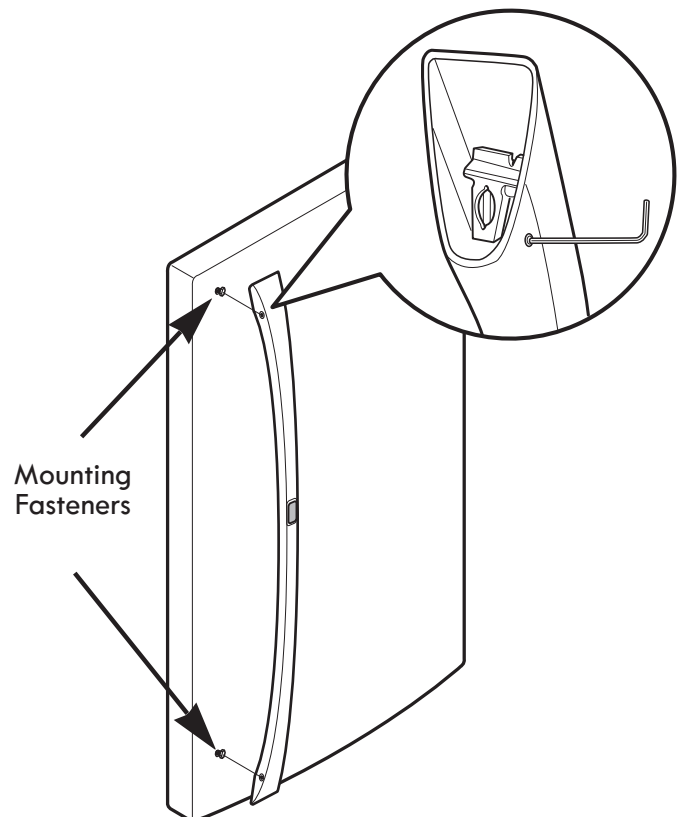

**NOTE:** Removing the doors is always recommended when it is necessary to move the refrigerator through a narrow opening. If it is necessary to remove the handles, follow the directions below.

### HOW TO REMOVE FREEZER DOOR HANDLE

**NOTE:** Handle appearance may vary from illustrations on this page.

#### Removing Freezer Drawer Handle

Loosen the set screws located on the lower side of the handle with a  $\frac{1}{8}$  in. Allen wrench and remove the handle.

**NOTE:** If the handle mounting fasteners need to be tightened or removed, use a  $\frac{1}{4}$  in. Allen wrench.

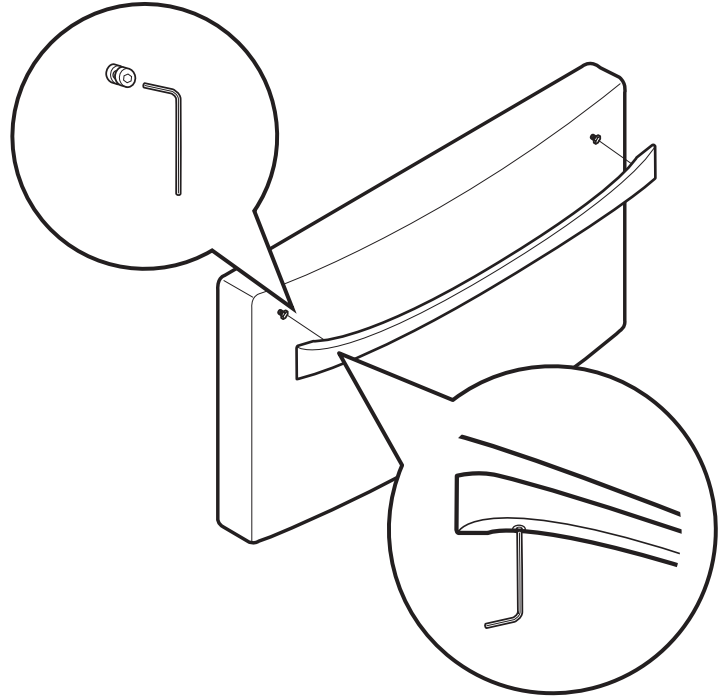

### HOW TO REPLACE FREEZER DOOR HANDLE

**NOTE:** Handle appearance may vary from illustrations on this page.

#### Replacing Freezer Drawer Handle

Place the handle on the door by fitting the handle footprints over the mounting fasteners and tightening the set screws with a  $\frac{1}{8}$  in. Allen wrench.

**NOTE:** If the handle mounting fasteners need to be tightened or removed, use a  $\frac{1}{4}$  in. Allen wrench.

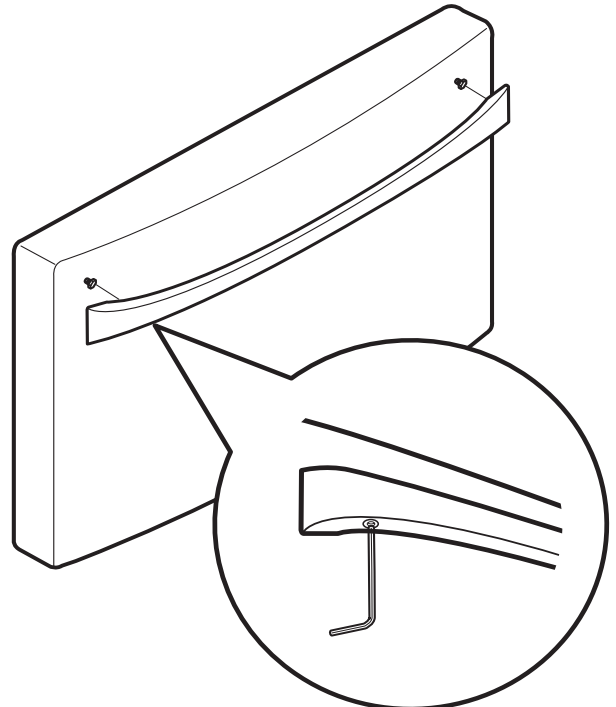

## **! WARNING**

When assembling or disassembling the handles:

- Grasp the handle firmly to ensure it will not drop or cause injury.
- Prevent the handle from swinging toward nearby people or animals.
- Insert the bracket hole of the handle into the stopper bolt of the door exactly, then assemble the set screws to fix the handle in place.
- Check for any gap between the door and handle after the handle is fixed in place.

## REMOVING AND REPLACING REFRIGERATOR DOORS

### ! WARNING

#### Excessive Weight Hazard:

Use two or more people to remove and install the refrigerator doors. Failure to do so can result in back or other injury.

### ! WARNING

#### Electrical Shock Hazard

- Disconnect the electrical supply to the refrigerator before installing. Failure to do so could result in serious injury or death.
- Do not put hands, feet or other objects into the air vents or bottom of the refrigerator. You may be injured or receive an electrical shock.

#### To remove the left refrigerator door:

On the back of the refrigerator, pull the water tube out of the collet fitting on the connector by pressing the fitting release ring (see picture below).

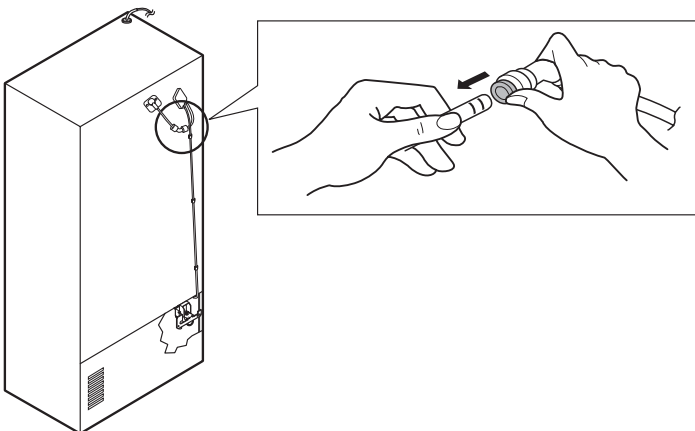

**! CAUTION:** Before you begin, remove food and bins from the doors.

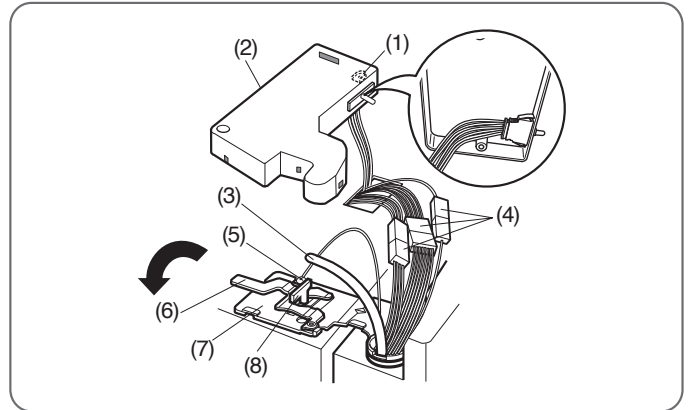

1. Open the door. Remove the top hinge cover screw (1). Lift up the cover (2).
2. Remove the cover.
3. Pull out the tube (3).
4. Disconnect all wire harnesses (4).
5. Remove the grounding screw (5).
6. Rotate hinge lever (6) counterclockwise. Lift the top hinge (7) free of the hinge lever latch (8).

**! CAUTION:** When lifting the hinge free of the latch, be careful that the door does not fall forward.

7. Lift the door from the middle hinge pin and remove the door.
8. Place the door, inside facing up, on a non-scratching surface.

#### To remove the right refrigerator door:

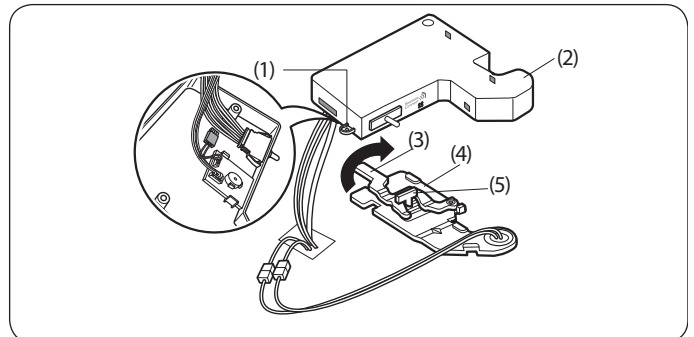

1. Open the door. Remove the top hinge cover screw (1). Lift up the cover (2).
2. Remove the cover.
3. Rotate the hinge lever (3) clockwise. Lift the top hinge (4) free of the hinge lever latch (5).

**! CAUTION:** When lifting the hinge free of the latch, be careful that the door does not fall forward.

4. Lift the door from the middle hinge pin and remove the door.
5. Place the door, inside facing up, on a non-scratching surface.

## Reinstalling the Refrigerator Door

### ► Left Door

1. Lower the door onto the middle hinge pin (10).
2. Fit the top hinge (7) over the hinge lever latch (8) and into place. Rotate the lever (6) clockwise to secure the hinge.
3. Install the grounding screw (5) and connect the two wire harnesses (4).
4. Push the water tube (3) located at the top of the left door into the hole beside the left hinge on the top of the cabinet until it exits through the back.
5. Insert the water supply tube (3) into the connector until you see only one scale mark. Fully insert the tube over  $\frac{5}{8}$  in. (15 mm).
6. Hook the tabs on the left side of the hinge cover (1) under the edge of the top hinge (7) and position the cover in place. Insert and tighten the cover screw (1).

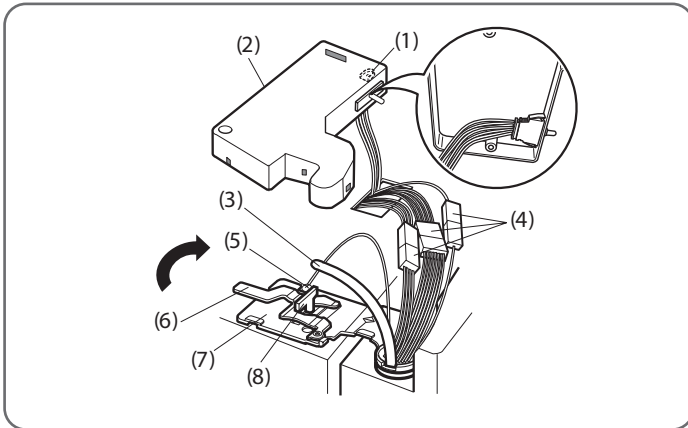

### ► Right Door

1. Lower the door onto the middle hinge pin (9).
2. Fit the top hinge (4) over the hinge lever latch (5) and into place. Rotate the lever (3) counterclockwise to secure the hinge.
3. Hook the tabs on the right side of the hinge cover (2) under the edge of the top hinge (4) and position the cover in place. Insert and tighten the cover screw (1).

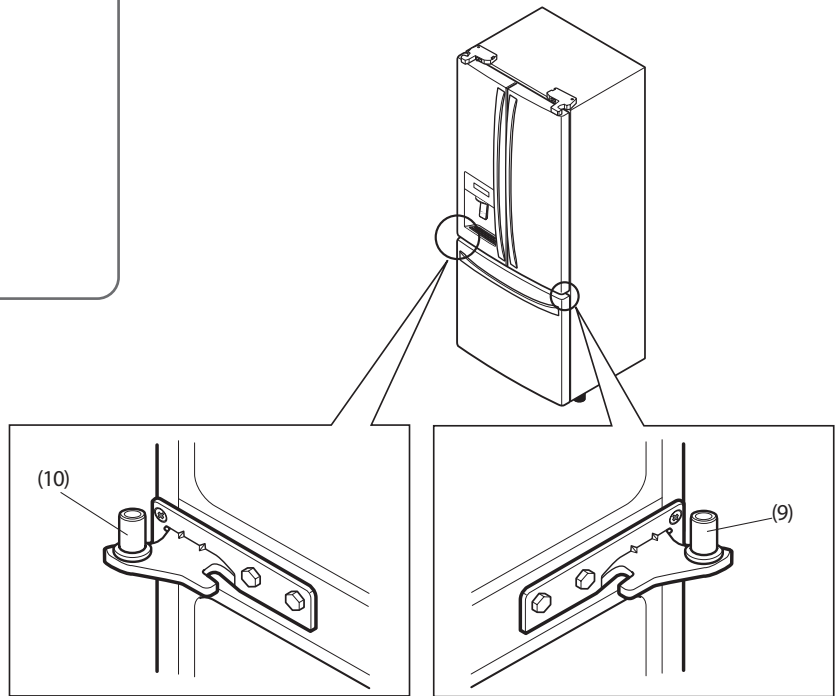
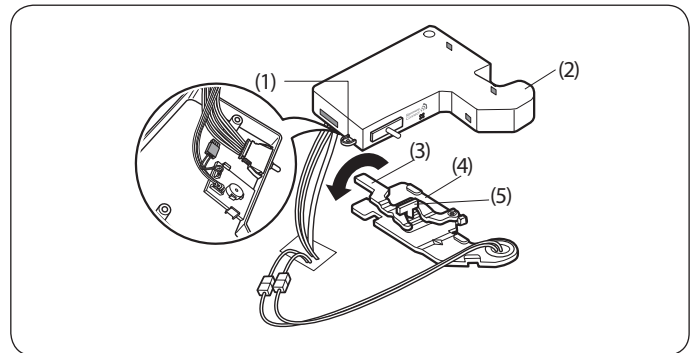

## ⚠ CAUTION

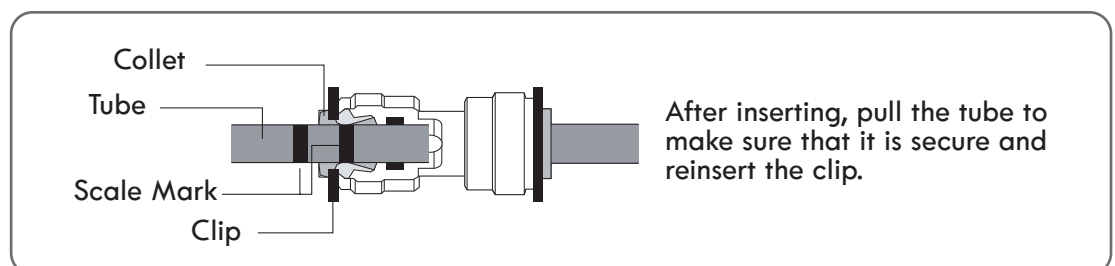

## HOW TO REMOVE THE FREEZER DRAWER

**⚠ WARNING:** Use two or more people to remove and install the freezer drawer. Failure to do so can result in back or other injury.

**⚠ CAUTION:** Do not hold the handle when removing or replacing the drawer. The handle may come off and it could cause personal injury.

**NOTE:** In the following figures, the Pullout Drawer located above the freezer drawer is not shown for clarity.

Pull the drawer open to full extension. Remove the lower basket ① by lifting the basket from the rail system.

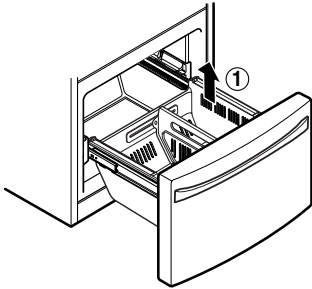

Remove the screws ②, ②-1 from the rail on both sides.

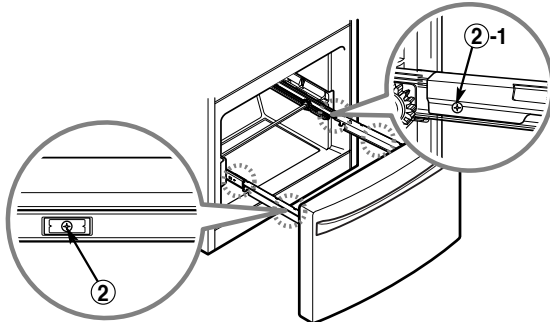

Grasp the drawer on each side and pull it up to separate it from the rails.

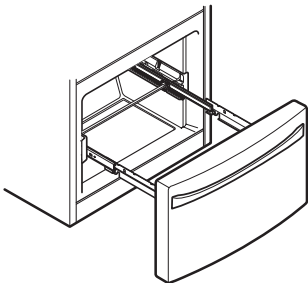

Using both hands, slide the bars in simultaneously.

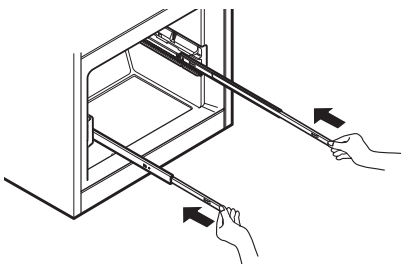

## HOW TO INSTALL THE FREEZER DRAWER

Pull out each rail to full extension.

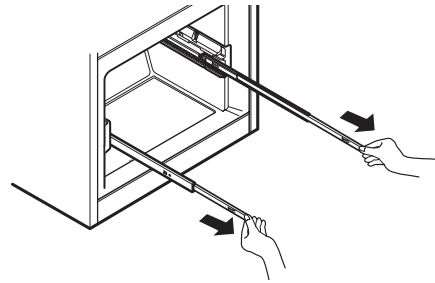

Grasp the drawer on each side and hook the drawer supports ① into the rail tabs ② located on both sides.

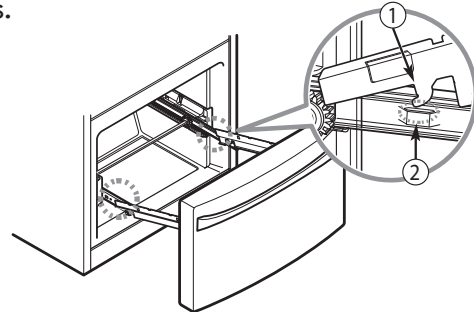

Lower the door into its final position and tighten the screws ③, ③-1 located on both sides.

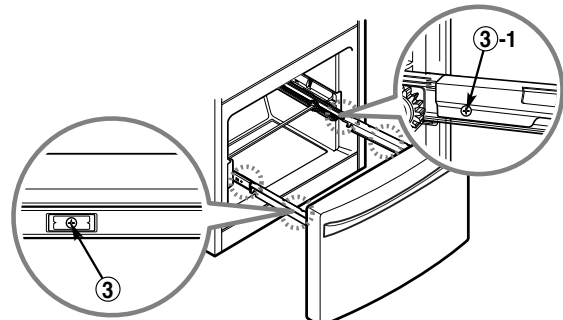

With the drawer pulled out to full extension, insert the lower basket ④ in the rail assembly.

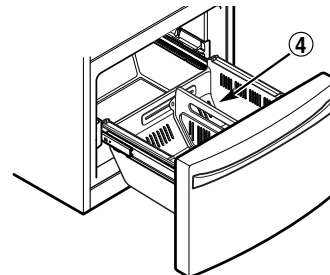

**⚠ WARNING:** If the Durabase divider is removed, there is enough open space for children or pets to crawl inside. To prevent accidental child and pet entrapment or suffocation risk, DO NOT allow them to touch or go near the freezer drawer.

**⚠ WARNING:** DO NOT step or sit down on the freezer drawer.

## LEVELING AND DOOR ALIGNMENT

### Leveling

After installing, plug the refrigerator's power cord into a 3-prong grounded outlet and push the refrigerator into the final position.

Your refrigerator has two front leveling legs—one on the right and one on the left. Adjust the legs to alter the tilt from front-to-back or side-to-side. If your refrigerator seems unsteady, or you want the doors to close more easily, adjust the refrigerator's tilt using the instructions below:

**NOTE:** Tools Required:  $1\frac{1}{16}$ " wrench or flat blade screwdriver.

1. Turn the leveling leg to the left to raise that side of the refrigerator or to the right to lower it. It may take several turns of the leveling leg to adjust the tilt of the refrigerator.

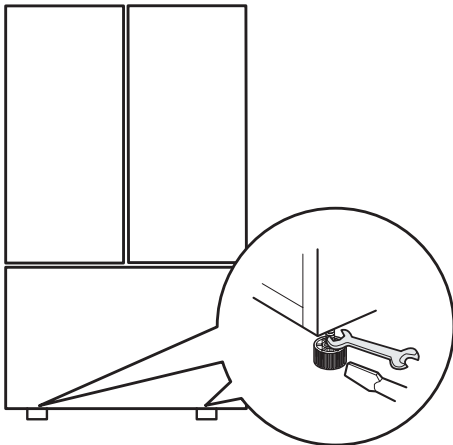

**NOTE:** Having someone push backward against the top of the refrigerator takes some weight off of the leveling legs. This makes it easier to adjust the legs.

2. Open both doors again and check to make sure that they close easily. If the doors do not close easily, tilt the refrigerator slightly more to the rear by turning both leveling legs to the left. It may take several more turns, and you should turn both leveling legs the same amount.

**NOTE:** Your refrigerator is uniquely designed with two fresh food doors. Either door can be opened or closed independently of the other. You may have to exert slight pressure on the doors to get them to close completely.

### Door Alignment

The left refrigerator door has an adjustable nut, located on the bottom hinge, to raise and lower the door for proper alignment.

If the space between your doors is uneven, follow the instructions below to align the doors evenly:

Use the wrench (included with the Use & Care Guide) to turn the nut in the door hinge to adjust the height. To the right to raise or to the left to lower the height.

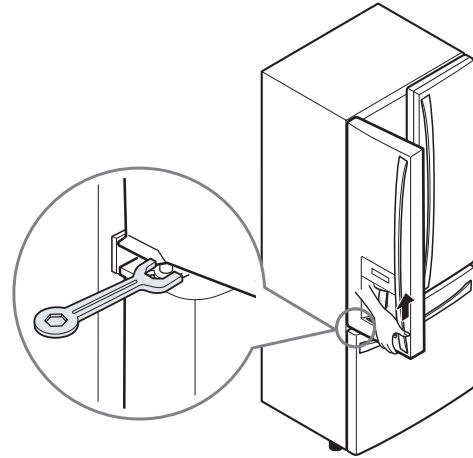

**The right refrigerator door does not have an adjustable nut.**

**If the space between your doors is uneven, follow the instructions below to align the right door:**

1. With one hand, lift up the door to raise it at the middle hinge.
2. With the other hand, use pliers to insert the snap ring as shown.
3. Insert additional snap rings until the right door is aligned. (Three snap rings are provided with the unit.)

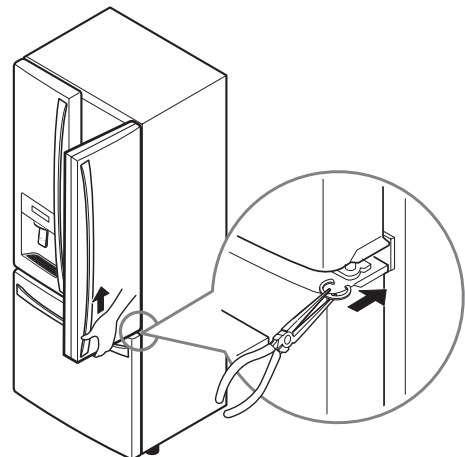



# USING YOUR REFRIGERATOR

## SETTING THE CONTROLS

### AIRFLOW

Be sure not to block vents while packing your refrigerator. Doing so will restrict airflow and may cause the refrigerator temperature to become too warm or cause interior moisture buildup. (See the air flow diagram below.)

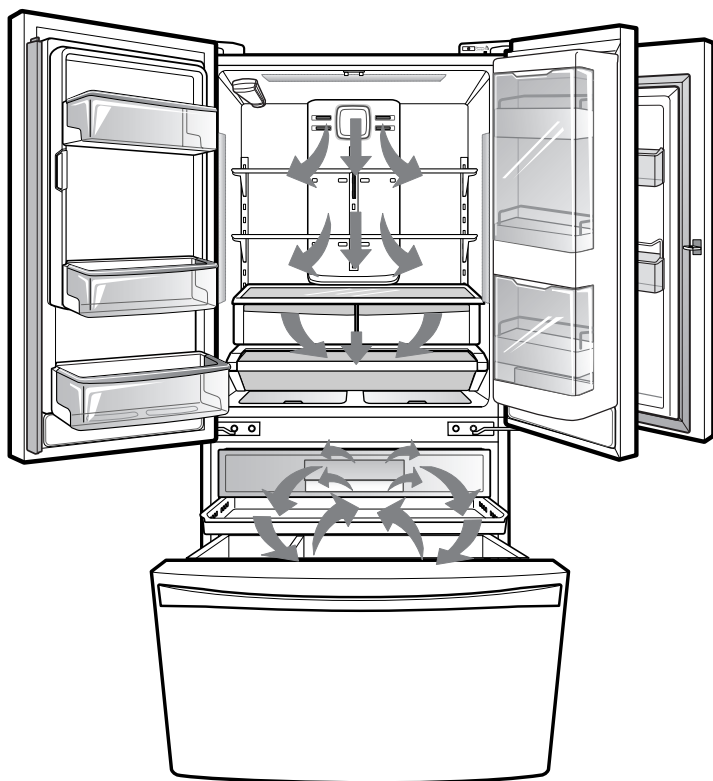

### Temperature

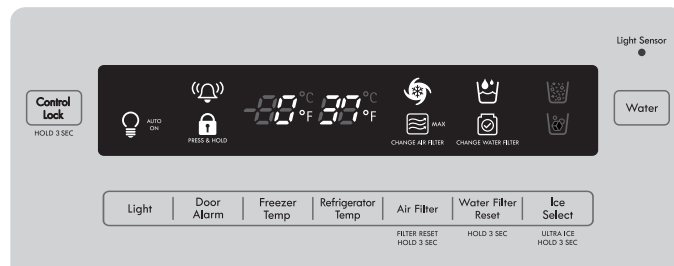

- The Refrigerator Temp Control ranges from 33°F to 46°F (0°C to 8°C). Press the Refrigerator Temp button to cycle through the available temperature settings one increment at a time.
- The Freezer Temp Control range is from -6°F to 8°F (-21°C to -13°C). Press the Freezer Temp button to cycle through the available temperature settings one increment at a time.

**NOTE:** When changing control settings, wait 24 hours before making additional adjustments. The controls are set correctly when milk or juice is as cold as you would like and when ice cream is firm. If the temperature in either compartment is too cold or too warm, change the setting one increment at a time. Wait 24 hours for the change to stabilize before adjusting again.

**NOTE:** The Cheese & Butter and Condiment bins are not recommended for storing items that spoil easily such as milk and mayonnaise.

### Dispenser

- When you press the Water button, the Water icon will illuminate.
- When you press the Ice Select button, either the cube or crushed ice icon will illuminate.
- Some dripping may occur after dispensing. Hold your cup beneath the dispenser for a few seconds after dispensing to catch all of the drops.



**NOTE:** The dispenser will not work if any door is left open or if the control lock is engaged.

**CAUTION:** The control display is operated by touch. Excessive moisture on the display may cause a malfunction. Please keep the display clean and dry.

## USING YOUR REFRIGERATOR

### Air Filter MAX

CHANGE AIR FILTER

The Air Filter helps remove odors from the refrigerator. The Air Filter has two settings, Auto and MAX. In Auto mode, the Air Filter will cycle on and off in increments of ten minutes on and one hundred and ten minutes off. If set to the MAX mode, the Air Filter will stay on continuously for four hours, cycling on and off in increments of ten minutes on and five minutes off. After four hours, the Air Filter will switch to Auto mode.

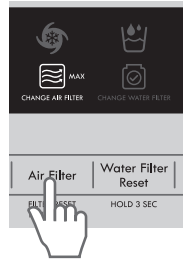

- Auto mode is the default mode.
- Press the Air Filter button once for MAX mode 

### Air Filter Reset MAX

CHANGE AIR FILTER

When the CHANGE AIR FILTER icon turns on, the air filter needs to be replaced. After replacing the air filter, press and hold the Air Filter button for three seconds to turn the icon light off. It is recommended to change the air filter approximately every 6 months.

### Ultra Ice

- When you press and hold the Ice Select button, the Ultra Ice graphic will illuminate in the display and will continue for 24 hours. The function will automatically shut off after 24 hours.
- You can stop this function manually by touching the button one more time.
- This function increases both ice making and freezing capabilities.

### Water Filter Reset

CHANGE WATER FILTER

When the water filter indicator turns on, you need to change the water filter. After changing the water filter, press and hold the Water Filter Reset button for three seconds to turn the indicator light off. You need to change the water filter approximately every six months.

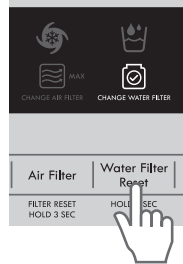

### Accent Light/Light Sensor

This light has three settings: On, Off and Auto. If the light is set to the Auto mode, the Accent Light will automatically turn on and off according to the brightness of the room, as detected by the light sensor.

### Articulating Mullion

This feature is a metal strip attached to the left door that articulates (rotates) 90 degrees as the door is closed, forming a mullion (base) for the left and right door gaskets to seal against.

### CAUTION

To reduce the risk of scratching the door or breaking the door mullion, please make sure that the refrigerator door mullion is always folded in.

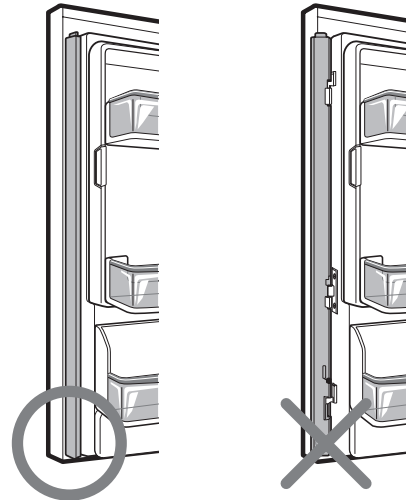

### Door Alarm

- When power is connected to the refrigerator, the door alarm is initially set to ON. When you press the **Door Alarm** button, the display will change to OFF and the **Door Alarm** function will deactivate.
- When either the refrigerator or the freezer door is left open for more than 60 seconds, the alarm tone will sound to let you know that the door is open.
- When you close the door, the door alarm will stop.

### Control Lock PRESS & HOLD

- When power is initially connected to the refrigerator, the **Lock** function is off.
- If you want to activate the **Lock** function to lock other buttons, press and hold the **Control Lock** button for three seconds or more. The **Control Lock** icon will display and the **Lock** function is now enabled.
- When the **Lock** function is activated, no other buttons will work. The dispenser pad is also deactivated.
- To disable the **Lock** function, press and hold the **Control Lock** button for approximately three seconds.

### Temperature Mode Switch Function (°F <->°C)

If you want to convert °F to °C or vice versa, press and hold the **Freezer Temp** and **Refrigerator Temp** buttons at the same time for approximately five seconds.

### Demo Mode (For Store Use Only)

The **Demo Mode** disables all cooling in the refrigerator and freezer sections to conserve energy while on display in a retail store. When activated, OFF will display on the control panel.



### To deactivate:

With either refrigerator door opened, press and hold the **Refrigerator Temp** and **Ultra Ice** buttons at the same time for five seconds. The control panel will beep and the temperature settings will display to confirm that **Demo Mode** is deactivated. Use the same procedure to activate the **Demo Mode**.

## IN-DOOR ICE BIN

### ⚠ CAUTION

Keep hands and tools out of the ice compartment door and dispenser chute. Failure to do so may result in damage or personal injury.

The icemaker will stop producing ice when the in-door ice bin is full. If you need more ice, empty the ice bin into the extra ice bin in the freezer compartment. During use, the ice can become uneven causing the icemaker to misread the amount of ice cubes and stop producing ice. Shaking the ice bin to level the ice within it can reduce this problem.

**NOTE:** Storing cans or other items in the ice bin will damage the icemaker.

Keep the ice compartment door closed tightly. If the ice compartment door is not closed tightly, the cold air in the ice bin will freeze food in the refrigerator compartment. This could also cause the icemaker to stop producing ice.

**NOTE:** If the ON/OFF switch on the icemaker is set to OFF for an extended period of time, it is recommended to empty the ice bin.

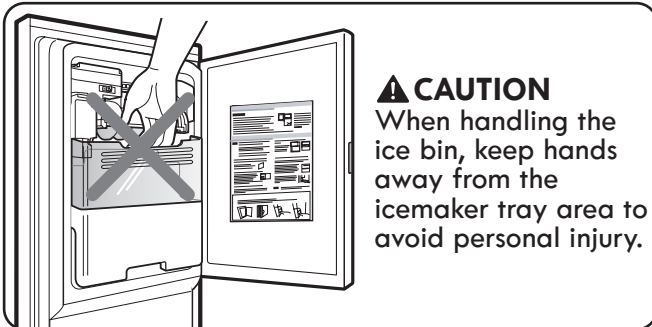

1. Pull or push the door handle to open or close the ice compartment.

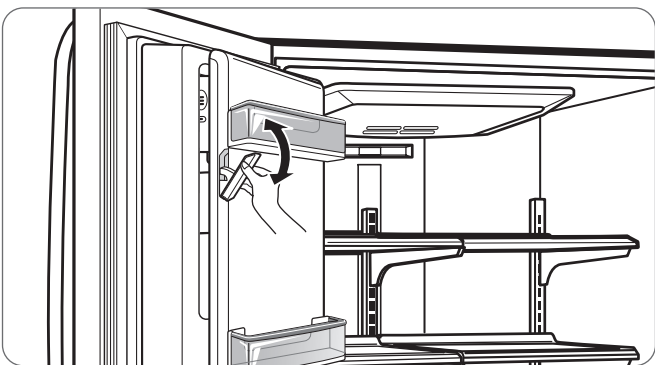

2. To remove the in-door ice bin, grip the front handle, slightly lift the lower part, and slowly pull out the bin as shown.

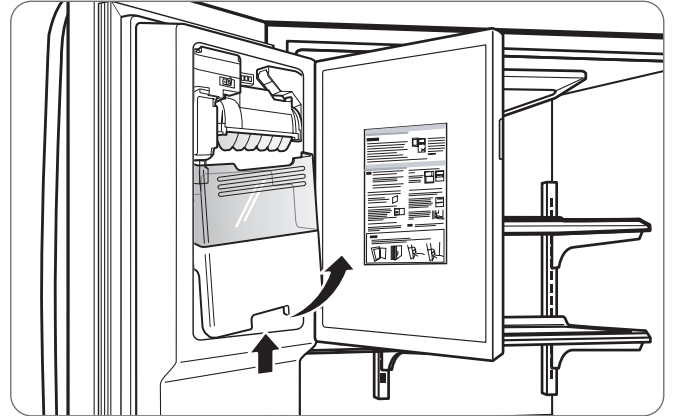

3. To reinstall the in-door ice bin, slightly slant the bin during replacement to avoid contact with the icemaker.

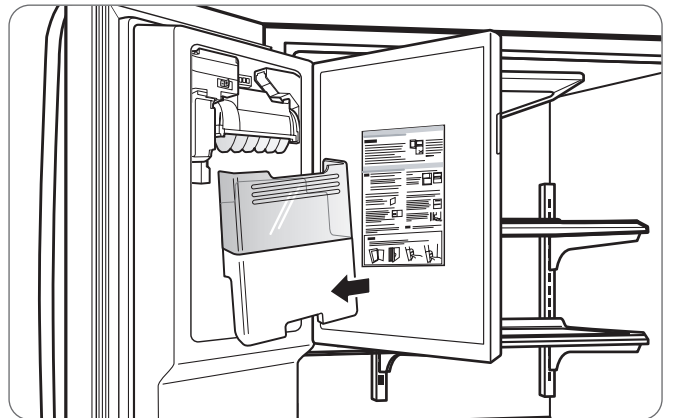

4. Avoid touching the ice-detecting sensor when replacing the ice bin. See the label on the ice compartment door for details.

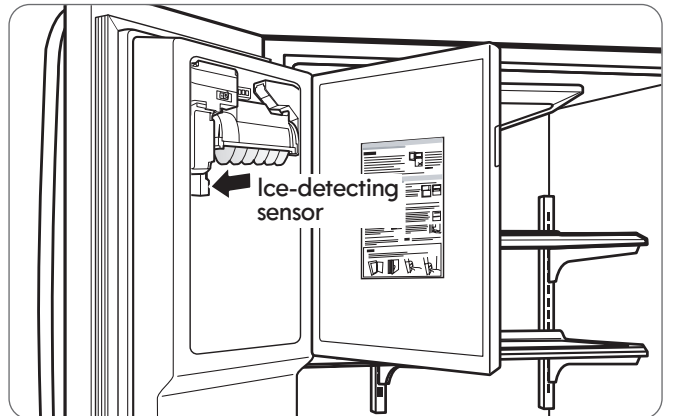

## AUTOMATIC ICEMAKER

Ice is made in the automatic icemaker and sent to the dispenser. The icemaker will produce 70~210 cubes in a 24-hour period, depending on freezer compartment temperature, room temperature, number of door openings and other operating conditions.

- It takes about 12 to 24 hours for a newly installed refrigerator to begin making ice. Wait 72 hours for full ice production to occur.
- Ice making stops when the in-door ice bin is full. When full, the in-door ice bin holds approximately 6 to 8 (12-16 oz) glasses of ice.
- To turn off the automatic icemaker, set the icemaker switch to **OFF (O)**. To turn on the automatic icemaker, set the switch to **ON (I)**.
- The water pressure must be between 20 and 120 psi on models without a water filter and between 40 and 120 psi on models with a water filter to produce the normal amount and size of ice cubes.
- Foreign substances or frost on the ice-detecting sensor can interrupt ice production. Make sure the sensor area is clean at all times for proper operation.

## WARNING

### Personal Injury Hazard

DO NOT place fingers or hands on the automatic ice making mechanism while the refrigerator is plugged in.

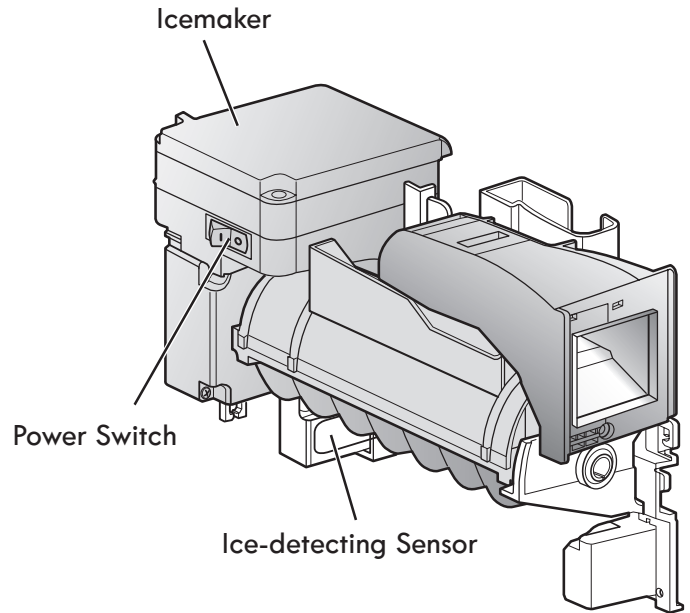

### AUTOMATIC ICEMAKER (continued)

#### ⚠ CAUTION

- The first ice and water dispensed may include particles or odor from the water supply line or the water tank.
- Throw away the first few batches of ice. This is also necessary if the refrigerator has not been used for a long time.
- Never store beverage cans or other items in the ice bin for the purpose of rapid cooling. Doing so may damage the icemaker or the containers may burst.
- If discolored ice is dispensed, check the water filter and water supply. If the problem continues, contact a Sears or other qualified service center. Do not use the ice or water until the problem is corrected.
- Keep children away from the dispenser. Children may play with or damage the controls.
- The ice passage may become blocked with frost if only crushed ice is used. Remove the frost that accumulates by removing the ice bin and clearing the passage with a rubber spatula. Dispensing cubed ice can also help prevent frost buildup.
- Never use thin crystal glass or crockery to collect ice. Such containers may chip or break resulting in glass fragments in the ice.
- Dispense ice into a glass before filling it with water or other beverages. Splashing may occur if ice is dispensed into a glass that already contains liquid.
- Never use a glass that is exceptionally narrow or deep. Ice may jam in the ice passage and refrigerator performance may be affected.
- Keep the glass at a proper distance from the ice outlet. A glass held too close to the outlet may prevent ice from dispensing.
- To avoid personal injury, keep hands out of the ice door and passage.
- Never remove the dispenser cover.
- If ice or water dispenses unexpectedly, turn off the water supply and contact Sears Home Service at 1-800-4-MY HOME®.

#### WHEN YOU SHOULD SET THE ICEMAKER POWER SWITCH TO OFF (O)

- When the water supply will be shut off for several hours.
- When the ice bin is removed for more than one or two minutes.
- When the refrigerator will not be used for several days.

**NOTE:** The ice bin should be emptied when the icemaker ON/OFF switch is turned to the **OFF** position.

#### NORMAL SOUNDS YOU MAY HEAR

- The icemaker water valve will buzz as the icemaker fills with water. If the power switch is in the **ON (I)** position, it will buzz even if it has not yet been hooked up to water. To stop the buzzing, move the power switch to **OFF (O)**.  
**NOTE:** Keeping the power switch in the **ON (I)** position before the water line is connected can damage the icemaker.
- You will hear the sound of cubes dropping into the bin and water running in the pipes as the icemaker refills.

#### PREPARING FOR VACATION

Set the icemaker power switch to **OFF (O)** and shut off the water supply to the refrigerator.

**NOTE:** The ice bin should be emptied anytime the icemaker ON/OFF switch is turned to the **OFF (O)** position.

If the ambient temperature will drop below freezing, have a qualified technician drain the water supply system to prevent serious property damage due to flooding caused by ruptured water lines or connections.

**FOOD STORAGE GUIDE**

Wrap or store food in the refrigerator in airtight and moisture-proof material unless otherwise noted. This prevents food odor and taste transfer throughout the refrigerator. For dated products, check date code to ensure freshness.

| Items   | How to   |
|---|--|
| <b>Butter or margarine</b>                      | ▶ Keep opened butter in a covered dish or closed compartment. When storing an extra supply, wrap in freezer packaging and freeze.  |
| <b>Cheese</b>                                   | ▶ Store in the original wrapping until you are ready to use it. Once opened, rewrap tightly in plastic wrap or aluminum foil.  |
| <b>Milk</b>                                     | ▶ Wipe milk cartons. For best storage, place milk on interior shelf, not on door shelf.  |
| <b>Eggs</b>                                     | ▶ Store in original carton on interior shelf, not on door shelf.   |
| <b>Fruit</b>                                    | ▶ Do not wash or hull the fruit until it is ready to be used. Sort and keep fruit in its original container, in a crisper, or store in a completely closed paper bag on a refrigerator shelf.  |
| <b>Leafy vegetables</b>                         | ▶ Remove store wrapping and trim or tear off bruised and discolored areas. Wash in cold water and drain. Place in plastic bag or plastic container and store in crisper.                       |
| <b>Vegetables with skins (carrots, peppers)</b> | ▶ Place in plastic bags or plastic container and store in crisper.   |
| <b>Fish</b>                                     | ▶ Store fresh fish and shellfish in the freezer section if they are not being consumed the same day of purchase. It is recommended to consume fresh fish and shellfish the same day purchased. |
| <b>Leftovers</b>                                | ▶ Cover leftovers with plastic wrap, aluminum foil, or plastic containers with tight lids.   |

**STORING FROZEN FOOD**

**NOTE:** Check a freezer guide or a reliable cookbook for further information about preparing food for freezing or food storage times.

**Freezing**

Your freezer will not quick-freeze a large quantity of food. Do not put more unfrozen food into the freezer than will freeze within 24 hours (no more than 2 to 3 lbs. of food per cubic foot of freezer space). Leave enough space in the freezer for air to circulate around packages. Be careful to leave enough room at the front so the door can close tightly.

Storage times will vary according to the quality and type of food, the type of packaging or wrap used (how airtight and moisture-proof) and the storage temperature. Ice crystals inside a sealed package are normal. This simply means that moisture in the food and air inside the package have condensed, creating ice crystals.

**NOTE:** Allow hot foods to cool at room temperature for 30 minutes, then package and freeze. Cooling hot foods before freezing saves energy.

**Packaging**

Successful freezing depends on correct packaging. When you close and seal the package, it must not allow air or moisture in or out. If it does, you could have food odor and taste transfer throughout the refrigerator and could also dry out frozen food.

**Packaging recommendations:**

- Rigid plastic containers with tight-fitting lids
- Straight-sided canning/freezing jars
- Heavy-duty aluminum foil
- Plastic-coated paper
- Non-permeable plastic wraps
- Specified freezer-grade self-sealing plastic bags

Follow package or container instructions for proper freezing methods.

**Do not use**

- Bread wrappers
- Non-polyethylene plastic containers
- Containers without tight lids
- Wax paper or wax-coated freezer wrap
- Thin, semi-permeable wrap

**⚠ CAUTION:** Do not keep beverage cans or plastic food containers in the freezer compartment. They may break or burst if they freeze.

### REFRIGERATOR SECTION

#### WATER DISPENSER

To dispense cold water, push on the dispenser switch with a glass.

**NOTE:** The dispenser is equipped with a light that turns on when the dispenser pad is engaged.

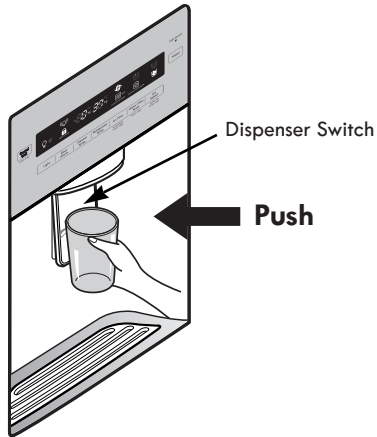

Some dripping may occur after dispensing. Hold your cup beneath the dispenser for a few seconds after dispensing to catch all of the drops.

**⚠ WARNING:** Do not put your fingers up the ice chute opening. Doing so can result in severe injury.

**⚠ CAUTION:** Do not dispense ice into fine china or crystal glasses. China or crystal can break.

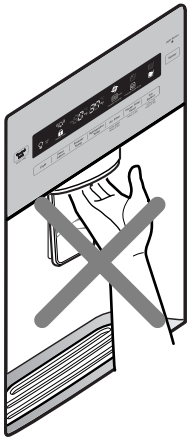

#### WATER TRAY

Press down on either of the front corners to remove the tray.

**NOTE:** There is no drain beneath the tray. You may need to empty the tray of any liquid that collects in it.

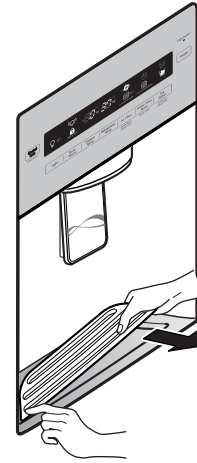



**REFRIGERATOR SHELVES**

The shelves in your refrigerator are adjustable to meet your individual storage needs. Your model may have glass or wire shelves.

Adjusting the shelves to fit different heights of items will make finding the exact item you want easier. Doing so will also reduce the amount of time the refrigerator door is open which will save energy.

**IMPORTANT:** Do not clean glass shelves with warm water while they are cold. Shelves may break if exposed to sudden temperature changes or impact.

**⚠ CAUTION:** Glass shelves are heavy. Use special care when removing them.

**Adjusting Shelves (Cantilever)**

Remove shelves from the shipping position and replace shelves in the position you want.

**To remove a shelf**—Tilt up the front of the shelf in the direction of ① and lift it in the direction of ②. Pull the shelf out.

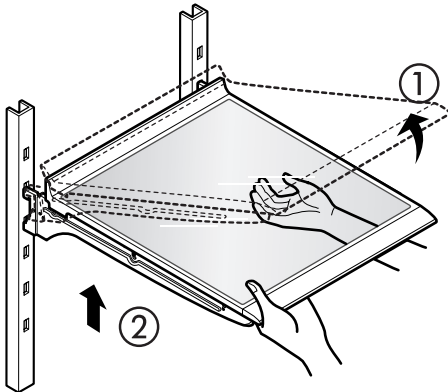

**To reinstall a shelf**—Tilt the front of the shelf up and guide the shelf hooks into the slots at a desired height. Then, lower the front of the shelf so that the hooks drop into the slots.

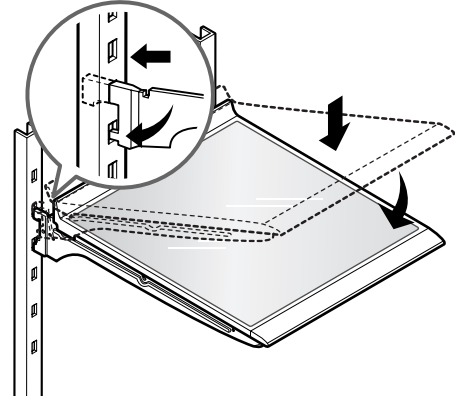

**⚠ CAUTION:** Make sure that shelves are level from one side to the other. Failure to do so may result in the shelf falling or spilling food.

**Folding Shelf (on some models)**

You can store taller items, such as a gallon container or bottles, by simply pushing the front half of the shelf underneath the back half of the shelf. Pull the front of the shelf toward you to return to a full shelf.

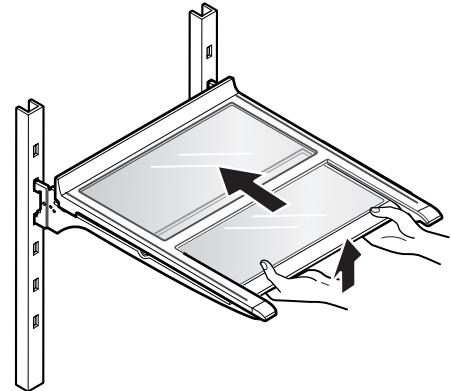

## HUMIDITY CONTROLLED CRISPER

The crispers provide fresher tasting fruit and vegetables by letting you easily control humidity inside the drawer.

You can control the amount of humidity in the moisture-sealed crispers by adjusting the control to any setting between **VEGETABLES** and **FRUIT**.

- **VEGETABLES** keeps moist air in the crisper for best storage of fresh, leafy vegetables.
- **FRUIT** lets moist air out of the crisper for best storage of fruit.

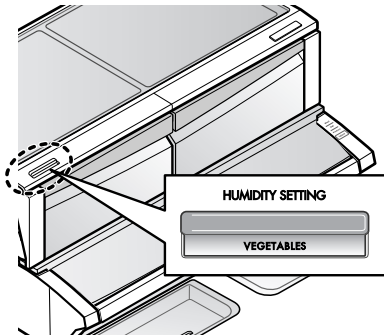

## REMOVING THE HUMIDITY CONTROLLED CRISPER

1. To remove, pull the drawer out to full extension.
2. Lift the front of the crisper up, then pull it straight out.

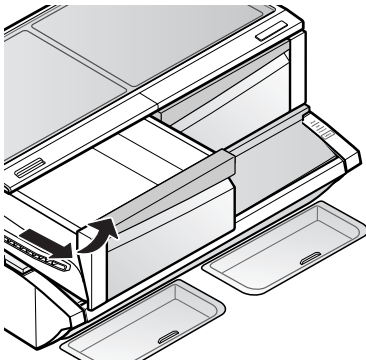

3. To install, slightly tilt up the front, insert the drawer into the frame and push it back into place.

### To remove the glass

1. Lift up the glass under the crisper cover.
2. Pull the glass up and out.

**NOTE:** Pantry drawer not shown for clarity.

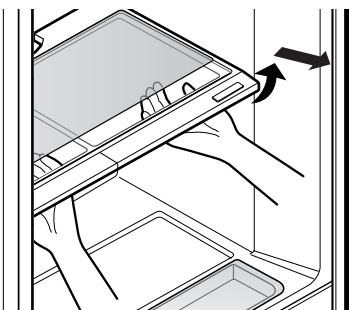

## CONVENIENCE BIN

Open and close by pulling the handle of the lid.

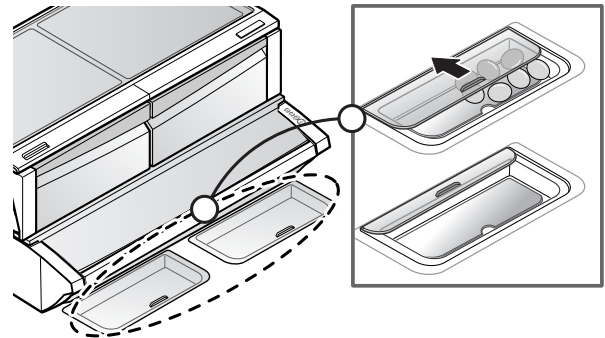

## REMOVING THE CONVENIENCE BIN LID

1. Open the lid about half way ①.
2. Lift the lid up and pull out ②.

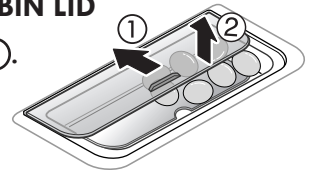

## REMOVING THE CONVENIENCE BIN BOTTOM COVER

1. Open the lid.
2. Pull the bottom cover out ②.

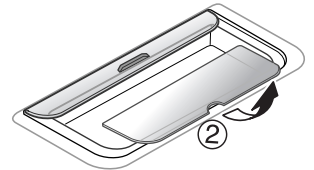

## TEMPERATURE CONTROLLED PANTRY DRAWER

The **Temperature Controlled Pantry Drawer** provides storage space with a variable temperature control that can keep the compartment at a slightly different temperature than the refrigerator section. This drawer can be used for large party trays, deli items and beverages. (This drawer should not be used for vegetables that require high humidity.)

Press the button to choose between Produce (Cold), Deli (Colder) and Meat (Coldest).

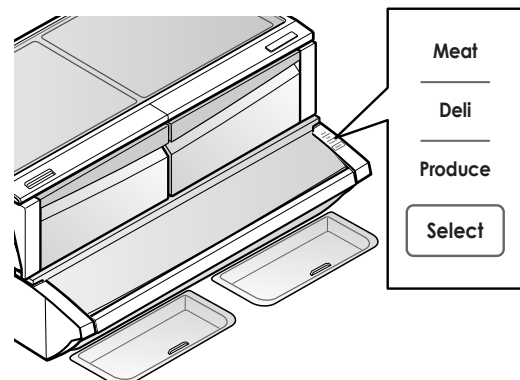

### GRAB-N-GO

The Grab-N-Go compartment allows for easy access to commonly used food items.

The inner Grab-N-Go door includes two door bins, the Cheese & Butter and Condiment bins, that are specially designed for food that can be stored at a warmer temperature. This makes spreading butter and slicing cheese easier.

**NOTE:** The Cheese & Butter and Condiment bins are not recommended for storing items that spoil easily such as milk and mayonnaise.

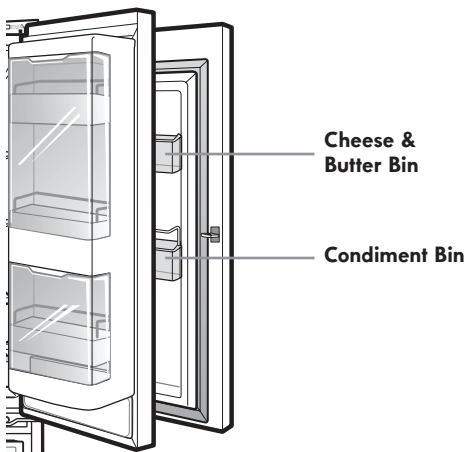

### GRAB-N-GO COMPARTMENT

To access the Grab-N-Go compartment, lightly press the button on the right refrigerator door handle to open the door.

There is no need to grip the handle when opening the Grab-N-Go door. If the handle is gripped when the button is pressed you may hear a clicking noise. This is normal.

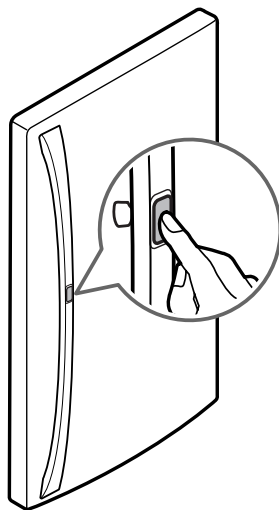

### GRAB-N-GO CASE

To open the Grab-N-Go case, slightly push the marked area to pop it open. The Grab-N-Go Case is removable for easy cleaning and adjustment.

1. To remove the Grab-N-Go case, lift up and pull out.
2. To replace the Grab-N-Go case, line up the tabs on the Grab-N-Go Case with the slots on the door and push down until it snaps into place.

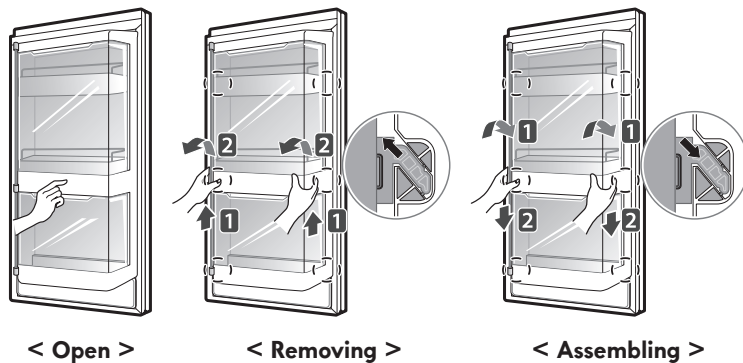

### GRAB-N-GO DOOR BINS

The Grab-N-Go inner and outer door bins are removable for easy cleaning.

1. To remove the door bins, lift up and pull out.
2. To replace the door bins, slide the door bin in above the desired support and push down until it snaps into place.

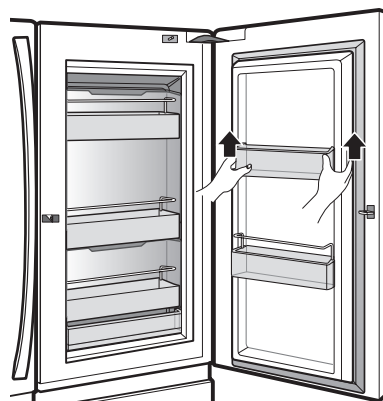

### GRAB-N-GO LOWER SHELF

The Grab-N-Go lower shelf is removable for easy cleaning.

1. To remove the lower shelf, lift the shelf retainer up and out.
2. Remove the two screws from the shelf and pull it straight out.
3. Reverse the procedure to replace the shelf.

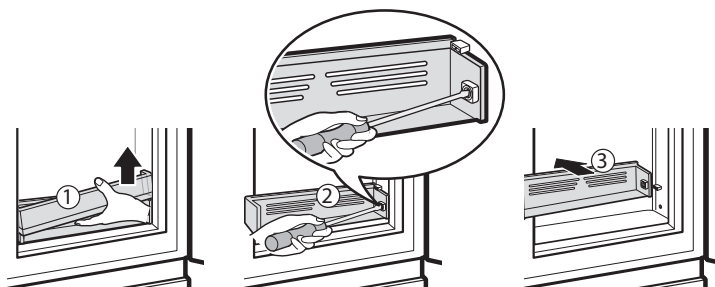

## REPLACING THE AIR FILTER

It is recommended that you replace the air filter:

- Approximately every six months.
- When the **CHANGE AIR FILTER** light turns on.

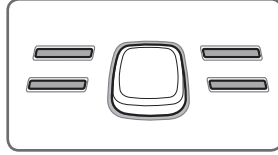

### 1. Remove the Old Filter

Turn the filter cover to the left to detach it from the refrigerator wall. The filter is located on the inside of the filter cover. Remove the filter from the cover and replace it with a new filter.

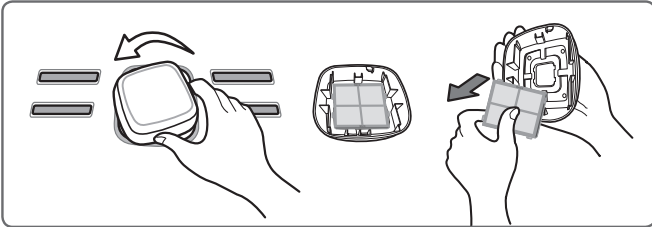

### 2. Install a New Air Filter.

Place the new filter inside of the cover with the side that says "Front" facing outward. Turn the filter cover to the right to attach it to the refrigerator wall.

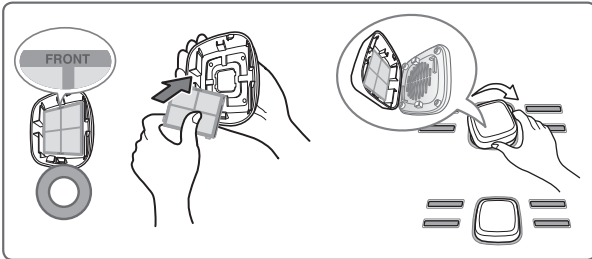

After changing the filter, push and hold the **Air Filter** button for three seconds to reset the filter sensor.

**NOTE:** To purchase a replacement water filter, visit a Sears store or call 1-800-4-MY-HOME®. Also, you may order on-line at [www.sears.com/partsdirect](http://www.sears.com/partsdirect)

## FREEZER SECTION

### EXTRA ICE BIN

1. Pull the Freezer Drawer and the top Pullout Drawer out as far as possible to remove the Extra Ice Bin.
2. Gently lift and pull out the ice bin.
3. To replace, pull both drawers out as far as possible, and set the bin in its correct position in the Pullout Drawer. Close the Pullout Drawer and then the Freezer Drawer.

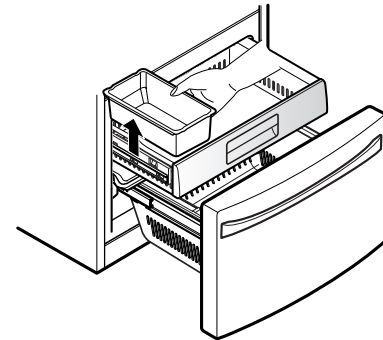
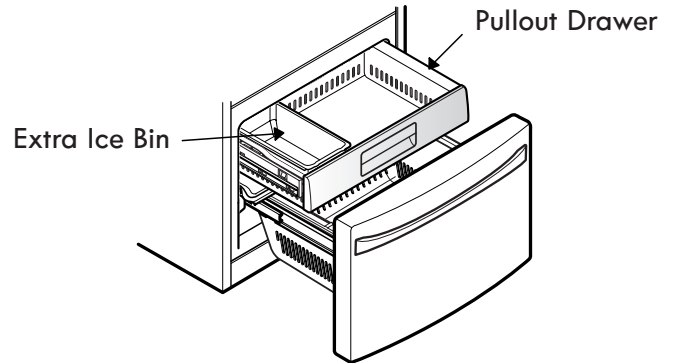

**⚠ CAUTION:** Pinch hazard! Keep hands and feet clear of the bottom of the freezer drawer when opening and closing.

## PULLOUT DRAWERS

### Top Drawer

1. To remove, pull the drawer out to full extension. On the left rail, use a flat blade screwdriver to push in on the tab to release the drawer from the rail, as shown below. Once the left side is loose, push the tab on the right side with your finger to release the drawer. Lift the front of the drawer up, then pull it straight out.

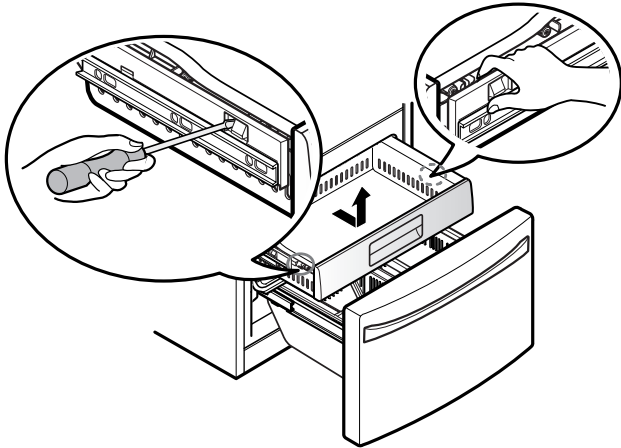

2. To replace, slightly tilt up the front of the drawer, insert the drawer into the frame, and push the drawer back into place until you hear a click.

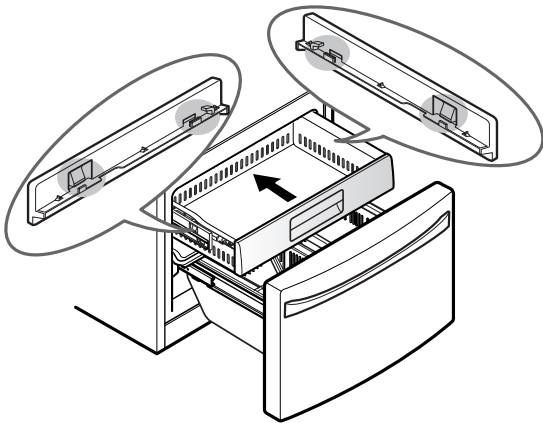

### Middle Drawer

1. To remove, pull the drawer out to full extension. Lift the front of the drawer up, then pull it straight out.

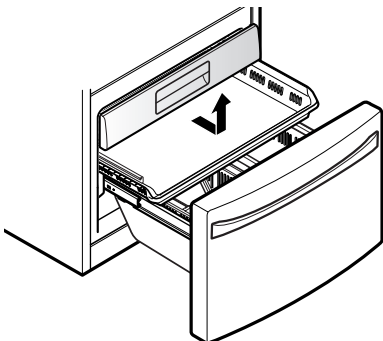

2. To replace, slightly tilt up the front of the drawer, insert the drawer into the frame, and push it back into place.

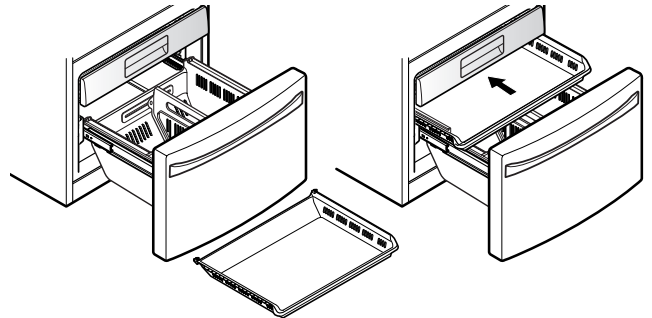

## DURABASE

1. To remove the Durabase, push it to the back as much as possible. Tilt up the front of the Durabase and pull straight out.
2. To replace, insert the Durabase in the rail assembly.

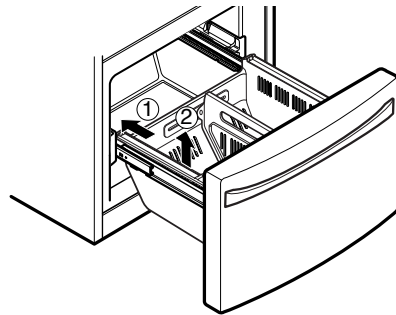

## DURABASE DIVIDER

The Durabase divider allows you to organize the Durabase area into sections. It can be adjusted from side to side to accommodate items of different sizes.

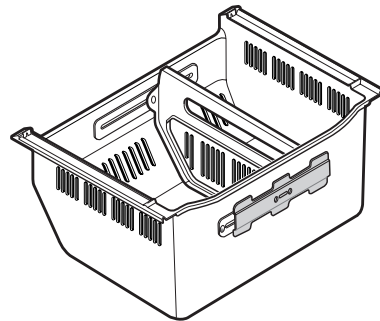

- ⚠ WARNING:** If the Durabase divider is removed, there is enough open space for children or pets to crawl inside. To prevent accidental child and pet entrapment or suffocation risk, DO NOT allow children or pets to touch or go near the drawer.

# WATER FILTER

## WATER FILTER CHANGE FILTER

It is recommended that you replace the water filter:

- Approximately every six months.
- When the water filter indicator turns on.
- When the water dispenser output decreases.
- When the ice cubes are smaller than normal.

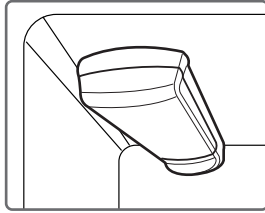

### Before Replacing the Water Filter:

If the top shelf, located below the water filter, is in the highest position, it will need to be removed prior to replacing the water filter.

To remove any shelf—Tilt up the front of the shelf in the direction of ① and lift it in the direction of ②. Pull the shelf out.

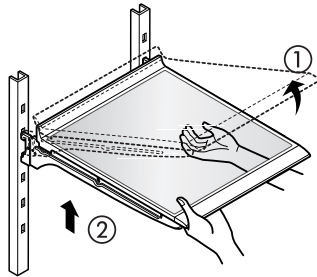

### 1. Remove the old water filter.

- Lower or remove the top left shelf to allow the water filter to rotate all the way down.
- Pinch the sides to open the water filter cover.

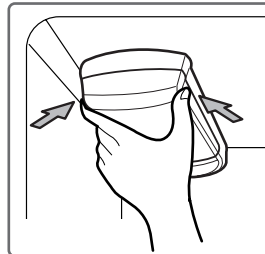

**NOTE:** Replacing the water filter causes a small amount of water (around 1 oz. or 25 cc) to drain. Place a cup under the front end of the water filter cover to collect any leaking water. Hold the water filter upright, once it is removed, to prevent any remaining water from spilling out of the water filter.

- Pull the water filter downward and pull out. Make sure to rotate the filter down completely before pulling it out of the manifold hole.

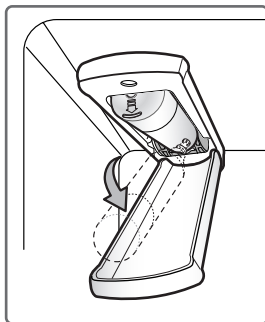

### 2. Replace with a new water filter.

- Take the new water filter out of its packing and remove the protective cover from the o-rings. With water filter tabs in the horizontal position, push the new water filter into the manifold hole until it stops.

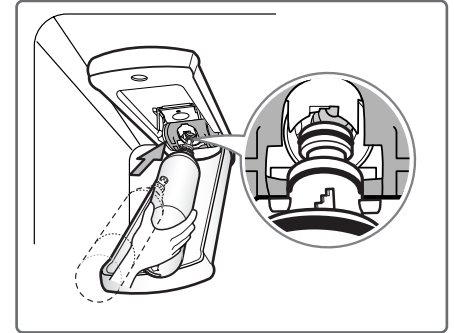

- Rotate the water filter up into position and close the cover. The cover will click when closed correctly.

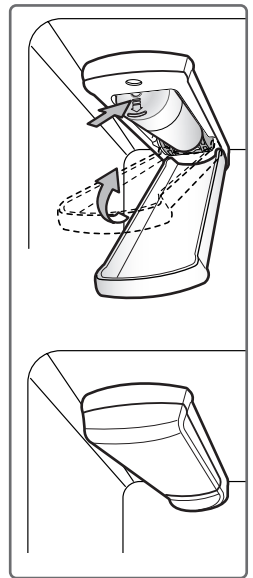

- After the water filter is replaced, dispense 2.5 gallons of water (flush for approximately 5 minutes) to remove trapped air and contaminants from the system. Do not dispense the entire 2.5 gallon amount continuously. Depress and release the dispenser pad for cycles of 30 seconds ON and 60 seconds OFF.

### 4. Water Filter Bypass Plug

Keep the water filter bypass plug. You **MUST** use the water filter bypass plug when a replacement water filter cartridge is not available.

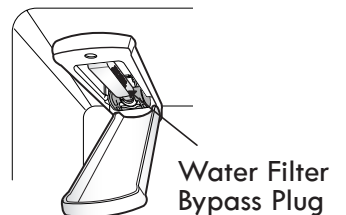

**CAUTION:** DO NOT operate the refrigerator without the water filter or the water filter plug installed.

**NOTE:** To purchase a replacement water filter, visit a Sears store or call 1-800-4-MY-HOME®. Also, you may order on-line at [www.sears.com/partsdirect](http://www.sears.com/partsdirect)

Performance Data Sheet

The concentration of the indicated substances in water entering the system was reduced to a concentration less than or equal to the permissible limit for water leaving the system as specified in NSF/ANSI Standard 42 and Standard 53.



System tested and certified by NSF International against NSF/ANSI Standard 42 and Standard 53 for the reduction of substances listed below.

| Contaminant Reduction                           | Average Influent | NSF specified Challenge Concentration               | Avg % Reduction | Average Product Water Concentration | Max Permissible Product Water Concentration | NSF Reduction Requirements | NSF Test Report |
|---|------------------|---|-----------------|-------------------------------------|---|----------------------------|-----------------|
| Chlorine Taste and Odor                         | 2.1 mg/L         | 2.0 mg/L ± 10%                                      | 97.2%           | 0.06 mg/L                           | N/A   | ≥ 50%                      | J-00049247      |
| Nominal Particulate Class I, , ≥0.5 to < 1.0 µm | 5,600,000 pts/mL | At least 10,000 particles/mL                        | 98.7%           | 73,000 pts/ml                       | N/A   | ≥85%                       | J-00049282      |
| Asbestos  | 190 MFL          | 107 to 108 MFL; fibers greater than 10 µm in length | >99%            | < 1 MFL                             | N/A   | ≥99%                       | J-0004928       |
| Atrazine  | 0.0094 mg/L      | 0.009 mg/L ± 10%                                    | 94.7%           | 0.00005 mg/L                        | 0.003 mg/L                                  | N/A                        | J-00049293      |
| Benzene   | 0.016 mg/L       | 0.015 mg/L ± 10%                                    | 96.7%           | 0.005 mg/L                          | 0.005 mg/L                                  | N/A                        | J-00049300      |
| Carbofuran                                      | 0.08 mg/L        | 0.08 mg/L ± 10%                                     | 98.1%           | 0.002 mg/L                          | 0.04 mg/L                                   | N/A                        | J-00049294      |
| Lindane   | 0.002 mg/L       | 0.002 mg/L ± 10%                                    | 98.2%           | 0.00004 mg/L                        | 0.0002 mg/L                                 | N/A                        | J-00051975      |
| P-Dichlorobenzene                               | 0.22 mg/L        | 0.225 mg/L ± 10%                                    | 99.8%           | 0.0005 mg/L                         | 0.075 mg/L                                  | N/A                        | J-00049298      |
| Toxaphene                                       | 0.014 mg/L       | 0.015 mg/L ± 10%                                    | 93%             | 0.001 mg/L                          | 0.003 mg/L                                  | N/A                        | J-00049302      |
| 2,4-D   | 0.213 mg/L       | 0.210 mg/L ± 10%                                    | 95.2%           | 0.009 mg/L                          | 0.07 mg/L                                   | N/A                        | J-00049284      |
| Lead pH @6.5                                    | 0.150 mg/L       | 0.15 mg/L ± 10%                                     | >99.3%          | 0.001 mg/L                          | 0.010 mg/L                                  | N/A                        | J-00051974      |
| Lead pH @8.5                                    | 0.150 mg/L       | 0.15 mg/L ± 10%                                     | >99.3%          | 0.001 mg/L                          | 0.010 mg/L                                  | N/A                        | J-00049277      |
| Mercury @ pH 6.5                                | 0.0059 mg/L      | 0.006 mg/L ± 10%                                    | 96.1            | 0.0002 mg/L                         | 0.002 mg/L                                  | N/A                        | J-00053886      |
| Mercury @ pH 8.5                                | 0.0058 mg/L      | 0.006 mg/L ± 10%                                    | 90.1            | 0.0006 mg/L                         | 0.002 mg/L                                  | N/A                        | J-00051972      |
| Cyst*   | 120,000 cysts/L  | Minimum 50,000 cysts/L                              | 99.99%          | <1 cyst/L                           | N/A   | ≥99.95%                    | J-00049281      |

\* Based on the use of Cryptosporidium parvum oocysts

## WATER FILTER

| Application Guidelines/Water Supply Parameters |                             |
|--|-----------------------------|
| Service Flow                                   | 0.5 gpm (1.9 lpm)           |
| Water Supply                                   | Potable Water               |
| Water Pressure                                 | 40-120 psi (138 - 827 kPa)  |
| Water Temperature                              | 33°F - 100°F (0.6°C - 38°C) |

It is essential that the manufacturer's recommended installation, maintenance and water filter replacement requirements be carried out for the product to perform as advertised.

**NOTE:** While the testing was performed under standard laboratory conditions, actual performance may vary.

For estimated costs of replacement elements, please call 1-800-469-4663 or visit our website at [www.sears.com/partsdirect](http://www.sears.com/partsdirect)

3M is a trademark of 3M Company.

NSF is a trademark of NSF International.

© 2009 3M Company. All rights reserved.

## WARNING

**To reduce the risk associated with ingestion of contaminants: Do not use with water that is microbiologically unsafe or of unknown quality without adequate disinfection before and after of the system.** Systems certified for cyst reduction may be used on disinfected water that may contain filterable cysts. EPA Establishment Number 10350-MN-005

## CAUTION

**To reduce the risk associated with property damage due to water leakage:**

- **Read and follow** the Water Filter instructions before installation and use of this system.
- Installation and use **MUST** comply with all state and local plumbing codes.
- **Do not** install if water pressure exceeds 120 psi (827 kPa). Contact a plumbing professional if you are uncertain of how to check your water pressure.
- **Do not** install where water hammer conditions may occur. If water hammer conditions exist, you must install a water hammer arrester. Contact a plumbing professional if you are uncertain of how to check for this condition.
- **Do not** install on hot water supply lines. The maximum operating water temperature of this water filter system is 100°F (38°C).
- **Protect water filter from freezing.** Do not operate refrigerator in ambient conditions below 55°F (12.7°C). Drain water filter when storing unit in temperatures below 40°F (4.4°C).
- The disposable water filter must be replaced every six months, at the rated capacity, or if a noticeable reduction in flow rate occurs.



State of California  
Department of Public Health  
Water Treatment Device  
Certificate Number  
09 - 2019

Date Issued: December 15, 2009

---

---

**Manufacturer:** Sears Roebuck and Co.

---

---

The water treatment device(s) listed on this certificate have met the testing requirements pursuant to Section 116830 of the Health and Safety Code for the following health related contaminants:

**Microbiological Contaminants and Turbidity**

Cysts

**Organic Contaminants**

2,4-D Reduction  
Atrazine  
Benzene  
Carbofuran  
Lindane  
p-Dichlorobenzene  
Toxaphene

**Inorganic/Radiological Contaminants**

Asbestos  
Lead  
Mercury

---

**Rated Service Capacity:** 200 gal

**Rated Service Flow:** 0.5 gpm

---

**Conditions of Certification:**

## CARE AND CLEANING

### **! WARNING**



#### **Explosion Hazard**

Use non-flammable cleaner. Failure to do so can result in fire, explosion, or death.

Both the refrigerator and freezer sections defrost automatically; however, clean both sections about once a month to prevent odors. Wipe up spills immediately.

#### **GENERAL CLEANING TIPS**

- Unplug the refrigerator or disconnect power.
- Remove all removable parts, such as shelves, crispers, etc. Refer to sections in *Using Your Refrigerator* for removal instructions.
- Use a clean sponge or soft cloth and a mild detergent in warm water. Do not use abrasive or harsh cleaners.
- Hand wash, rinse and dry all surfaces thoroughly.
- Plug in the refrigerator or reconnect power.

#### **EXTERIOR**

Waxing external painted metal surfaces helps provide rust protection. Do not wax plastic parts. Wax painted metal surfaces at least twice a year using appliance wax (or auto paste wax). Apply wax with a clean, soft cloth.

For products with a stainless steel exterior, use a clean sponge or soft cloth and a mild detergent in warm water. Do not use abrasive or harsh cleaners. Dry thoroughly with a soft cloth.

#### **INSIDE WALLS (allow the freezer to warm up so the cloth will not stick)**

To help remove odors, you can wash the inside of the refrigerator with a mixture of baking soda and warm water. Mix 2 tablespoons of baking soda to 1 quart of water (26 g soda to 1 liter water.) Be sure the baking soda is completely dissolved so it does not scratch the surfaces of the refrigerator.

**! CAUTION:** While cleaning the inside of the refrigerator, do not spray water.

#### **DOOR LINERS AND GASKETS**

Use a clean sponge or soft cloth and a mild detergent in warm water. Do not use cleaning waxes, concentrated detergents, bleaches, or cleaners containing petroleum on plastic refrigerator parts.

#### **PLASTIC PARTS (Covers and Panels)**

Use a clean sponge or soft cloth and a mild detergent in warm water. Do not use window sprays, abrasive cleansers, or flammable fluids. These can scratch or damage the material.

#### **CONDENSER COILS**

Use a vacuum cleaner with an attachment to clean the condenser cover and vents. Do not remove the panel covering the condenser coil area.

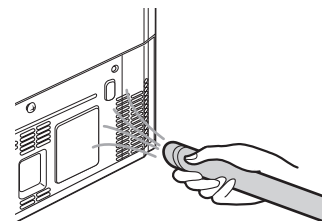

**LIGHT BULB REPLACEMENT****! WARNING****Electrical Shock Hazard**

Before replacing a Compartment Lamp, either unplug the refrigerator or turn off power at the circuit breaker or fuse box.

**NOTE:** The refrigerator and freezer compartment lights have LED interior lighting, and service should be performed by a qualified technician.

**POWER INTERRUPTIONS**

1. If the power will be out for 24 hours or less, keep all refrigerator doors closed to help foods stay cold and frozen.
2. If the power will be out for more than 24 hours, remove all frozen food and store it in a frozen food locker.

**WHEN YOU GO ON VACATION**

**If you choose to leave the refrigerator on while you are away,** follow these steps to prepare your refrigerator before you leave.

1. Use up any perishables and freeze other items.
2. Turn off the icemaker and empty the ice bin.

**If you choose to turn the refrigerator off before you leave,** follow these steps.

1. Remove all food from the refrigerator.
2. Depending on your model, set the thermostat control (refrigerator control) to OFF. See the **Setting the Controls** section.
3. Clean the refrigerator, wipe it and dry well.
4. Tape rubber or wood blocks to the tops of both doors to prop them open far enough for air to get in. This stops odor and mold from building up.

**WHEN YOU MOVE**

When you are moving your refrigerator to a new home, follow these steps to prepare it for the move.

1. Remove all food from the refrigerator and pack all frozen food in dry ice.
2. Unplug the refrigerator.
3. Clean, wipe and dry thoroughly.
4. Take out all removable parts, wrap them well and tape them together so they do not shift and rattle during the move. Refer to the **Using your Refrigerator** section for removal instructions.
5. Depending on the model, raise the front of the refrigerator so it rolls easier OR screw in the leveling legs all the way so they do not scrape the floor. See the **Door Closing** section.
6. Tape the doors shut and tape the power cord to the refrigerator cabinet.

When you get to your new home, put everything back and refer to the **Refrigerator Installation** section for preparation instructions.

# CONNECTING THE WATER LINE

## BEFORE YOU BEGIN

This water line installation is not covered by the refrigerator warranty. Follow these instructions carefully to minimize the risk of expensive water damage.

Water hammer (water banging in the pipes) in house plumbing can cause damage to refrigerator parts and can lead to water leakage or flooding. Call a qualified plumber to correct water hammer before installing the water supply line to the refrigerator.

**⚠ CAUTION:** To prevent burns and product damage, only connect the refrigerator water line to a cold water supply.

If you use your refrigerator before connecting the water line, make sure the icemaker power switch is in the **OFF (O)** position.

**⚠ CAUTION:** Do not install the icemaker tubing in areas where temperatures fall below freezing.

## WATER PRESSURE

**A cold water supply.** The water pressure must be between 20 and 120 psi on models without a water filter and between 40 and 120 psi on models with a water filter.

If a **reverse osmosis water filtration system** is connected to your cold water supply, this water line installation is not covered by the refrigerator warranty. Follow the following instructions carefully to minimize the risk of expensive water damage.

If a **reverse osmosis water filtration system** is connected to your cold water supply, the water pressure to the reverse osmosis system needs to be a minimum of 40 to 60 psi (2.8 kgf/cm<sup>2</sup> ~ 4.2 kgf/cm<sup>2</sup>, less than 2.0~3.0 sec. to fill a cup of 7 oz capacity).

If the water pressure from the reverse osmosis system is less than 21 psi or 1.5 kgf/cm<sup>2</sup> (takes more than 4.0 sec to fill a cup of 7 oz capacity):

- Check to see if the sediment filter in the reverse osmosis system is blocked. Replace the filter if necessary.
- Allow the storage tank on the reverse osmosis system to refill after heavy usage.
- If the issue concerning water pressure from reverse osmosis remains, call a licensed, qualified plumber.
- All installations must be in accordance with local plumbing code requirements.

**⚠ CAUTION:** Wear eye protection during installation to prevent injury.

## WHAT YOU WILL NEED

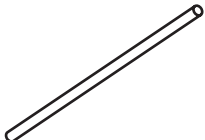
- **Copper Tubing**, 1/4 in. outer diameter, to connect the refrigerator to the water supply. Be sure both ends of the tubing are cut square. 
- To determine how much tubing you need: measure the distance from the water valve on the back of the refrigerator to the water supply pipe. Then, add 8 feet (2.4 m). Be sure there is sufficient extra tubing (about 8 feet [2.4 m] coiled into 3 turns of about 10 in. [25 cm] diameter) to allow the refrigerator to move out from the wall after installation.

- **Power drill.**
- **1/2 in. or adjustable wrench.**
- **Flat blade and Phillips head screwdrivers.**

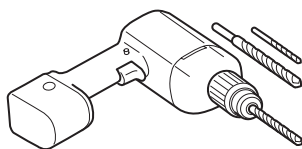
- **Two 1/4 in. outer diameter compression nuts and 2 ferrules (sleeves)** to connect the copper tubing to the shutoff valve and the refrigerator water valve. 

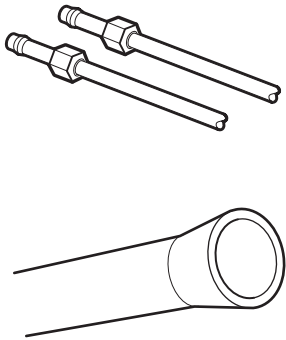
- If your existing copper water line has a flared fitting at the end, you will need an **adapter** (available at plumbing supply stores) to connect the water line to the refrigerator OR you can cut off the flared fitting with a tube cutter and then use a compression fitting. 

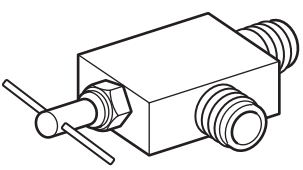
- **Shutoff valve to connect to the cold water line.** The shutoff valve should have a water inlet with a minimum inside diameter of 5/32 in. at the point of connection to the COLD WATER LINE. Saddle-type shutoff valves are included in many water supply kits. Before purchasing, make sure a saddle-type valve complies with your local plumbing codes. 

**NOTE:** A Self Piercing Saddle Type Water Valve should not be used.

## **⚠ WARNING**

### **Electrical Shock Hazard**

When using any electrical device (such as a power drill) during installation, be sure the device is battery powered, double insulated or grounded in a manner that will prevent the hazard of electric shock.

## INSTALLATION INSTRUCTIONS

Install the shutoff valve on the nearest frequently used drinking water line.

### 1. SHUT OFF THE MAIN WATER SUPPLY

Turn on the nearest faucet to relieve the pressure on the line.

### 2. CHOOSE THE VALVE LOCATION

Choose a location for the valve that is easily accessible. It is best to connect into the side of a vertical water pipe. When it is necessary to connect into a horizontal water pipe, make the connection to the top or side, rather than at the bottom, to avoid drawing off any sediment from the water pipe.

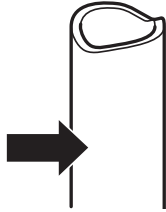

### 3. DRILL THE HOLE FOR THE VALVE

Drill a 1/4 in. hole in the water pipe using a sharp bit. Remove any burrs resulting from drilling the hole in the pipe. Be careful not to allow water to drain into the drill. Failure to drill a 1/4 in. hole may result in reduced ice production or smaller cubes.

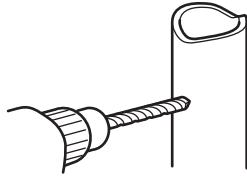

**NOTE:** The hookup line cannot be white, plastic tubing. Licensed plumbers must use only copper tubing (NDA tubing #49595 or #49599) or Cross Link Polyethylene (PEX) tubing.

### 4. FASTEN THE SHUTOFF VALVE

Fasten the shutoff valve to the cold water pipe with the pipe clamp.

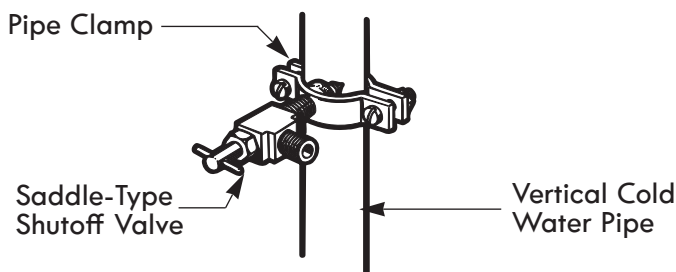

**NOTE:** Commonwealth of Massachusetts Plumbing Codes 248CMR shall be adhered to. Saddle valves are illegal and their use is not permitted in Massachusetts. Consult with your licensed plumber.

### 5. TIGHTEN THE PIPE CLAMP

Tighten the clamp screws until the sealing washer begins to swell.

**NOTE:** Do not overtighten the clamp or you may crush the tubing.

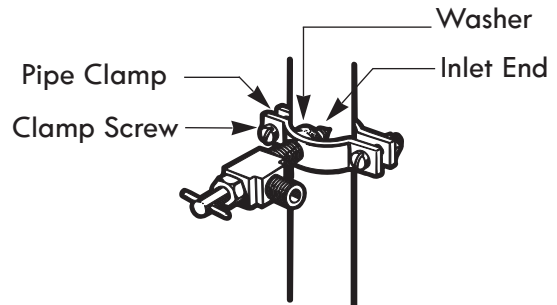

### 6. ROUTE THE TUBING

Route the tubing between the cold water line and the refrigerator.

Route the tubing through a hole drilled in the wall or floor (behind the refrigerator or adjacent base cabinet) as close to the wall as possible.

**NOTE:** Be sure there is sufficient extra tubing (about 8 feet coiled into 3 turns of about 10 in. diameter) to allow the refrigerator to move out from the wall after installation.

### 7. CONNECT THE TUBING TO THE VALVE

Place the compression nut and ferrule (sleeve) for the copper tubing onto the end of the tubing and connect it to the shutoff valve. Make sure the tubing is fully inserted into the valve. Tighten the compression nut securely.

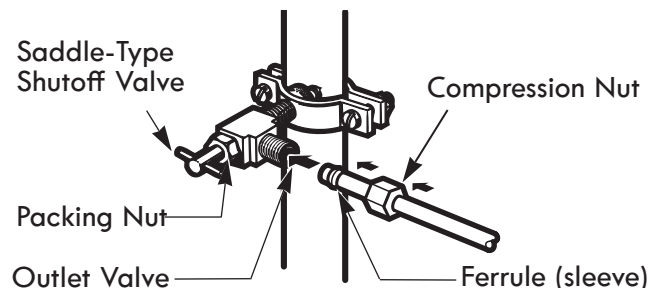

**NOTE:** Commonwealth of Massachusetts Plumbing Codes 248CMR shall be adhered to. Saddle valves are illegal and their use is not permitted in Massachusetts. Consult with your licensed plumber.

## CONNECTING THE WATER LINE

### 8. FLUSH OUT THE TUBING

Turn the main water supply on and flush out the tubing until the water is clear.

Shut the water off at the water valve after about one quart of water has been flushed through the tubing.

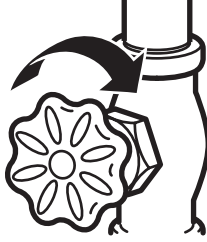

### 9. CONNECT THE TUBING TO THE REFRIGERATOR

**NOTE:** Before making the connection to the refrigerator, be sure that the refrigerator power cord is not plugged into the wall outlet.

1. Remove the plastic flexible cap from the water valve.
2. Place the compression nut and ferrule (sleeve) onto the end of the tubing as shown.
3. Insert the end of the copper tubing into the connection as far as possible. While holding the tubing, tighten the fitting.

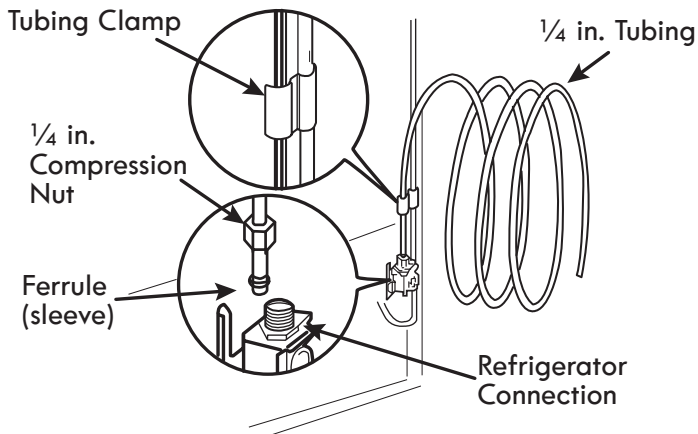

### 10. TURN THE WATER ON AT THE SHUTOFF VALVE

Tighten any connections that leak.

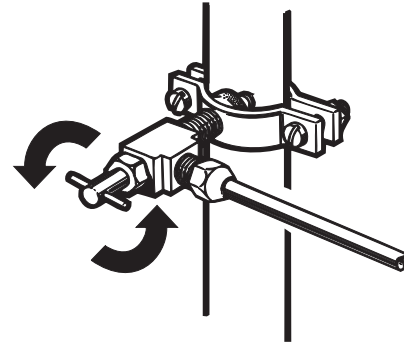

**CAUTION:** Check to see if leaks occur at the water line connections.

### 11. PLUG IN THE REFRIGERATOR

Arrange the coil of tubing so that it does not vibrate against the back of the refrigerator or against the wall. Push the refrigerator back to the wall.

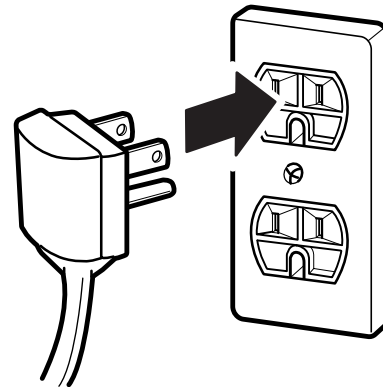

### 12. START THE ICEMAKER

Set the icemaker power switch to the **ON** position.

The icemaker will not begin to operate until it reaches its operating temperature of 15°F (-9°C) or below. It will then begin operation automatically if the icemaker power switch is in the **ON (I)** position.

# TROUBLESHOOTING GUIDE

Before conducting troubleshooting, make sure that the following basic requirements are met:

|                                      |   |
|--------------------------------------|---|
| Service Flow                         | 0.5 gpm (1.9 lpm)   |
| Water Supply                         | Potable Water   |
| Water Pressure                       | 40-120 psi (138 - 827 kPa)                                |
| Operating Ambient Temperature Limits | 55°F - 110°F  |
| Electrical Ratings                   | 115 Volts, 60 Hz, AC only, and fused at 15 or 20 amperes. |

## COOLING

| Problem   | Possible Causes   | Solutions  |
|---|---|--|
| Refrigerator and Freezer section are not cooling. | The refrigerator control is set to OFF (some models).             | Turn the control ON. Refer to the <b>Setting the Controls</b> section for proper temperature settings.   |
|   | Refrigerator is set to demo mode.                                 | Demo Mode allows the lights and control display to work normally while disabling cooling to save energy while on the showroom floor. Refer to the <b>Setting the Controls</b> section for instructions on how to disable Demo Mode.  |
|   | Refrigerator is in the defrost cycle.                             | During the defrost cycle, the temperature of each compartment may rise slightly. Wait 30 minutes and confirm the proper temperature has been restored once the defrost cycle has completed.  |
|   | Refrigerator was recently installed.                              | It may take up to 24 hours for each compartment to reach the desired temperature.  |
|   | Refrigerator was recently relocated.                              | If the refrigerator was stored for a long period of time or moved on its side, it is necessary for the refrigerator to stand upright for 24 hours before connecting it to power.   |
| Cooling System runs too much.                     | Refrigerator is replacing an older model.                         | Modern refrigerators require more operating time but use less energy due to more efficient technology.   |
|   | Refrigerator was recently plugged in or power restored.           | The refrigerator will take up to 24 hours to cool completely.  |
|   | Door opened often or a large amount of food / hot food was added. | Adding food and opening the door warms the refrigerator, requiring the compressor to run longer in order to cool the refrigerator back down. In order to conserve energy, try to get everything you need out of the refrigerator at once, keep food organized so it is easy to find, and close the door as soon as the food is removed. (Refer to the <b>Food Storage Guide</b> .) |
|   | Doors are not closed completely.                                  | Firmly push the doors shut. If they will not shut all the way, see the <b>Doors will not close completely or pop open</b> section in <b>Parts &amp; Features Troubleshooting</b> .   |
|   | Refrigerator is installed in a hot location.                      | The compressor will run longer under warm conditions. At normal room temperatures (70°F) expect your compressor to run about 40% to 80% of the time. Under warmer conditions, expect it to run even more often. The refrigerator should not be operated above 110°F.   |
|   | Condenser / back cover is clogged.                                | Use a vacuum cleaner with an attachment to clean the condenser cover and vents. Do not remove the panel covering the condenser coil area.  |

**COOLING**

| Problem                                      | Possible Causes   | Solutions  |
|--|---|--|
| Refrigerator or Freezer section is too warm. | Refrigerator was recently installed.                                | It may take up to 24 hours for each compartment to reach the desired temperature.  |
|  | Air vents are blocked.  | Rearrange items to allow air to flow throughout the compartment. Refer to the Airflow diagram in the <b>Using Your Refrigerator</b> section.   |
|  | Doors are opened often or for long periods of time.                 | When the doors are opened often or for long periods of time, warm, humid air enters the compartment. This raises the temperature and moisture level within the compartment. To lessen the effect, reduce the frequency and duration of door openings.              |
|  | Unit is installed in a hot location.                                | The refrigerator should not be operated in temperatures above 110F.  |
|  | A large amount of food or hot food was added to either compartment. | Adding food warms the compartment requiring the cooling system to run. Allowing hot food to cool to room temperature before putting it in the refrigerator will reduce this effect.  |
|  | Doors not closed correctly.   | See the <b>Doors will not close correctly or pop open</b> section in <b>Parts &amp; Features Troubleshooting</b> .   |
|  | Temperature control is not set correctly.                           | If the temperature is too warm, adjust the control one increment at a time and wait for the temperature to stabilize. Refer to the <b>Setting the Controls</b> section for more information.   |
|  | Defrost cycle has recently completed.                               | During the defrost cycle, the temperature of each compartment may rise slightly and condensation may form on the back wall. Wait 30 minutes and confirm the proper temperature has been restored once the defrost cycle has completed.                             |
| Interior moisture buildup.                   | Doors are opened often or for long periods of time.                 | When the doors are opened often or for long periods of time, warm, humid air enters the compartment. This raises the temperature and moisture level within the compartment. To lessen the effect, reduce the frequency and duration of door openings.              |
|  | Doors not closed correctly.   | See the <b>Doors will not close correctly</b> section in the <b>Troubleshooting</b> section.   |
|  | Weather is humid.   | Humid weather allows additional moisture to enter the compartments when the doors are opened leading to condensation or frost. Maintaining a reasonable level of humidity in the home will help to control the amount of moisture that can enter the compartments. |
|  | Defrost cycle recently completed.                                   | During the defrost cycle, the temperature of each compartment may rise slightly and condensation may form on the back wall. Wait 30 minutes and confirm that the proper temperature has been restored once the defrost cycle has completed.                        |
|  | Food is not packaged correctly.                                     | Food stored uncovered or unwrapped, and damp containers can lead to moisture accumulation within each compartment. Wipe all containers dry and store food in sealed packaging to prevent condensation and frost.   |



## COOLING/ICE &amp; WATER

| Problem   | Possible Causes   | Solutions   |
|---|---|---|
| Food is freezing in the refrigerator compartment.   | Food with high water content was placed near an air vent.   | Rearrange items with high water content away from air vents.  |
|   | Refrigerator temperature control is set incorrectly.  | If the temperature is too cold, adjust the control one increment at a time and wait for the temperature to stabilize.   |
|   | Refrigerator is installed in a cold location.   | When the refrigerator is operated in temperatures below 41°F (5°C), food can freeze in the refrigerator compartment. The refrigerator should not be operated in temperatures below 55°F (13°C).   |
| Frost or ice crystals form on frozen food (outside of package).                                     | Door is opened frequently or for long periods of time.  | When the doors are opened often or for long periods of time, warm, humid air enters the compartment. This raises the temperature and moisture level within the compartment. Increased moisture will lead to frost and condensation. To lessen the effect, reduce the frequency and duration of door openings. |
|   | Door is not closing properly.   | Refer to the <b>Doors will not close correctly or pop open</b> section in the Troubleshooting section.  |
| Refrigerator or Freezer section is too cold.  | Incorrect temperature control settings.   | If the temperature is too cold, adjust the control one increment at a time and wait for the temperature to stabilize. Refer to the <b>Setting the Controls</b> section for more information.  |
| Frost or ice crystals on frozen food (inside of sealed package).                                    | Condensation from food with a high water content has frozen inside of the food package.           | This is normal for food items with a high water content.  |
|   | Food has been left in the freezer for a long period of time.                                      | Do not store food items with high water content in the freezer for a long period of time.   |
| Items in the Cheese & Butter and Condiment bins are not as cool as other items in the refrigerator. | The Cheese & Butter and Condiment bins will be slightly warmer than the refrigerator compartment. | This is normal. Items that you would like to keep cooler should be stored in the refrigerator section.  |
| Icemaker is not making enough ice.  | Demand exceeds ice storage capacity.  | The icemaker will produce approximately 70~210 cubes in a 24 hour period.   |
|   | House water supply is not connected, valve is not turned on fully, or valve is clogged.           | Connect the refrigerator to a cold water supply with adequate pressure and turn the water shutoff valve fully open.<br><br>If the problem persists, it may be necessary to contact a plumber.   |
|   | Water filter has been exhausted.  | It is recommended that you replace the water filter: <ul style="list-style-type: none"> <li>• Approximately every six months.</li> <li>• When the water filter indicator turns on.</li> <li>• When the water dispenser output decreases.</li> <li>• When the ice cubes are smaller than normal.</li> </ul>    |
|   | Low house water supply pressure.  | The water pressure must be between 20 and 120 psi on models without a water filter and between 40 and 120 psi on models with a water filter.  |
|   | Reverse Osmosis filtration system is used.  | Reverse osmosis filtration systems can reduce the water pressure below the minimum amount and result in icemaker issues. (Refer to <b>Water Pressure</b> section.)  |
|   | Tubing connecting refrigerator to house supply valve is kinked.                                   | Straighten or repair the water supply line and arrange it to prevent future kinks.  |

## ICE &amp; WATER

| Problem  | Possible Causes  | Solutions  |
|--|--|--|
| Icemaker is not making enough ice (continued). | Doors are opened often or for long periods of time.        | If the doors of the unit are opened often, ambient air will warm the refrigerator which will prevent the unit from maintaining the set temperature. Lowering the refrigerator temperature can help, as well as not opening the doors as frequently.  |
|  | Doors are not closed completely.                           | If the doors are not properly closed, ice production will be affected. See the <b>Doors will not close completely or pop open</b> section in Parts & Features Troubleshooting for more information.  |
|  | The temperature setting for the freezer is too warm.       | The recommended temperature for the freezer compartment for normal ice production is 0°F. If the freezer temperature is warmer, ice production will be affected.   |
| Dispensing water slowly.                       | Water filter has been exhausted.                           | It is recommended that you replace the water filter: <ul style="list-style-type: none"> <li>• Approximately every six months.</li> <li>• When the water filter indicator turns on.</li> <li>• When the water dispenser output decreases.</li> <li>• When the ice cubes are smaller than normal.</li> </ul>   |
|  | Reverse osmosis filtration system is used.                 | Reverse osmosis filtration systems can reduce the water pressure below the minimum amount and result in icemaker issues.<br>If the problem persists, it may be necessary to contact a plumber.   |
|  | Low house water supply pressure.                           | The water pressure must be between 20 and 120 psi on models without a water filter and between 40 and 120 psi on models with a water filter.<br>If the problem persists, it may be necessary to contact a plumber.   |
| Not dispensing ice.                            | Doors are not closed completely.                           | Ice will not dispense if any of the refrigerator doors are left open.  |
|  | Infrequent use of the dispenser.                           | Infrequent use of the ice dispenser will cause the cubes to stick together over time, which will prevent them from properly dispensing. Check the ice bin for ice cubes clumping/sticking together. If they are, break up the ice cubes to allow for proper operation.   |
|  | The delivery chute is clogged with frost or ice fragments. | Eliminate the frost or ice fragments by removing the ice bin and clearing the chute with a plastic utensil. Dispensing cubed ice can also help prevent frost or ice fragment buildup.  |
|  | The dispenser display is locked.                           | Press and hold the <b>Lock</b> button for three seconds to unlock the control panel and dispenser.   |
|  | Ice bin is empty.  | It may take up to 24 hours for each compartment to reach the desired temperature and for the icemaker to begin making ice. Make sure that the shutoff (arm/sensor) is not obstructed.<br><br>Once the ice supply in the bin has been completely exhausted, it may take up to 90 minutes before additional ice is available, and approximately 24 hours to completely refill the bin. |

## ICE &amp; WATER

| Problem                     | Possible Causes   | Solutions  |
|-----------------------------|---|--|
| Icemaker is not making ice. | Refrigerator was recently installed or icemaker recently connected.                                 | It may take up to 24 hours for each compartment to reach the desired temperature and for the icemaker to begin making ice.   |
|                             | Icemaker not turned on.   | Locate the icemaker ON/OFF switch and confirm that it is in the ON (I) position.   |
|                             | The ice detecting sensor is obstructed.   | Foreign substances or frost on the ice-detecting sensor can interrupt ice production. Make sure that the sensor area is clean at all times for proper operation.   |
|                             | The refrigerator is not connected to a water supply or the supply shutoff valve is not turned on.   | Connect the refrigerator to the water supply and turn the water shutoff valve fully open.  |
|                             | Icemaker shutoff (arm or sensor) obstructed.  | If your icemaker is equipped with an ice shutoff arm, make sure that the arm moves freely. If your icemaker is equipped with the electronic ice shutoff sensor, make sure that there is a clear path between the two sensors.  |
|                             | Reverse osmosis water filtration system is connected to your cold water supply.                     | Reverse osmosis filtration systems can reduce the water pressure below the minimum amount and result in icemaker issues. (Refer to the <b>Water Pressure</b> section.)   |
| Not dispensing water.       | New installation or water line recently connected.  | Dispense 2.5 gallons of water (flush for approximately 5 minutes) to remove trapped air and contaminants from the system. Do not dispense the entire 2.5 gallon amount continuously. Depress and release the dispenser pad for cycles of 30 seconds ON and 60 seconds OFF.                                     |
|                             | The dispenser panel is locked.  | Press and hold the <b>Lock</b> button for three seconds to unlock the control panel and dispenser.   |
|                             | The dispenser is not set for water dispensing.  | The dispenser can be set for ice or water. Make certain that the control panel is set for the proper operation. Press the <b>Water</b> button on the control panel to dispense water.  |
|                             | Refrigerator or freezer doors are not closed properly.  | Water will not dispense if any of the refrigerator doors are left open.  |
|                             | Water filter has been recently removed or replaced.   | After the water filter is replaced, dispense 2.5 gallons of water (flush for approximately 5 minutes) to remove trapped air and contaminants from the system. Do not dispense the entire 2.5 gallon amount continuously. Depress and release the dispenser pad for cycles of 30 seconds ON and 60 seconds OFF. |
|                             | Tubing connecting refrigerator to house supply valve is kinked.                                     | The tubing can kink when the refrigerator is moved during installation or cleaning resulting in reduced water flow. Straighten or repair the water supply line and arrange it to prevent future kinks.   |
|                             | The house water supply is not connected, the valve is not turned on fully, or the valve is clogged. | Connect the refrigerator to the water supply and turn the water shutoff valve fully open.<br><br>If the problem persists, it may be necessary to contact a plumber.  |

ICE & WATER

| Problem                          | Possible Causes  | Solutions   |
|----------------------------------|--|---|
| Ice has bad taste or odor.       | Water supply contains minerals such as sulfur.                                 | A water filter may need to be installed to eliminate taste and odor problems.<br><b>NOTE:</b> In some cases, a filter may not help. It may not be possible to remove all minerals / odor / taste in all water supplies.   |
|                                  | Icemaker was recently installed.   | Discard the first few batches of ice to avoid discolored or bad tasting ice.  |
|                                  | Ice has been stored for too long.  | Ice that has been stored for too long will shrink, become cloudy, and may develop a stale taste. Throw away old ice and make a new supply.  |
|                                  | The food has not been stored properly in either compartment.                   | Rewrap the food. Odors may migrate to the ice if food is not wrapped properly.  |
|                                  | The interior of the refrigerator needs to be cleaned.                          | See the <b>Care and Cleaning</b> section for more information.  |
|                                  | The ice storage bin needs to be cleaned.                                       | Empty and wash the bin (discard old cubes). Make sure that the bin is completely dry before reinstalling it.  |
| Dispensing warm water.           | Refrigerator was recently installed.   | Allow 24 hours after installation for the water storage tank to cool completely.  |
|                                  | The water dispenser has been used recently and the storage tank was exhausted. | Depending on your specific model, the water storage capacity will range from approximately 20 to 30 oz.   |
|                                  | Dispenser has not been used for several hours.                                 | If the dispenser has not been used for several hours, the first glass dispensed may be warm. Discard the first 10 oz.   |
|                                  | Refrigerator is connected to the hot water supply.                             | Make sure that the refrigerator is connected to a cold water pipe.<br><b>⚠WARNING:</b> Connecting the refrigerator to a hot water line may damage the icemaker.   |
| Water has bad taste or odor.     | Water supply contains minerals such as sulfur.                                 | A water filter may need to be installed to eliminate taste and odor problems.   |
|                                  | Water filter has been exhausted.   | It is recommended that you replace the water filter: <ul style="list-style-type: none"> <li>• Approximately every 6 months.</li> <li>• When the water filter indicator turns on.</li> <li>• When the water dispenser output decreases.</li> <li>• When the ice cubes are smaller than normal.</li> </ul>              |
|                                  | Refrigerator was recently installed.   | Dispense 2.5 gallons of water (flush for approximately 5 minutes) to remove trapped air and contaminants from the system. Do not dispense the entire 2.5 gallon amount continuously. Depress and release the dispenser pad for cycles of 30 seconds ON and 60 seconds OFF.  |
| Icemaker is making too much ice. | Icemaker shutoff (arm/sensor) is obstructed.                                   | Empty the ice bin. If your icemaker is equipped with an ice shutoff arm, make sure that the arm moves freely. If your icemaker is equipped with the electronic ice shutoff sensor, make sure that there is a clear path between the two sensors. Reinstall the ice bin and wait 24 hours to confirm proper operation. |

## NOISE

| Problem                         | Possible Causes  | Solutions   |
|---------------------------------|--|---|
| Clicking                        | The defrost control will click when the automatic defrost cycle begins and ends. The thermostat control (or refrigerator control on some models) will also click when cycling on and off.  | Normal Operation  |
| Rattling                        | Rattling noises may come from the flow of refrigerant, the water line on the back of the unit, or items stored on top of or around the refrigerator.   | Normal Operation  |
|                                 | Refrigerator is not resting solidly on the floor.  | Floor is weak or uneven or leveling legs need to be adjusted. See the <b>Door Alignment</b> section.  |
|                                 | Refrigerator with linear compressor was jarred while running.  | Normal Operation  |
| Whooshing                       | Evaporator fan motor is circulating air through the refrigerator and freezer compartments.   | Normal Operation  |
|                                 | Air is being forced over the condenser by the condenser fan.   | Normal Operation  |
| Gurgling                        | Refrigerant flowing through the cooling system.  | Normal Operation  |
| Popping                         | Contraction and expansion of the inside walls due to changes in temperature.   | Normal Operation  |
| Sizzling                        | Water dripping on the defrost heater during a defrost cycle.   | Normal Operation  |
| Vibrating                       | If the side or back of the refrigerator is touching a cabinet or wall, some of the normal vibrations may make an audible sound.  | To eliminate the noise, make sure that the sides and back cannot vibrate against any wall or cabinet. |
| Dripping                        | Water running into the drain pan during the defrost cycle.   | Normal Operation  |
| Pulsating or High-Pitched Sound | Your refrigerator is designed to run more efficiently to keep your food items at the desired temperature. The high efficiency compressor may cause your new refrigerator to run longer than your old one, but it is still more energy efficient than previous models. While the refrigerator is running, it is normal to hear a pulsating or high-pitched sound. | Normal Operation  |

## PARTS &amp; FEATURES

| Problem  | Possible Causes   | Solutions  |
|--|---|--|
| Doors will not close correctly or pop open.                    | Food packages are blocking the door open.   | Rearrange food containers to clear the door and door shelves.  |
|  | Ice bin, crisper cover, pans, shelves, door bins, or baskets are out of position.       | Push bins all the way in and put crisper cover, pans, shelves and baskets into their correct positions. See the <b>Using Your Refrigerator</b> section for more information.   |
|  | The doors were removed during product installation and not properly replaced.           | Remove and replace the doors according to the <b>Removing and Replacing Refrigerator Handles and Doors</b> section.  |
|  | Refrigerator is not leveled properly.   | See <b>Door Alignment</b> in the <b>Refrigeration Installation</b> section to level refrigerator.  |
| Doors are difficult to open.                                   | The gaskets are dirty or sticky.  | Clean the gaskets and the surfaces that they touch. Rub a thin coat of appliance polish or kitchen wax on the gaskets after cleaning.  |
|  | Door was recently closed.   | When you open the door, warmer air enters the refrigerator. As the warm air cools, it can create a vacuum. If the door is hard to open, wait one minute to allow the air pressure to equalize, then see if it opens more easily. |
| Refrigerator wobbles or seems unstable.                        | Leveling legs are not adjusted properly.  | Refer to the <b>Leveling and Door Alignment</b> section.   |
|  | Floor is not level.   | It may be necessary to add shims under the leveling legs or rollers to complete installation.  |
| Lights do not work.  | LED interior lighting failure.  | The refrigerator compartment lamp is LED interior lighting, and service should be performed by a qualified technician. Refer to the <b>Light Bulb Replacement</b> section.   |
| Refrigerator has an unusual odor.                              | The Air Filter may need to be set to the MAX setting or replaced.                       | Set the Air Filter to the MAX setting. If the odor does not go away within 24 hours, the filter may need to be replaced. See the <b>Replacing the Air Filter</b> section for replacement instructions.                           |
| The interior of the refrigerator is covered with dust or soot. | The refrigerator is located near a fire source, such as a fireplace, chimney or candle. | Make sure that the refrigerator is not located near a fire source, such as a fireplace, chimney or candle.   |

Should you experience any problems with your refrigerator, it has the capability of transmitting data via your telephone to the Kenmore Connect Team. This gives you the capability of speaking directly to our trained specialists. The specialist records the data transmitted from your machine and uses it to analyze the issue, providing a fast and effective diagnosis.

If you experience problems with your refrigerator, call 1-800-4-MY-HOME®. Only use the Kenmore Connect System feature when instructed to do so by the Kenmore Connect Team. The transmission sounds that you will hear are normal and sound similar to a fax machine.

Kenmore Connect cannot be activated unless your refrigerator is connected to power. If your refrigerator is unable to turn on, then troubleshooting must be done without using Kenmore Connect.

### Using the Kenmore Connect™ System

The display must be locked in order for you to activate Kenmore Connect. If the display has been locked for over five minutes, you must deactivate the control lock and then reactivate it. To activate the control lock, press and hold the Control Lock button for three seconds. The Control Lock icon will display. Once the controls are locked, follow the specialist's instructions and perform the following steps when requested.

**NOTE:** For best results, use Kenmore Connect with a landline phone.

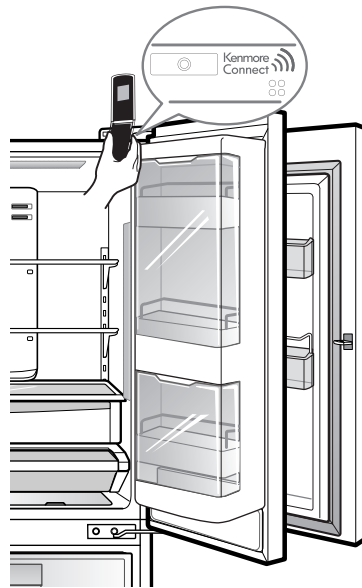

**HOLD** the mouthpiece of your phone in front of the speaker that is located on the right hinge of the refrigerator door, when instructed to do so by the call center. Hold the phone no more than one inch from (but not touching) the speaker.



**PUSH** and hold the Freezer Temp button for three seconds while continuing to hold your phone to the speaker.



**LISTEN** for three beeps. After you hear the three beeps, release the Freezer Temp button. Keep the phone in place until the tone transmission has finished. This takes about 15 seconds, and the display will count down the time. Once the countdown is over and the tones have stopped, resume your conversation with the specialist, who will then be able to assist you in using the information transmitted for analysis.

#### **NOTE:**

- For best results, do not move the phone while the tones are being transmitted.
- If the call center agent is not able to get an accurate recording of the data, you may be asked to try again.

#### **NOTE:**

- Call quality differences by region may affect the function.
- Use the home telephone for better communication performance, resulting in better service.
- Bad call quality may result in poor data transmission from your phone to the machine, which could cause Kenmore Connect to not work properly.

# Get it fixed, at your home or ours!

## Your Home

For troubleshooting, product manuals and expert advice:



[www.managemylife.com](http://www.managemylife.com)

For repair – **in your home** – of **all** major brand appliances, lawn and garden equipment, or heating and cooling systems, **no matter who made it, no matter who sold it!**

For the replacement parts, accessories and owner's manuals that you need to do-it-yourself.

For Sears professional installation of home appliances and items like garage door openers and water heaters.

**1-800-4-MY-HOME<sup>®</sup>** (1-800-469-4663)

Call anytime, day or night (U.S.A. and Canada)

[www.sears.com](http://www.sears.com)    [www.sears.ca](http://www.sears.ca)

## Our Home

For repair of carry-in items like vacuums, lawn equipment, and electronics, call anytime for the location of your nearest

**Sears Parts & Repair Service Center**

**1-800-488-1222** (U.S.A.)

[www.sears.com](http://www.sears.com)

**1-800-469-4663** (Canada)

[www.sears.ca](http://www.sears.ca)

To purchase a protection agreement on a product serviced by Sears:

**1-800-827-6655** (U.S.A.)

**1-800-361-6665** (Canada)

Para pedir servicio de reparación a domicilio, y para ordenar piezas:

**1-888-SU-HOGAR<sup>®</sup>**

(1-888-784-6427)

[www.sears.com](http://www.sears.com)

Au Canada pour service en français:

**1-800-LE-FOYER<sup>MC</sup>**

(1-800-533-6937)

[www.sears.ca](http://www.sears.ca)

The Sears logo, consisting of the word "sears" in a lowercase, sans-serif font.

® Registered Trademark / <sup>TM</sup> Trademark of KCD IP, LLC in the United States, or Sears Brands, LLC in other countries

® Marca Registrada / <sup>TM</sup> Marca de Fábrica de KCD IP, LLC en Estados Unidos, o Sears Brands, LLC in otros países

<sup>MC</sup> Marque de commerce / <sup>MD</sup> Marque déposée de Sears Brands, LLC