

This Owner's Manual is provided and hosted by [Appliance Factory Parts](#).



Haier RBFS21SIAP Owner's Manual

[Shop genuine replacement parts for Haier RBFS21SIAP](#)



[Find Your Haier Refrigerator Parts - Select From 1148 Models](#)

----- Manual continues below -----



CAUTION

READ THIS MANUAL CAREFULLY TO
DIAGNOSE TROUBLE CORRECTLY
BEFORE OFFERING SERVICE .

Refrigerator

SERVICE MANUAL



MODEL: PBFS21EDAW/B/P/S/E
RBFS21TIAW/B/P/S/E
RBFS21SIAW/B/P/S/E
PRFS25EDAP/S/E

Features:

- 1.Chill drawer for delicatessen
- 2.Slide-out shelf for easy food access
- 3.Optimized condensing system
- 4.Pre-cooling for defrosting for freshness storage
- 5.Automatic problem detecting and warning system, door cooling warning system
- 6.Vitamin C technology for fresh food storage
- 7.Ice making
- 8.Intelligent operation for automatic operation
- 9.Dispenser for cold drinks

Haier Group

CONTENTS

CONTENTS	PAGE
1.PARTS IDENTIFICATIONS -----	1
2.DISASSEMBLY of door -----	2
3.CONTROL AND DISPLAY SYSTEM -----	3~8
Control and display panel-----	3~8
4.REFRIGERATION PRINCIPLE -----	9
System flow chart-----	9
4.CIRCUIT DIAGRAM -----	10~11
4.1 Schematic-----	10
4.2 Connect diagram-----	11
5.Sensor and Error code -----	12
6.TROUBLESHOOTING -----	13~30
6.1 Common Troubles in Refrigerators and Remedies-----	13~24
6.2 Instruction of replacing mullion,heater and sensor-----	25~30
7.Other(Icemaker and defrost details) -----	31

PRODUCT CODE and SERIES INTRODUCTION

Model Designations

Bottom Mount

21 - 25 cu ft Refrigerator / Freezer

Details:

P B F S 21 E D A W

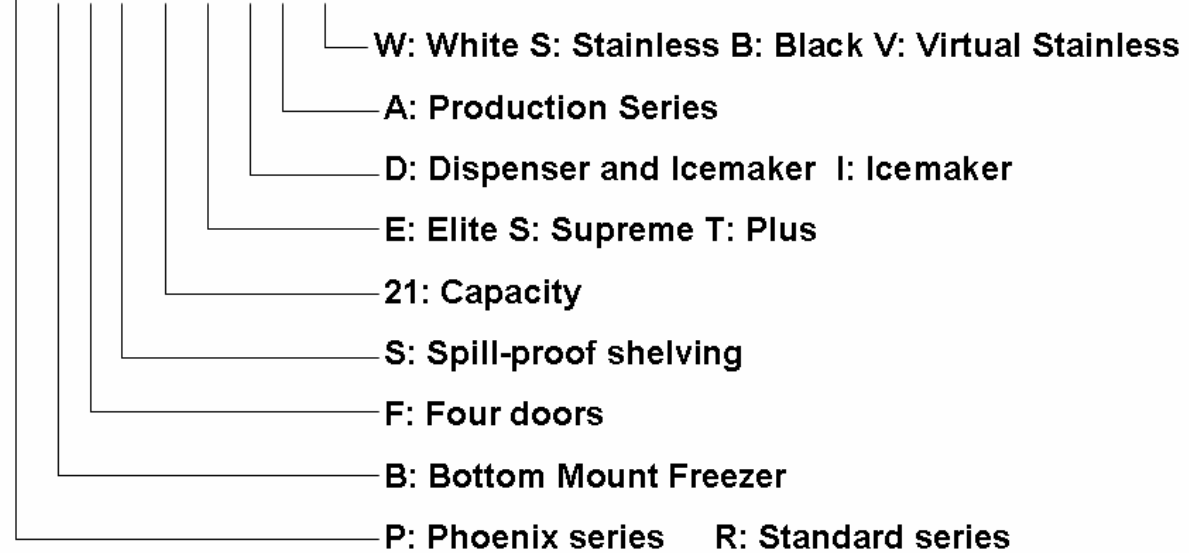

PARTS IDENTIFICATIONS

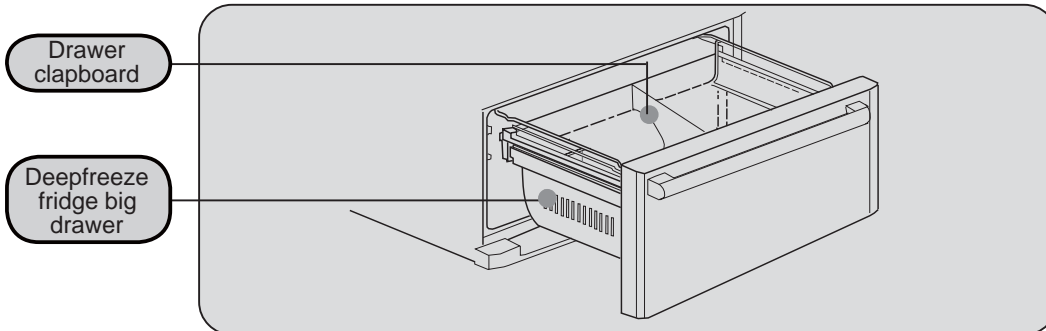
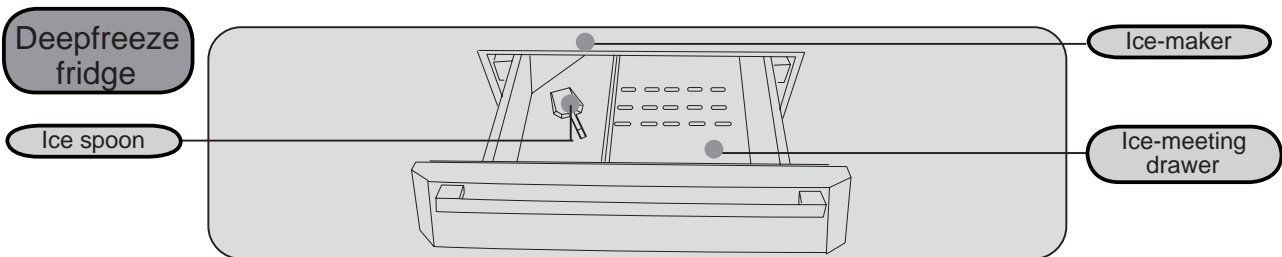
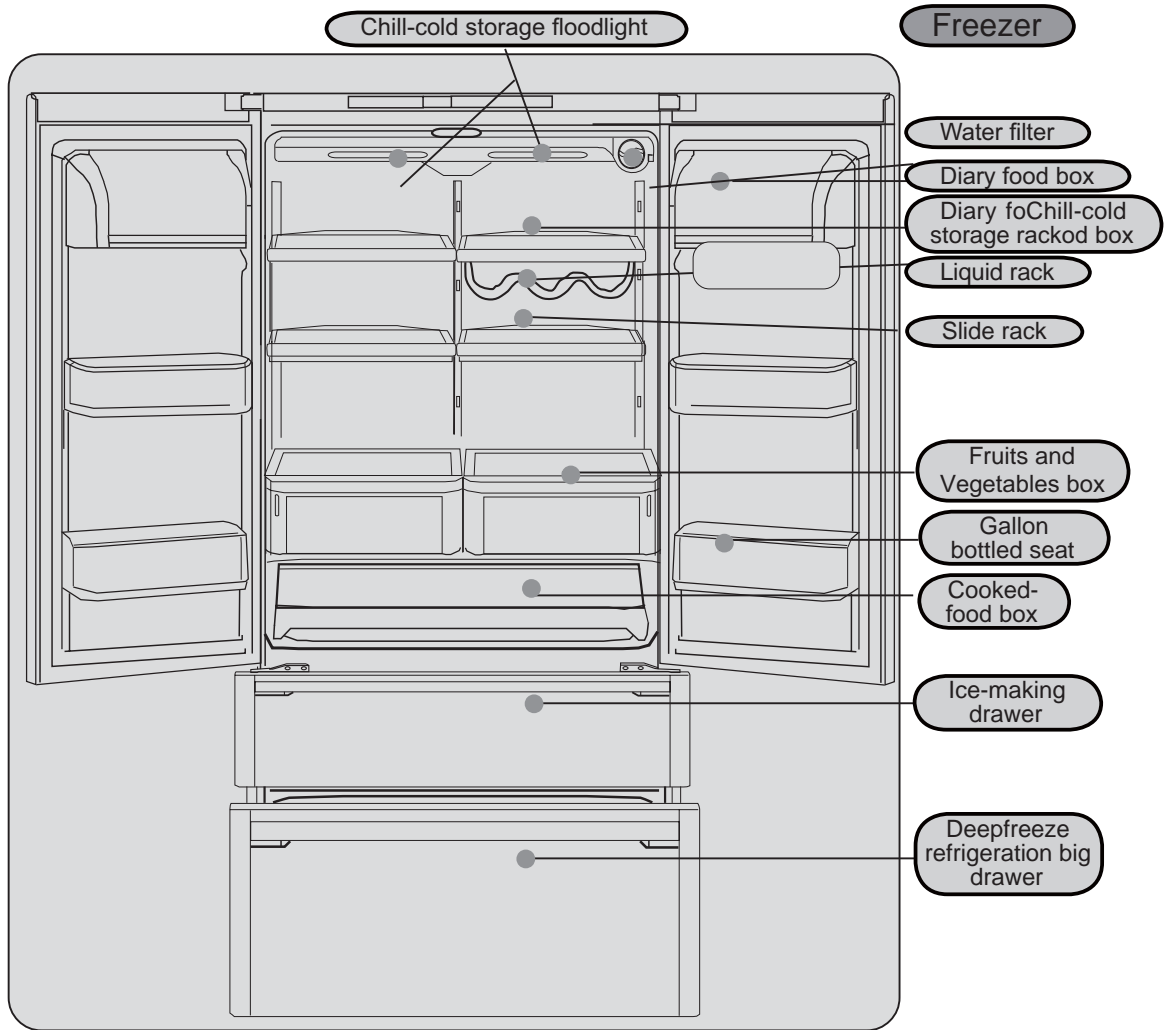

Note For the application of this brochure to different models, the characteristics of the refrigerator you are using may be different from the descriptions in this brochure.

DISASSEMBLY

1. Removing and replacing the right door of refrigerator compartment

① Unscrew the upper right hinge cover by means of screwdriver and then remove the hinge cover.

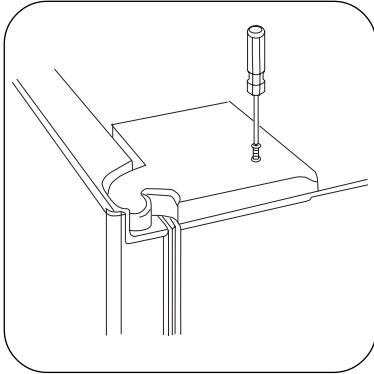

② Unscrew the upper right hinge by means of hexagonal screwdriver and then remove the hinge.

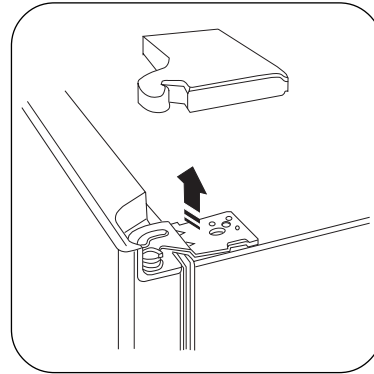

③ Remove the door and place it in a proper position.

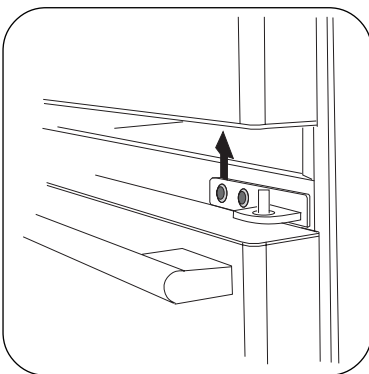

④ Remove the middle hinge if necessary.

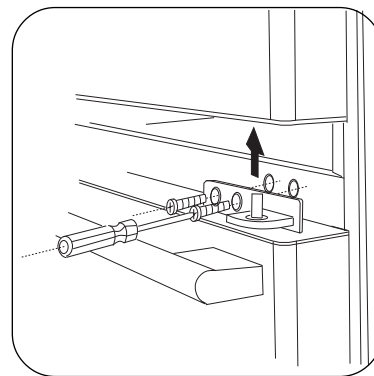

2. Removing and replacing the left door of refrigerator compartment

① Unscrew the upper left hinge cover by means of screwdriver and then remove the hinge cover.

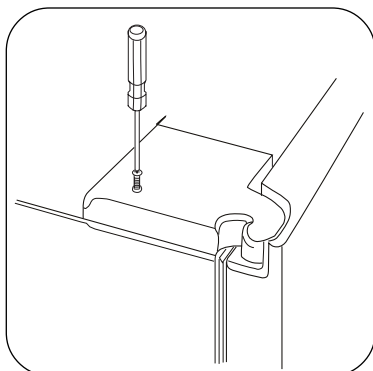

② Unscrew the upper left hinge by means of hexagonal screwdriver and then remove the hinge.

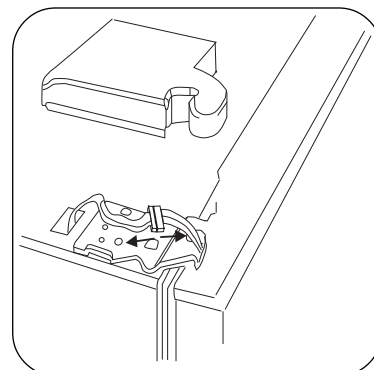

CONTROL AND DISPLAY SYSTEM

The door body vision controlling screen(just for PBFS21/PRFS25 series)

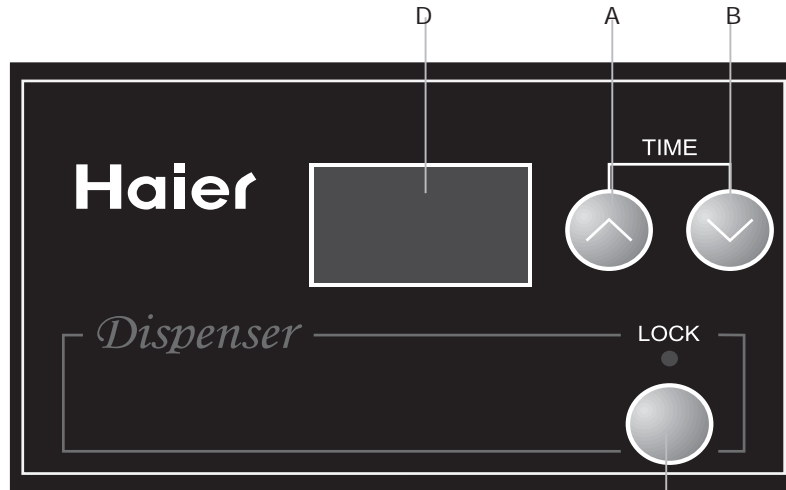

- AHour Button
- BMinute Button
- C..... Lock Button
- D..... Time Area

Function adjustment and control principle

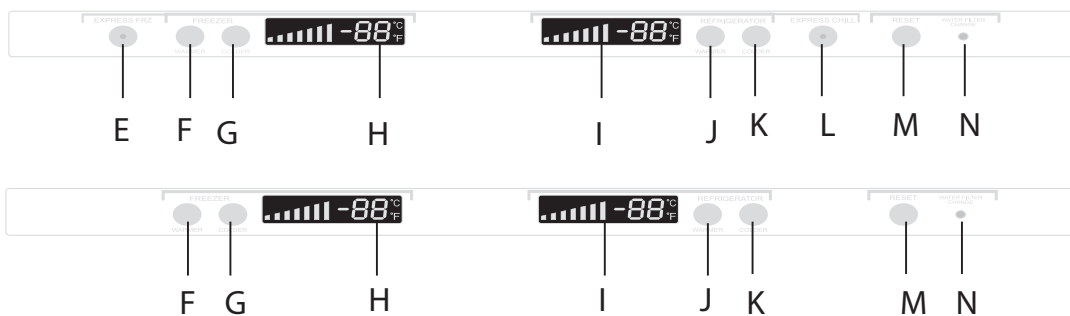

- EQuick-refrigerant button
- Hdeepfreeze fridge temperature indicating area
- J,K.....chill-cold storage temperature adjusting button
- M.....Water filter reset button
- F, G.....Deepfreeze fridge temperature adjusting button
- I.....Chill-cold storage temperature indicating area
- L.....Chill-cold storage quick-deepfreeze fridge
- N.....Water filter indicating lamp

CONTROL AND DISPLAY SYSTEM

1. Lock and Unlock (just for PBFS21/PRFS25 Series)

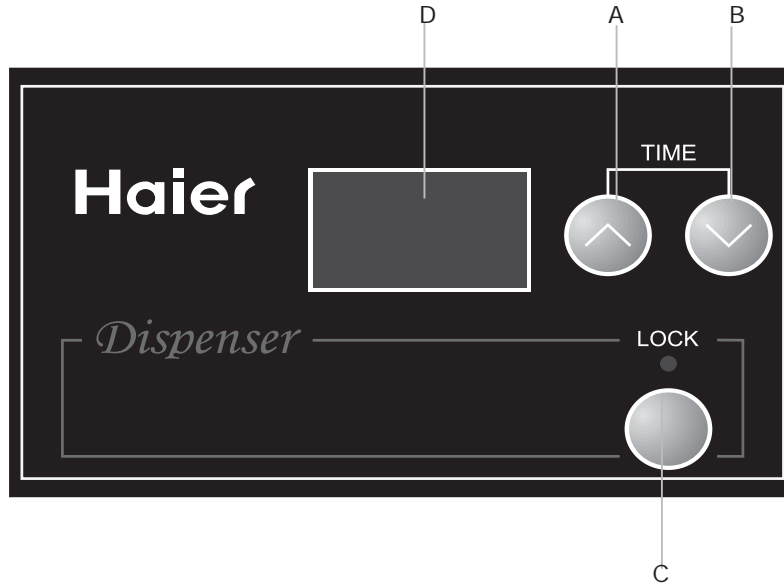

Press Button C, after the first sound of the buzzer, fix the indicating lamp to be lighted, and the clock setting of the door body vision cannot be operated, and the function of taking out cold drinks is locked; press Button C again, after the first sound of the buzzer, fix the indicating lamp to be out, and the clock setting of the door body vision operation is recovered.

2. Chill-cold storage temperature adjustment

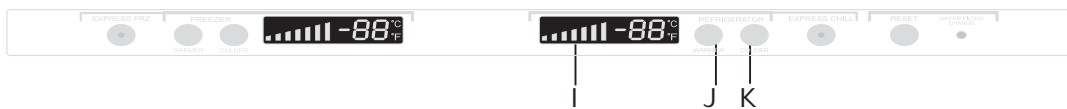

(Only apply for the models with the function of taking out cold drinks)



(Only apply for the models without the function of taking out cold drinks)

Press Button J or Button K, the chill-cold storage temperature vision area will flicker, and when the chill-cold storage temperature is set, the range of the chill-cold storage temperature is 34 degrees to 46 degrees, and each time you press Button K, the chill-cold storage temperature will increase a level, till the highest Level Seven is reached; each time you press Button J, the chill-cold storage temperature will decrease a level, till the lowest Level One is reached.

CONTROL AND DISPLAY SYSTEM

3. Deepfreeze fridge temperature adjustment



(Only apply for the models with the function of taking out cold drinks)



(Only apply for the models without the function of taking out cold drinks)

Press Button G or Button H, the deepfreeze fridge temperature vision area H will flicker, and when the deepfreeze fridge temperature is set, the range of the deepfreeze fridge temperature is -7 degrees to 8 degrees, and each time you press Button G, the deepfreeze fridge temperature will increase a level, till the highest Level Seven is reached; each time you press Button F, the deepfreeze fridge temperature will decrease a level, till the lowest Level One is reached.

4. Door body vision time adjustment (just for PBFS21/PRFS25 series)

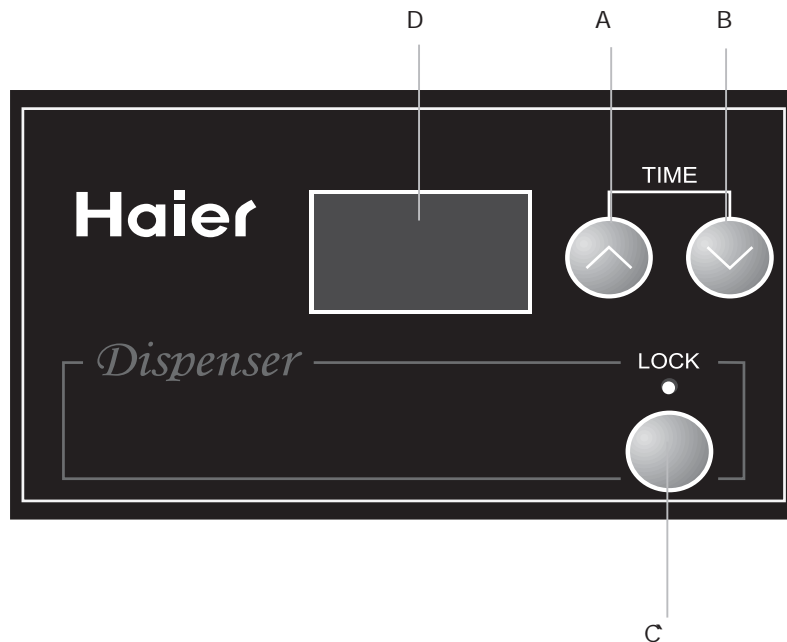

When pressing Button A and Button B at the same time for three seconds, the time sign D will begin to flicker after the first sound of the buzzer. Press Button A to adjust the hours, each time you press Button A, one hour will be increased, till 23 hours is reached, then press Button A again, 00 will be shown. Press Button B to adjust the minutes, each time you press Button B, one minute will be increased, till 59 minutes is reached, then press Button B again, 00 will be shown.

CONTROL AND DISPLAY SYSTEM

5. Refrigerant quick-deepfreeze refrigeration setting



The function of quick-deepfreeze refrigeration is to refrigerate the food completely in the shortest time. Press Button E, the refrigerant quick-deepfreeze refrigeration button indicating lamp will be lighted, and the refrigerator will be in the refrigerant quick-deepfreeze refrigeration state, and the refrigerator will be out of the refrigerant quick-deepfreeze refrigeration state after it enters the refrigerant quick-deepfreeze refrigeration state for 4 hours; if you want the refrigerator to be out of the refrigerant quick-deepfreeze refrigeration state forcefully after it enters the refrigerant quick-deepfreeze refrigeration state for three hours, you can press Button E again, and the refrigerant quick-deepfreeze refrigeration button indicating lamp will be out, and the refrigerator will be out of the refrigerant quick-deepfreeze refrigeration state.

6. Chill-cold storage quick-deepfreeze refrigeration setting



Press Button L, the chill-cold storage quick-deepfreeze refrigeration button indicating lamp will be lighted, and the refrigerator will be in the chill-cold storage chill-cold storage quick -deepfreeze refrigeration state, and the refrigerator will be out of the chill-cold storage quick -deepfreeze refrigeration state if the chill-cold storage temperature is 2 F lower than its designed temperature; if you want the refrigerator to be out of the chill-cold storage quick -deepfreeze refrigeration state, you can press Button L, and the chill-cold storage quick -deepfreeze refrigeration button indicating lamp will be out, and the refrigerator will be out of the chill-cold storage quick -deepfreeze refrigeration state.



Note

When the refrigerator is in the refrigerant quick-deepfreeze refrigeration state and in the chill-cold storage quick -deepfreeze refrigeration state, within the set time, the process of refrigerating remain constant without turning off the machine.

CONTROL AND DISPLAY SYSTEM

10. The function of showing and controlling

30 seconds after Operating the refrigerator by pressing the button, the vision screen is out automatically, and if you press any button or open any door or take out the cold drink, the vision screen will be shown to be on.

11. Exceptions Indicating

When exceptions on the main controlling function of the refrigerator happen, the exceptions signs will appear on the vision areas of the chill-cold storage or refrigerant temperature, and the exceptions signs are: F1, F2, F3, F5, F6, Ed, ER, E0, EI, E2.If this case really happens, please consult the sold-repairing department to have the refrigerator repaired, in order to test the optimizing controlling of the refrigerator.

12. Door-opening alarm

When any door body is opened for over 60 seconds, the door-opening alarming function of the refrigerator will be started, and the refrigerator will produce buzzers at the intervals of 30 seconds, which shows to the user that there is a door body is open.

13. Power-breaking memorizing function

When the refrigerator is cut off, the state of the refrigerator before the power-breaking is memorized, and then the refrigerator will be operating with the default values before power-breaking.

REFRIGERATION PRINCIPLE

SYSTEM FLOW CHART

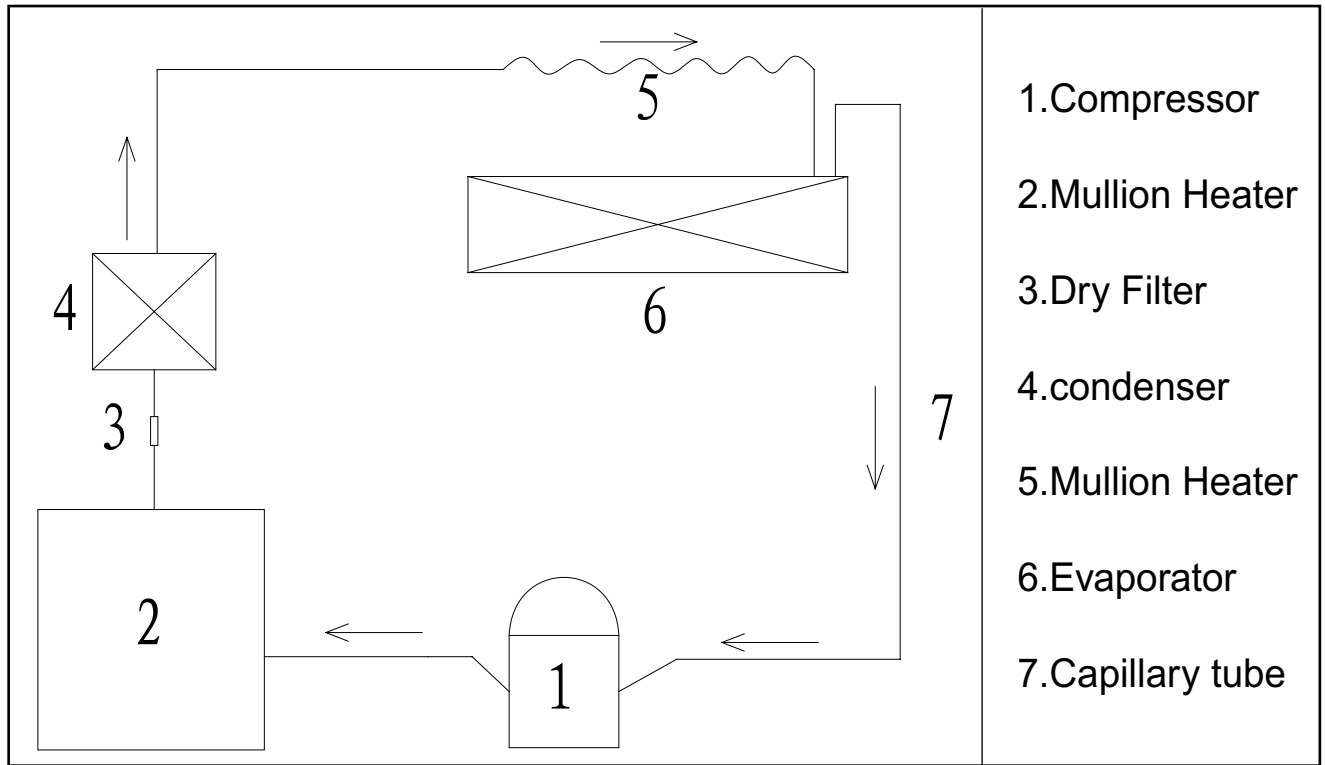

SYSTEM FLOW SCENOGRAPH

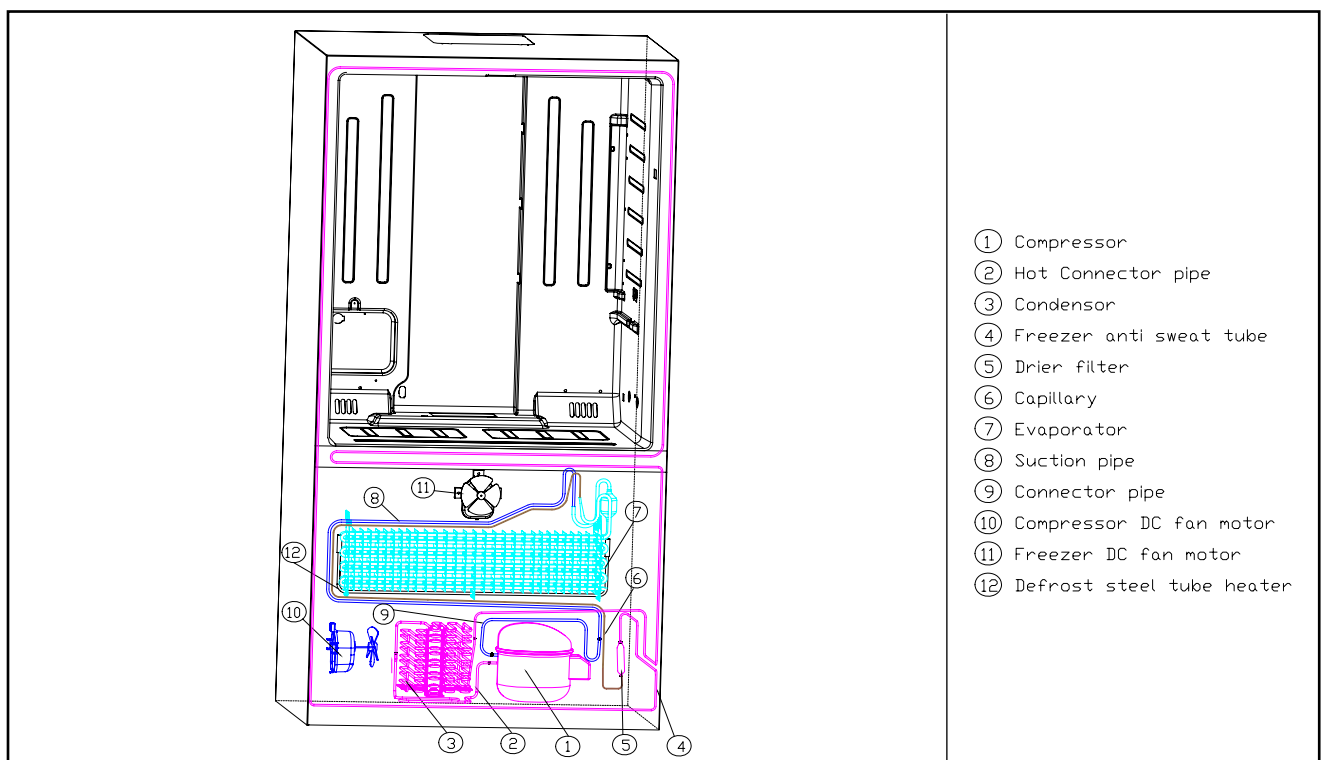

CIRCUIT DIAGRAM

1.Schematic

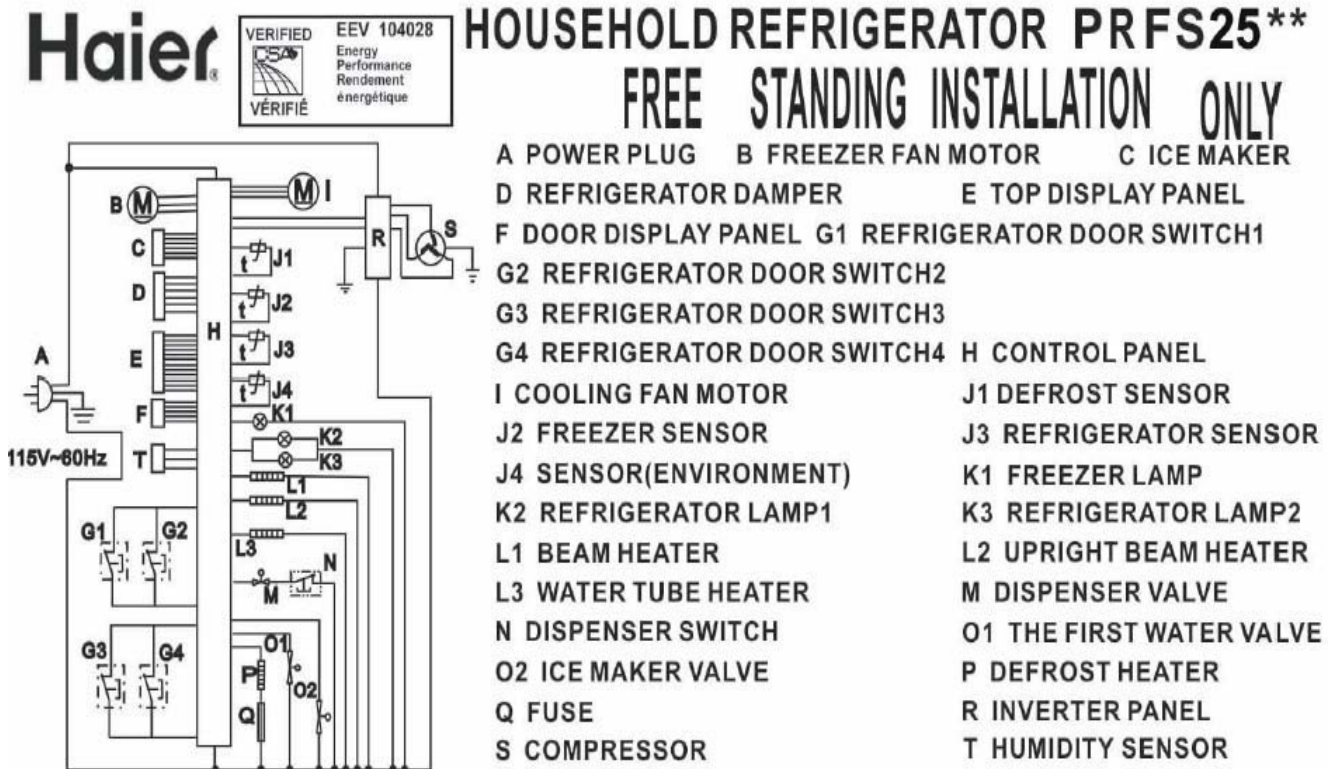

2. Connect diagram(for PRFS25EDA* series)

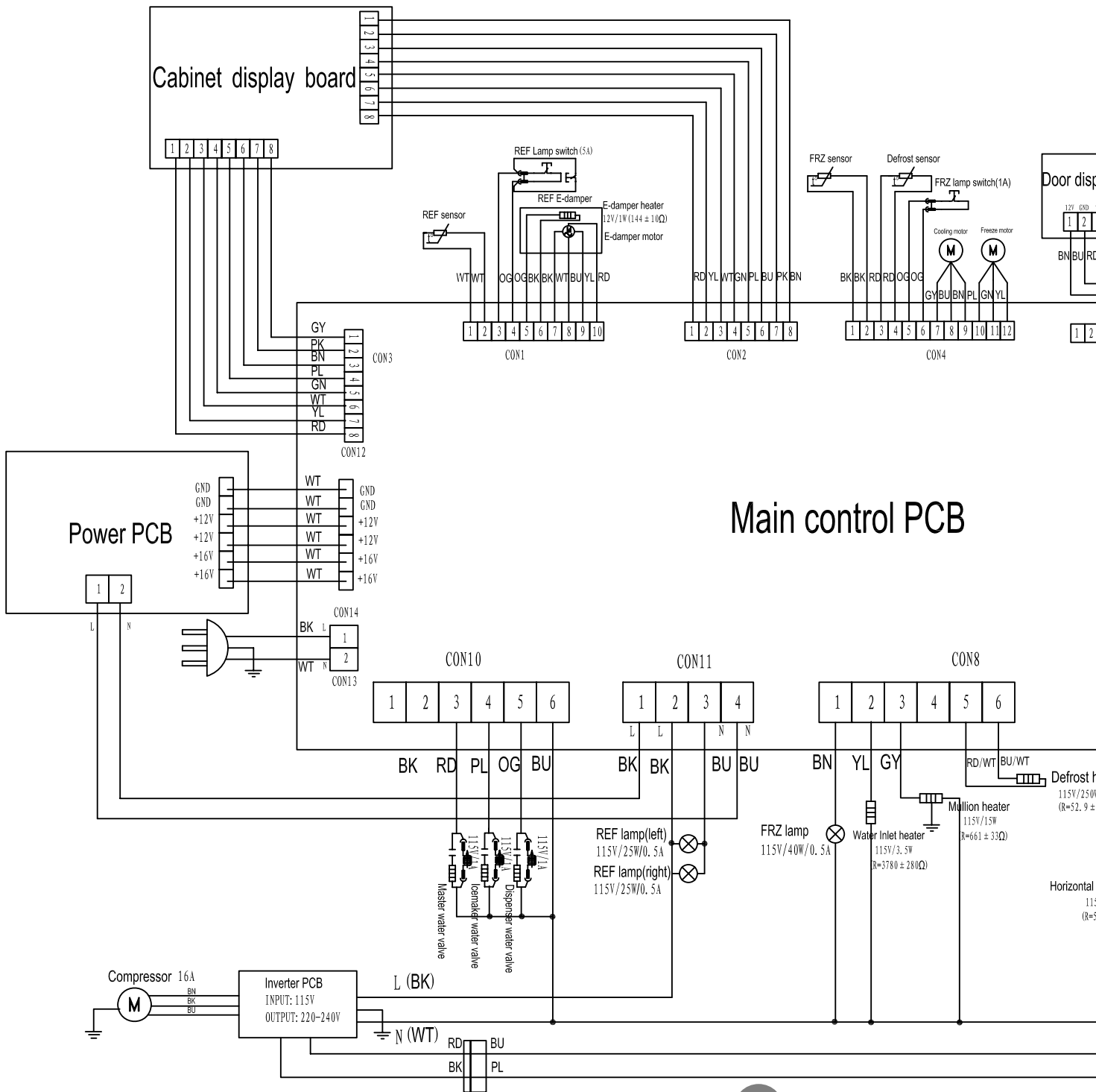

Mother Board Wiring Connections

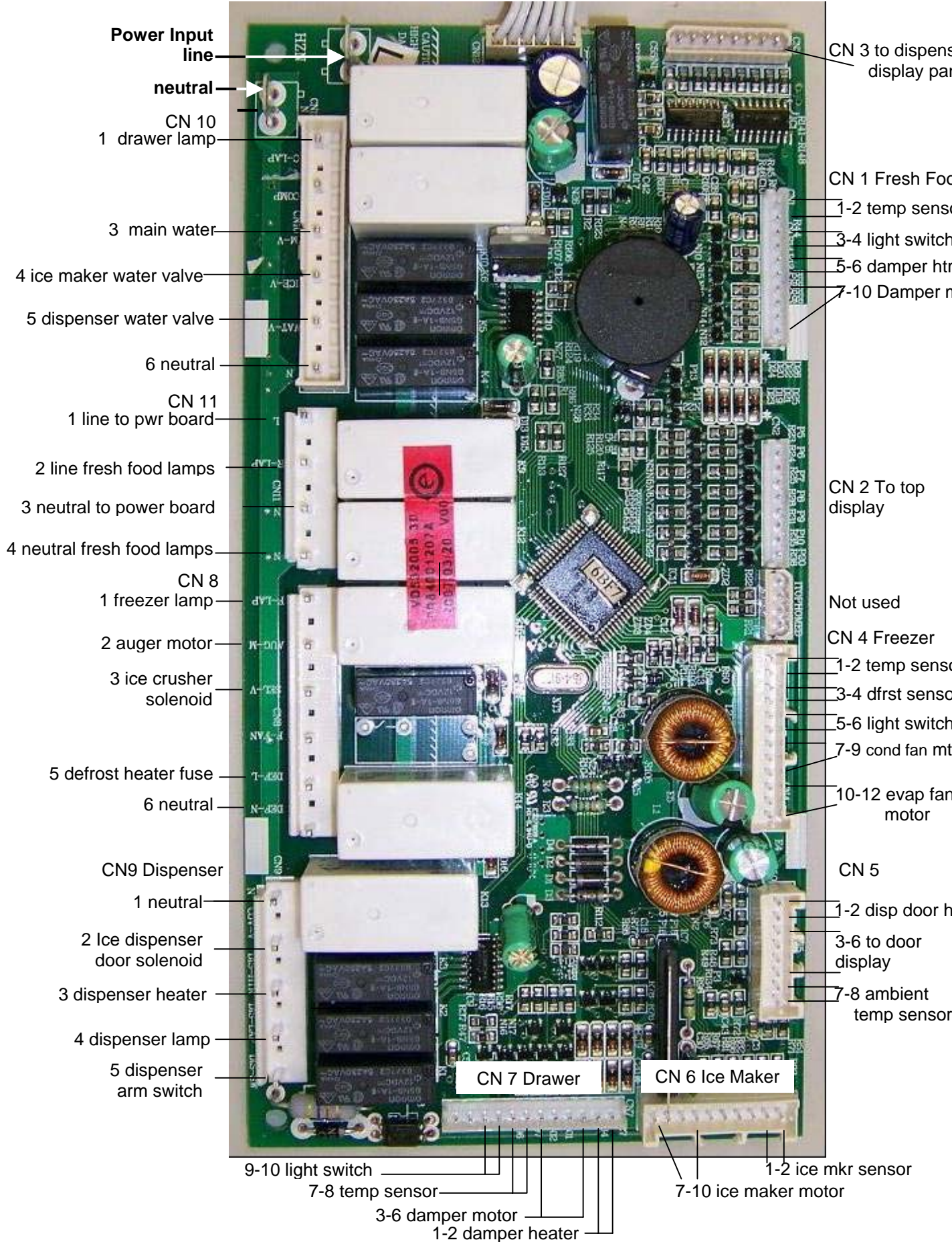

SENSOR AND ERROR CODE

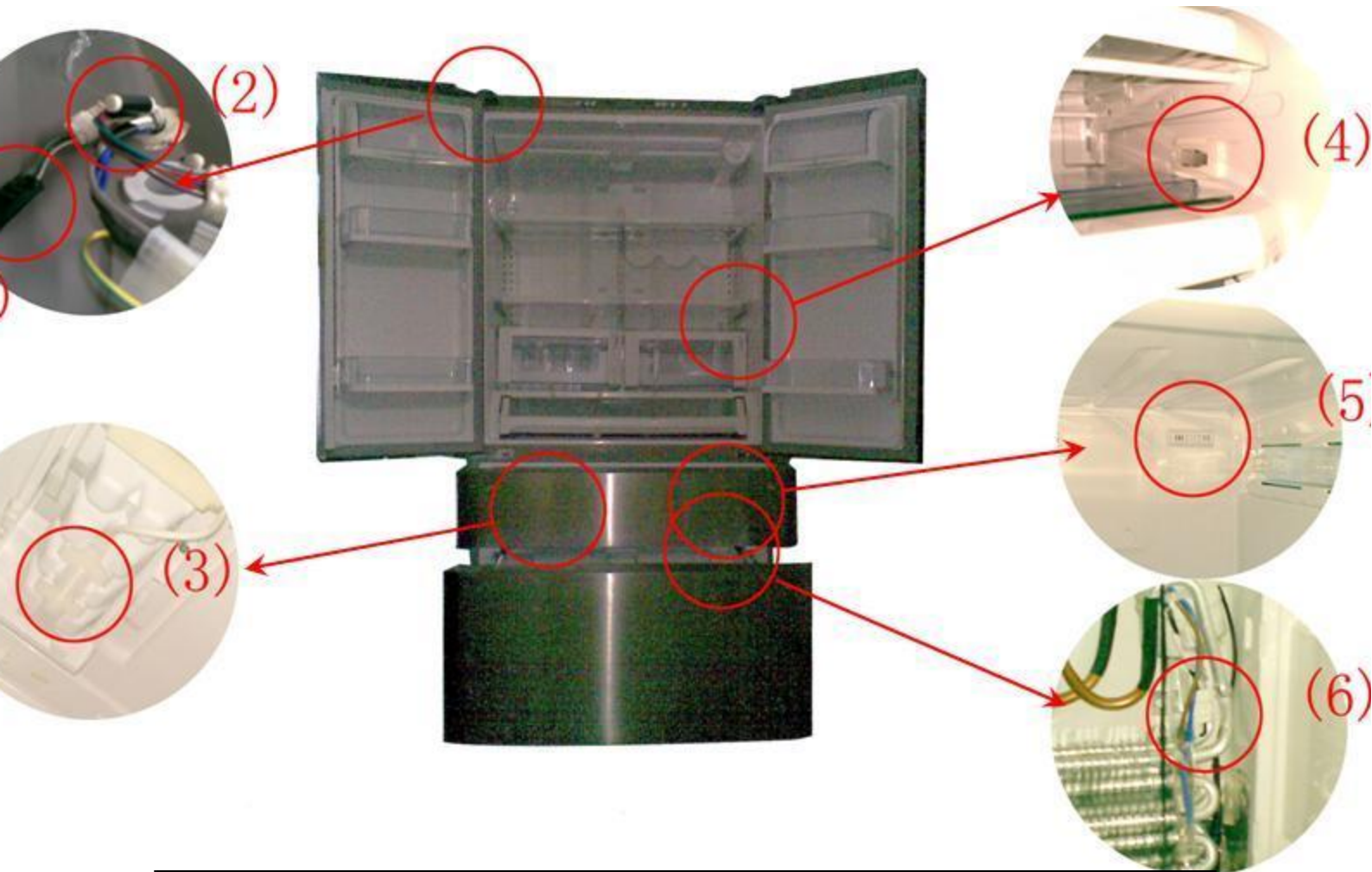

Error Code	Sensor	Location
F1	REF sensor	Right side wall of Fresh food compartment
F2	FRZ sensor	Back side wall of Freezer compartment
F3	Ambient sensor(rounded)	Under upper hinge(left) cover
F5	Defrost sensor	Top right corner evaporator
F6	Icemaker sensor	Icemaker flex tray
Eh	Humidity sensor(cubic)	Under upper hinge(left) cover

Centigrade(°C)	REF sensor/Ambient sensor(KΩ)	FRZ sensor/Icemaker sensor/Defrost sensor(KΩ)	Fahrenheit(°F)
-20°C	18.5	18.9	-4
-15°C	14	14.3	5
-10°C	10.68	10.9	14
-5°C	8.204	8.373	23
0°C	6.35	6.48	32
5°C	4.951	5.051	41
10°C	3.887	3.965	50
15°C	3.073	3.134	59
20°C	2.446	2.493	68
25°C	1.96	1.977	77
30°C	1.58	1.609	86
35°C	1.281	1.304	95
40°C	1.046	1.064	104

TROUBLESHOOTING

1. Analysis of Troubles and Troubleshooting

A. Poor Refrigerating Effect

The so-called “poor refrigerating effect “ refers to the fact that the refrigerator can operate and refrigerator normally, but the temperature in the refrigerator cannot drop to the prescribed value under the stipulated working conditions. In view of there are many causes for this phenomenon, we are going to discuss and analyze it in the following 7 aspects:

1) Leakage of refrigerant

Analysis of Trouble

The leakage of refrigerant in the system will result in an insufficient refrigerating capacity, the resulting phenomena are its lower gas suction pressure and exhaust pressure as well as higher exhaust gas temperature. The exhaust tube feels rather hot, and a continuous gas flowing sound louder than usual can be heard at the outlet of the capillary, and no frost or a smaller quantity of loose frost appears on the evaporator. After shut down, the balance pressure in the system is usually lower than the saturation pressure corresponding to the same ambient temperature.

Remedy

In case there is leakage of refrigerant from the system, do not hurry to recharge it with refrigerant, manage to find out leak points immediately, and make a note of from where it leaks ---welding points and parts. After having them repaired, recharge refrigerant.

There are so many joints and sealed surfaces in a refrigerator, accordingly, quite a lot potential leak points do exist in the system. In troubleshooting, pay attention to those parts that are liable to leak, check main connection points for oil seepage and tubing for cracks. If there is no severer leak point, charge the system with nitrogen and detect leak points with the commonly adopted method, repair them, evacuate, charge the system with refrigerant, and then turn on the refrigerator to make a test run.

2) Too much refrigerant charged into the system

Analysis of Trouble

a) In case the amount of refrigerant charged into the system exceeds its nominal capacity, the superfluous refrigerant will of course take some space of the evaporator, thus reducing its heat-dissipation area and hence the refrigerating efficiency of the system. The abnormal phenomena caused by this reason are as follows: the gas suction and exhaust pressures are generally higher than their respective normal values, the temperature of its condenser is higher and the electric current of the compressor rises, loose frost forms on the evaporator, the refrigerator temperature drops slowly, and frost appears on the gas return tube .

b) In case excessive refrigerant has been charged, the liquid refrigerant that can not evaporates in the evaporator will return to the compressor, and thus a phenomenon of “liquid striking” will occur. The liquid refrigerant evaporates and effervesces as soon as it flows into the refrigerating oil at the bottom of compressor .If the condition is severe, foams will fill all over inside the compressor housing and be sucked by the piston, causing damage to the components of compressor.

Remedy

According to the operating procedures, it is mandatory to turn the machine off, and several minutes later, open the refrigerant charging tube and let the refrigerant escape from it, replace the dry filter, recharge refrigerant after evacuating, and then seal the charging port.

3) There is air left in the refrigerating system

Analysis of Trouble

Residual air in the refrigerating system will reduce its refrigerating efficiency. The prominent phenomena are the increase in its gas suction and exhaust pressures (however, the gas exhaust pressure will not exceed its rated value), obvious increase in temperature in the segment from the compressor outlet to the condenser inlet. Because there is air in the system, both the gas exhaust pressure and temperature will rise, and moreover, the gas flowing sound is intermittent and obviously louder.

Remedy

After shut down for several minutes, open the tubing, evacuate it and then recharge the system with refrigerant.

4) Low efficiency of compressor

Analysis of Trouble

Low efficiency of a refrigerating compressor refers to the actual reduction of gas discharge capacity, and hence the corresponding reduction of refrigerating capacity, under the condition that the refrigerant in the system is unchanged. This phenomenon occurs mostly when the compressor has been used for quite a long time, its moving parts have worn to a considerable degree, fit clearance between various parts have increased and sealing property of its gas valve has deteriorated, resulting in an decrease in its actual gas discharge capacity.

Methods of Judgment

Measure the high and low pressures with pressure gauges to see whether they are normal. If an abnormal sound comes from the compressor or the temperature of its causing is too high, cut the discharge port open and operate the compressor, feel it if there is pressure at the discharge port with your finger (For a normal compressor, its discharge port is difficult to be blocked with your finger if you just apply a little effort).

5) Refrigerating oil left in evaporator tubing

Analysis of Trouble

During the process of refrigerating cycles, a little refrigerating oil may remain in the evaporator tubing, and after a longer time of operation, if there is considerable refrigerating oil left in the evaporator, the heat conduction effect will be severely affected, thus causing a poor refrigerating effect.

Remedy

It is quite difficult to determine whether this trouble is caused by the refrigerating oil left in the evaporator tubing, because this kind of phenomenon and other several trouble are tends to be

confused. Generally speaking, you can make a judgment based on the frost formed on the evaporator. If the frost does not cover the evaporator, and moreover, it is loosely formed, you can make a judgment that the deterioration of refrigerating effect is due to the accumulation of refrigerating oil left in the evaporator tubing in case no other troubles have been found. To clear off refrigerating oil left in the evaporator, dismantle the evaporator, purge it thoroughly and then dry it. In case it is difficult to dismantle it, charge refrigerant from the evaporator inlet to wash it several times, then purge and dry it with nitrogen.

6) Flowing obstructed in refrigerating system

Analysis of Trouble

Because the refrigerating system was originally not purged thoroughly, some of the filter screen meshes have been clogged by dirt accumulated in the filter after using it for a certain time of period, thus resulting in a decrease in flow rate, and hence a poorer refrigerating effect. The abnormal phenomena caused by this kind of slight clogging in the system are as follows: the gas discharge pressure is lower, the temperature of discharged gas drops down, the position clogged has a temperature lower than that in normal conditions, and for a severe clogging, even dew condensation as frosting may appear.

Remedy

Purge the tubing, and after replacing the dry filter with a new one or clearing it thoroughly, recharge the system with refrigerant and seal the charging port.

B. No Refrigerating

The phenomenon that the compressor runs normally, but no frost (or only a little frost) appears on the evaporator, and the refrigerator temperature does not drop down is called “no refrigerating”. There are many causes for this trouble and it is relatively complicated, too. In servicing, special attention to finding direct causes for this phenomenon. Three main potential causes for this trouble are analyzed below:

1) All refrigerant in the system has leaked out

Analysis of Trouble

Leak points in the refrigerating system have not been found and repaired timely, thus resulting in the total escape of refrigerant. There are two kinds of leakage: I) slow leakage for instance, when we want to use a refrigerator that has been put out of quite a long time, we find the leakage of refrigerant, or in the course of its operation, we have found that the refrigerator is gradually becoming not so cold and finally no refrigerating can be achieved; ii) fast leakage in that case, all the refrigerant will escape swiftly due to abrupt rupture of system tubing.

Symptoms of total leakage of refrigerant are mainly as follows: the compressor can be started easily (if there is no damage to the compressor parts) and its operating current becomes low, its gas suction pressure is high and discharge pressure is lower, the gas discharge tube feels rather cold, no sound of gas eruption from the liquid in the evaporator can be heard, and no will gush out of the process tube if you cut it open after shutdown.

Remedy

Check the whole machine, particularly those locations, which are liable to leak. After leak points have been found, repair them or replace them with new parts according to specific circumstances, then evacuate the system and finally charge refrigerant.

2) Refrigerating system has been clogged

a) Clogged with Ice

Analysis of Trouble

The dryness treatment for the major parts in the refrigerating system has been performed improperly, the effect of air purging for the whole system is not good, or the water content in the refrigerant is out of standard, all these will cause the expansion valve to be clogged with ice. The symptom for this trouble are as follows: the refrigerator sometimes can refrigerate and sometimes cannot: the refrigerator compartment works normally at the beginning, but after working for a certain period of time, frosting begins at the clogged position, evaporation temperature reaches below 0°C, water will accumulate at the narrow part of the capillary and clog it gradually, then frost begins to melt at the evaporator, no gas flowing sound can be heard, and the gas suction pressure assumes a state of vacuum. Note that these phenomena will appear intermittently; sometimes, the refrigerator works well, and sometimes not well. In order to determine whether it is clogged with ice, heat the suspicious points with hot water to make ice melt, and after a while if a gas flowing sound resulting from an abrupt gush is heard and the gas suction pressure rises as well, it can be confirmed that the trouble is caused by ice clogging.

Remedy

If there is too much moisture in the refrigerating system, it is advisable to release the refrigerant, purge the tubing with nitrogen, and then charge the system with the filtered refrigerant. However, the commonly adopted method is to connect a filter with moisture absorbers (such as silica-gel, anhydrous calcium chloride) to the refrigerating system so as to filter out the moisture from the system, then replace the filter, evacuate it again and finally charge the system with refrigerant.

b) Clogged with dirt in capillary

Analysis of Trouble

The capillary inlet is a place where coarse-grained dirt or refrigerant oil in the system will tend to settle down and clog it. In case considerable dirt accumulates there, the whole filter screen may be blocked totally, making the refrigerant unable to go through. Clogging with dirt exhibits the same symptoms as that with ice, namely, higher gas suction pressure, lower temperature of discharged gas, and no gas flowing sound from the evaporator. The difference between the both is as follows: if the clogging is caused by dirt, tapping the suspicious clogged point (generally in the capillary or the connection joint of the filter) may cause the refrigerant to flow through partially, resulting in some corresponding change, whereas in that case if you heat it with a hot towel, no reaction will happen, no flowing sound can be heard, moreover, there is no periodic change. After rejecting the possibility of ice clogging, it can be generally considered as the clogging due to dirt.

Remedy

Dismantle the system, remove the dry filter from it, purge the tubing with nitrogen, install a new filter, then evacuate it and finally charge it with refrigerant.

C) Clogging in filter

Analysis of Trouble

Total clogging of a filter is rarely to occur. The paste-like matter formed from the substances filled into the system mostly causes this trouble or other dust after the refrigerator has been used for a longer time, or by the dirt accumulated gradually inside the filter. Sometimes, tapping the filter may cause a passage for flowing, Touching it with your hand, you will feel that it is cooler compared with its temperature in the normal state.

Remedy

The same as described in the capillary clogging with dirt.

3) Troubles of Compressor

a) Breakage of gas suction and discharge valve blocks

Analysis of Trouble

The compressor works by means of the opening and closing of gas suction valve and discharge valve to suck and discharge the refrigerant. If the valve block is broken, the refrigerant can not be discharged, and hence no refrigerating can be achieved.

Method for making judgement

It is quite difficult to differentiate this trouble from others because they often have similar symptoms. In repairing, firstly, hear attentively if there is some abnormal sound coming from the compressor (sometimes, the broken pieces of valve block may strike against the cylinder), and feel the compressor casing with your hand to ascertain whether it is too hot, this is also helpful to the troubleshooting; secondly, measure the pressures at the high and low pressure ports of the compressor with pressure gauges, if the gas suction valve block is broken, the suction pressure gauge pointer will swing violently and the suction pressure is very high, whereas when the gas discharge valve block is broken, the discharge pressure gauge pointer will swing drastically and the discharge pressure is very high. In the both cases, stop the compressor at once, and if technique is available, open the cylinder cover and check up the valve block, repair it, or replace it with a new one,

C. Sudden stop of Compressor during Its Running

The cause of sudden stop of a compressor during its running is mostly that the gas suction pressure and/or discharge pressure exceed their respective prescribed ranges, thus making a pressure-operated protective relay shut off the power to the compressor and stop it. In the following we discuss mainly the reasons for causing excessively high gas discharge pressure and low suction pressure.

1) Stoppage due to excessively high gas discharge pressure

A) Too much refrigerant charged into the system

Analysis of Trouble

The phenomenon, such as loose frosting and poor refrigerating effect, may occur if excessive refrigerant has been charged into the system. Superfluous refrigerant will occupy a certain space of the evaporator, thus reduce its heat dissipating area, and the phenomenon of “liquid striking” may occur, too. Meanwhile, dew or frost condensation may occur on the gas return tube, and the gas discharge pressure will obviously rise, when it reaches the threshold value, the protective relay will actuate and shut off the power supply to the compressor.

Remedy

Open the tubing, re-evacuate and then charge the system with a proper quantity of refrigerant.

b) Air left in the system

Analysis of Trouble

The residual air in the system will circulate together with the refrigerant in the system. The major symptoms caused by this residual air is higher gas discharge pressure, higher discharged gas temperature (the gas discharge tubing is considerably hot when you feel it with your hand), and poorer refrigerating effect. Furthermore, the gas discharge pressure will exceed its normal value when the compressor has run for a period not too long, thus making the protective relay actuate and bring to a stoppage.

Remedy

Check up how the air has been left in the refrigerating system. Generally, there are two possibilities: one is that the air has been sucked into the system when repairing due to carelessness, or it has not been purged out totally when evacuating the system; the other is that there are leak points at the low pressure end of the refrigerating system. Leak points appear mostly in those low temperature parts or assemblies, because the evaporation temperature is lower for such low temperature devices, especially at the low pressure end, it is easier for the air goes into the system. Once it has been ascertained that air does exist in the system, you have to open the tubing, re-evacuate it and then charge it with refrigerant.

2) Stoppage due to electric troubles

a) Thermostat is out of control

Analysis of Trouble

In case the thermostat does not work in its good order or its temperature sensor has not been installed properly, frequent stoppage is also likely to occur.

Remedy

Try to adjust the temperature sensor’s position until the compressor can be started and stopped normally. If this cannot be achieved, and the stoppage still occurs repeatedly, it is most likely that the mechanical parts or contacts are out of order, disassemble the thermostat, make a thorough checkup and repair it.

b) Overload of electric motor

Analysis of Trouble

Probably, too many things have been put into the refrigerator, and hence the thermal load exceeds its refrigerating capacity; or in case the power supply voltage drops considerably, the current flowing through the motor will increase drastically making the thermal protector actuate and the fuse blown, and hence the motor stops running. If the motor is still running continuously in such a case, its windings will be burned out.

Remedy

Reduce the thermal load; pay attention to the variation in voltage of the power supply.

c) Abnormal thermal protection

Analysis of Trouble

The compressor current is within its normal range, but the thermal protector actuates repeatedly.

Remedy

Replace the thermal protector with a new one.

3) Sudden stoppage due to other causes

Normal Stoppage

A thermostat generally controls start and stop of the compressor. When the temperature in the refrigerator reaches its desired value, the thermostat will shut down the compressor automatically. Never take this normal operation as a trouble, care should be taken to differentiate it from other real troubles in servicing.

D. Compressor won 't start

In case the compressor cannot be started, you must find out the origins of this trouble through checkup step by step, because probably there are many causes, including those electrical and mechanical.

1) Inspect the power supply to see whether it is connected to the compressor circuit.

Analysis of Trouble

In case the compressor cannot be started, this will generally exhibit in the power supply circuit, for instance, power failure, poor contact of switch, and blown fuse. Make a comprehensive analysis of these phenomena, find out its real cause and take correct measures to remove this trouble.

Remedy

a) Check the input power circuit to see whether where is voltage of the power supplies, namely, the circuit which is connected to the knife switch. This can be determined with an avometer or a test pencil. If a blown fuse is found, ascertain and remove its cause, then replace it with a new one of the same specifications.

b) Check the compressor accessories, including its thermal protector and relay. In case the thermal protector is damaged, the compressor cannot be powered on. If the relay is out of order, the motor will not run and hum sound can be heard from it after the compressor is turned on, in that case, shut it down immediately, otherwise, the motor windings will be burned out in case this condition lasts longer.

c) Check the relay contacts and plugs to see if they are perfect and work reliably. Poor contact may cause the motor not running or humming.

2) Check the circuit voltage to see whether it is normal.

Analysis of trouble

If the circuit voltage is obviously lower than its rated value, it will be difficult to start the motor, and a hum sound can be heard from it.

Remedy

Measures the voltage with a voltmeter, if it is really too low, give directions to the user for buying a stabilizer so as to step up the voltage, thus normal operation can be achieved.

3) Check the thermal relay to see whether its contacts are closed.

Analysis of Trouble

The contacts of thermal relay sometimes may be open due to the leakage of temperature sensing agent from the temperature sensor.

Remedy

Remove the relay cover to check up its contacts, if they are open, this means that the original setting is not properly set or temperature sensing agent has leaked out of the temperature sensor. Try to turn the adjusting stem of this value in the direction of the lower temperature graduation, then check the contacts to see whether they are closed. If they are still not closed, dismantle the temperature sensing disc and then immerse it into warm water to see whether the contacts actuate, if not, it can be preliminarily determine that temperature sensing agent has leaked out, and it must be replaced with a new thermostat.

4) Motor troubles and other electric faults

a) Motor windings have been burned or short-circuited between turns

Analysis of Trouble

When motor windings have been burned or short-circuited between turns, the fuse will be blown repeatedly, and the blowout occurs particularly at the instant when you close the knife switch.

Remedy

Check the terminals and the outer casing to see whether they are short-circuited, and measure the resistance of each phase with an avometer. If short circuit occurs or the resistance of a

certain phase is low, this means that short circuit does exist in the windings and/or between turns, and insulation layers have been burned or deteriorated. A megametre can be used in this inspection, too. If the insulation resistance is lower than 2 MΩ, this means that the insulation layer is already breakdown. If the motor has been burned, repair it or replaced it with a new one.

b) Fault of control relay

Analysis of Trouble

Overheat, burnout or wear of control relay contacts may occur generally. All these will cause poor contact in electricity.

Remedy

Dismantle it to repair, or replace it with a new one.

c) Poor electric contractor in thermostat

Analysis of Trouble

Burnout of contractor and leakage of temperature sensing agent may occur generally.

Remedy

Replace the old with a new one.

d) Check the terminals for loose connection and electric circuits for other abnormal phenomena.

5) Mechanical faults of compressor

a) Seizing of shaft

This phenomenon is caused mostly by poor lubrication, such as insufficient quantity of lubricant, clogging in the lubricant oil line, or intermittent lubricant oil supply. Dirt and other impurities in the lubricant oil will increase its viscosity and cause the shaft to be seized. Copper plating may also result in seizing of shaft.

b) Seizing of piston

This is caused by too small fit clearance between the piston and cylinder or expansion due to heat.

Judgement of seizing shaft and piston: After the refrigerator has been powered on, the compressor will not start and run, but a slight hum sound can be heard, and several seconds later, thermal protective relay will actuate and make the contacts open; this process will occur repeatedly, but the compressor cannot be started.

E. Compressor won't stop

Sometimes, the compressor will run continuously (for several hours or run without end), If the food placed in the refrigerator is not too much, there may be the following two situations: i) the refrigerator very low, this means that the control system is probably out of order; ii) the control system works normally, and there are troubles in the refrigerating system or other parts.

1) Temperature is set improperly

- a) The temperature control knob is set to the “coldest” position. This position is to be used for fast freezing or continuous running, its temperature for power off is too low, therefore, the compressor won’t stop and the temperature in the refrigerator becomes lower and lowers.
- b) Inspection method: check the temperature control knob to see whether it is set in the position “coldest”.

2) Thermostat is malfunctioning and makes the compressor running continuously

Analysis of Trouble

When the thermostat doesn’t work normally, it will make the compressor run continuously, and hence very low temperature will be achieved in the refrigerator. The fault is generally due to the fact that the contacts of the thermostat cannot be released.

Remedy

Dismantle the thermostat and make a through checkup, if it is totally out of functioning, replace it with a new one.

3) evaporation temperature is too high in refrigerating system, resulting in lower refrigerating capacity and hence continuous running of compressor

Analysis of Trouble

Leakage of refrigerant and clogging in a refrigerating system will directly affect its refrigerating capacity. Due to the reduction in its refrigerating capacity, the refrigerator temperature cannot reach its rated value, the thermostat won’t work, and thus the compressor runs continuously. When the evaporation temperature in the system is too high, the temperature-sensing agent in the temperature sensor is also hotter, therefore, the thermostat is unable to cut off the power supply to the compressor and stop it.

Remedy

If it has been found that the refrigerant in the system is insufficient in quantity, recharge it with refrigerant. In case clogging occurs, disassemble the part where it is blocked. If the evaporation temperature is too high, settle this problem with an appropriate quantity of refrigerant.

4) No stoppage of compressor due to damaged heat-insulation layer inside case body and/or door seal

Analysis of Trouble

When the heat-insulation layer inside the case body deteriorates or the door seal is not closely touches the doorframe, the temperature in the refrigerator will rise and makes the compressor running continuously.

Remedy

Check the heat-insulation layer for its damaged parts; repair it to improve its heat-insulation property. If the door has deformed or the door seal is not tightly sealed against the case body, repair them, respectively.

- 5) Too much food is placed in the refrigerator, or is placed too densely, resulting in poor ventilation or poor conditions for temperature sensing, and hence no stoppage of the compressor.**
- 6) Too high ambient temperature, poorer ventilation and heat dissipation makes the compressor running without stop.**

F. Electric leakage of refrigerator

1) Slight electric leakage

Electric insulation has deteriorated due to being affected with damp, thus resulting in slight electric leakage.

2) Serious electric leakage

Refrigerator case has become live due to faults occurred in some electric devices or the erroneous wiring in installing power cord plug or outlet by the user. This is very dangerous.

3) Electric leakage test

a) Slight electric leakage

A tingle sense will be experienced as soon as you touch the metal parts of the refrigerator with your hand. When you test them with a test pencil, its neon lamp will come on .In that case, the first thing you need to do is to determine whether the grounding is perfect .If the grounding is no problem, turn off the refrigerator immediately, then check the insulation of electric circuits with an avometer.

b) Serious electric leakage

Never touch the case body of the refrigerator, its door handle or other metal parts with your hand. Test the refrigerator with a test pencil, it will light up intensively ;measure the resistance between the power cord plug and the case body with an avometer ,the reading will be zero (0Ω); in the worst case ,the fuse will be blown .Check the 3-prong outlet to see whether the live wire and the null line are inversely connected ,this makes the ground protection lead-out from the power cord plug being connected to the live wire .Another possibility is that the live wire and null line of the outdoor

power supply circuit have been inversely connected accordingly ,this makes the null line become a live wire .

G. Stronger vibration and loader noise

1) Refrigerator placed improperly

a) Uneven ground

Uneven ground will cause the refrigerator to be placed unsteadily, causing stronger vibration and noise during its operation.

b) Leveling screws not properly adjusted

If the leveling screws on refrigerator legs have not been adjusted properly, vibration and noise will still occur even if the refrigerator has been placed on a level ground.

2) Abnormal noise from compressor

Three suspended spring inside the compressor case are out of balance, and strike against the case, moreover, the wear of compressor parts may cause noise sometimes.

3) Resonance of tubing and loosening of parts

Improper and compact laying of tubes or the loosening of parts may cause vibration and noise.

4) Large noise of the fan

a)The fan motor is loose;

b)Noise is produced by normal operation of the fan.

c)The impellers are not tightly fixed or eccentrically assembled.

Remedy:







For reason a): Fasten the fan motor.

For reason b) or c): Replace the fan motor or impellers.

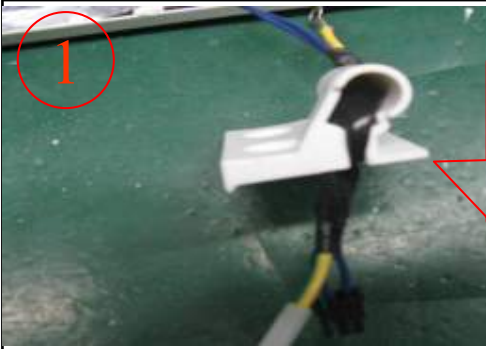
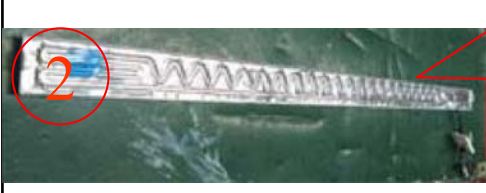
5)Inspection method



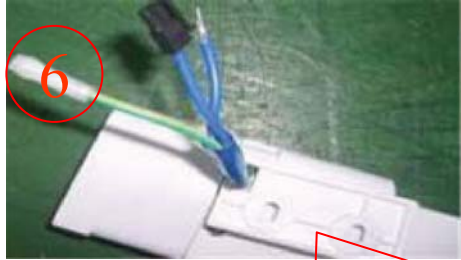

To find the sources of noise, press the vibration spot with your hand while the refrigerator is in operation and listen attentively whether the vibration becomes weaker or vanishes. If the refrigerator has not been levelly placed, put a level meter on its top table and adjust the leveling screws on its legs. In case noise occurs from the compressor, strike different locations on the side surface of its case using a rubber hammer or hand hammer with a wood block in-between so as to determine whether the suspended springs are out of balance or being seized.

Instruction of assembling Mullion on BM21

Instruction	
	<p>1. Install top axis of mullion through the heater;</p>
	<p>2. Paste the heater onto mullion;</p>
	<p>3. Fix the earth wire;</p>
	<p>4. Install the reinforce metal and foam on the bottom cover;</p>
	<p>5. Fix the bottom cover on the mullion, then fix the spring, bottom axis, foam airproof;</p>
	<p>6. Fix the top axis and top cover;</p>
	<p>7. Fix the 5 screws. Preinstall mullion is OK.</p>

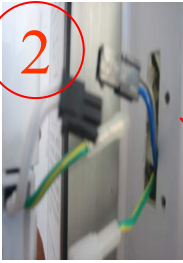
The b
the w
wire(



Instruction of replacing Mullion heater on BL

Instruction		
	1. Remove the screws on mullion;	
	3. Remove the screws on mullion;	
	4. Remove the upper cover, seal and bottom cover;	
	5. Remove the screw fixing earth wire;	
	6. Tear off the heater and replace a new one. Then install it according to the steps above.	

1. Be
will c
cover

2. A
5-10
mull
the c
nece

Instruction of replacing Horizontal Mullion

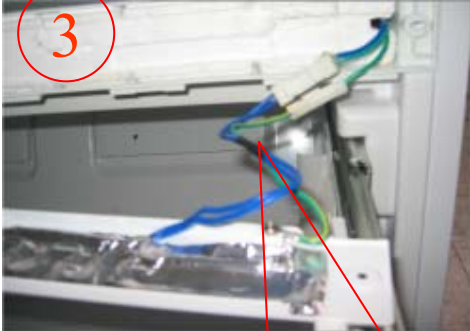
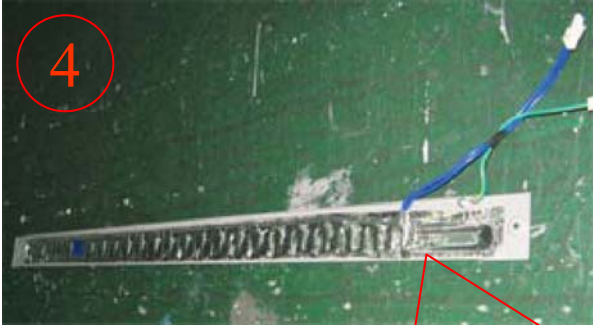
Instruction		
		1.Remove the screws fixing horizontal mullion;
		2.Dismantle the horizontal mullion and foam airproof;
		3.Disconnect the linking clip and mullion heater;
		4.Remove the screw fixing earth wire of heater,then tear off the heater;
5.Install the horizontal mullion according to the above steps.		

Instruction of removing FRZ sensor on BM2

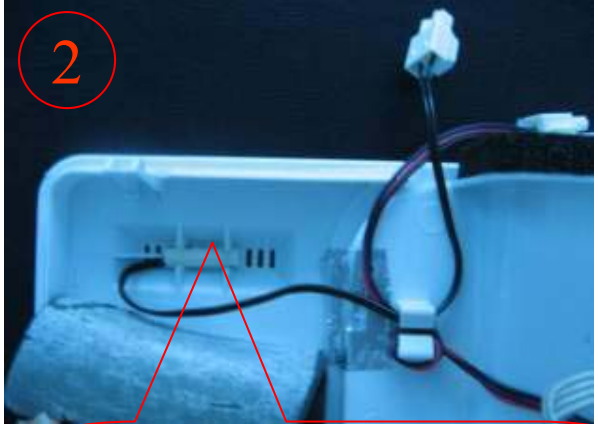
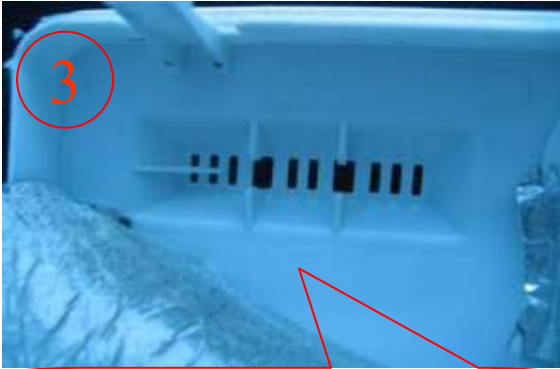
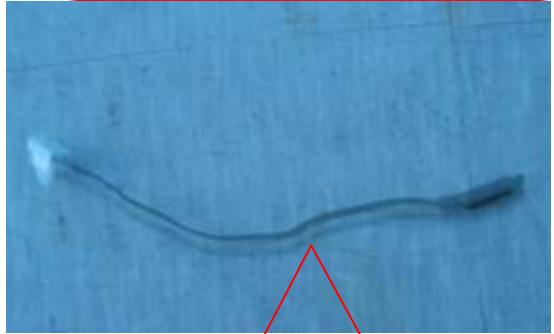







Instruction	
 <p>1.Remove the FRZ airpassage cover;</p>	 <p>2.Remove the rear gasket of FRZ airpassage cover,then you can see the FRZ sensor;</p>
 <p>3.Take off the sensor from the clip;</p>	 <p>4.FRZ sensor wire</p>
<p>Install the FRZ sensor according to the above steps.</p>	

Place clips.

TROUBLESHOOTING

Instruction of replacing sensor

Instruction of replacing sensor

Step	Tools	Operation content	Pic I	Pic II
1.remove fault part	scissors	Open up sensor cover, nip connection thread of which near to sensor root place.		
2.poke insulation skin	knives	Cut off insulation skin orderly till appearing two thread with length of 10mm, new sensor head also cut off 10mm,and make sure connection thread 25mm around.		
3.repair connection port	knives , electric iron	Cut off isolation skin about 2-3mm of 10mm two thread, and with electric iron plating soldering tin(4 connection port).		
4.connection	electric iron ,pyrocondensation pipe	Make pyrocondensation tube cover the two thread, and with electric iron jointing two ports (old sensor port and new sensor port), pay attention to not causing burr.		/
5.seal	electric iron, seal glue	After jointing together, make pyrocondensation located connection jointing point middle part, heat up pyrocondensation pipe in order to make it shrinkage and cover jointing point firmly, and dripping seal glue in order to wet corrupt.		/
6.install	/	Install sensor to sensor cover, then fix it up.	/	/

Instruction of compressor check

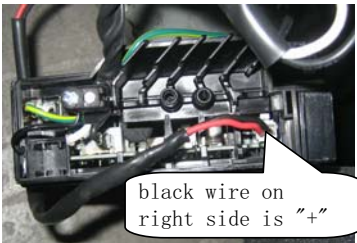
Item	Step	Checkpoint	Tools	
1	Check the power	1、 Measure the voltage of power with a multimeter,if it beyond standard scope,adjust it to normal scope; Notice: measure the power with "AC" of the multimeter. 2、 Check connection of power plug and socket,if it's not good,replace or adjust them.	multimeter,pan-screwdriver,cross-screwdriver	Too high power plug system) c
2	Check the compressor start or not under "test" mode	At the same time,press the two buttons of FRZ temperature adjustment and hold on for 3 seconds,there will be "T1T1" on display panel,which means mandatory start mode.	/	The comp mode. Che so,skip st
3	Check temperature of FRZ compartment	Check the FRZ temperature meet the START temperature or not.	thermometer	If the FRZ temperatu
4	Check the FRZ sensor	Check the resistance of FRZ sensor accord with the actual FRZ temperature or not. Notice: Please check the resistance and the temperature data above.	thermometer,multimeter	If the resis temperatu passes lo
5	Check connector	Check those connectors of main control PCB,display PCB,Inverter PCB,and the compressor terminal.	/	Check the
6	Check connection of "+" and "-".	Make sure that connection of signal input terminal on Inverter PCB is right. Notice: right of signal input terminal is "+",while the left is "-". 	multimeter	If it's wron
7	Test the output of control signal on main control PCB	Measure the voltage of two black wires and the red wire(signal control wire) of Inverter PCB. Notice: The multimeter must be on "DC",generally speaking,the voltage is 2.5V.	multimeter	If there is is bad;if th bad;if the PCB.
8	Check the inverter PCB	If the voltage is normal,the inverter PCB or compressor is bad.Then replace a new inverter PCB and check the compressor start or not.	Inverter PCB	If the com PCB,the c
9	Check the compressor	1、 Adjust the resistance dial of multimeter to zero,measure the resistance of the three terminals of compressor. If the voltage is normal,the compressor doesn't run,but there is sound of "wengweng",the compressor is short-circuit; 2、 If the voltage is normal,the compressor doesn't run,and there isn't sound of "wengweng",the compressor is open-circuit; 3、 Put the measure pen on shell of compressor,if the lamp of measure pen is on,there is electricity leakage.	multimeter,pan-screwdriver,cross-screwdriver	1、 The re 2、 Measu three one the readin 3、 Conne while the resistance compress

7.Other

Icemaker and defrost details

- 1.You can manually start a defrost cycle according to Pressing FRZ< , FRZ> temp adjust keys and RESET(or TEST) for 3 seconds.There will be "T1,T1" on display panel.
- 2.Generally speaking,there will be a deforst cycle after 7 hours working of compressor.If there is less door openings or the temperature is proper,the defrost cycle will increase,maybe 90 hours.
- 3.And the humidity sensor does not matter with the defrost cycle.
- 4.Center mullion heater will be function under certain time proportion if the humidity is heavy or more door openings.
- 5.The Center mullion heater will stop working under proper humidity or less door openings.
- 6.And it's 25W,529Ω.There are the technical datas in connect diagram in service manual.
- 7.The icemaker will stop when drawer is opened even in harvest time.
- 8.You can manually start the icemaker according to pressing FRZ< and REF> temp adjust keys for 3 seconds,the icemaker will cycle one time.
- 9.You can adjust the water lever according to controlling the time of water infusing.Press the 2 time adjust keys for 3 seconds,then the function of water infusing is available.
- 10.When you adjust the water level,you will see "CC".It means milliliter.

Sincere Forever



Haier Group

Tel:86-532-88938356

Web site:<http://www.haier.com>