

SERVICE MANUAL

AIR CONDITIONER

CPF12XHL

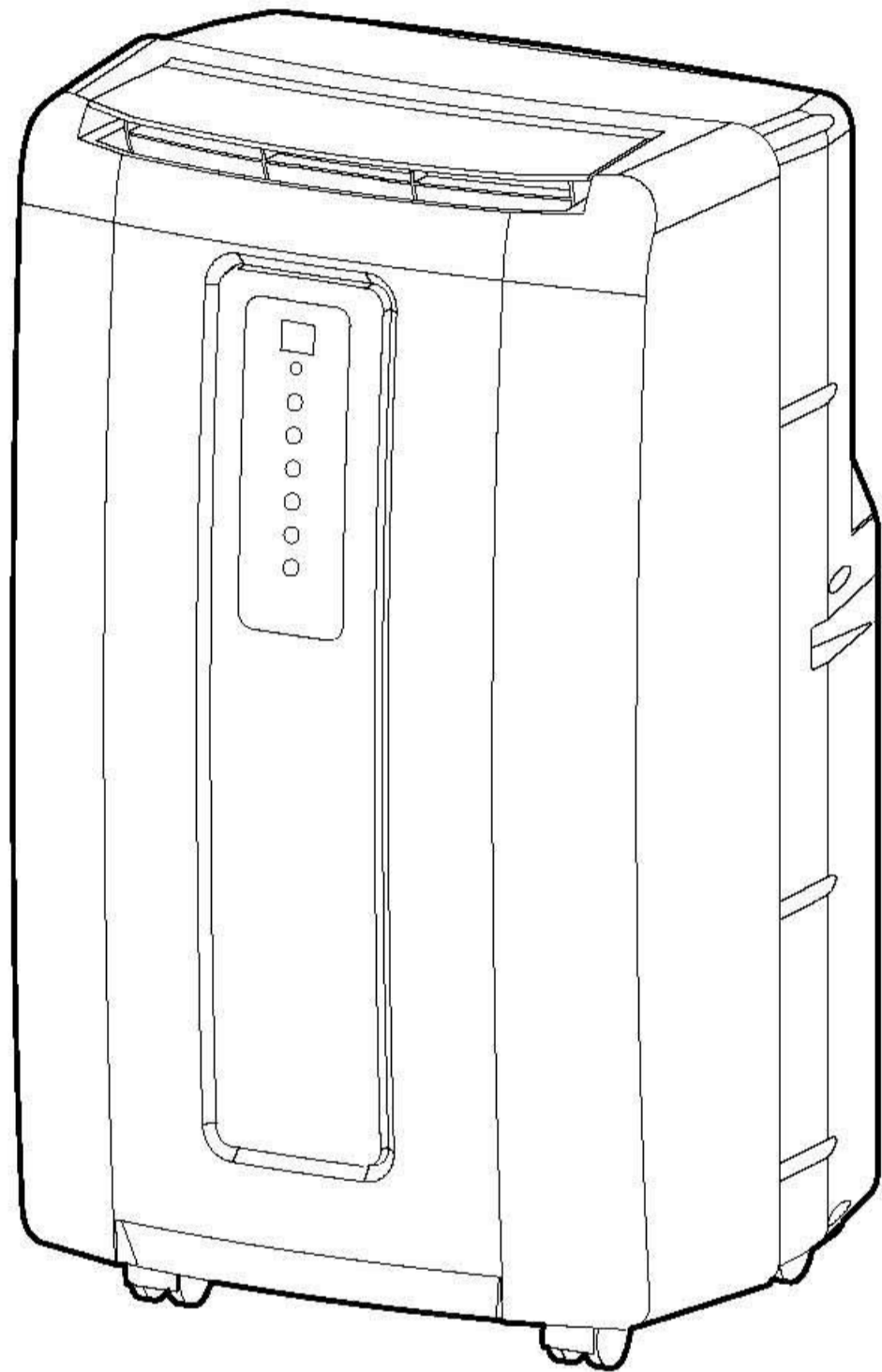

Important points on service, and flow chart for inspecting and repairing the unit	1
Troubleshooting	2
Appearance and unit dimensional	3
Operation	4-5
Technical specifications	6
Refrigerator system and schematic wiring diagrams	7
Exploded view	8
Parts list	9-11

This manual is for the use of technical personnel entrusted with maintenance.

Widetech reserves the right to change this dehumidifier's casing, circuit and parts without notice.

115V 60Hz

IMPORTANT POINTS ON SERVICE OPERATING SAFETY

Please follow these instructions carefully :

- Unplug the unit to avoid any danger from electric shock before disassembling the unit for repair.
- If there is any sound of the refrigerant circulating when in operation, avoid touching the cooling coils.
- If you need to perform any welding or soldering, be sure you are in a well ventilated area.
- Only a qualified professional should perform any welding on the unit.
- When repairing the unit, the specifications listed in this manual must be strictly adhered to when replacing any components.
- When replacing any electrical components they should be factory approved units.
- Be sure that any electrical components are properly wired and in place.

FLOW CHART FOR INSPECTING AND REPAIRING THE UNIT

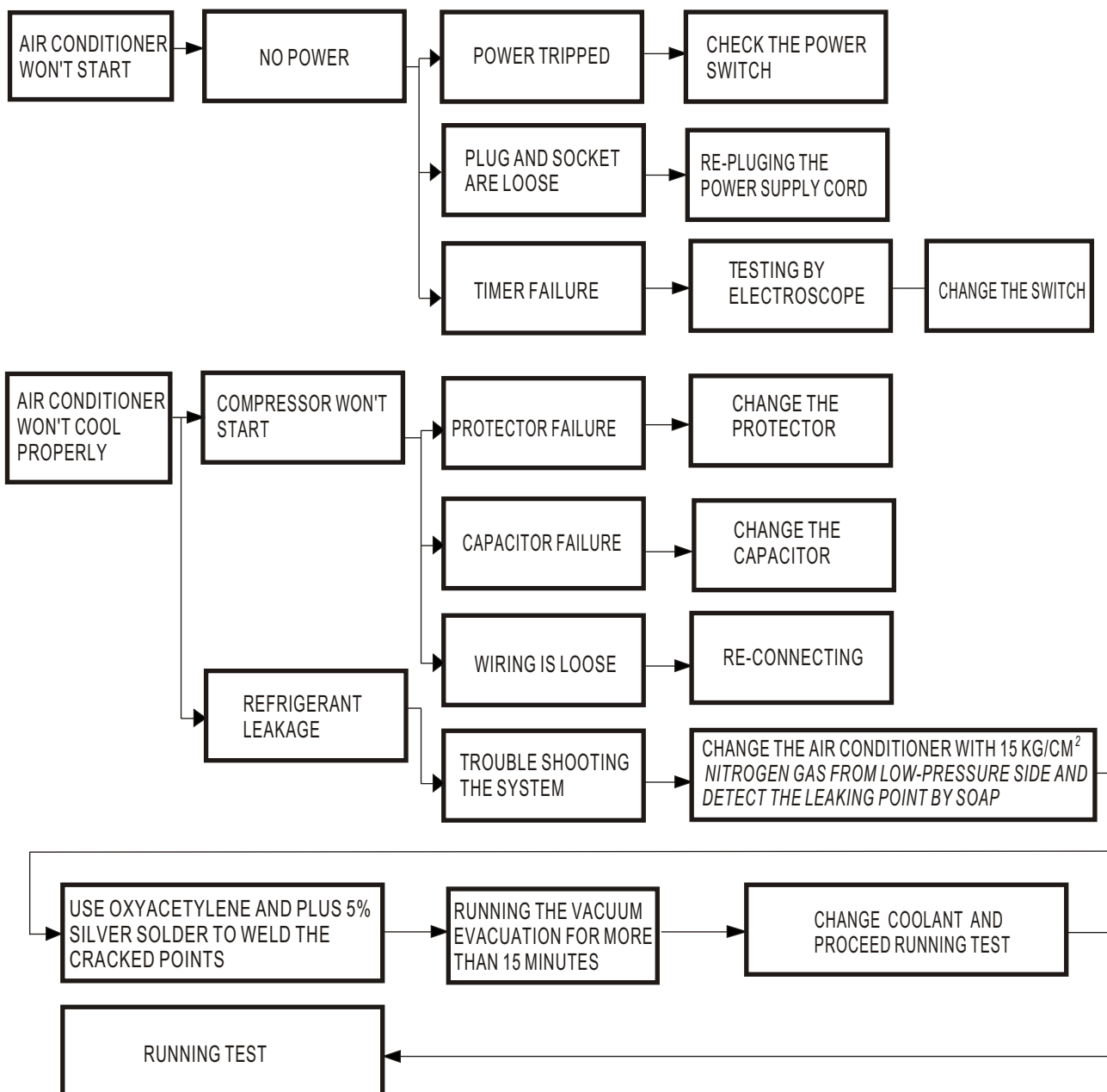

TROUBLESHOOTING

Problem	Analysis
Does not run	<ul style="list-style-type: none">· If the protector trip or fuse is blown.· Please wait for 3 minutes and start again, protector device may be preventing unit to work.· If batteries in the remote controller exhausted.· If the plug is not properly plugged.
Run a short while only	<ul style="list-style-type: none">· If the set temperature is close to room temperature, you can low the set temperature.· Air outlet be blocked by obstacle. Take the obstacle away.
Run but not cool	<ul style="list-style-type: none">· If the door or window open.· If there is other heater appliance work, like heater or lamp, etc..· The air filter is dirty, please clean it.· Air outlet or intake be blocked.· Set temperature is too high.
Do not run and water full indicator lights	<ul style="list-style-type: none">· Drain the water into a prepared container by the drainage pipe on the rear panel of the unit.· If still doesn't work, please consult a qualified technician.

APPEARANCE

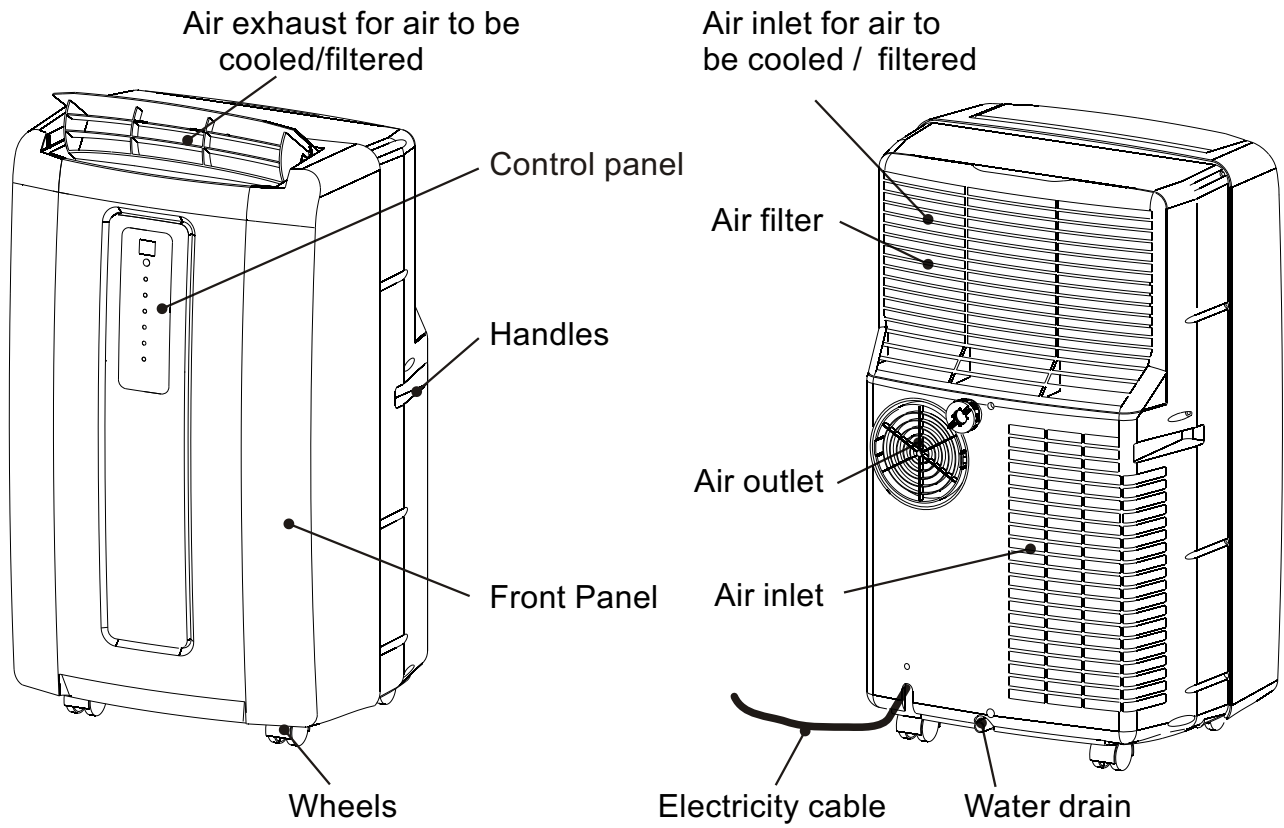

UNIT DIMENSIONAL

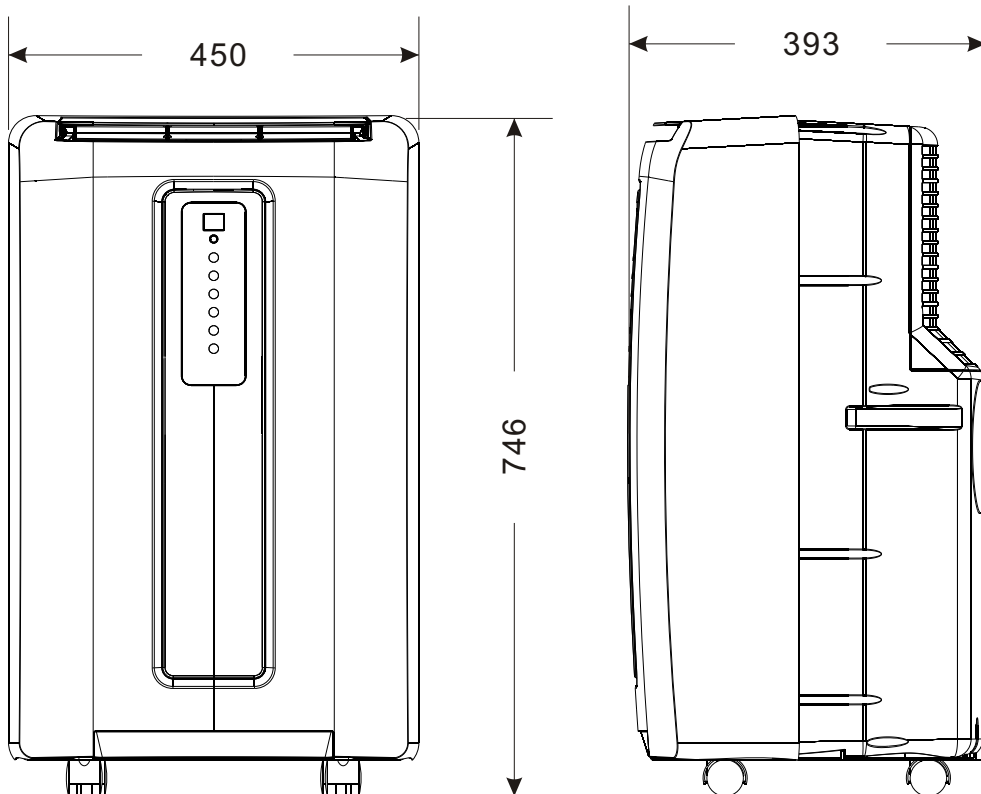

OPERATION

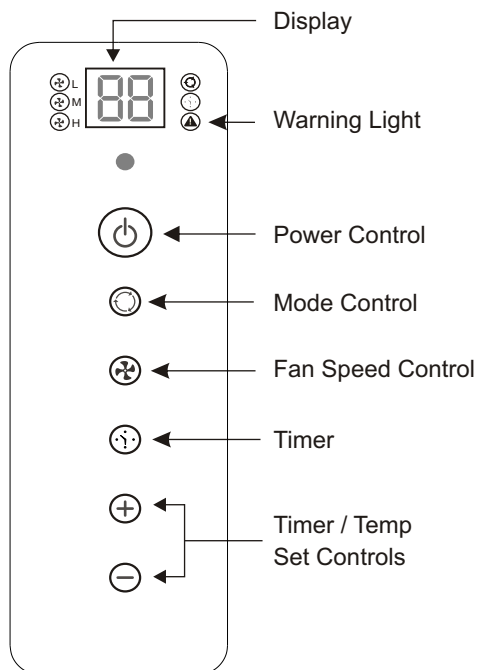

● Dehumidify Mode

When dehumidify mode is selected, the indicator light will shine yellow. Air is dehumidified as it passes through the unit, without being in full cooling mode. The fan will operate in med speed. Fan speed is not adjustable in dehumidify mode.

Note : The air exchange hoses must vent inside the room when using dehumidify mode.

● Fan Mode

When fan mode is selected the indicator light will shine green. Air is circulated throughout the room with no cooling.

Note: unit does not need to be vented in Fan mode

● Heating Mode

When Heating mode is selected the indicator light will shine red.

Heating is activated only when the ambient temperature is below 25 degree C.

Power Control

The power control turns the unit on and off.

Warning Light

Condensed water may accumulate in the unit. If the internal tank becomes full, the Warning Light will shine and the unit will not operate until the unit has been drained.

Mode Control

The Mode Control has three settings:

● Cool ● Dehumidify ● Fan

The settings are adjusted with Mode Control button. A light will indicate which setting is currently being used.

● Cooling Mode

When cool mode is selected, the indicator light will shine blue. During the cooling mode the air is cooled and hot air is exhausted to the outside air through the exhaust tube. Adjust fan speed air through the temperature to suit your desired comfort level.

Note : The air exchange hoses must vent outside the room when using cool mode.

Fan Speed Control

The Fan Speed Control has 3 settings: High, Medium, and Low.

Timer

Auto turn off :

With machine in fan mode, press timer button to select number of hours you would like the unit to run in air conditioning mode until it automatically shuts off.

Auto turn on :

With machine powered off , press timer button to select number of hours until you would like the unit to automatically start running in air conditioning mode.

Timer / Temp set controls

- Used for adjusting the timer and thermostat.
 - The default display is room temperature.
 - In cooling mode, when " " or " " button is pressed, the set temperature is displayed and may be adjusted. After 15 seconds the display will revert back to room temperature. Temperature is only adjustable in cool mode. The time is adjustable between 1~12 hours.
- Note : By pressing both Timer / Temp set buttons at the same time, the display will toggle between Celsius and Fahrenheit.**

OPERATION

Air Conditioner Remote Control

The functions work the same as your air conditioner's touch controls.
All key function can be accessed from the remote control.

CONTROL PANEL

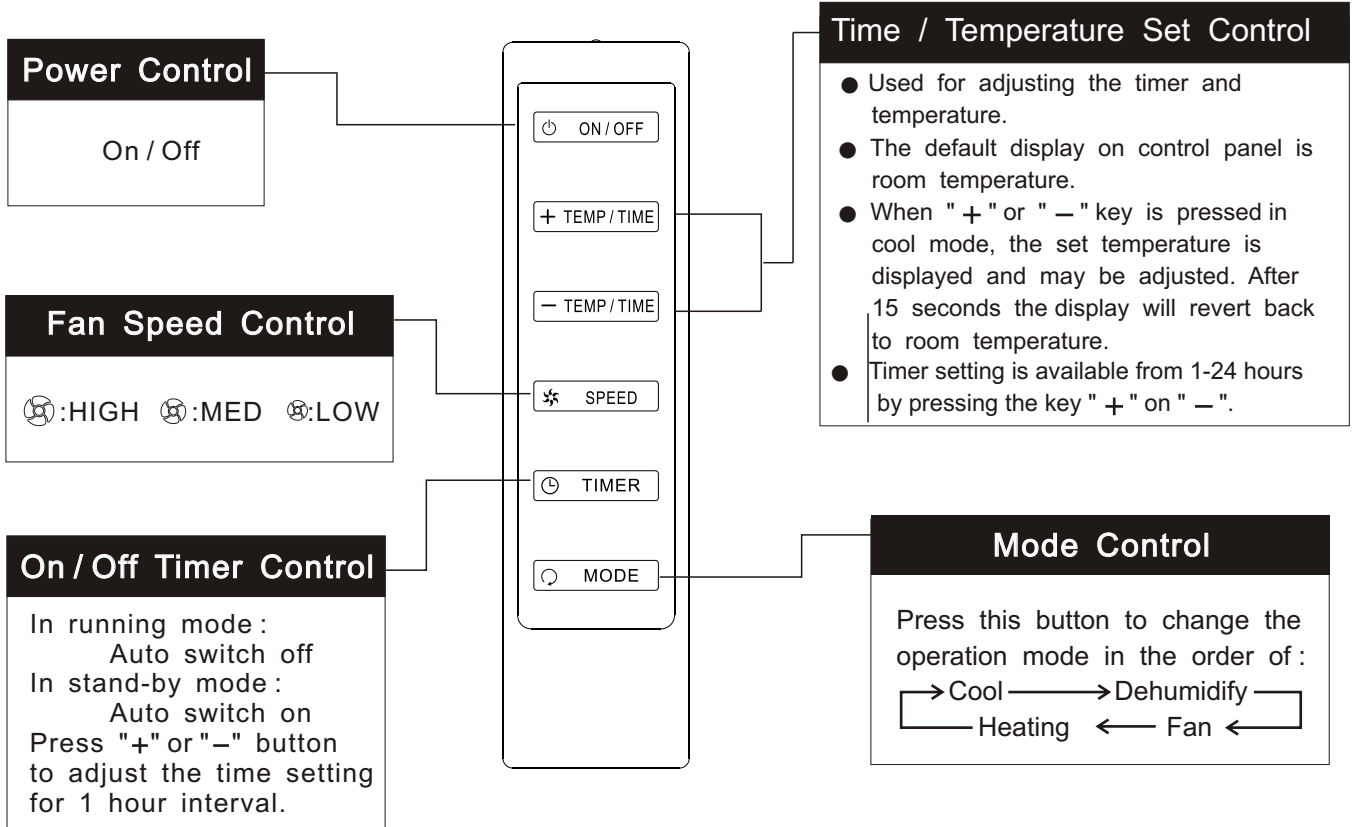

Notes

- Do not drop the remote control.
- Do not place the remote control in a location exposed to direct sunlight.
- The remote control should be placed about 1 meter or more away from TV, or any electrical appliances.

Battery replacement : Remove the cover on the back of the remote control and insert the batteries with the (+) and (-) poles pointing in the proper direction.

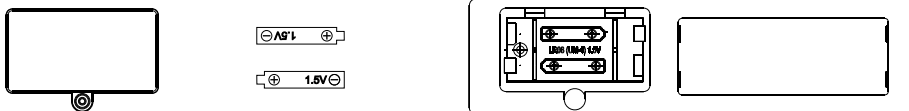

CAUTION

- Use only AAA or IEC R03 1.5V batteries.
- Remove the batteries if the remote control is not used for a month or longer.
- Do not attempt to recharge the supplied batteries.
- All batteries should be replaced at the same time, do not mix old battery .
- Do not dispose of the batteries in a fire as they may explode.

TECHNICAL SPECIFICATIONS

ITEM		UNIT	WAP-357ESH (HAIER CPF12XHL-LP)
OUTER DIMENSION		mm	450W*730H*380D
REFERENTIAL USING AREA		m ²	12~21
RATED VOLTAGE		V/Hz	115 / 60
RUNNING CURRENT		A	10.8 (Cooling)
			10.5 (Heating)
DEHUMIDIFYING CAPACITY		L/H	1.6
COOLING		B.T.U.	12000 (Cooling)
			11000 (Heating)
COMPRESSOR	MODEL		44N100-A2-BCAD
	INPUT POWER	W	1007
	OPERATING CYCLE	uF/V	55/300
	PROTECTOR		B470-135-241C
INDOOR MOTOR	MODEL		LS-16T3-02
	FUSE		2A 134°
	OPERATING CYCLE	uF/V	4/250
OUTDOOR MOTOR	MODEL		LS-53T1-4P
	FUSE		2A 134°
	OPERATING CYCLE	uF/V	9/250
TURBINE FAN MOTOR	MODEL		WT-15T1-03
	FUSE		2A 86°
CAPILLARY		mm	2.6(O.D.)*1.2(I.D.)*800(L)
EVAPORATOR			3R12S15FPI
CONDENSER			(2+1)R16S21FPI
REFRIGERANT		R410A/g	580
WEIGHT		kg	31.5

REFRIGERATOR SYSTEM DIAGRAM

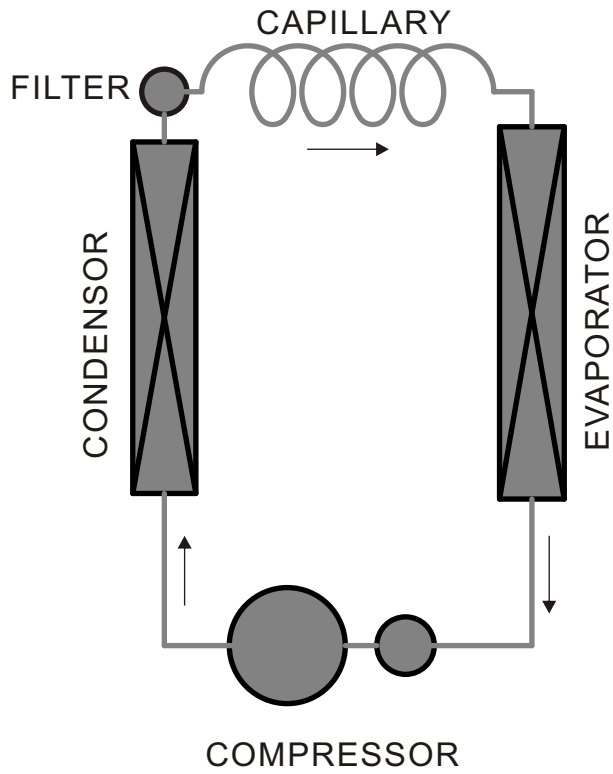

SCHEMATIC WIRING DIAGRAM

