

This Owner's Manual is provided and hosted by [Appliance Factory Parts](#).



# Haier CPRB08XCJ-T Owner's Manual

[Shop genuine replacement parts for Haier  
CPRB08XCJ-T](#)



[Find Your Haier Air Conditioner Parts - Select From 735 Models](#)

----- Manual continues below -----

# SERVIC

## AIR C

**CPRB08XCJ**

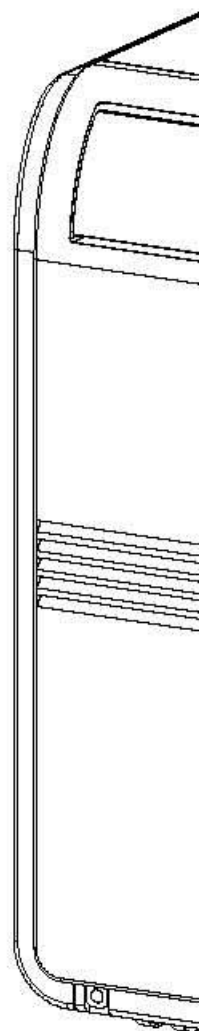

# IMPORTANT POINTS ON SERVICE OPERATING SAFETY

## Please follow these instructions carefully :

- Unplug the unit to avoid any danger from electric shock before disassembling the unit for repair.
- If there is any sound of the refrigerant circulating when in operation, avoid touching the cooling coils.
- If you need to perform any welding or soldering, be sure you are in a well ventilated area.
- Only a qualified professional should perform any welding on the unit.
- When repairing the unit, the specifications listed in this manual must be strictly adhered to when replacing any components.
- When replacing any electrical components they should be factory approved units.
- Be sure that any electrical components are properly wired and in place.

## FLOW CHART FOR INSPECTING AND REPAIRING THE UNIT

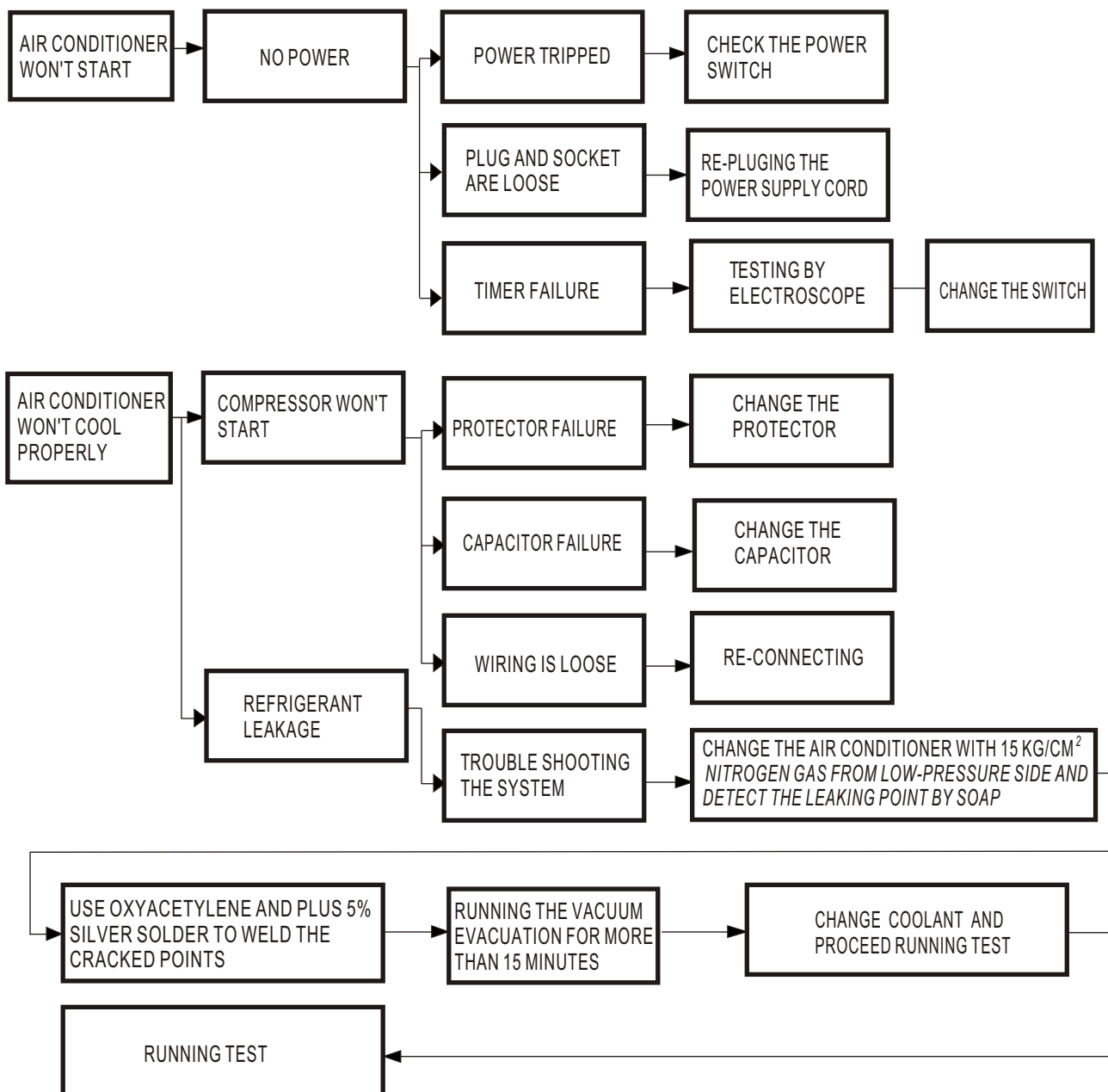

---

## **TROUBLESHOOTING**

---

<b>Problem</b>	<b>Analysis</b>
<b>Does not run</b>	<ul style="list-style-type: none"><li>· If the protector trip or fuse is blown.</li><li>· Please wait for 3 minutes and start again, protector device may be preventing unit to work.</li><li>· If batteries in the remote controller exhausted.</li><li>· If the plug is not properly plugged.</li></ul>
<b>Run a short while only</b>	<ul style="list-style-type: none"><li>· If the set temperature is close to room temperature, you can low the set temperature.</li><li>· Air outlet be blocked by obstacle. Take the obstacle away.</li></ul>
<b>Run but not cool</b>	<ul style="list-style-type: none"><li>· If the door or window open.</li><li>· If there is other heater appliance work, like heater or lamp, etc..</li><li>· The air filter is dirty, please clean it.</li><li>· Air outlet or intake be blocked.</li><li>· Set temperature is too high.</li></ul>
<b>Do not run and water full indicator lights</b>	<ul style="list-style-type: none"><li>· Drain the water into a prepared container by the drainage pipe on the rear panel of the unit.</li></ul> <p>If still doesn't work, please consult a qualified technician.</p>

---

## APPEARANCE

---

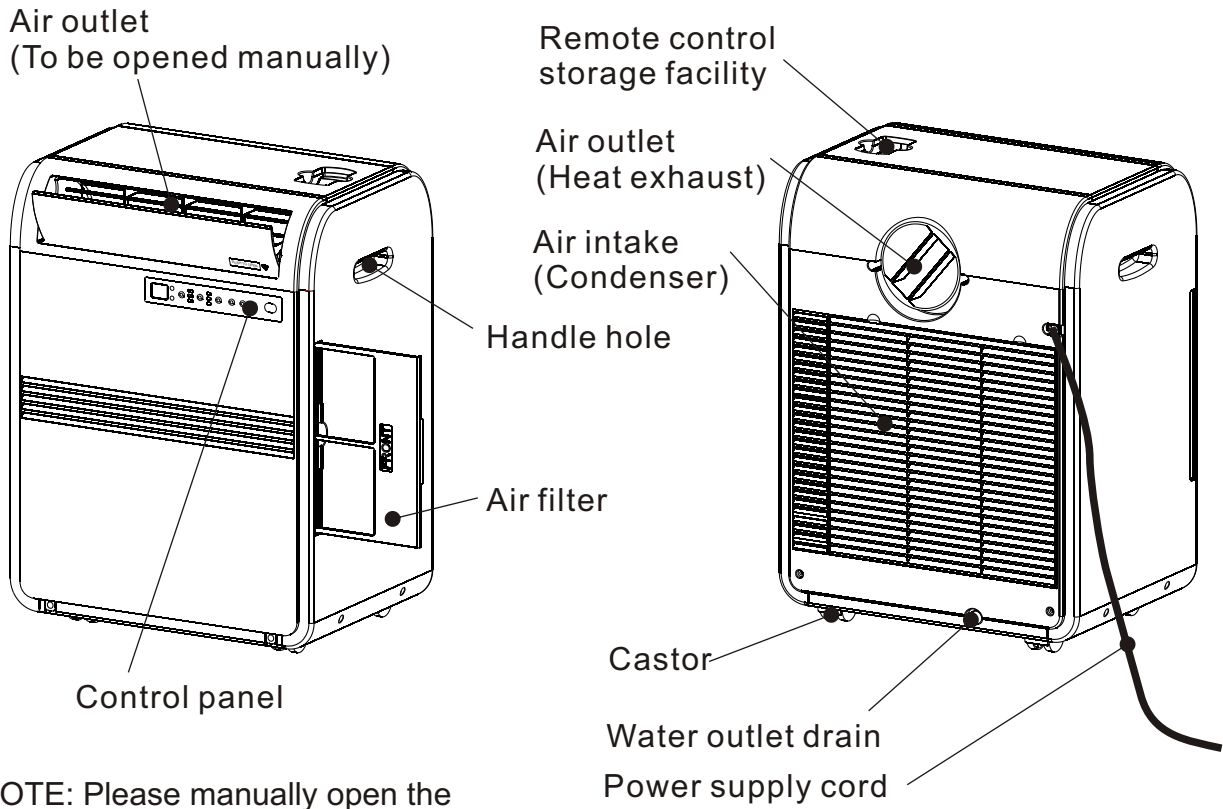

NOTE: Please manually open the air outlet to desired position.

---

## UNIT DIMENSIONAL

---

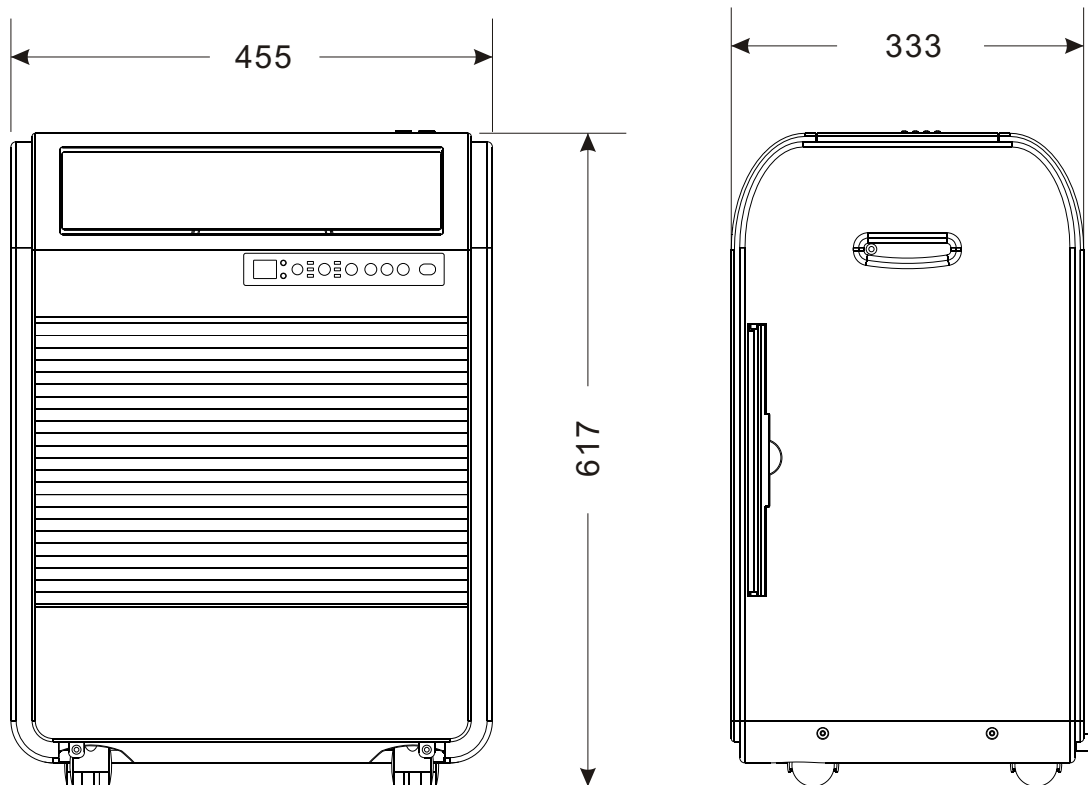

# OPERATION

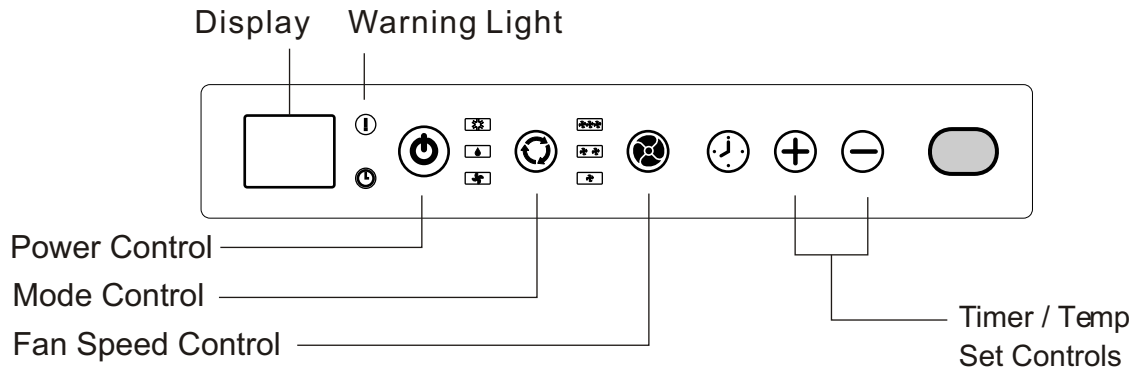

## Power Control

The power control turns the unit on and off.

## Warning Light **▲**

Condensed water may accumulate in the unit. If the internal tank becomes full, the warning light will light up and the unit will not operate until the unit has been drained.

## Mode Control

The Mode Control has three settings:

### ● Cool ● Dehumidify ● Fan

The settings are adjusted with Mode Control button. A light will indicate which setting is currently being used.

#### ● Cooling Mode

When cool mode is selected, the indicator light turns blue. During the cooling mode the air is cooled and hot air is exhausted to the outside through the exhaust tube. Adjust fan speed and air temperature to suit your desired comfort level.

**Note : The air exchange hoses must vent outside the room when using cool mode.**

#### ● Dehumidify Mode

When dehumidify mode is selected, the indicator light turns yellow. Air is dehumidified as it passes through the unit, without being in full cooling mode. If room temperature is higher than 25 degree Celsius, fan speed can be adjusted; otherwise fan speed is fixed to "Low".

**Note : If the unit is to be used as a dehumidifier, do not connect the exhaust hose let the warm air return to the room.**

**Continuous drainage is then necessary.**

#### ● Fan Mode

When fan mode is selected the indicator light will shine green. Air is circulated throughout the room with no cooling.

**Note: unit does not need to be vented in Fan mode**

## Fan Speed Control

The Fan Speed Control has 3 settings: High, Medium, and Low.

## Timer

### Auto turn off :

With machine in running mode, press timer button to select number of hours you would like the unit to run in air conditioning mode until it automatically shuts off.

### Auto turn on :

With machine stand by mode, press timer button to select number of hours until you would like the unit to automatically start running in air conditioning mode.

## Timer / Temp set controls

- Used for adjusting the timer and thermostat.
- The default display is room temperature.
- In cooling mode, when "+" or "-" button is pressed, the set temperature is displayed and may be adjusted. After 15 seconds the display will revert back to room temperature. Temperature is only adjustable in cool mode. The time is adjustable between 1~12 hours. Note : By pressing both Timer / Temp set buttons at the same time, the display will toggle between Celsius and Fahrenheit.

# OPERATION

## CONTROL PANEL

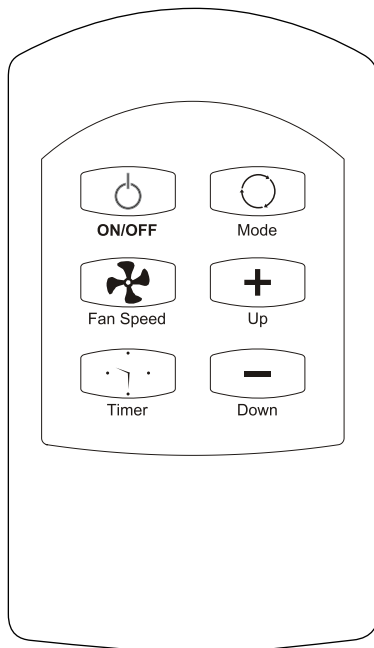

### Power Control

The power control turns the unit on and off.

### Mode Control

The Mode Control has 3 settings:

- Cool ● Dehumidify ● Fan

The settings are adjusted by Mode Control button.

#### ● Cooling Mode

During the cooling mode the air is cooled and hot air is exhausted to the outside through the exhaust tube. Adjust fan speed and air temperature to suit your desired comfort level.

**Note : The air exchange hoses must vent outside the room when using Cool Mode.**

#### ● Dehumidify Mode

Air is dehumidified as it passes through air conditioner, without being in full cooling mode. If room temperature is higher than 25°C, fan speed can be adjusted; otherwise fan speed is fixed to " low ".

**Note : If the unit will be used mainly as dehumidifier, do not connect the exhaust hose and let the warm air return in the room. Continuous drainage is then necessary and more efficient**

#### ● Fan Mode

Air is circulated throughout the room with no cooling.

**Note: unit does not need to be vented in Fan Mode.**

### Fan Speed Control

The Fan Speed Control has 3 settings: Auto, High, Medium, and Low.

### Temp Set Controls

Press " Up " or " Down " to set temperature, The setting range is from 61°F to 89°F.

**Note: When using DEHUMIDIFY or FAN MODE, temperature setting button invalid.**

### Timer Setting Control

- When you use the timer setting button while the unit is operation, you can preset a timer for the unit to turn off.
- When you use the timer setting button while the unit is on standby, you can preset a timer for the unit to turn on.
- If you press the "ON/OFF" button, the preset timer function will be cancelled.
- Timer setting range is 1~24 hours.

## TECHNICAL SPECIFICATIONS

ITEM		UNIT	WAP-023EA
OUTER DIMENSION		mm	455W*617H*333D
REFERENTIAL USING AREA		m <sup>2</sup>	9~18
RATED VOLTAGE		V/Hz	115 / 60
COOLING CAPACITY		B.T.U.	8000
DEHUMIDIFYING CAPACITY		L/H	1.6
RUNNING CURRENT		A	7.9
POWER CONSUMPTION		W	840
INDOOR AIR VOLUME		M <sup>3</sup> /hr	280
COMPRESSOR	MODEL		41T068-A2-ANII
	INPUT POWER	W	771
	OPERATING CYCLE	uF/V	35/300
	PROTECTOR		MRA12320-12082
MOTOR	MODEL		LS-65T3-4P
	OUTPUT POWER	W	65
	OPERATING CYCLE	uF/V	12/250
TURBINE FAN MOTOR	MODEL		WT-15T1-04
	OUTPUT POWER	W	15
CAPILLARY		mm	2.6(O.D.)*1.2(I.D.)*600(L)
EVAPORATOR			2R12S21FPI
CONDENSER			(1R14S+1R16S)21FPI
REFRIGERANT		R410A/g	470
WEIGHT		kg	25.5

