

This Owner's Manual is provided and hosted by [Appliance Factory Parts](#).



MASTERBUILT 20070111 Owner's Manual

[Shop genuine replacement parts for MASTERBUILT
20070111](#)



[Find Your MASTERBUILT Grill Parts - Select From 590 Models](#)

----- Manual continues below part list -----

Available Replacement Parts for MASTERBUILT 20070111

02342	control knob; universal
9007090065	Wood Chip Bowl w/ Lid
9007090067	Water Bowl
9005100025	Grease Clip
9005100039	Drip Cup
9904100056	Temperature Gauge
9907100018	Control Panel Kit
9005100034	Cooking Grate
9905100014	Leg Kit
9905100015	Door Handle Kit
9907100022	Grate Support Kit
9007100030	Wood Chip Grate
9907100019	Element Support Kit



Masterbuilt Manufacturing, Inc
 1 Masterbuilt Court
 Columbus, Georgia 31907
 Customer Service 1-800-489-1581





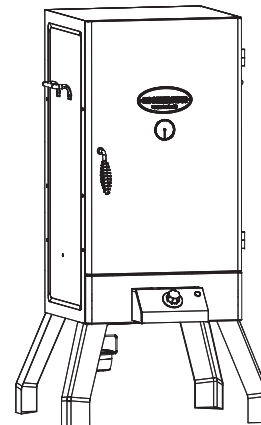

**ASSEMBLY, CARE & USE MANUAL
 WARNING & SAFETY INFORMATION
 ELECTRIC SMOKER MODELS 20070111, 20071712
 THIS PRODUCT IS FOR OUTDOOR USE ONLY ~ HOUSEHOLD TYPE**



Manual Code: 9807100041 082311-04JH

Tools required for assembly: Adjustable Wrench, Phillips Head Screwdriver.

 CARBON MONOXIDE HAZARD 	 WARNING 
<p>Burning wood gives off carbon monoxide which can cause death.</p> <p>DO NOT burn wood chips inside homes, vehicles, tents, garages or any enclosed areas.</p> <p>Use only outdoors where it is well ventilated.</p>	<p>This manual contains important information necessary for the proper and safe use of this unit.</p> <p>Read and follow all warnings and instructions before using smoker and during use.</p> <p>Keep this manual for future reference. Some parts may have sharp edges. Handle with care.</p>
<p>Failure to follow these warnings and instructions properly could result in personal injury or death.</p>	

WARNINGS & IMPORTANT SAFEGUARDS

READ ALL INSTRUCTIONS

When using electrical appliances, basic safety precautions should always be followed including the following:

- For outdoor use only. Do not operate in an enclosed area.
- Unit **MUST** be on the ground. Do not place unit on tables or counters.
- Do not plug in electric smoker until fully assembled and ready for use.
- Use only on properly grounded outlet.
- Do not use during an electrical storm.
- Do not expose electric smoker to rain or water at anytime.
- To protect against electrical shock do not immerse cord, plugs, controls, portable appliances (or other specified part or parts) in water or other liquid.
- Do not operate any appliance with a damaged cord or plug, or after appliance malfunctions or is dropped or damaged in any manner. Contact Masterbuilt Customer Service for assistance at 1-800-489-1581.
- Keep a fire extinguisher accessible at all times while operating electric smoker.
- Do not let cord touch hot surfaces.
- Do not place on or near a hot gas or electric burner, or in a heated oven.
- Store products indoors when not in use - out of reach of children.
- Keep children and pets away from electric smoker at all times. Do not allow children to use electric smoker. Close supervision is necessary should children or pets be in area where electric smoker is being used.
- Fuel, such as charcoal briquettes or heat pellets, are not to be used in electric smoker.
- Never use electric smoker as a heater (READ CARBON MONOXIDE HAZARD).
- Use electric smoker only on a level, stable surface to prevent tipping.
- Electric smoker is HOT while in use and after.
- Electric smoker is HOT while in use and will remain HOT for a period of time afterwards. Use caution.
- Do not touch HOT surfaces. Use handles or knobs. Be sure handles are assembled and fastened properly.
- Do not allow anyone to conduct activities around electric smoker during or following its use until the unit has cooled. Electric smoker is HOT during operation and remains HOT for a period of time following use.
- The use of alcohol, prescription or non-prescription drugs may impair the user's ability to properly assemble or safely operate electric smoker.
- Avoid bumping or impacting electric smoker.

WARNINGS & IMPORTANT SAFEGUARDS CONTINUED ON PAGE 2

LIMITED WARRANTY INFORMATION

Masterbuilt warrants its products to be free from defects in material and workmanship under proper assembly, normal use and recommended care for 90 days from the date of original retail purchase.

Masterbuilt warranty does not cover paint finish as it may burn off during normal use.

Masterbuilt warranty does not cover rust of the unit.

Masterbuilt requires reasonable proof of purchase for warranty claims and suggests that you keep your receipt. Upon the expiration of such warranty, all such liability shall terminate.

Within the stated warranty period, Masterbuilt, at its discretion, shall repair or replace defective components free of charge with owner being responsible for shipping. Should Masterbuilt require return of component(s) in question for inspection Masterbuilt will be responsible for shipping charges to return requested item.

This warranty excludes property damage sustained due to misuse, abuse, accident, damage arising out of transportation, or damage incurred by commercial use of this product.

This expressed warranty is the sole warranty given by Masterbuilt and is in lieu of all other warranties, expressed or implied including implied warranty, merchantability, or fitness for a particular purpose.

Neither Masterbuilt nor the retail establishment selling this product, has authority to make any warranties or to promise remedies in addition to or inconsistent with those stated above.

Masterbuilt's maximum liability, in any event, shall not exceed the purchase price of the product paid by the original consumer/ purchaser. Some states do not allow the exclusion or limitation of incidental or consequential damages. In such a case, the above limitations or exclusions may not be applicable.

California residents only: Notwithstanding this limitation of warranty, the following specific restrictions apply; if service, repair, or replacement of the product is not commercially practical, the retailer selling the product or Masterbuilt will refund the purchase price paid for the product, less the amount directly attributable to use by the original buyer prior to the discovery of the nonconformity. Owner may take the product to the retail establishment selling this product in order to obtain performance under warranty.

This expressed warranty gives you specific legal rights, and you may also have other rights which vary from state to state.

Go Online www.masterbuilt.com
or complete and return to
Attn: Warranty Registration
Masterbuilt Mfg. Inc.
1 Masterbuilt Court - Columbus, GA 31907

Name: _____

Address: _____

City, State/Province, Postal Code: _____

Phone Number: _____ E-Mail Address: _____

Model Number: _____ Serial Number: _____

Purchase Date: _____ Place of Purchase: _____

*Model Number and Serial Number are located on silver label on back of unit.

MASTERBUILT SMOKIN' RECIPES

SMOKED STUFFED SALMON

Servings for 4



INGREDIENTS:	
Salmon (drawn)	4 - 5 lbs (1.8-2.2 kgs)
Oil	3 lbs
Green Onion (chopped)	1/2 cup
Tomato (peeled and chopped)	1 cup
Dill (fresh and chopped)	1/2 cup
Bread Cubes (dry)	1/2 cup
Celery (chopped)	1/2 cup
Salt	1/2 tsp
Lemon Pepper	1/2 tsp
Garlic (minced)	1 clove

SUGGESTED WOOD FOR SMOKING:
Hickory Chips

INSTRUCTIONS:
Prepare salmon and brush with oil. Combine remaining ingredients in a small bowl. Stuff salmon with mixture. Place salmon on a sheet of heavy aluminum foil that has been doubled and greased. Place in smoker at 225°F (107°C) and cook for 3 to 4 hours. Make sure there is room on either side of foil to allow airflow inside smoker.

MAPLE GLAZED HAM

Servings for 6-8

INGREDIENTS:		
Ham Shank or Butt (fully cooked, bone-in)	5 - 7 lbs (2.2-3.1 kgs)	
Maple Syrup	1 1/2 cup	
Ginger	1 tsp	
Nutmeg	1/2 tsp	
Allspice	1/2 tsp	
Cloves	1/2 whole	
Pineapple Slices (canned)	1 can	
Maraschino Cherries	1 jar	

SUGGESTED WOOD FOR SMOKING:
Hickory or Mesquite Chips



INSTRUCTIONS:
Remove thick skin and trim fat leaving no more than 1/2" (3mm) thick covering on ham. Score ham. Combine syrup, ginger, nutmeg, and allspice in a small bowl. Place ham in a large dish and baste with syrup mixture. Let ham stand in syrup mixture for 1 to 2 hours basting frequently until ham at room temperature. When ready to smoke remove ham from dish and stud with cloves. Place ham in 225°F (107°C) smoker. Cook for 2 to 3 hours. Baste with syrup mixture at least two times during cooking time. Before last hour of smoking, decorate ham with canned pineapple and cherries and baste. Internal temperature of ham should be at 130°F to 140°F (54-60°C) when heated thru.

SMOKED TROUT

Servings for 6



INGREDIENTS:	
Trout Fillets	4 - 6
Water	2 cups
Soy Sauce	1/2 cup
Teriyaki Sauce	1/2 cup
Salt	1/2 cup
Lemon Pepper	1 tsp
Garlic Salt	
Dill Seed	

SUGGESTED WOOD FOR SMOKING:
Hickory, Alder or Apple Chips

INSTRUCTIONS:
Mix recommended amounts of water, soy sauce, teriyaki sauce and salt with other ingredients to your liking in a small container. Place fillets into marinade, cover and let soak in refrigerator overnight. Smoke for 3 to 4 hours or until meat is flaky and dry in smoker at 225°F (107°C).

SMOKED PORK BUTT

Servings for 6



INGREDIENTS:	
Fresh Pork Butt	7 lbs (3.1 kgs)
Salt	1/2 tsp
Brown Sugar	1/2 cup
Chili Powder	2 lbs

SUGGESTED WOOD FOR SMOKING:
Apple Chips

INSTRUCTIONS:
Mix ingredients and rub onto pork butt. Cook pork butt for 5 hours in 225°F (107°C) smoker using apple wood chips during first 3 hours. After 5 hours remove butt and wrap in heavy foil. Cook for an additional 1 to 1 1/2 hours. Internal temperature should be 160°F (71°C). Serve.

SMOKED TURKEY

Servings for 6-8



INGREDIENTS:	
Turkey	10 - 14 lbs (4.5-6.3 kgs)
Salt	1 lbs
Sugar	2 lb
Cinnamon	1/2 lbs
Apple (cored, peeled, and quartered)	1 average
Onion (quartered)	2 medium
Celery stalks with leaves	4 stalks

SUGGESTED WOOD FOR SMOKING:
Hickory or Apple Chips

INSTRUCTIONS:
Thaw turkey according to package directions if necessary. Remove giblets and neck. Rinse and pat dry. Sprinkle turkey cavity with salt. Combine sugar and cinnamon in small bowl. Dredge apple in mixture. Stuff apple, onion and celery into cavity. Close with skewers. Tie ends of legs to tail with kitchen string. Lift wing tips up and over the back to tuck under. Set smoker to 225°F (107°C). Place turkey on cooking rack and cook for 8 to 12 hours or until inner thigh temperature reaches 160°F (65°C). Cover turkey and chili or let stand 20 minutes before carving. Serve.



WARNINGS & IMPORTANT SAFEGUARDS continued



- Never move electric smoker when in use. Allow electric smoker to cool completely before moving or storing.
- Be careful when removing food from electric smoker. All surfaces are HOT and may cause burns. Use protective gloves or long, sturdy cooking tools.
- Do not cover cooking racks with metal foil. This will trap heat and cause severe damage to electric smoker.
- Drip tray is only for the bottom of electric smoker. Do not put drip tray on cooking racks this may damage electric smoker.
- Use Extreme caution when removing tray or disposing of hot grease.
- Wood chip bowl is HOT when electric smoker is in use. Use caution when adding wood.
- To disconnect, turn controller "OFF" then remove plug from outlet.
- Remove plug from outlet when the appliance is not in use, before putting on or taking off parts, and before cleaning. Allow to cool before handling.
- Dispose of cold ashes by placing them in aluminum foil, soaking with water and discarding in a non-combustible container.
- Do not store electric smoker with HOT ashes inside unit. Store only when all surfaces are cold.
- Accessory attachments not supplied by Masterbuilt Manufacturing, Inc. are not recommended and may cause injury.
- Never use electric smoker for anything other than its intended purpose. This unit is not for commercial use.
- Always use electric smoker in accordance with all applicable local, state and federal fire codes.
- Longer extension cords are available and may be used if care is exercised in their use.
- If a longer extension cord is used the marked rating should be at least as great as the electrical rating of the appliance.
- The extension cord must be a grounding -type 3-wire cord.
- Outdoor extension cords must be used with outdoor use products and are marked with suffix "W" and with the statement "Suitable for Use with Outdoor Appliances."
- CAUTION - To reduce the risk of electric shock, keep extension cord connection dry and off the ground.
- Extreme caution must be used when moving an appliance containing hot liquids.
- Do not clean this product with a water sprayer or the like.
- Do not clean with metal scouring pads. Pieces can break off the pad and touch electrical parts, creating a risk of electrical shock.

SAVE THESE INSTRUCTIONS.



WARNING



Combustion by-product produced when using this product contains chemicals known to the State of California to cause birth defects, other reproductive harm, or cancer.

The materials used in this product may contain lead a chemical known to the State of California to cause birth defects and other reproductive harm.



DO NOT RETURN TO RETAILER
 For Assembly Assistance, Missing or Damaged Parts
 Call: MASTERBUILT Customer Service at 1-800-489-1581 or
 EMAIL us at: customerservice@masterbuilt.com.

PARTS LIST

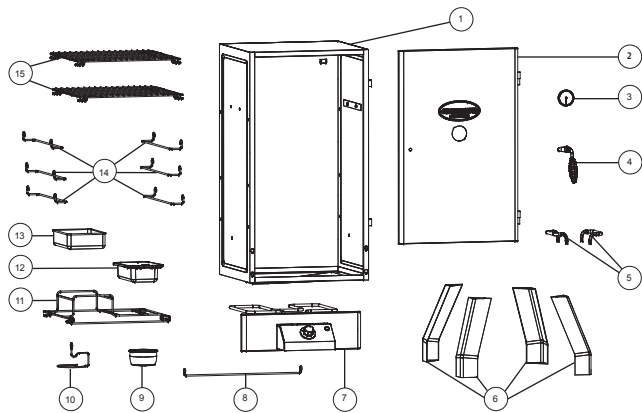

PART NO.	QUANTITY	DESCRIPTION	PART NO.	QUANTITY	DESCRIPTION
1	1	Smoker Body	9	1	Drip Cup
2	1	Door	10	1	Grease Clip
3	1	Temperature Gauge	11	1	Wood Chip Grate
4	1	Door Handle	12	1	Wood Chip Tray w/ Lid
5	2	Side Handle	13	1	Water Bowl
6	4	Leg	14	6	Grate Support (Pre-Assembled)
7	1	Control Panel/w Element	15	2	Cooking Grate
8	1	Element Support			

TROUBLESHOOTING GUIDE

Symptom	Cause	Possible Solution
Power light won't come on	Not plugged into wall	Check wall connection
	House fuse tripped	Make sure other appliances are not operating on the same electrical circuit. Check household fuses.
	Controller malfunctioning	Contact Masterbuilt at 1.800.489.1581
Unit takes excessive amount of time to heat up	Unit plugged into an extension cord	Set unit so an extension cord does not have to be used
	Door not closed properly	Close door and fasten latch securely
	Controller malfunctioning	Contact Masterbuilt at 1.800.489.1581
Grease is leaking out of smoker	Drip cup not in place	Reposition so drip cup aligns to drain hole in bottom of unit
	Excess grease or oil build-up in unit	Clean unit
No smoke	Add wood chips See Page 8	Contact Masterbuilt at 1.800.489.1581
Temperature rapidly decreased, or shut down after few hours of use	Faulty control unit	Contact Masterbuilt at 1.800.489.1581
Power light is on, unit isn't heating	Controller/unit malfunctioning	Contact Masterbuilt at 1.800.489.1581
Controller does not adjust heat	Controller/unit malfunctioning	Contact Masterbuilt at 1.800.489.1581

WOOD SMOKING GUIDE FOR MEATS

WOOD FLAVOR	POULTRY	FISH	HAM	BEEF	PORK	LAMB
Hickory Pungent, smoky, bacon-like flavor	✓	✓	✓	✓	✓	
Mesquite Sweet and delicate flavor	✓			✓		✓
Alder Delicate, wood smoke flavor	✓	✓			✓	
Pecan Bold and heavy flavor	✓	✓			✓	
Maple Sweet, subtle flavor	✓				✓	
Apple Sweet, delicate flavor	✓	✓			✓	
Cherry Sweet, delicate flavor	✓				✓	

TO ENSURE THAT IT IS SAFE TO EAT, FOOD MUST BE COOKED TO THE MINIMUM INTERNAL TEMPERATURES LISTED IN THE TABLE BELOW.

USDA* Safe Minimum Internal Temperatures	
Fish	145°F (63°C)
Pork	160°F (71°C)
Egg Dishes	160°F (71°C)
Steaks and Roasts of Beef, Veal or Lamb	145°F (63°C)
Ground Beef, Veal or Lamb	160°F (71°C)
Whole Poultry (Turkey, Chicken, Duck, etc.)	165°F (74°C)
Ground or Pieces Poultry (Chicken Breast, etc.)	165°F (74°C)

* United States Department of Agriculture

HARDWARE LIST

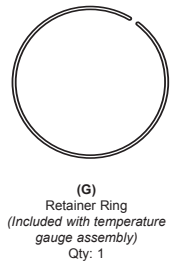
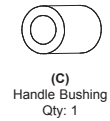
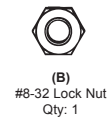
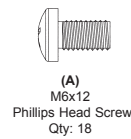

REPLACEMENT PARTS LIST

DESCRIPTION	ITEM NO.	DESCRIPTION	ITEM NO.
Body Kit	9907100016	Wood Chip Bowl	9007090065
Door Handle Kit	9905100015	Wood Chip Bowl Holder	9007100030
Leg Kit	9905100014	Water Bowl	9007090067
Body Handle Kit	9907100017	Drip Cup	9005100039
Control Panel Kit	9907100018	Grease Clip	9005100025
Element Support Kit	9907100019	Control Knob	9007100031
Grate Support Kit	9907100022	Hardware Kit	9907100020
Door with Logo Plate	9907100029	English Instruction Manual	9907100041
Cooking Grate	9005100034	Temperature Gauge	9904100056

ASSEMBLY INSTRUCTIONS

Tools required for assembly: Adjustable Wrench, Phillips Head Screwdriver.

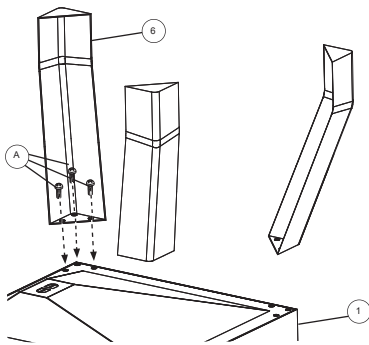

Step 1 Carefully position smoker as shown.

Attach leg (6) to bottom of smoker body (1) using phillips head screws (A).

Repeat step for remaining legs.

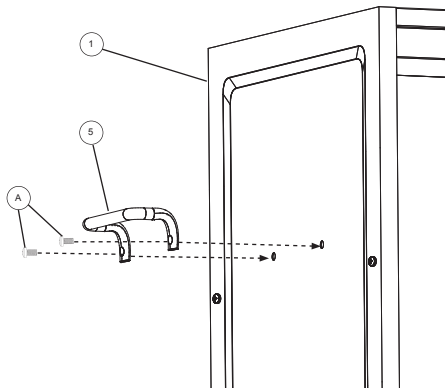

Step 2 Mount side handle (5) to smoker body (1) using phillips screws (A).

Repeat step for opposite side.

5

OPERATION INSTRUCTIONS

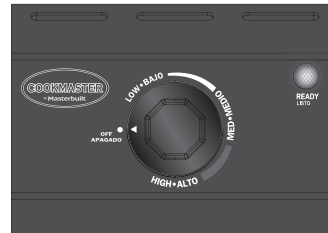

Step 1: Plug power cord into an outlet (refer to "Warnings & Important Safeguards" section of manual).

Step 2: Turn dial to set temperature. Ready light will turn off when unit has reached set temperature and is ready for use.

Step 3: When cooking time has elapsed and food is done, turn dial to MIN and unplug power cord from outlet.

* Allow excess grease to drain into grease clip shown on page 8.

IMPORTANT FACTS ABOUT USING SMOKER

- Maximum temperature will range between 266°F - 284°F (130°C - 140°C) when control panel is set on HI.
- Wood chip bowl MUST be in place when using smoker. This minimizes the chance of wood flare ups.
- Wood chips must be used in order to produce smoke and create the smoke flavor. See "Wood Smoking Guide for Meats" section in this manual.
- Check drip can often during cooking. Empty drip can before it gets full. Drip cup may need to be emptied periodically during cooking.
- Do not open smoker door unless necessary. Opening smoker door causes heat to escape and may cause wood to flare up. Closing the door will re-stabilize the temperature and stop flare up.
- Do not leave old wood ashes in the wood tray. Once ashes are cold empty tray. Tray should be cleaned out prior to and after each use to prevent ash buildup.
- This is a smoker. There will be a lot of smoke produced when using wood chips. Smoke will escape through seams and turn the inside of smoker black. **This is normal.**

HOW TO CLEAN SMOKER

For cooking grates, water bowl and drip cup use a mild dish detergent. Rinse and dry thoroughly.

For wood chip bowl, clean frequently to remove ash build up, residue and dust.

For the interior and exterior of smoker simply wipe down with a damp cloth. Do not use a cleaning agent. Make sure to dry thoroughly.

Do not clean with metal scouring pads. Pieces can break of the pad and touch electrical parts, creating a risk of electrical shock.

ALWAYS MAKE SURE UNIT IS UNPLUGGED AND COOL TO THE TOUCH BEFORE CLEANING AND STORING.

10

SMOKER IS NOW READY FOR USE

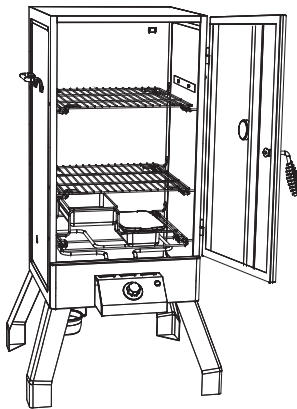

PRESEASON INSTRUCTIONS

Preseason smoker prior to first use. Make sure water bowl is in place with NO WATER. Set control panel to MED and run unit for 3 hours. Shut down and allow to cool. Some smoke may appear during this time, this is normal.
During last 45 minutes, add 1 cup of wood chips in wood chip bowl to complete preseasoning.

TIPS FOR USING WOOD CHIPS

- Never use more than 1 cup of wood chips at a time. Never use wood chunks.
- Wood chips should be level with top rim of wood chip bowl.
- Check wood chip bowl periodically to see if wood has burned down. Add more chips as needed.

CAUTION

When door is opened a flare up may occur. Should wood chips flare up, immediately close door, wait for wood chips to burn down then open door again. Do not spray with water.

ASSEMBLY INSTRUCTIONS

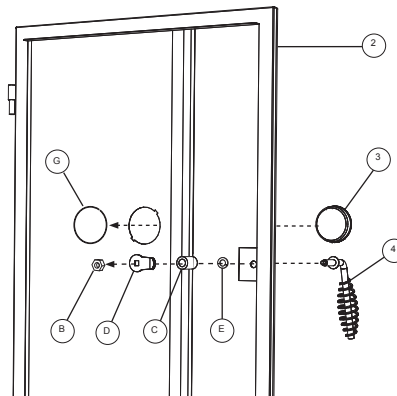

Step 3
 Insert temperature gauge (3) through slotted hole in smoker door (2) and secure into place with retainer ring (G).

Insert door handle (4) through smoker door (2). Place washer (E), handle bushing (C) and door latch (D) onto handle. Secure with lock nut (B) as illustrated.

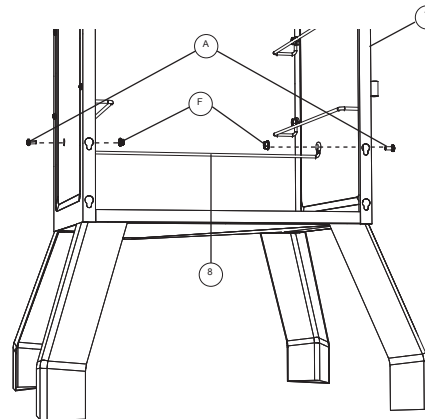

Step 4
 Place Element Support (8) into smoker body (1).

Secure with phillips head screw (A) and hex flange nut (F) as shown.

ASSEMBLY INSTRUCTIONS

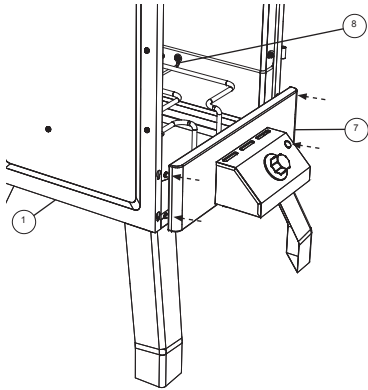

(*Some parts not shown for clarity.)

Step 5
Align control panel (7) with smoker body (1), rest element of control panel (7) onto element support (8).

Insert phillips head screws located on rear side of control panel (7) into hole slots of smoker body (1) as shown.

Tighten screws once nested securely into place.

ASSEMBLY INSTRUCTIONS

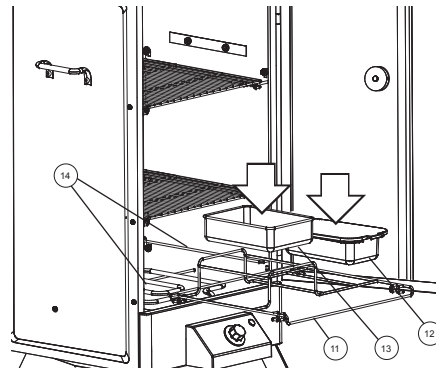

SOME PARTS NOT SHOWN FOR CLARITY.

Step 7
Set wood chip tray (12) and water bowl (13) into wood chip grate (11) and slide onto grate support (14) as shown.

Note: Wood chip tray and water bowl **MUST** be in place when using smoker. This minimizes the chance of wood flare ups.

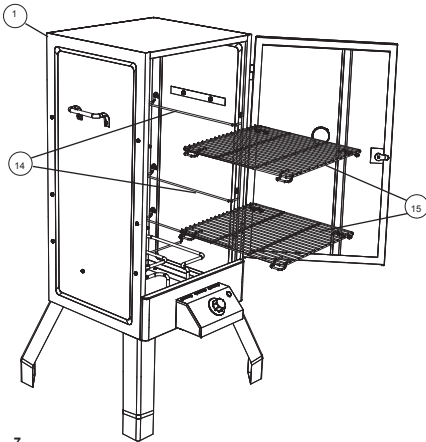

(*Some parts not shown for clarity.)

Step 6
Slide cooking grates (15) onto cooking grate supports (14) inside smoker body (1).

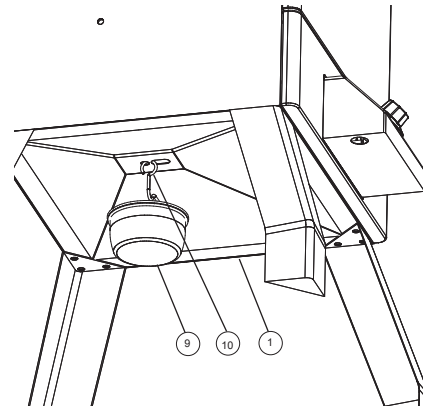

Step 8
Insert grease clip (10) with drip cup (9) into grooves under smoker body (1).