

This Owner's Manual is provided and hosted by [Appliance Factory Parts](http://www.appliancefactoryparts.com).



CARRIER FB4CNF030 Owner's Manual

[Shop genuine replacement parts for CARRIER
FB4CNF030](#)



[Find Your CARRIER HVAC Parts - Select From 102 Models](#)

----- Manual continues below -----

Installation Instructions

NOTE: Read the entire instruction manual before starting the installation.

TABLE OF CONTENTS

	PAGE
SAFETY CONSIDERATIONS	1
INTRODUCTION	1
HEATER PACKAGES	2
INSTALLATION	2
Step 1 — Check Equipment	2
Step 2 — Mount Unit	2
Step 3 — Air Ducts	4
Step 4 — Electrical Connections	4
Step 5 — Refrigerant Tubing Connection and Evacuation ..	7
Step 6 — Refrigerant Flow-Control Device	7
Step 7 — Condensate Drains	8
Step 8 — Accessories	9
Step 9 — Sequence of Operation	10
START-UP PROCEDURES	10
CARE AND MAINTENANCE	10
AIRFLOW PERFORMANCE TABLES	11

SAFETY CONSIDERATIONS

Improper installation, adjustment, alteration, service, maintenance, or use can cause explosion, fire, electrical shock, or other conditions which may cause death, personal injury or property damage. Consult a qualified installer, service agency, or your distributor or branch for information or assistance. The qualified installer or agency must use factory-authorized kits or accessories when modifying this product. Refer to the individual instructions packaged with kits or accessories when installing.

Follow all safety codes. Wear safety glasses, protective clothing and work gloves. Have a fire extinguisher available. Read these instructions thoroughly and follow all warnings or cautions included in literature and attached to the unit. Consult local building codes and the current editions of the National Electrical Code (NEC) NFPA 70.

In Canada, refer to the current editions of the Canadian Electrical Code CSA C22.1.

Recognize safety information. This is the safety-alert symbol . When you see this symbol on the unit and in instruction manuals, be alert to the potential for personal injury.

Understand the signal words **DANGER**, **WARNING**, and **CAUTION**. These words are used with the safety-alert symbol. **DANGER** identifies the most serious hazards which **will** result in severe personal injury or death. **WARNING** signifies hazards

which **could** result in personal injury or death. **CAUTION** is used to identify unsafe practices which **may** result in minor personal injury or product and property damage. **NOTE** is used to highlight suggestions which will result in enhanced installation, reliability, or operation.

WARNING

ELECTRICAL OPERATION HAZARD

Failure to follow this warning could result in personal injury or death.

Before installing or servicing unit, always turn off all power to unit. There may be more than 1 disconnect switch. Turn off accessory heater power if applicable. Lock out and tag switch with a suitable warning label.

CAUTION

CUT HAZARD

Failure to follow this caution may result in personal injury.

Sheet metal parts may have sharp edges or burrs. Use care and wear appropriate protective clothing and gloves when handling parts.

INTRODUCTION

Models FB4C and FY5B are Puron Fan Coils designed for installation flexibility. These units are designed to meet the low air leak requirements currently in effect.

FB4C uses a refrigerant piston metering device with an X-13 integral electronically commutated motor for efficiency. These units have been designed for upflow, downflow (kit required), and horizontal orientations, including manufactured and mobile home applications.

FY5B uses a refrigerant piston metering device (018 thru 048) with 2-speed PSC (permanent split capacitor) motors and TXV with 3-speed PSC motor for the 060 size. These units can be used for upflow or downflow (kit required) orientations, including manufactured and mobile homes applications.

These units require a field supplied air filter, and are designed specifically for Puron refrigerant air conditioners and heat pumps as shipped. These units are available for systems of 18,000 through 60,000 Btuh nominal cooling capacity. Factory-authorized, field-installed electric heater packages are available in sizes 5 through 30kW. See Product Data literature for all available accessory kits.

HEATER PACKAGES

This unit may or may not be equipped with an electric heater package. For units not equipped with factory-installed heat, a factory-approved, field-installed, UL listed heater package is available from your equipment supplier. See unit rating plate for a list of factory-approved heaters. Heaters that are not factory approved could cause damage which would not be covered under the equipment warranty. If fan coil contains a factory-installed heater package, minimum circuit ampacity (MCA) and maximum fuse/breaker may be different than units with a same size field-installed accessory heater. The differences is not an error and is due to calculation difference per UL guidelines.

INSTALLATION

Step 1 — Check Equipment

Unpack unit and move to final location. Remove carton taking care not to damage unit. Inspect equipment for damage prior to installation. File claim with shipping company if shipment is damaged or incomplete.

Locate unit rating plate which contains proper installation information. Check rating plate to be sure unit matches job specifications.

Step 2 — Mount Unit

Unit can stand or lie on floor, or hang from ceiling or wall. Allow space for wiring, piping, and servicing unit.

IMPORTANT: When unit is installed over a finished ceiling and/or living area, building codes may require a field-supplied secondary condensate pan to be installed under the entire unit. Some localities may allow as an alternative, the running of a separate, secondary condensate line. Consult local codes for additional restrictions or precautions.

A. Upflow Installation

If return air is to be ducted through a floor, set unit on floor over opening and use 1/8 to 1/4-in (3 to 6 mm) thick fireproof resilient gasket between duct, unit, and floor.

Side return is a field option on slope coil models. Cut opening per dimensions. (See Fig. 1.) A field-supplied bottom closure is required.

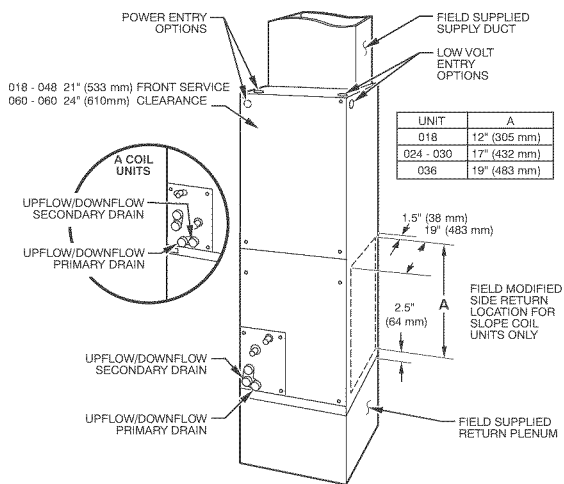

A07565

Fig. 1 - Slope Coil Unit in Upflow Application

B. Downflow Installation

In this application, field conversion of the evaporator is required using accessory downflow kit along with an accessory base kit. Use fireproof resilient gasket, 1/8 to 1/4-in (3 to 6 mm) thick, between duct, unit, and floor.

⚠ CAUTION

UNIT OR PROPERTY DAMAGE HAZARD

Failure to follow this caution may result in product or property damage.

The conversion of the fan coil to downflow requires special procedures for the condensate drains on both A-coil and slope units. The vertical drains have an overflow hole between the primary and secondary drain holes. This hole is plugged for all applications except downflow, but must be used for downflow. During the conversion process, remove the plastic cap covering the vertical drains only and discard. Remove the plug from the overflow hole and discard. At completion of the downflow installation, caulk around the vertical pan fitting to door joint to retain the low air leak performance of the unit.

NOTE: To convert units for downflow applications, refer to Installation Instructions supplied with kit for proper installation. For slope fan coils, use kit Part No. KFADC0201SLP. For A-coils, use kit Part No. KFADC0401ACL. Use fireproof resilient gasket, 1/8 to 1/4-in (3 to 6 mm) thick, between duct, unit, and floor.

NOTE: Gasket kit number KFAHD0101SLP is also required for all downflow applications to maintain low air leak/low sweat performance.

C. Horizontal Installation

Units must not be installed with access panels facing up or down. All other units are factory built for horizontal left installation. (See Fig. 2 and 3.) When suspending unit from ceiling, dimples in casing indicate suitable location of screws for mounting metal support straps. (See Fig. 2.)

⚠ CAUTION

PROPERTY DAMAGE HAZARD

Failure to follow this caution may result in product or property damage.

For optimum condensate drainage performance in horizontal installations, unit should be leveled along its length and width.

For horizontal applications having high return static and humid return air, the Water Management Kit, KFAHC0125AAA, may need to be used to assist in water management.

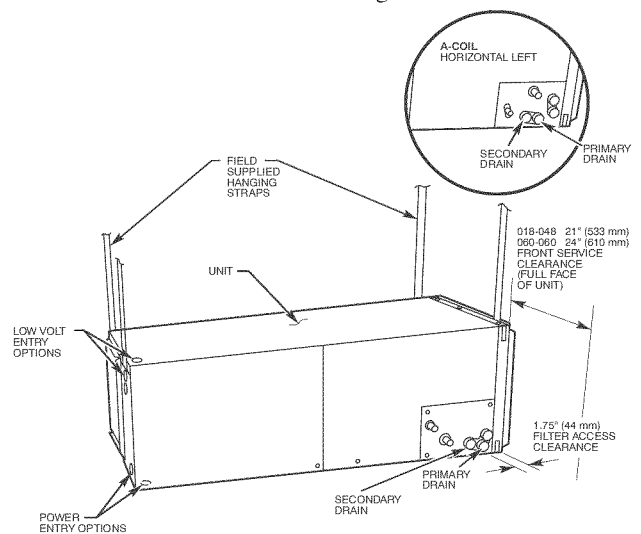

A07566

Fig. 2 - Slope Coil Unit in Horizontal Left Application

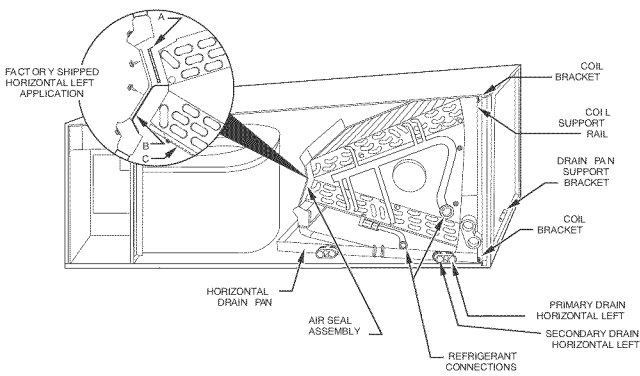

Fig. 3 - A-Coil in Horizontal Left Application (Factory Ready)

NOTE: Modular units can be disassembled and components moved separately to installation area for reassembly. This process accommodates small scuttle holes and limiting entrances to installation sites. (See Fig. 4.)

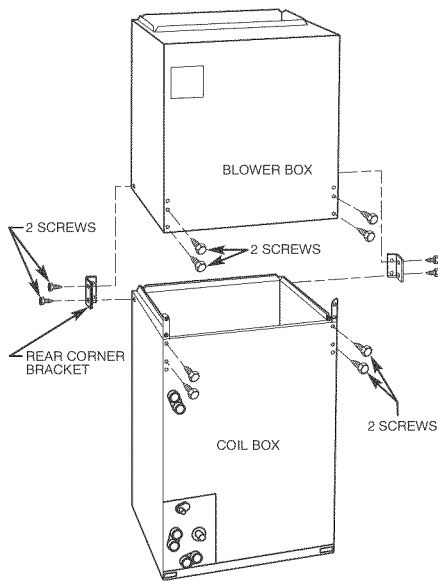

Fig. 4 - Removal of Brackets on Modular Units

Horizontal Right Conversion of Units With Slope Coils
NOTE: Gasket kit number KFAHD0101SLP is required for horizontal slope coil conversion to maintain low air leak/low sweat performance.

1. Remove blower and coil access panel and fitting panel. (See Fig. 5.)
2. Remove coil mounting screw securing coil assembly to right side casing flange.
3. Remove coil assembly.
4. Lay fan coil unit on its right side and reinstall coil assembly with condensate pan down. (See Fig. 5.)
5. Attach coil to casing flange using coil mounting screw previously removed.
6. Make sure the pan cap in the fitting door is properly seated on the fitting door to retain the low air leak rating of the unit.
7. Add gaskets from kit KFAHD per kit instructions.
8. Align holes with tubing connections and condensate pan connections, and reinstall access panels and fitting panel.

Make sure liquid and suction tube grommets are in place to prevent air leaks and cabinet sweating. Install after brazing.

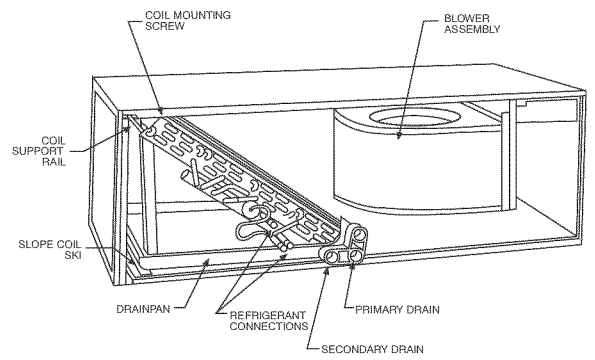

Fig. 5 - Conversion for Horizontal Right Applications Using a Slope Coil

Horizontal Right Conversion of Units With A-Coils

1. Remove blower and coil access panels. (See Fig. 6.)

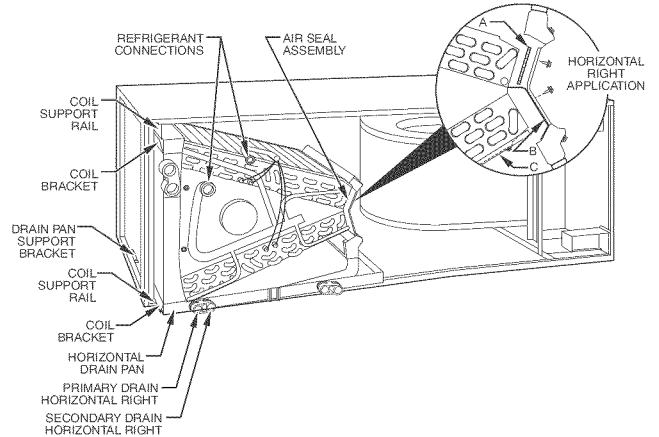

Fig. 6 - Conversion for Horizontal Right Applications Using A-Coil

2. Remove metal clip securing fitting panel to condensate pan. Remove fitting panel.
3. Remove 2 snap-in clips securing A-coil in unit.
4. Slide coil and pan assembly out of unit.
5. Remove horizontal drain pan support bracket from coil support rail on left side of unit and reinstall on coil support rail on right side of unit. (See Fig. 7.)

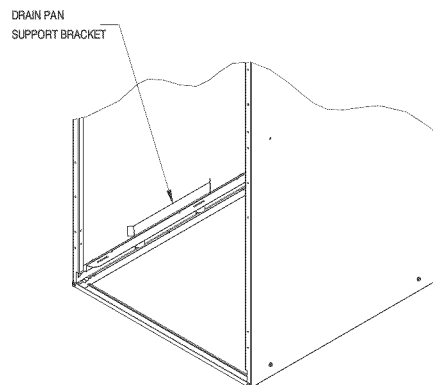

Fig. 7 - Drain Pan Support Bracket

6. Convert air-seal assembly for horizontal right.
 - a. Remove air-seal assembly from coil by removing 4 screws. (See Fig. 6.)
 - b. Remove air splitter (B) from coil seal assembly by removing 3 screws. (See Fig. 3-factory shipped inset.)

- c. Remove filter plate (A) and install air splitter (B) in place of filter plate.
 - d. Install filter plate (A) as shown in horizontal right application.
 - e. Remove condensate troughs (C) and install on opposite tube sheets.
 - f. Install hose onto plastic spout.
7. Install horizontal pan on right side of coil assembly.
 8. Slide coil assembly into casing. Be sure coil bracket on each corner of vertical pan engages coil support rails.
 9. Reinstall 2 snap-in clips to correctly position and secure coil assembly in unit. Be sure clip with large offsets is used on right side of unit to secure horizontal pan.
 10. Remove two oval fitting caps from the left side of the coil door and fitting panel.
 11. Remove insulation knockouts on right side of coil access panel.
 12. Remove 2 oval coil access panel plugs and reinstall into holes on left side of coil access panel and fitting panel.
 13. Install condensate pan fitting caps (from item 10) in the right side of the coil door making sure that the cap snaps and seats cleanly on the back side of the coil door. Make sure no insulation interferes with seating of the cap.
 14. Reinstall access fitting panels, aligning holes with tubing connections and condensate pan connections. Be sure to reinstall metal clip between fitting panel and vertical condensate pan.

Make sure liquid and suction tube grommets are in place to prevent air leaks and cabinet sweating.

D. Manufactured and Mobile Home Housing Applications

1. Fan coil unit must be secured to the structure using field-supplied hardware.
2. Allow a minimum of 24-in (610 mm) clearance from access panels.
3. Recommended method of securing for typical applications:
 - a. If fan coil is away from wall, attach pipe strap to top of fan coil using no. 10 self-tapping screws. Angle strap down and away from back of fan coil, remove all slack, and fasten to wall stud of structure using 5/16-in. lag screws. Typical both sides of fan coil.

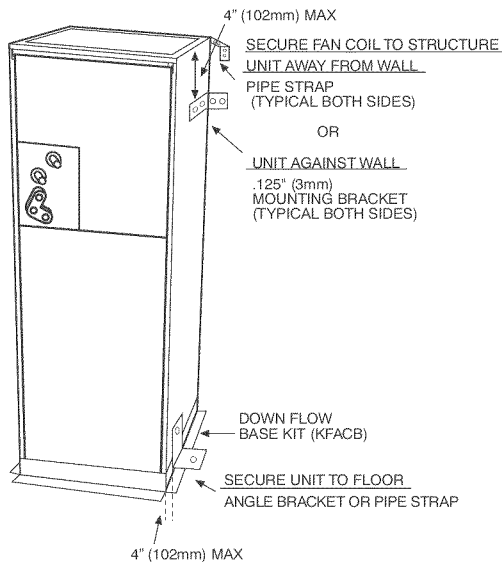

Fig. 8 - A-Coil

A07567

- b. If fan coil is against wall, secure fan coil to wall stud using 1/8-in (3 mm) thick right-angle brackets. Attach brackets to fan coil using no. 10 self-tapping screws and to wall stud using 5/16-in. lag screws. (See Fig. 8.)

Step 3 — Air Ducts

Connect supply-air duct over the outside of 3/4-in (19 mm) flanges provided on supply-air opening. Secure duct to flange, using proper fasteners for type of duct used, and seal duct-to-unit joint. If return-air flanges are required, install factory-authorized accessory kit.

Use flexible connectors between ductwork and unit to prevent transmission of vibration. When electric heater is installed, use heat-resistant material for flexible connector between ductwork and unit at discharge connection. Ductwork passing through unconditioned space must be insulated and covered with vapor barrier.

Units equipped with 20–30kW electric heaters require a 1-in (25 mm) clearance to combustible materials for the first 36-in (914 mm) of supply duct.

Ductwork Acoustical Treatment

Metal duct systems that do not have a 90° elbow and 10-ft (3m) of main duct to first branch takeoff may require internal acoustical insulation lining. As an alternative, fibrous ductwork may be used if constructed and installed in accordance with the latest edition of SMACNA construction standard on fibrous glass ducts. Both acoustical lining and fibrous ductwork shall comply with National Fire Protection Association as tested by UL Standard 181 for Class 1 air ducts.

Step 4 — Electrical Connections

FY5B units from the factory utilize a printed-circuit board (PCB) which has a low voltage circuit protective fuse (5 amp), fan motor speed tap selection terminal (SPT), and time delay relay (TDR) jumper. To disable the TDR feature, sever the jumper wire JW1.

FB4C units from the factory protect the low voltage circuit with a 3 amp automotive type fuse inline on the wire harness and Does Not contain a circuit board. Motor speeds and time delay function are built into the motor (see section E for clarification).

When a factory-approved accessory control package has been installed, check all factory wiring per unit wiring diagram and inspect factory wiring connections to be sure none were loosened in transit or installation. If a different control package is required, see unit rating plate.

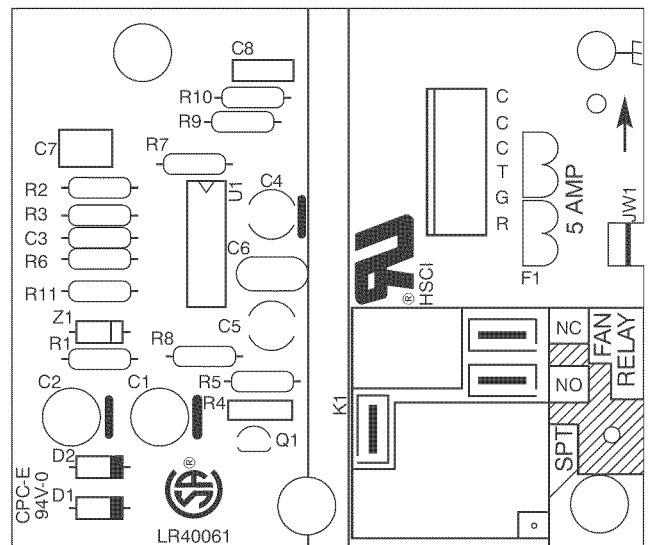

Fig. 9 - Fan Coil Printed Circuit Board for FY5B Model

A03010

⚠ CAUTION

PROPERTY DAMAGE HAZARD

Failure to follow this caution may result in product or property damage.

If a disconnect switch is to be mounted on unit, select a location where drill or fastener will not contact electrical or refrigerant components.

Before proceeding with electrical connections, make certain that supply voltage, frequency, phase, and ampacity are as specified on the unit rating plate. See unit wiring label for proper field high- and low-voltage wiring. Make all electrical connections in accordance with the NEC and any local codes or ordinances that may apply. Use copper wire only.

The unit must have a separate branch electric circuit with a field-supplied disconnect switch located within sight from, and readily accessible from, the unit.

On units with a factory-installed disconnect with pull-out removed, service and maintenance can be safely performed on only the load side of the control package.

⚠ WARNING

ELECTRICAL SHOCK HAZARD

Failure to follow this warning could result in personal injury or death.

Field wires on the line side of the disconnect found in the fan coil unit remain live, even when the pull-out is removed. Service and maintenance to incoming wiring cannot be performed until the main disconnect switch (remote to the unit) is turned off.

A. Line Voltage Connections

If unit will contain accessory electric heater, remove and discard power plug from fan coil and connect male plug from heater to female plug from unit wiring harness. (See Electric Heater Installation Instructions.)

For units without electric heater:

1. Connect 208/230v power leads from field disconnect to yellow and black stripped leads.
2. Connect ground wire to unit ground lug.

NOTE: Units installed without electric heat should have a field-supplied sheet metal block-off plate covering the heater opening. This will reduce air leakage and formation of exterior condensation.

B. 24-v Control System

Connection To Unit

Wire low voltage in accordance with wiring label on the blower. (See Fig. 10 through 15.) Use no. 18 AWG color-coded, insulated (35°C minimum) wire to make the low-voltage connections between the thermostat, the unit, and the outdoor equipment. If the thermostat is located more than 100-ft (30 m) from the unit (as measured along the low-voltage wire), use no. 16 AWG color-coded, insulated (35°C minimum) wire. All wiring must be NEC Class 1 and must be separated from incoming power leads.

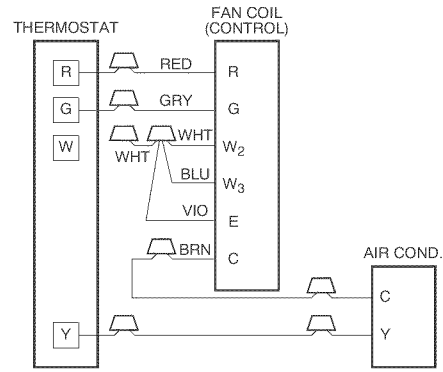

Fig. 10 - Wiring Layout Air Conditioning Unit (Cooling Only)

A94058

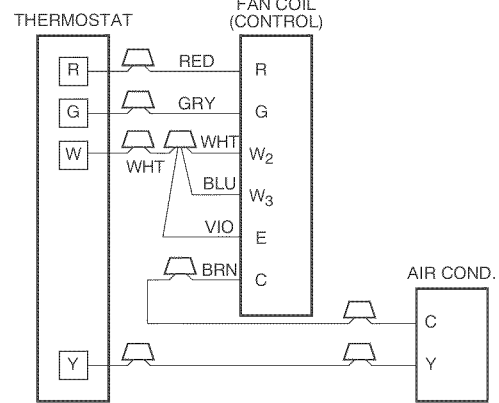

Fig. 11 - Wiring Layout Air Conditioning Unit (Cooling and 1-Stage Heat)

A94059

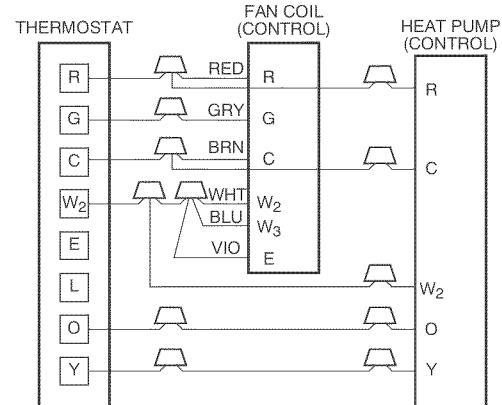
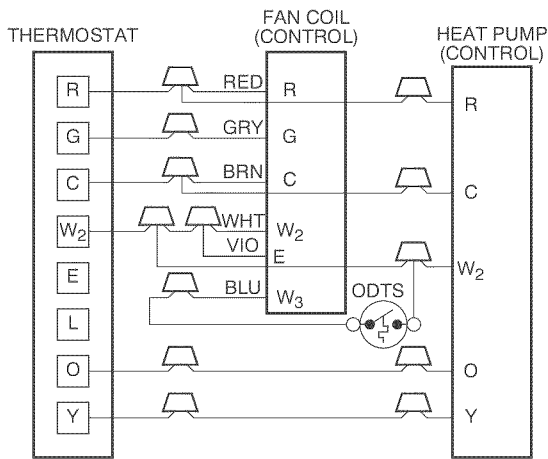

Fig. 12 - Wiring Layout Heat Pump Unit (Cooling and 2-Stage Heat with No Outdoor Thermostat)

A94060



**Fig. 13 - Wiring Layout Heat Pump Unit
(Cooling and 2-Stage Heat with
1 Outdoor Thermostat)**

A94061

Transformer Information

Transformer is factory-wired for 230v operation. For 208v applications, disconnect the black wire from the 230v terminal on transformer and connect it to the 208v terminal. (See Fig. 16.)

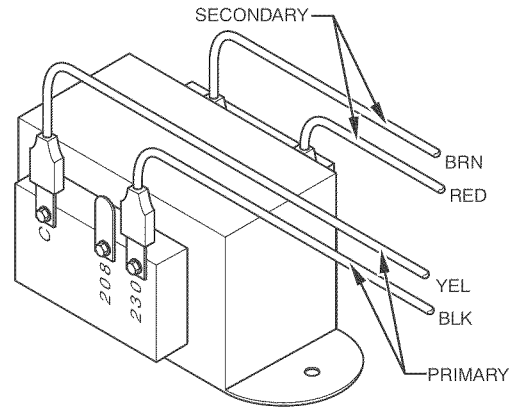
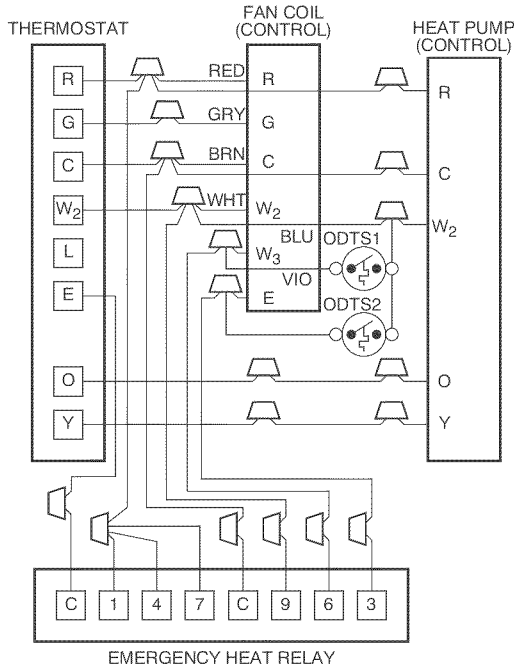

Fig. 16 - Transformer Connections

A05182



**Fig. 14 - Wiring Layout Heat Pump Unit (Cooling and
2-Stage Heat with 2 Outdoor Thermostats)**

A94062

Heater Staging

▲ CAUTION

PROPERTY DAMAGE HAZARD

Failure to follow this caution may result in product or property damage.

If W2, W3, and E on any 3 stage heater (18, 20, 24, or 30kW) are individually connected as with outdoor thermostats or any other situation, emergency heat relay must be used. This relay is in kit Part No. KHOT0201SEC and is normally used with kit Part No. KHAOT0301FST for 2 outdoor thermostat systems.

The controls are factory circuited for single-stage operation. For 2-stage operation, use outdoor thermostat kit Part No. KHAOT0301FST, and for 3-stage use both kits Part No. KHAOT0201SEC and KHAOT0301FST.

When 2 stages are desired, cut W3 at the W2 wire nut, strip and reconnect per the thermostat kit instruction. (See Fig. 14.) When 3 stages are desired, cut the W2 wire nut off and discard. Strip W2, W3, and E and reconnect per thermostat kit instructions. (See Fig. 14.)

NOTE: When 3 stages are used or anytime the E terminal is not tied to W2, the emergency heat relay, part of outdoor kit Part No. KHAOT0201SEC must be used.

C. Manufactured Housing

In manufactured housing applications, the Code of Federal Regulations, Title 24, Chapter XX, Part 3280.714 requires that supplemental electric heat be locked out at outdoor temperatures above 40°F (4°C), except for a heat pump defrost cycle. Refer to Fig. 15 for typical low voltage wiring with outdoor thermostat.

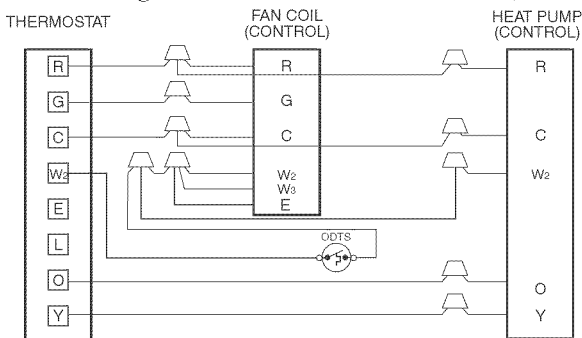

**Fig. 15 - Wiring Layout Heat Pump Unit
(Cooling and 2-Stage Heat for Manufactured Housing)**

A03088

Refer to outdoor unit wiring instructions for any additional wiring procedure recommendations.

D. Ground Connections

⚠️ WARNING

ELECTRICAL SHOCK HAZARD

Failure to follow this warning could result in personal injury or death.

According to NEC, ANSI/NFPA 70, and local codes, the cabinet must have an uninterrupted or unbroken ground to minimize personal injury if an electrical fault should occur. The ground may consist of electrical wire or metal conduit when installed in accordance with existing electrical codes. If conduit connection uses reducing washers, a separate ground wire must be used.

NOTE: Use UL-listed conduit and conduit connector for connecting supply wire(s) to unit to obtain proper grounding. Grounding may also be accomplished by using grounding lugs provided in control box.

E. Minimum CFM and Motor Speed Selection

Units with or without electric heaters require a minimum CFM. Refer to the unit wiring label to ensure that the fan speed selected is not lower than the minimum fan speed indicated.

FY5B fan speed selection is done at the fan relay printed-circuit board. To change motor speeds, disconnect fan lead used on relay terminal (SPT) and replace with motor speed tap desired. (See Fig. 17.) Save insulating cap and place on motor lead removed from relay.

NOTE: In low static applications, lower motor speed tap should be used to reduce possibility of water being blown off coil.

FY5B have 2 motor speed taps. Low speed (red) and high speed (black). The 060 size only will have a Medium speed (blue).

See Table 2 - FY5B Airflow Performance (CFM), for each setting.

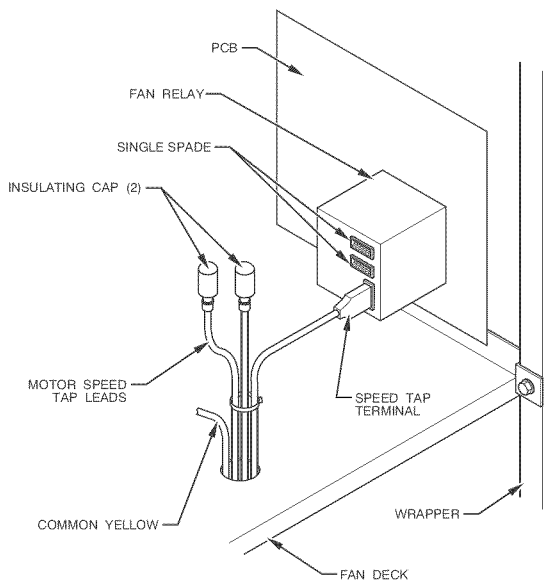

A97529

Fig. 17 - Fan Coil Relay and Speed Tap Terminal for FY5B Models

The fan speed selection on the FB4C models is done at the motor. Units with or without electric heaters require a minimum CFM. Refer to the unit wiring label to ensure that the fan speed selected is not lower than the minimum fan speed indicated. To change motor speeds disconnect the BLUE fan lead from terminal #2 (factory default position) and move to desired speed-tap; 1, 2, 3, or 5. Speed-taps 1, 2, and 3 have a 90 second blower time delay pre-programmed into the motor. Speed tap 4 is used for electric

heat only (with 0 second blower time delay) and the WHITE wire must remain on tap 4. Speed-tap 5 is used for high static applications, but has a 0 second blower time delay pre-programmed into the motor (see Table 1 - FB4C Airflow Performance (CFM), for each tap setting. Also, see Fig. 18 for motor speed selection location.

NOTE: In low static applications, lower motor speed tap should be used to reduce possibility of water being blown off coil.

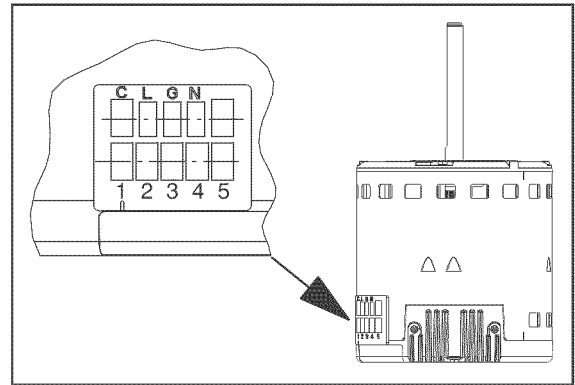

A09390

Fig. 18 - Motor Speed Selection

Step 5 — Refrigerant Tubing Connection and Evacuation

Use accessory tubing package or field-supplied tubing of refrigerant grade. Suction tube must be insulated. Do not use damaged, dirty, or contaminated tubing because it may plug refrigerant flow-control device. ALWAYS evacuate the coil and field-supplied tubing to 500 microns before opening outdoor unit service valves.

⚠️ CAUTION

PRODUCT DAMAGE HAZARD

Failure to follow this caution may result in product or property damage.

A brazing shield **MUST** be used when tubing sets are being brazed to the unit connections to prevent damage to the unit surface and condensate pan fitting caps.

Units have sweat suction and liquid tube connections. Make suction tube connection first.

1. Cut tubing to correct length.
2. Insert tube into sweat connection on unit until it bottoms.
3. Braze connection using silver bearing or non-silver bearing brazing materials. Do not use solder (materials which melt below 800°F / 427°C). Consult local code requirements.
4. Evacuate coil and tubing system to 500 microns using deep vacuum method.

⚠️ CAUTION

PRODUCT DAMAGE HAZARD

Failure to follow this caution may result in product or property damage.

Wrap a wet cloth around rear of fitting to prevent damage to piston assembly or TXV and factory-made joints.

Step 6 — Refrigerant Flow-Control Device

FB4C units come equipped with a factory installed Piston with Teflon ring metering device (sizes 018 thru 060). If a piston replacement is required, check piston size shown on indoor unit

rating plate to see if it matches required piston shown on outdoor unit rating plate. If it does not match, replace indoor piston with piston shipped with outdoor unit. The piston shipped with outdoor unit is correct for any approved indoor coil combination (See Fig. 19). When changing piston, use a back-up wrench. Hand tighten hex nut, then tighten with wrench 1/2 turn. Do not exceed 30 ft-lbs.

NOTE: The indoor piston contains a Teflon ring (or seal) which is used to seat against the inside of distributor body, and must be installed properly to ensure proper seating in the direction for cooling operation.

FY5B units also contain a factory installed Piston with Teflon ring for sizes 018 thru 048 only. The FY5B-060 size units come equipped with a Puron refrigerant TXV.

Always use outdoor units designed to match indoor fan coil applications.

FB4C / FY5B

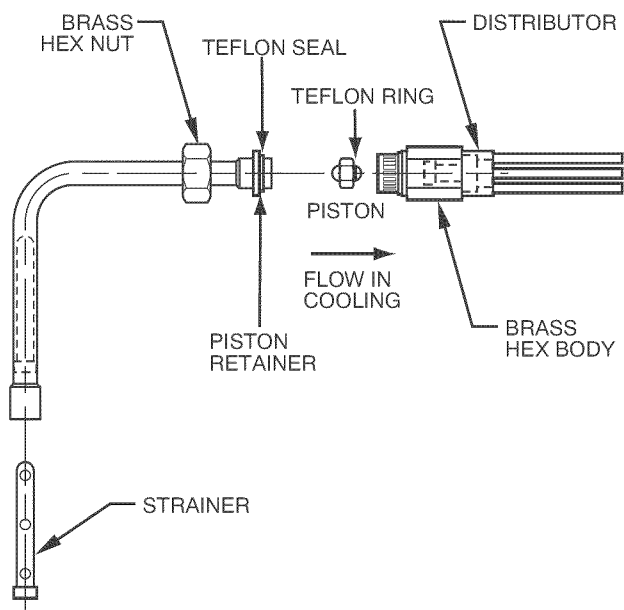

Fig. 19 - Refrigerant Flow - Control Device

A09677

⚠ CAUTION

PRODUCT OPERATION HAZARD

Failure to follow this caution may result in improper product operation.

If using a TXV in conjunction with a single-phase reciprocating compressor, a compressor start capacitor and relay are required. Consult outdoor unit pre-sale literature for start assist kit part number.

Step 7 — Condensate Drains

To connect drains, the cap openings must be removed. Use a knife to start the opening near the tab and using pliers, pull the tab to remove the disk. Clean the edge of the opening if necessary and install the condensate line. Finally caulk around the lines where they exit the fitting to retain the low leak rating of the unit.

⚠ CAUTION

UNIT OR PROPERTY DAMAGE HAZARD

Failure to follow this caution may result in product or property damage.

The conversion of the fan coil to downflow requires special procedures for the condensate drains on both A-coil and slope units. The vertical drains have an overflow hole between the primary and secondary drain holes. This hole is plugged for all applications except downflow, but must be used for downflow. During the conversion process, remove the plastic cap covering the vertical drains only and discard. Remove the plug from the overflow hole and discard. At completion of the downflow installation, caulk around the vertical pan fitting to door joint to retain the low air leak performance of the unit.

Units are equipped with primary and secondary 3/4-in. FPT drain connections. For proper condensate line installations see Fig. 1, 2, 3, 5 and 6. To prevent property damage and achieve optimum drainage performance, BOTH primary and secondary drain lines should be installed and include properly-sized condensate traps. (See Fig. 20 and 21.) Factory-approved condensate traps are available. It is recommended that PVC fittings be used on the plastic condensate pan. Finger-tighten plus 1-1/2 turns. Do not over-tighten. Use pipe dope.

⚠ CAUTION

PROPERTY DAMAGE HAZARD

Failure to follow this caution may result in product or property damage.

Shallow running traps are inadequate and DO NOT allow proper condensate drainage. (See Fig. 22.)

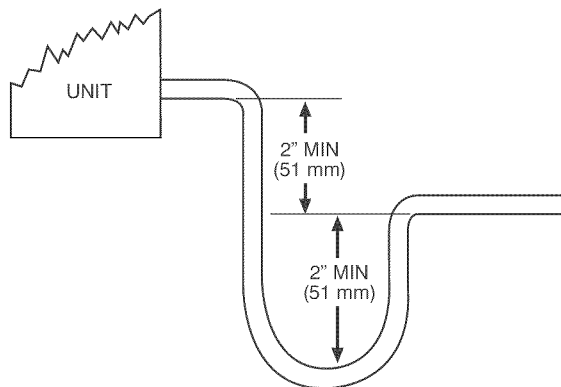

Fig. 20 - Recommended Condensate Trap

A03002

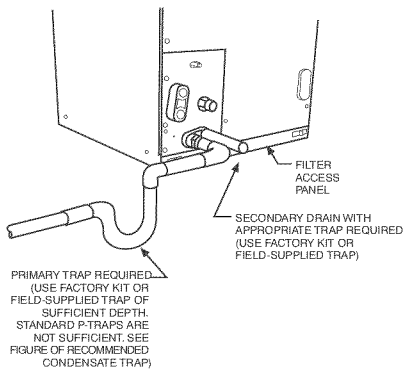
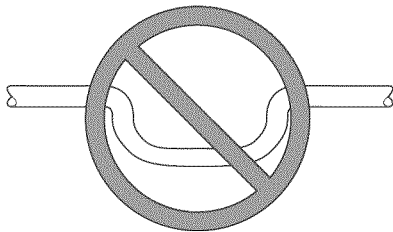

Fig. 21 - Condensate Trap and Unit



DO NOT USE SHALLOW RUNNING TRAPS!

Fig. 22 - Insufficient Condensate Trap

NOTE: When connecting condensate drain lines, avoid blocking filter access panel, thus preventing filter removal. After connection, prime both primary and secondary condensate traps.

NOTE: If unit is located in or above a living space where damage may result from condensate overflow, a field-supplied, external condensate pan should be installed underneath the entire unit, and a secondary condensate line (with appropriate trap) should be run from the unit into the pan. Any condensate in this external condensate pan should be drained to a noticeable place. As an alternative to using an external condensate pan, some localities may allow the use of a separate 3/4-in (19 mm) condensate line (with appropriate trap) to a place where the condensate will be noticeable. The owner of the structure must be informed that when condensate flows from the secondary drain or external condensate pan, the unit requires servicing or water damage will occur.

Install traps in the condensate lines as close to the coil as possible. (See Fig. 21.) Make sure that the outlet of each trap is below its connection to the condensate pan to prevent condensate from overflowing the drain pan. Prime all traps, test for leaks, and insulate traps if located above a living area. Condensate drain lines should be pitched downward at a minimum slope of 1-in (25 mm) for every 10-ft (3 m) of length. Consult local codes for additional restrictions or precautions.

Step 8 — Accessories

A. Electronic Air Cleaner

The Electronic Air Cleaner may be connected to fan coil as shown in Fig. 23. This method requires a field supplied transformer. See Electronic Air Cleaner literature for kit requirements.

B. Humidifier

Connect humidifier and humidistat to fan coil unit as shown in Fig. 24 and Fig. 25. The cooling lockout relay is optional.

A03003

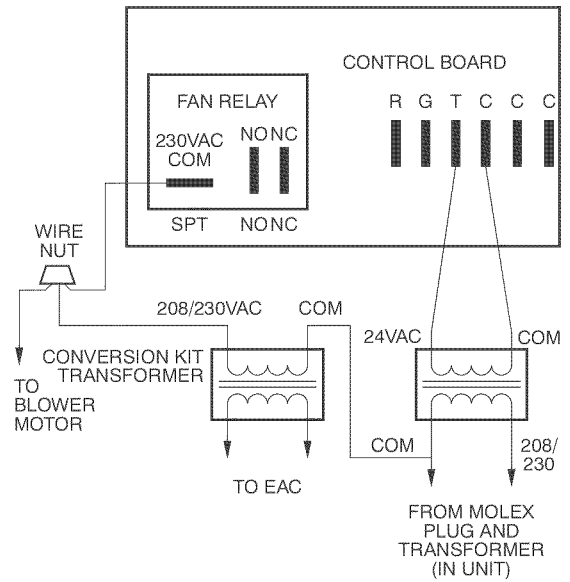

Fig. 23 - Wiring Layout of Electronic Air Cleaner to Fan Coil for FY5B Models Only

A03011

A03013

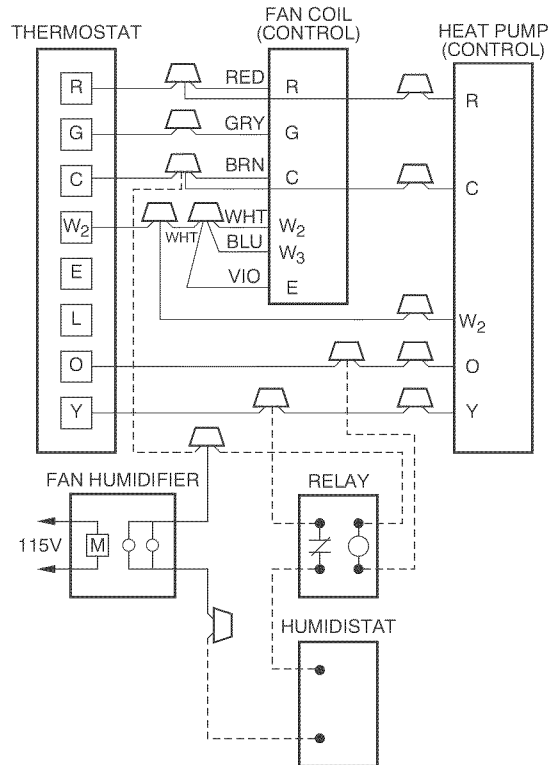

Fig. 24 - Wiring Layout of Humidifier to Heat Pump

A05294

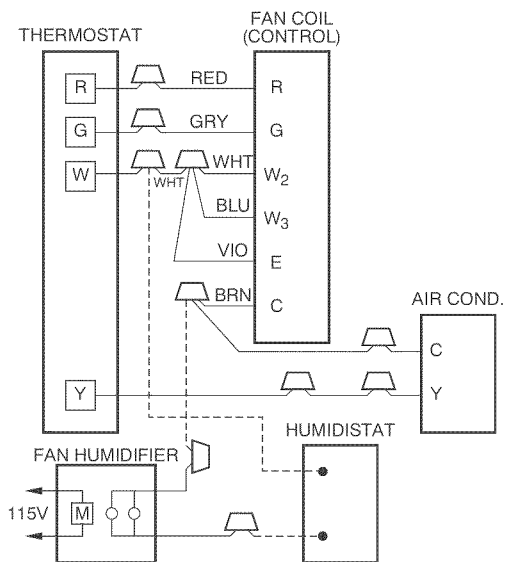

Fig. 25 - Wiring Layout of Humidifier to Fan Coil With Electric Heat

A95295

Step 9 — Sequence of Operation

A. Continuous Fan

Thermostat closes R to G. G energizes fan relay on PCB which completes circuit to indoor blower motor. When G is de-energized, there is a 90-sec delay before relay opens.

B. Cooling Mode

Thermostat energizes R to G, R to Y, and R to O (heat pump only). G energizes fan relay on PCB which completes circuit to indoor blower motor. When G is de-energized, there is a 90-sec delay before fan relay opens.

C. Heat Pump Heating with Auxiliary Electric Heat

Thermostat energizes R to G, R to Y, and R to W. G energizes fan relay on PCB which completes circuit to indoor blower motor. W energizes electric heat relay(s) which completes circuit to heater element(s). When W is de-energized, electric heat relay(s) open, turning off heater elements. When G is de-energized there is a 90-sec delay before fan relay opens.

D. Electric Heat or Emergency Heat Mode

Thermostat closes R to W. W energizes electric heat relay(s) which completes circuit to heater element(s). Blower motor is energized through normally closed contacts on fan relay. When W is de-energized, electric heat relay(s) opens.

START-UP PROCEDURES

Refer to outdoor unit Installation Instructions for system start-up instructions and refrigerant charging method details.

CAUTION

UNIT COMPONENT HAZARD

Failure to follow this caution may result in product damage.

Never operate unit without a filter. Damage to blower motor or coil may result. Factory authorized filter kits must be used when locating the filter inside the unit. For those applications where access to an internal filter is impractical, a field-supplied filter must be installed in the return duct system.

CARE AND MAINTENANCE

To continue high performance and minimize possible equipment failure, it is essential that periodic maintenance be performed on this equipment. Consult your local dealer as to the proper frequency of maintenance contract.

The ability to properly perform maintenance on this equipment requires certain mechanical skills and tools. If you do not possess these, contact your dealer for maintenance. The only consumer service recommended or required is filter replacement or cleaning on a monthly basis.

AIRFLOW PERFORMANCE TABLES

Table 1 – FB4C Airflow Performance (CFM)

MODEL & SIZE	BLOWER SPEED	0.10	0.20	0.30	0.40	0.50	0.60
		FB4C 018	Tap 5	767	739	702	669
	Tap 4	614	569	534	486	436	398
	Tap 3	701	660	616	581	537	499
	Tap 2	614	569	534	486	436	398
	Tap 1	614	569	534	486	436	398
FB4C 024	Tap 5	969	936	892	835	763	676
	Tap 4	826	795	766	743	706	660
	Tap 3	826	795	766	743	706	660
	Tap 2	701	660	616	581	537	499
	Tap 1	617	592	552	507	472	420
FB4C 030	Tap 5	1108	1090	1065	1034	1009	974
	Tap 4	1026	1000	969	938	899	865
	Tap 3	1026	1000	969	938	899	865
	Tap 2	909	873	842	799	762	724
	Tap 1	825	795	757	722	674	634
FB4C 036	Tap 5	1301	1276	1245	1218	1176	1121
	Tap 4	1227	1191	1169	1143	1105	1074
	Tap 3	1227	1191	1169	1143	1105	1074
	Tap 2	1087	1062	1030	1001	966	930
	Tap 1	1026	1000	969	938	899	865
FB4C 042	Tap 5	1560	1544	1507	1464	1424	1358
	Tap 4	1419	1397	1358	1320	1279	1239
	Tap 3	1419	1397	1358	1320	1279	1239
	Tap 2	1249	1220	1184	1142	1093	1052
	Tap 1	1242	1205	1158	1110	1069	1026
FB4C 048	Tap 5	1743	1712	1679	1642	1610	1574
	Tap 4	1669	1634	1599	1564	1531	1499
	Tap 3	1669	1634	1599	1564	1531	1499
	Tap 2	1452	1413	1377	1339	1308	1271
	Tap 1	1300	1256	1221	1182	1142	1101
FB4C 060	Tap 5	1897	1867	1836	1808	1774	1736
	Tap 4	1817	1785	1757	1724	1693	1655
	Tap 3	1817	1785	1757	1724	1693	1655
	Tap 2	1657	1621	1589	1557	1518	1474
	Tap 1	1443	1412	1377	1332	1286	1243

Table 2 – FY5B Airflow Performance (CFM)

MODEL & SIZE	BLOWER SPEED	0.10		0.20		0.30		0.40		0.50		0.60	
		208V	230V	208V	230V	208V	230V	208V	230V	208V	230V	208V	230V
FY5B 018	High	742	825	707	768	642	714	568	648	466	526	403	434
	Low	541	608	480	564	417	511	357	431	299	363	n/a	304
FY5B 024	High	1041	1112	969	1030	888	936	774	791	573	654	341	438
	Low	874	1014	838	953	781	868	684	740	506	573	341	418
FY5B 030	High	1256	1327	1186	1242	1071	1132	952	1005	704	791	459	482
	Low	965	1117	949	1074	916	1019	805	902	575	637	396	447
FY5B 036	High	1306	1490	1264	1418	1207	1338	1135	1241	1043	1127	842	937
	Low	1164	1335	1144	1290	1108	1226	1052	1148	970	1048	697	855
FY5B 042	High	1723	1768	1639	1681	1544	1576	1435	1465	1309	1340	1144	1182
	Low	1387	1543	1358	1488	1311	1410	1237	1315	1137	1200	997	1047
FY5B 048	High	1902	1941	1803	1867	1706	1767	1593	1648	1472	1512	1303	1371
	Low	1671	1777	1630	1711	1563	1630	1479	1528	1370	1412	1218	1266
FY5B 060	High	2064	2128	1989	2050	1906	1965	1819	1875	1725	1778	1624	1674
	Medium	1812	1959	1756	1898	1692	1829	1619	1750	1538	1663	1449	1566
	Low	1556	1748	1521	1709	1477	1659	1422	1598	1357	1525	1283	1442

■ – Airflow outside 450 cfm/ton.

NOTES:

- Airflow based upon dry coil at 230v with factory-approved filter and electric heater (2 element heater sizes 018 through 036, 3 element heater sizes 042 through 060). For FB4C models, airflow at 208 volts is approximately the same as 230 volts because the X13 motor is a constant torque motor. The torque doesn't drop off at the speeds the motor operates.
- To avoid potential for condensate blowing out of drain pan prior to making drain trap:
Return static pressure must be less than 0.40 in. wc.
Horizontal applications of 042 - 060 sizes must have supply static greater than 0.20 in. wc.
- Airflow above 400 cfm/ton on 048-060 size could result in condensate blowing off coil or splashing out of drain pan.

Table 3 – FB4C Air Delivery Performance Correction Component Pressure Drop (in. wc) at Indicated Airflow (Dry to Wet Coil)

UNIT SIZE	CFM															
	500	600	700	800	900	1000	1100	1200	1300	1400	1500	1600	1700	1800	1900	2000
018	0.034	0.049	0.063	--	--	--	--	--	--	--	--	--	--	--	--	--
024	0.034	0.049	0.063	0.076	0.089	--	--	--	--	--	--	--	--	--	--	--
030	--	--	--	0.049	0.059	0.070	0.080	--	--	--	--	--	--	--	--	--
036	--	--	--	--	--	0.070	0.080	0.090	0.099	--	--	--	--	--	--	--
042	--	--	--	--	--	--	--	0.049	0.056	0.063	0.070	--	--	--	--	--
048	--	--	--	--	--	--	--	--	--	0.063	0.070	0.076	0.083	0.090	--	--
060	--	--	--	--	--	--	--	--	--	--	--	0.049	0.054	0.059	0.065	0.070

Table 4 – FY5B Air Delivery Performance Correction Component Pressure Drop (in. wc) at Indicated Airflow (Dry to Wet Coil)

UNIT SIZE	CFM															
	500	600	700	800	900	1000	1100	1200	1300	1400	1500	1600	1700	1800	1900	2000
018	0.016	0.027	0.038	--	--	--	--	--	--	--	--	--	--	--	--	--
024	0.016	0.027	0.038	0.049	0.059	--	--	--	--	--	--	--	--	--	--	--
030	--	--	--	0.036	0.046	0.055	0.064	--	--	--	--	--	--	--	--	--
036	--	--	--	--	--	0.055	0.064	0.073	0.081	--	--	--	--	--	--	--
042	--	--	--	--	--	--	--	0.049	0.056	0.063	0.070	--	--	--	--	--
048	--	--	--	--	--	--	--	--	--	0.038	0.043	0.049	0.054	0.059	--	--
060	--	--	--	--	--	--	--	--	--	--	--	0.031	0.036	0.040	0.044	0.049

Table 5 – FB4C Electric Heater Static Pressure Drop (in. wc)

UNIT SIZE	CFM									
	400	600	800	1000	1200	1400	1600	1800	2000	
018, 024	0.020	0.044	0.075	--	--	--	--	--	--	
030, 036	--	--	0.048	0.072	0.100	--	--	--	--	
042, 048, 060	--	--	--	--	0.070	0.092	0.120	0.152	--	

Table 6 – FY5B Electric Heater Static Pressure Drop (in. wc)

UNIT SIZE	CFM									
	400	600	800	1000	1200	1400	1600	1800	2000	
018, 024	0.020	0.044	0.075	0.110	0.100	--	--	--	--	
030, 036, 042	--	--	0.048	0.072	0.100	0.130	0.120	--	--	
048, 060	--	--	--	--	--	0.092	0.120	0.152	0.187	

Table 7 – Electric Heater Static Pressure Drop (in. wc)

FB4C, FY5B 018 – 036			FB4C, FY5B 042 – 060		
HEATER ELEMENTS	kW	EXTERNAL STATIC PRESSURE CORRECTION	HEATER ELEMENTS	kW	EXTERNAL STATIC PRESSURE CORRECTION
0	0	+.02	0	0	+.04
1	3, 5	+.01	2	8, 10	+.02
2	8, 10	0	3	9, 15	0
3	9, 15	-.02	4	20	-.02
4	20	-.04	6	18, 24, 30	-.10

FB4C / FY5B

PURON® (R-410A) QUICK REFERENCE GUIDE

- Puron refrigerant operates at 50-70 percent higher pressures than R-22. Be sure that servicing equipment and replacement components are designed to operate with Puron refrigerant.
- Puron refrigerant cylinders are rose colored.
- Recovery cylinder service pressure rating must be 400 psig, DOT 4BA400 or DOT BW400.
- Puron refrigerant systems should be charged with liquid refrigerant. Use a commercial type metering device in the manifold hose when charging into suction line with compressor operating
- Manifold sets should be 700 psig high side and 180 psig low side with 550 psig low-side retard.
- Use hoses with 700 psig service pressure rating.
- Leak detectors should be designed to detect HFC refrigerant.
- Puron refrigerant, as with other HFCs, is only compatible with POE oils.
- Vacuum pumps will not remove moisture from oil.
- Do not use liquid-line filter driers with rated working pressures less than 600 psig.
- Do not leave Puron refrigerant suction line filter driers in line longer than 72 hours.
- Do not install a suction-line filter drier in liquid line.
- POE oils absorb moisture rapidly. Do not expose oil to atmosphere.
- POE oils may cause damage to certain plastics and roofing materials.
- Wrap all filter driers and service valves with wet cloth when brazing.
- A factory approved liquid-line filter drier is required on every unit.
- Do NOT use an R-22 TXV.
- If indoor unit is equipped with a R-22 TXV or piston metering device, it must be changed to a hard-shutoff Puron refrigerant TXV.
- Never open system to atmosphere while it is under a vacuum.
- When system must be opened for service, recover refrigerant, evacuate then break vacuum with dry nitrogen and replace filter driers. Evacuate to 500 microns prior to recharging.
- Do not vent Puron refrigerant into the atmosphere.
- Do not use capillary tube coils.
- Observe all **warnings, cautions, and bold** text.
- All indoor coils must be installed with a hard-shutoff Puron refrigerant TXV metering device.

