

This Owner's Manual is provided and hosted by [Appliance Factory Parts](#).



# LG LAN180HSV2 Owner's Manual

[Shop genuine replacement parts for LG LAN180HSV2](#)



[Find Your LG Air Conditioner Parts - Select From 2330 Models](#)

----- Manual continues below part list -----

## Available Replacement Parts for LG LAN180HSV2

<a href="#">4280A20004M</a>	Bearing
<a href="#">6871A20259D</a>	Sub Pcb Assembly
<a href="#">4681A20042E</a>	Motor Assembly,dc,stepping
<a href="#">EBG61107008</a>	Ntc Thermistor Assembly
<a href="#">ADQ68719501</a>	Air Cleaner Filter Assembly
<a href="#">EBG60787304</a>	Thermistor Assembly
<a href="#">EAU62004010</a>	Motor Assembly,dc,indoor
<a href="#">ADL72918701</a>	First Evaporator Assembly
<a href="#">ADP67778501</a>	Cross Flow Fan Assembly
<a href="#">MDJ61848401</a>	Deodorizing Filter
<a href="#">EBG61110706</a>	Ntc Thermistor Assembly
<a href="#">EBR35936513</a>	Main Pcb Assembly
<a href="#">MFH62063701</a>	Horizontal Louver
<a href="#">AKB74375403</a>	Remote Control



Internal Use Only

<http://biz.lgservice.com>

# Room Air Conditioner

## **SVC MANUAL(Exploded View)**

**MODEL : AS-W183CRM9(LAN180HSV2/LAU180HSV2)  
AS-W243CRM9(LAN240HSV2/LAU240HSV2)  
AS-W183C2Y9(LSN181HSV2/LSU181HSV2)**

### **CAUTION**

Before Servicing the unit, read the safety precautions in General SVC manual.  
Only for authorized service personnel.

# Product Specifications

Models		Unit	AS-W183CRM9	AS-W243CRM9	AS-W183C2Y9	
Cooling Capacity		kW	0.90~5.33~8.65	0.90 ~ 6.45 ~ 8.80	0.90~5.33~8.65	
		Btu/h.	3,070~18,200~29,515	3,070~22,000~30,030	3,070~18,200~29,515	
Heating Capacity		kW	0.90~6.45~11.40	0.90 ~ 8.09 ~ 11.40	0.90~6.45~11.40	
		Btu/h.	3,070~22,000~38,898	3,070~27,600~38,898	3,070~22,000~38,898	
Power Input	Cooling/Heating	W	1,447 / 1,760	2,040 / 2,670	1,447 / 1,760	
Running Current	Cooling/Heating	A	6.3/8.2	7.9 / 10.7	6.3/8.2	
Starting Current	Cooling/Heating	A	6.3/8.2	7.9 / 10.7	6.3/8.2	
EER		W/W	3.69	3.16	3.69	
		Btu/h.W	12.6	10.8	12.6	
SEER			20.5	20	20.5	
HSPF			9.7	10	9.7	
Power Supply		Ø / V / Hz	1/208-230/60	1/208-230/60	1/208-230/60	
Power Factor		%	98.2	98.2	98.2	
Air Flow Rate	Indoor,Max	m <sup>3</sup> /min(CFM)	20.8(735)	20.8(735)	20.8(735)	
	Outdoor,Max	m <sup>3</sup> /min(CFM)	60(2,119)	60(2,119)	60(2,119)	
Moisture Removal		l/h.	2.6	2.6	2.6	
Sound Level	Indoor,H/M/L	dB(A)±3	45/40/35	45/40/35	45/40/35	
	Outdoor,Max	dB(A)±3	53	53	53	
Refrigerant & Charge (at 7.5 m)		g(oz)	R410A, 1,800(63.5)	R410A, 1,800(63.5)	R410A, 1,800(63.5)	
Additional Refrigerant charge		g/m(oz/ft)	35(0.38)	35(0.38)	35(0.38)	
Compressor	Type		Twin Rotary	Twin Rotary	Twin Rotary	
	Model		GJT240DAA	GJT240DAA	GJT240DAA	
	Motor Type		Brushless DC Motor	Brushless DC Motor	Brushless DC Motor	
	Oil Type		PVE(FVD68C)	PVE(FVD68C)	PVE(FVD68C)	
	Oil Charge	cc	900	900	900	
	O.L.P. name		-	-	-	
Fan(Indoor)	Type		Cross Flow Fan	Cross Flow Fan	Cross Flow Fan	
	Motor Output	W	76.1	76.1	76.1	
Fan(Outdoor)	Type		Propeller	Propeller	Propeller	
	Motor Type		BLDC	BLDC	BLDC	
	Motor Output	W	124	124	124	
Circuit Breaker*		A	25	25	25	
Power Supply Cable		No.*mm <sup>2</sup>	3*2.5	3*2.5	3*2.5	
Power and Transmission Cable No.*mm <sup>2</sup>		No.*mm <sup>2</sup>	4*0.75 (Including Earth)	4*0.75 (Including Earth)	4*1.0 (Including Earth)	
Piping Connections	Liquid Side	mm(in)	9.52(3/8)	9.52(3/8)	9.52(3/8)	
	Gas Side	mm(in)	15.88(5/8)	15.88(5/8)	15.88(5/8)	
Drain Hose(O.D / I.D.)		mm(in)	21.5 / 16.0 (0.85 / 0.63)	21.5 / 16.0 (0.85 / 0.63)	21.5 / 16.0 (0.85 / 0.63)	
Dimensions	Indoor (W*H*D)	mm	1,030*325*245	1,030*325*245	1,030*325*245	
		inch	40.6*12.8*9.64	40.6*12.8*9.64	40.6*12.8*9.64	
	Outdoor (W*H*D)	mm	870*800*320	870*800*320	870*800*320	
		inch	34.3*31.5*12.6	34.3*31.5*12.6	34.3*31.5*12.6	
Net Weight	Indoor	kg(lbs)	17(37.5)	17(37.5)	14(30.86)	
	Outdoor	kg(lbs)	60(132.3)	60(132.3)	60(132.3)	
Operation Range	Cooling(Outdoor)	°C	-10~48(14.0~118.4)	-10~48(14.0~118.4)	-10(-18)*~48(14.0(0))*~118.4)	
	Heating(Outdoor)	°C	-10~24(5~75.2)	-10~24(5~75.2)	-10~24(5~75.2)	
Piping Length (Min/Max)		m(ft)	30(98.4)	30(98.4)	30(98.4)	
Chargeless		m(ft)	-	-	-	
Max. Elevation Difference		m(ft)	15(49.2)	15(49.2)	15(49.2)	
Tool Code(Chassis)	Indoor + Outdoor		SC_A + UE1Plus	SC_A + UE1Plus	SC + UE1Plus	
Functions	Temperature Control		O	O	O	
	Plasma Filter		O	O	O	
	Prefilter(washable/anti-fungus)		O	O	O	
	Auto Clean		O	O	O	
	Auto Swing		O	O	O	
	Steps, Fan/Cool/Heat		5/6/6	5/6/6	5/6/6	
	Airflow Direction Control(up&down)		Auto	Auto	Auto	
	Airflow Direction Control(left&right)		Auto	Auto	Auto	
	Remote Controller Type		Standard Wired Remocon, Wireless LCD(Better)			
	Setting Temperature Range	Cooling		18°C~30°C	18°C~30°C	18°C~30°C
		Heating		16°C~30°C	16°C~30°C	16°C~30°C
	Auto Operation (Micom Control)		O	O	O	
	Auto Changeover (Micom Control)		O	O	O	
	Self Diagnosis		O	O	O	
	Timer		24h On/Off	24h On/Off	24h On/Off	
	Sleep Operation		O	O	O	
	Soft Dry Operation		O	O	O	
	Restart Delay(minute)		3	3	3	
	Device Control(Defrost)		O	O	O	
	Hot Start		O	O	O	
	Jet Cool, Jet Heat		O	O	O	
	Low Ambient Operation		O	O	O	
	Special Function		WATER LEVEL SENSOR(OPTIONAL)			
	Network Functions	Dry Contact		O	O	O
		Network Solution(LGAP)		O	O	O
		PI485		O	O	O

**Note:**

O : Applied, - : No relation

\* Some of functions are slightly different depending upon models.

\* For circuit breaker rating, please conform to local standards wherever necessary.

\* The specification may be subject to change without notice for purpose of improvement.

★ With wind baffle accessory installed.Without wind baffle installed, the minimum temperature will be 14°F D.B.

## 2. Piping Diagrams

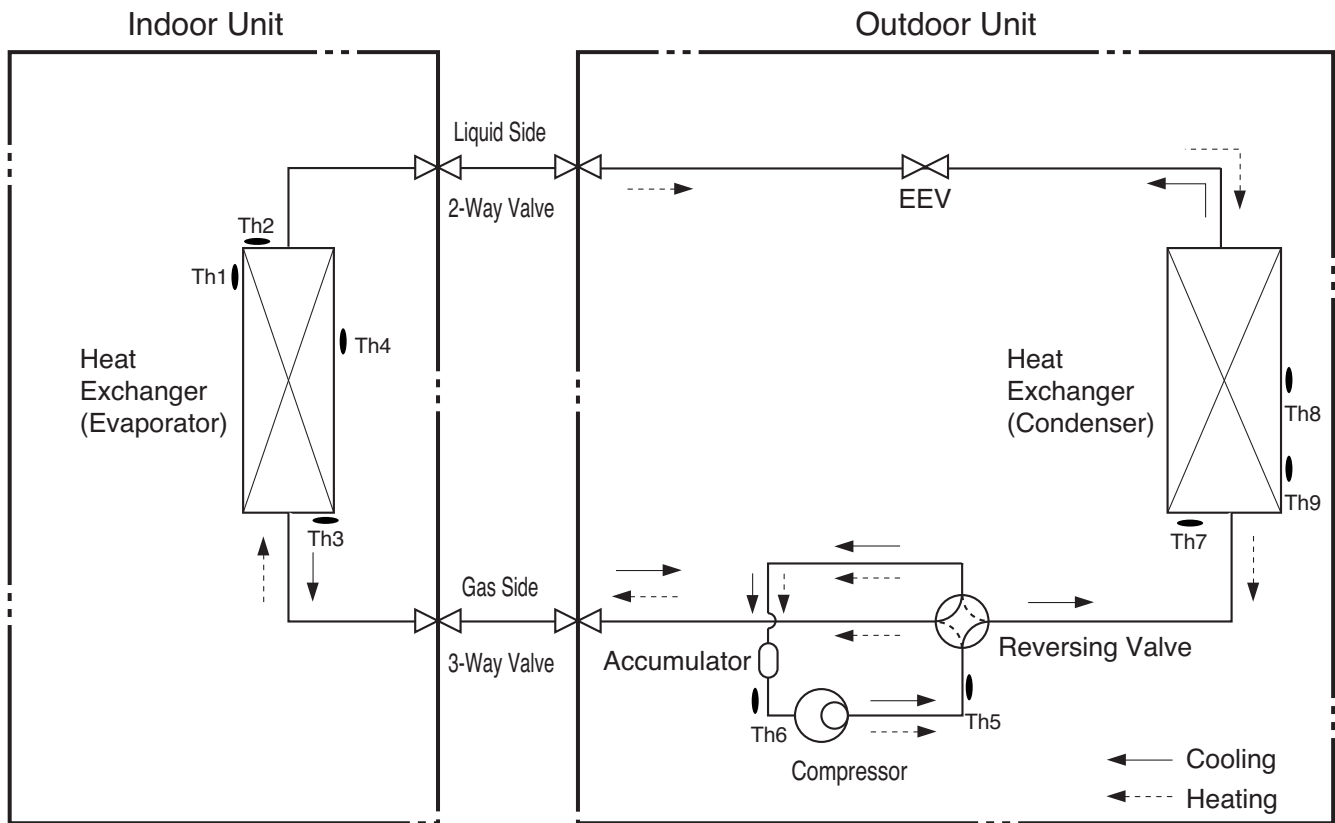

LOC.	Description	PCB Connector
Th1	Thermistor for suction air temperature	CN-TH1(Indoor)
Th2	Thermistor for evaporator inlet temperature	
Th3	Thermistor for evaporator outlet temperature + Water level sensor	
Th4	Thermistor for evaporator middle temperature	CN-TH3(Indoor)
Th5	Thermistor for discharge pipe temperature	CN-TH3(OUTDOOR)
Th6	Thermistor for suction pipe temperature	
Th7	Thermistor for condensing temperature	CN-TH2(OUTDOOR)
Th8	Thermistor for outdoor air temperature	
Th9	Thermistor for condensing middle temperature	CN-TH4(OUTDOOR)

※ EEV : Electronic Expansion Valve

# 3. Wiring Diagrams

## Indoor Unit

• MODEL : ASNW183CRM9, ASNW243CRM9

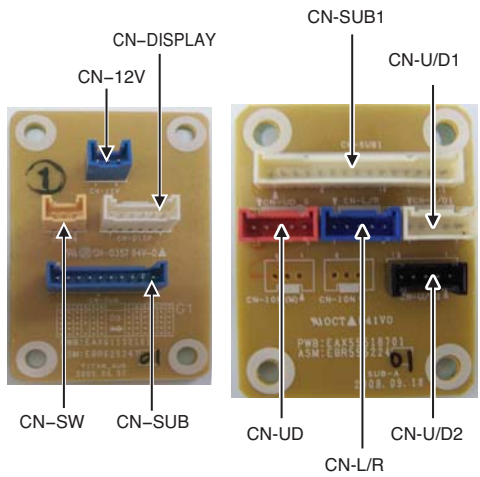
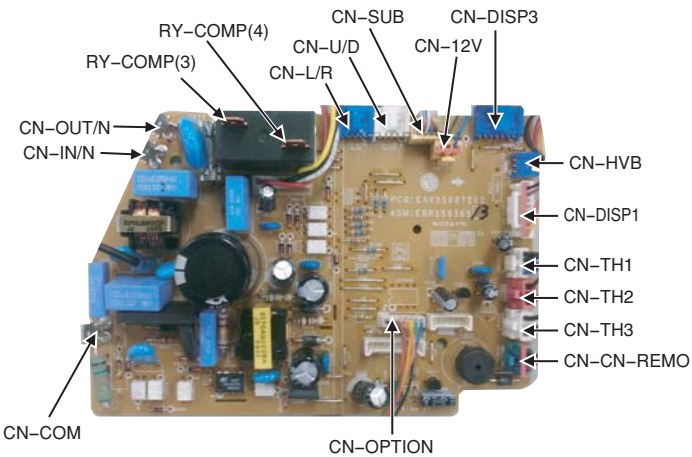
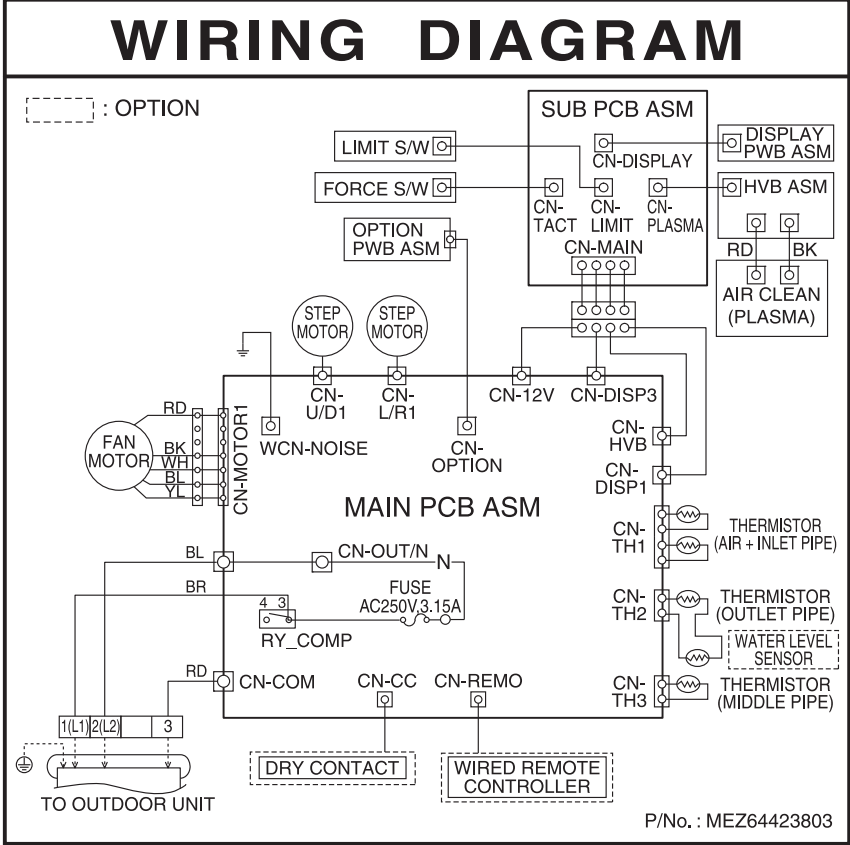

**Indoor Unit :**

**• MODEL : ASNW183C2Y9**

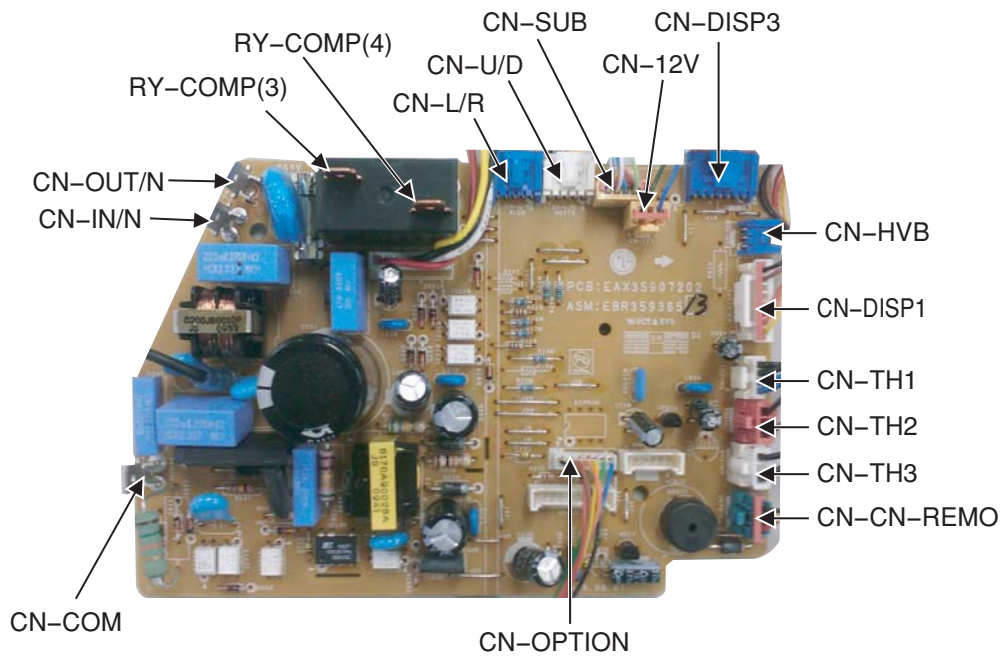
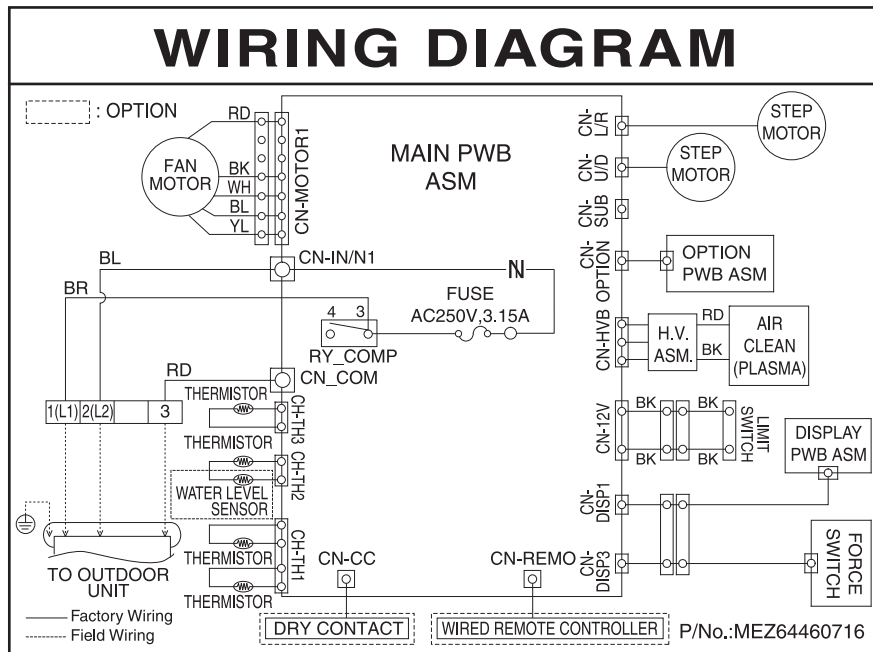

# Outdoor Unit

• Model : ASUW183CRM9, ASUW243CRM9, ASUW183C2Y9

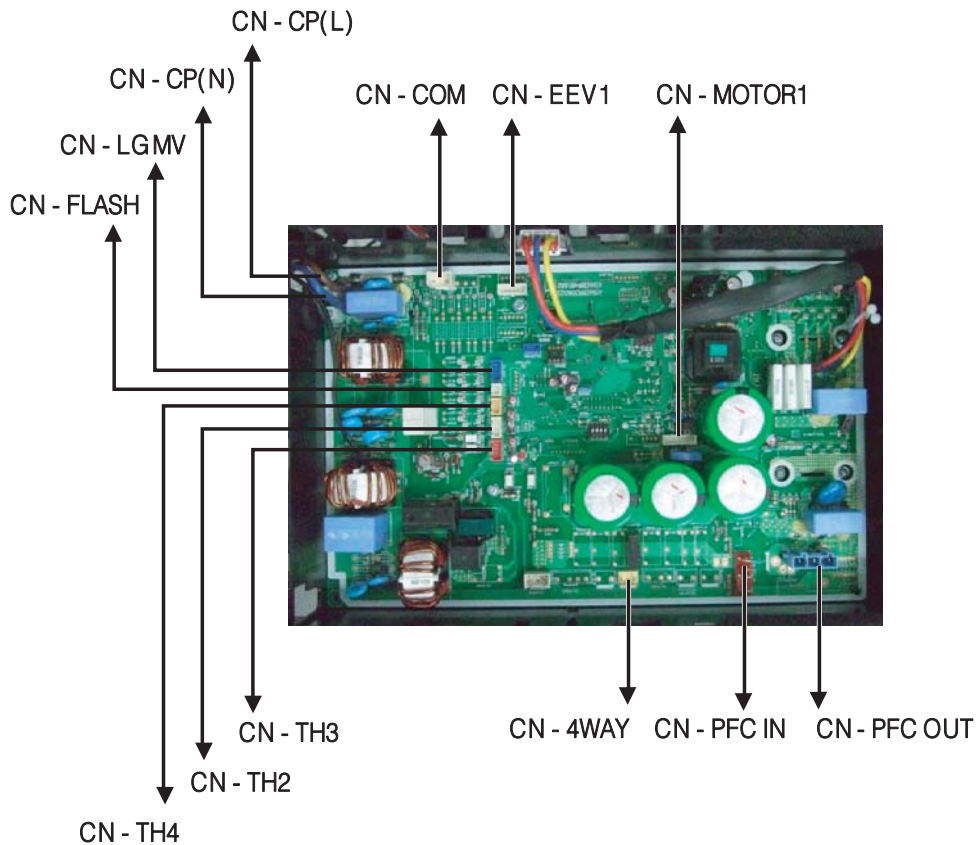
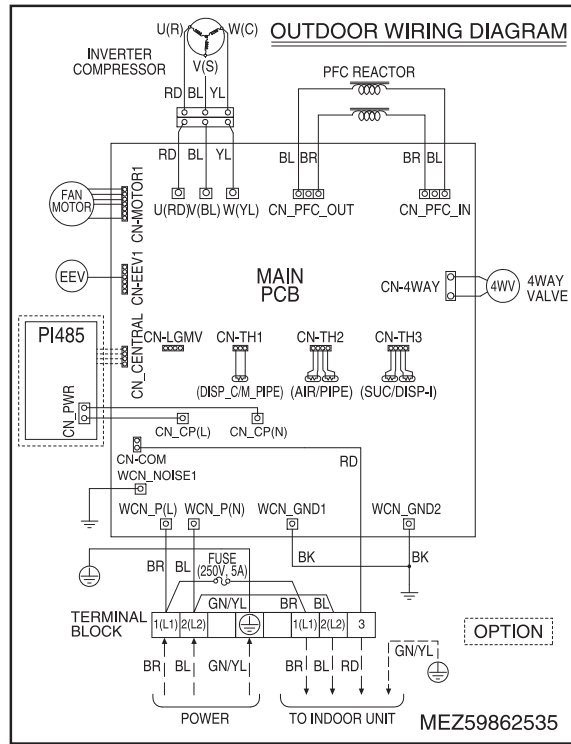

# Exploded View

## Indoor Unit

• Model : ASNW183CRM9, ASNW243CRM9

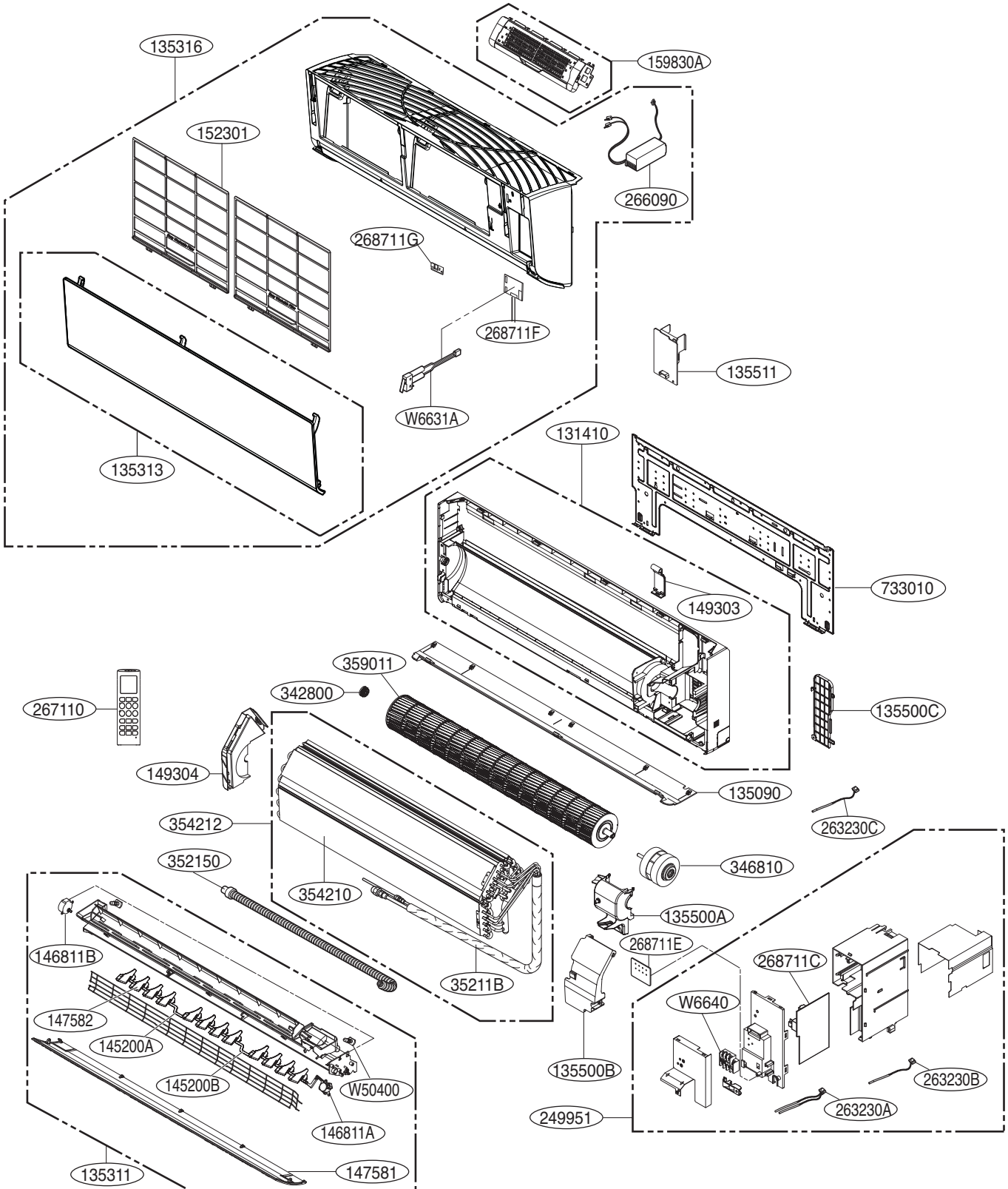

# Indoor Unit :

• Model : ASNW183C2Y9

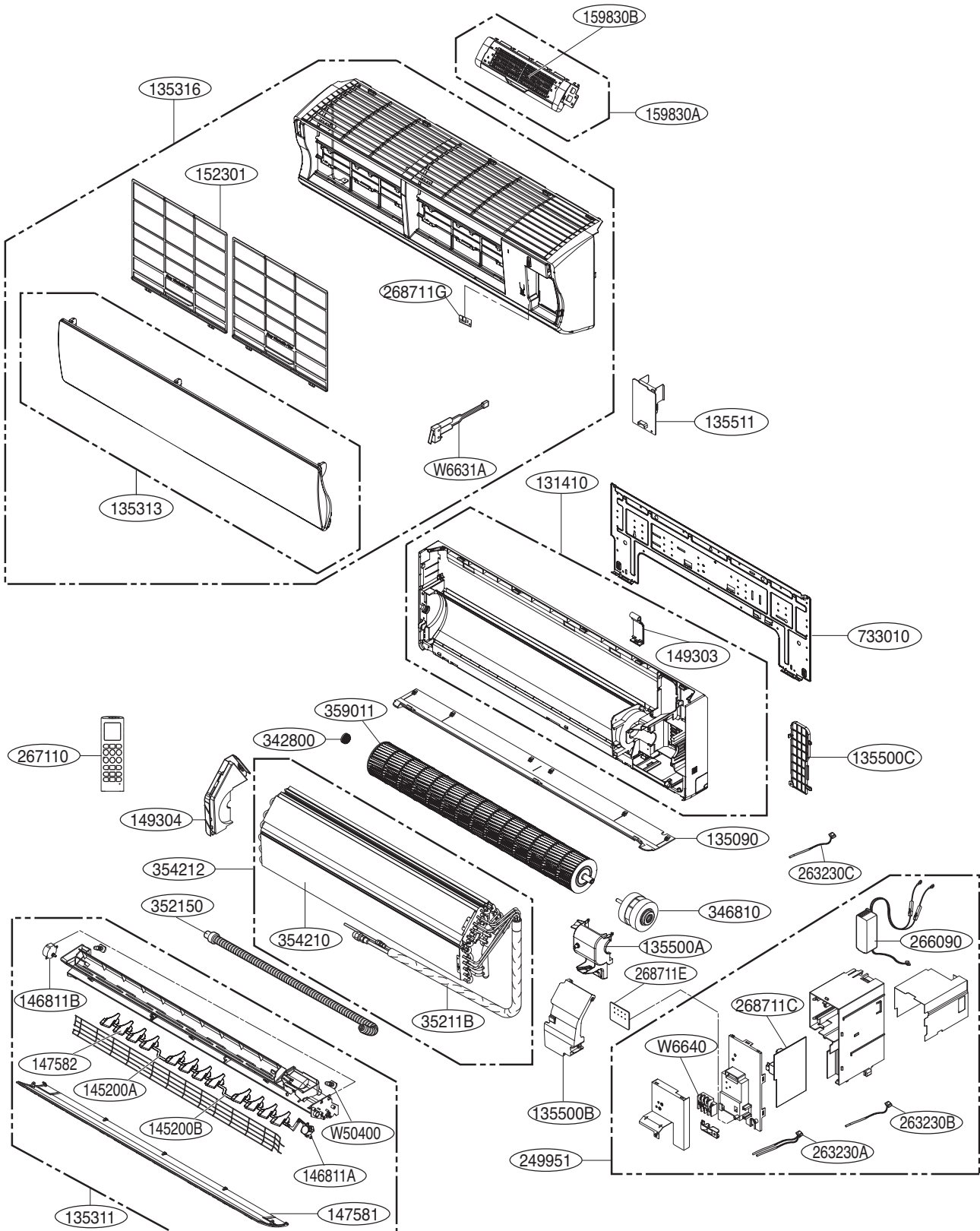

# Outdoor Unit

• Model : ASUW183CRM9, ASUW243CRM9, ASUW183C2Y9

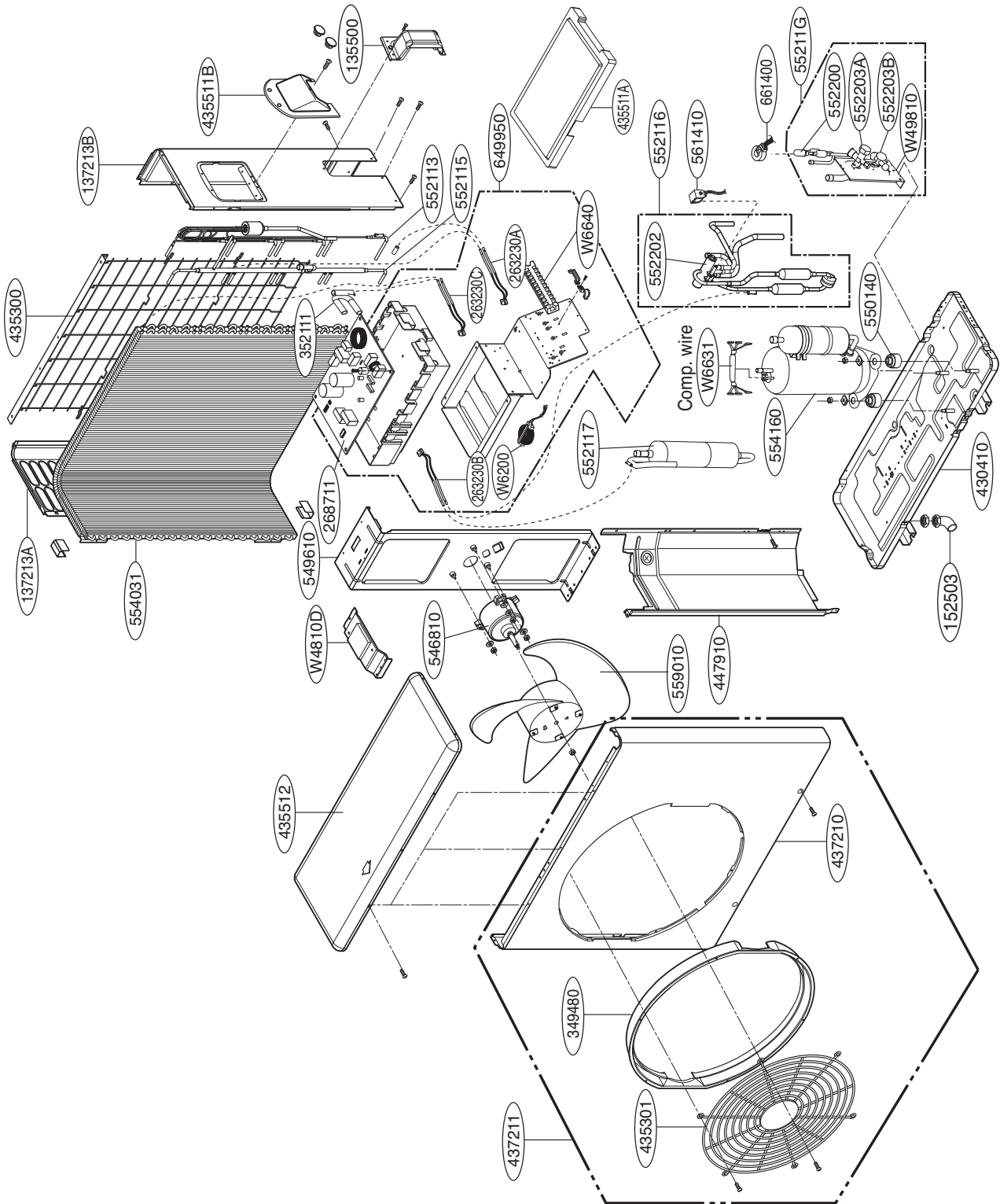



US	1. Please call the installing contractor of your product, as warranty service will be provided by them. 2. If you have service issues that have not been addressed by the contractor, please call 1-888-865-3026.
CANADA	Service call Number # : (888) LG Canada, (888) 542-2623

P/NO : MFL67501903

MAY, 2013