

TRION[®]

Air Purification Systems



READ AND SAVE THESE INSTRUCTIONS

Comfort*BREEZE*[™]
CB300/CB300S

Flow-Through Evaporative Humidifier

READ AND SAVE THESE INSTRUCTIONS
LIRE ET CONSERVER CES INSTRUCTIONS

TABLE OF CONTENTS

1. Warranty Statement 3

2. Safety Warnings 3

3. Introduction 4

 3.1 Basic Operation 4

 3.2 Specifications Table 4

 3.3 What's in the Box 4

4. Installation 4

 4.1 Clearances 4

 4.2 Mounting 4

 4.3 Plumbing 6

 4.4 Electrical/Wiring 7

 4.4.1 Wiring CB300 (without water saving controls) 7

 4.4.2 Wiring CB300S (with ComfortSmart Technology) 7

5. Operation 7

 5.1 Preliminary Checkout 7

 5.2 Starting and Stopping the humidifier 7

 5.3 End Of Season Decommissioning 8

6. Maintenance/Troubleshooting 8

 6.1 Pad Replacement 8

 6.2 Control Board Faults & Reset 8

 6.3 Troubleshooting Chart 9

 6.4 Exploded View/Parts List 10

1. Warranty

Humidifier 5-Year Limited Warranty

This limited warranty covers Trion Residential Type Humidifiers, excluding duct work, wiring and installation. Trion warrants that all new Trion humidifiers are free from defects in material and workmanship under normal, non-commercial use and service. Trion will remedy any covered defects if they appear within 60 months from the date of original installation & subject to the terms and conditions of this Limited 5-Year Warranty stated below:

1. THIS LIMITED 5-YEAR WARRANTY is granted by Trion Customer Service, 101 McNeill Road, Sanford, NC 27330.
2. This warranty shall extend only to any non-commercial owner who has purchased the residential humidifier other than for purposes of resale.
3. All components are covered by this limited warranty except expendable items, such as evaporative pads, media filter pads and nozzles.
4. If, within the warranty period, any Trion residential humidifier unit or component requires service it must be performed by a competent heating and/or air conditioning contractor (preferably the installing contractor). Trion will not pay shipping charges, or labor charges to remove or replace such defective parts or components. If the part or component is found by inspection to contain such defective material and workmanship it will be either repaired or exchanged free of charge at Trion's option, and returned freight collect.
5. In order to obtain the benefits of this limited 5-year warranty, the owner must notify the dealer or distributor of any defect within 30 days of its discovery. If after reasonable time you have not received an adequate response from the dealer or distributor, notify in writing to Trion Customer Service 101 McNeill Road, Sanford, NC 27330, or call 1-800-884-0002 or email customerservice@trioniaq.com Humidifiers which have been installed or become part of real estate cannot be returned. Trion will receive, freight prepaid, only removable parts or components of such defective humidifiers.
6. This limited warranty does not apply to any part or component that is damaged in transit or in handling, has been subject to misuse, neglect or accident; has not been installed, operated and serviced according to Trion's instructions; has been operated beyond the factory rated capacity; or altered in any such way that its performance is affected. There is no warranty due to neglect, alteration or ordinary wear and tear. Trion's liability is limited to replacement of defective parts or components and does not include the payment of the cost of labor charges to remove or replace such defective components or parts.
7. Trion will not be responsible for loss of use of any product; loss of time, inconvenience, or any other indirect, incidental or consequential damages with respect to person or property, whether as a result of breach of warranty, neglect or otherwise. SOME STATES DO NOT ALLOW THE EXCLUSION OR LIMITATION OF INCIDENTAL OR CONSEQUENTIAL DAMAGES, SO THE LIMITATION OR EXCLUSION IN THE PRECEDING SENTENCE MAY NOT APPLY TO YOU.
8. THIS WARRANTY GIVES YOU SPECIFIC RIGHTS, AND YOU MAY ALSO HAVE OTHER RIGHTS WHICH VARY FROM STATE TO STATE.
9. Any warranty by Trion of merchantability, fitness for use or any other warranty (express, implied or statutory), representation or guarantee other than those set forth herein, shall expire at the expiration date of this express limited warranty. SOME STATES DO NOT ALLOW LIMITATIONS ON HOW LONG AN IMPLIED WARRANTY LASTS, SO THE LIMITATION IN THE PRECEDING SENTENCE MAY NOT APPLY TO YOU.
10. Trion reserves the right to make changes in the design and material of its products without incurring any obligation to incorporate such changes in units completed on the effective date of such change.

2. Safety & Warnings

DANGER

RISK OF ELECTRIC SHOCK

Before cleaning, servicing, or parts replacement, the unit must be disconnected from all sources of electricity.

WARNING

Improper installation, adjustment, alteration, service, or maintenance may cause property damage, injury, or death. This appliance must be installed according to these instructions. Read these instructions thoroughly before installing or servicing the unit.

CAUTION

Read these instructions thoroughly before installing this unit. Check data label and verify electrical specifications agree with those at the point of installation.

WARNING

Failure to install this unit in a position that is level and plumb may impair the unit's ability to drain if an overflow condition presents itself. Damage to personal property may also result.

WARNING

Installation in freezing conditions can result in unit failure. Damage to personal property may also result.

WARNING

A drain pan should be installed under the unit and any supply water / drain connections to prevent damage to property in the event of a water leak or faulty operation.

CAUTION

Trion recommends that this humidifier be installed by a trained HVAC professional. Do not connect the unit to the power source until the installation is complete. A thorough checkout of the unit installation should be completed before operating the unit. Failure to follow these directions may void the manufacturer's original warranty.

WARNING

Electrical power to the furnace must be disconnected before proceeding. Serious injury or death may result.

3. Introduction

The benefits of a properly humidified environment (35-50% Relative Humidity) are many. They include both personal comfort as well as the preservation of furniture, draperies, carpets, wooden floors and cabinets, paintings, pianos, etc. Your home can be more comfortable at a lower temperature (i.e.: 68° F) at 30-40% Relative Humidity (RH) than at 71° to 72° F without controlled humidity. Since every degree of temperature setback represents about 3% of your heating costs, this can possibly represent a significant annual savings. During the heating season, cold air infiltrates the home and must be heated. When heated, this air dries out and greatly increases its capacity to hold more moisture. By using a humidifier, a source of water is provided to satisfy this increased moisture holding capability, rather than having it drawn from our body surface and the surrounding furnishings in the home.

3.1 Basic Operation

Your ComfortBREEZE™ flow-through evaporative humidifier operates on the principles of evaporation. Water is introduced to an evaporator pad as warm air from the duct is circulated through the pad. The warm air evaporates the water and the relative humidity of the air increases. Any excess water is passed to the drain. CB300S units are equipped with a ComfortSmart controller which acts to minimize the amount of water that may flow to the drain by adjusting the total water flow to the humidifier.

Setting the humidistat in the recommended range of 30-40% relative humidity assures automatic humidity control during the heating season. A lower setting may be necessary to prevent condensation on windows during the coldest part of the winter. An electronic humidistat is supplied with CB300S units that can automatically adjust the setpoint as the outdoor temperature falls.

Minimal action is needed to turn the humidifier off for the summer months. Simply rotate the damper to the closed position and lower the humidistat setpoint.

3.2 "What's In The Box?"

CB300	CB300S	Description
X	X	Humidifier
X		Mech. Humidistat (CB300)
	X	Electronic Humidistat (CB300S)
X		Transformer (CB300 only)
X	X	Parts Bag

3.3 Unit Specifications

Type of Unit	Bypass Evaporative
Mounting	Warm Air Supply/Return Duct
Capacity (GPD)	22.0 GPD @ 140 °F 17.0 GPD @ 120 °F 14.5 GPD @ 100 °F
Water Supply	20-100 PSI

Voltage(Amps)	24 VAC(0.8A)
Unit Dimensions	14.13"W x 10"D x 19"H
Water Supply Connection	1/4" OD Tubing
Drain Water Connection	1/2" ID Tubing
Duct Opening	9.75"W x 13.13"H
Shipping Weight	11.25 Lbs.
Operating Weight	8.5 Lbs.
Approvals	ETL

4. Installation

Prior to installing this product:

- Read the instructions carefully and completely to ensure safe operation. Failure to follow the instructions could lead to damage to the product or cause a hazardous condition.
- Check the ratings given on the product to make sure it is suitable for your application.

Remember to select a location that is readily accessible for periodic inspection, cleaning, and service. The following table on page 5 indicates the minimum allowable installation clearances. The following illustrations show some of the possible installation configurations and where the humidifier should be installed. This humidifier may be installed on the supply or return side of the furnace. Operation with the warmest possible air will maximize output capacity. Installation on the supply duct after the furnace discharge is recommended.

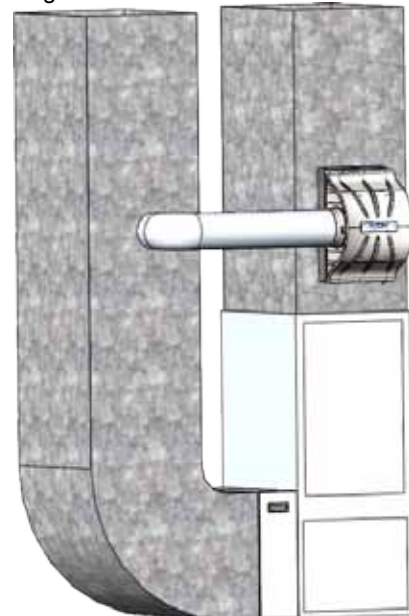

Upflow - Side Return

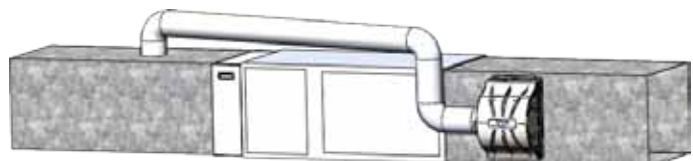

Horizontal Flow

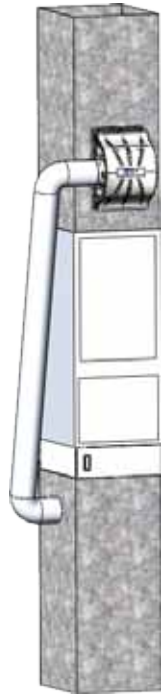

Upflow - Bottom Return

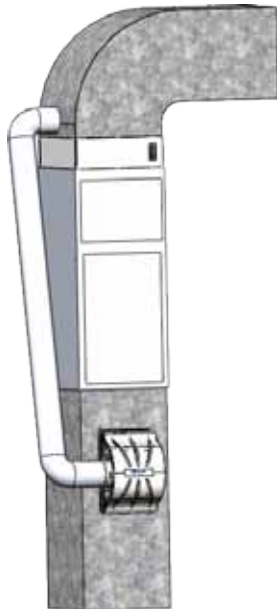

Down-flow

4.1 Recommended Minimum Installation Clearance

Left	3 inches
Right	3 inches
Top	2 inches
Bottom	6 inches
Back	12 inches

Side Clearance (Left or Right) must be sufficient to accommodate the by-pass duct connection. Evaluate installation location as needed to ensure there is space available.

⚠ CAUTION

Trion recommends that this humidifier be installed by a trained HVAC professional. Do not connect the unit to the power source until the installation is complete. A thorough checkout of the unit installation should be completed before operating the unit. Failure to follow these directions may void the manufacturer's original warranty.

4.2 Mounting

The ComfortBREEZE CB300/CB300S humidifier may be mounted directly to the warm air supply duct or the return duct of your HVAC system. Certain conditions must be met to ensure proper unit operation. Refer to the following list.

- Ensure that the duct surface is reinforced, if necessary, to allow the unit to remain level and plumb.
- Ensure that the humidifier has adequate clearance to allow for the removal and replacement of the evaporator pad.
- When installing the humidifier in an attic or above a ceiling, a drain tray must be installed under the unit as a precautionary measure to prevent water damage from occurring if a leak develops.
- The recommended humidistat range is 30-40% relative humidity. If condensation occurs on windows, the humidistat setting must be lowered to prevent condensation damage.
- DO NOT install the humidifier where freezing temperatures may occur.
- DO NOT install the humidifier where it interferes with the furnace access panels.
- DO NOT install the humidifier close to a flue pipe. Intense heat may damage the humidifier.
- DO NOT mount the humidifier in the jacket of a cased coil. It is preferable to mount the humidifier immediately downstream of the cased coil, if present. Ensure that the humidifier does not interfere with the coil ends.
- DO NOT mount the humidifier in a furnace jacket.
- DO NOT install on gravity hot air systems.
- DO NOT connect a hot water supply to ComfortBreeze humidifiers that are equipped with water saving controls. (ComfortSmart Technology).

1. Tape the mounting template to the duct so that it is flat and the top edge is level.
2. Carefully remove the center of the template by tearing along the perforated lines. Use a marker to trace on the duct along the cutout opening.

⚠ WARNING

Electrical power to the furnace must be disconnected before proceeding. Serious injury or death may result.

3. Drill the holes marked on the template. Remove the template from the duct and carefully cut the duct along the outside edge of the rectangle that was traced by the marker. Remove any burrs from the cut edge of the sheet metal taking care not to injure yourself.
4. Apply the gasket material found in the accessory bag to the duct around the rectangular cutout.
5. Lift the humidifier into the rectangular opening so that the plastic tabs engage the lower edge of the rectangular opening. The tabs should be on the inside of the duct. Tilt the upper edge of the humidifier against the duct so that the mounting holes line up with the drilled holes on the duct. Secure the humidifier with two #8 X 3/4" self-drilling-

6. Refer to the section regarding pad replacement on page 8. Complete that section before proceeding to ensure that the internal components of the humidifier are properly aligned/installed as they may have become misaligned during shipment. **Failure to complete this task may result in faulty operation or leaks.**
7. Ensure that the humidifier is level and plumb before proceeding.

4.3 Plumbing

1. Install a saddle valve and strainer (not provided) on the nearest **cold** water supply pipe. **Hot water will cause improper operation.** (See the instructions that accompany the saddle valve for additional details).
2. After the saddle valve and strainer are installed but before inserting the line into the humidifier supply fitting, turn the saddle valve to the open position and discharge the water into a bucket or pan. This will allow the water to flush any debris that may have accumulated in the line during the installation process. Once this is complete, close the saddle valve.
3. Attach the line to the humidifier by simply pushing the line into the push-to-lock fitting and pulling back slightly to seat the line. If it becomes necessary to remove the line, press on the release ring around where the line goes into the fitting to release the line and pull it out. See Figure 5 for plumbing diagram.
4. Connect the drain hose to the drain connection fitting and run this to an open, gravity drain. The end of this line must not be submerged in water or be trapped.
5. Turn on the saddle valve.
6. Ensure that no water is leaking from any of the fittings before proceeding.

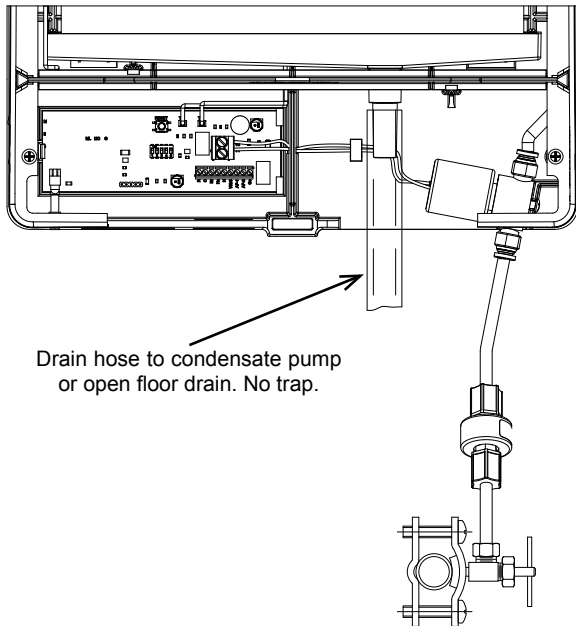

Figure 5

4.4 Electrical

The ComfortBreeze CB300/CB300S humidifier requires a 24 VAC source of electrical power that may be taken from the HVAC system terminals. In order to access the wiring compartment press the release pads, as shown in Figure 6, and pull the cover off toward you.

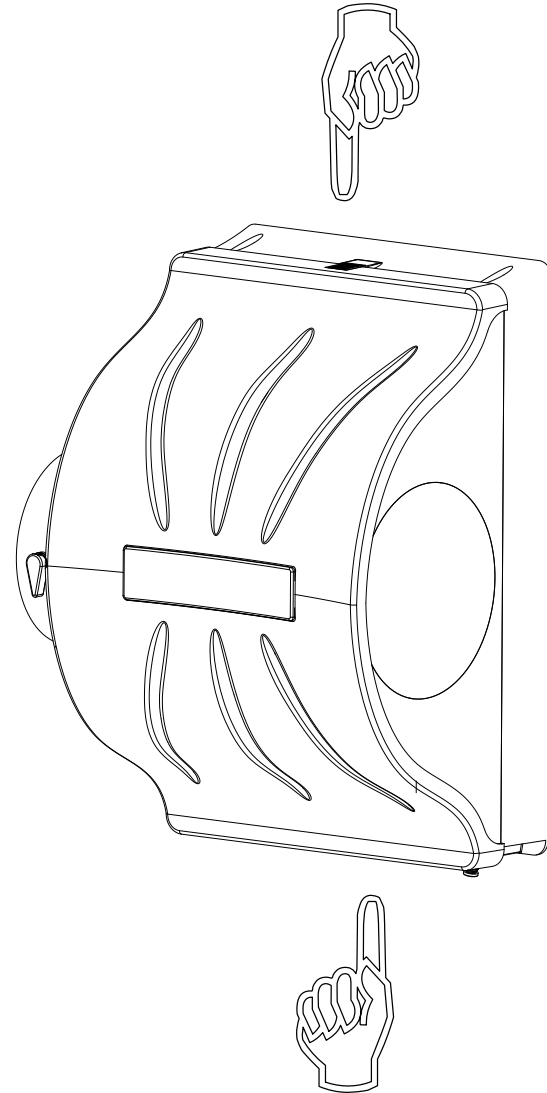

Figure 6

4.4.1 Wiring Model CB300 (without water saving controls)

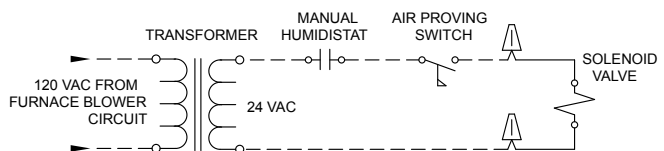

Figure 8

Refer to Figure 8. Install the 24 Volt transformer from a source of 120VAC power that is only powered when the furnace fan is energized. The transformer will supply 24 VAC through the humidistat and air proving switch (not included) and energize the water solenoid valve upon a call-for-humidity.

4.4.2 Wiring Model CB300S (ComfortSmart equipped model)

The CB300S is equipped with a circuit board that controls when the water valve is powered. Figure 9 shows the main parts of the board. Refer to Figure 10 for the wiring diagram. Refer to the wiring notes shown after Figure 10 for board wiring/control configurations that explain how to set the board based upon the type of system it is being installed on. These recommendations will provide the best performance and water savings depending on the type of furnace system.

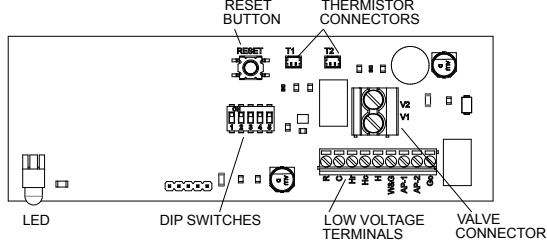

Figure 9

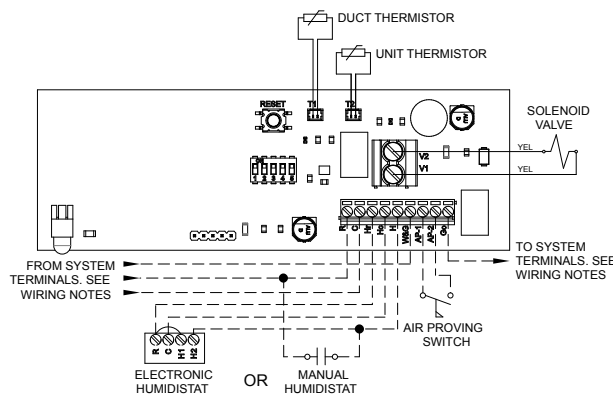

Figure 10

The source of 24 VAC comes from the HVAC system terminals. The typical terminal designators are used, such as R, C, G, W, etc. The following list identifies the low voltage terminals and their respective connection.

- R = 24 VAC from the HVAC system
- C= 24 VAC common from the HVAC system
- Hr = 24 VAC output for powering the electronic humidistat (if equipped)
- Hc = 24 VAC common for the electronic humidistat (if equipped)
- H = Humidistat input (must be 24 VAC)
- W/G = Input from HVAC system. This is used when the humidifier is used with warm air furnaces.
- AP1/AP2 = Air proving switch is connected here. Do not apply voltage.
- Go = 24 VAC output may be used to energize a relay or connected back to the thermostat "G" terminal to turn on the fan. Thermostat functionality may vary and affect the operation of this output.

DIP Switches/Settings:

- DIP #1 = Bypass or Motorized (Factory Set)
- DIP #2 = High Capacity/Low Capacity - This is factory set to High Capacity. If you determine that the humidifier is too large for the load, you may change the DIP switch

position to ON. It is not necessary in most cases.

- DIP #3 = Temperature Check - If you are installing this humidifier on a system that will have duct temperatures regularly below 100°F, set this DIP switch to the OFF position. Typical furnace bonnet temperature is nominally 120°F.
- DIP #4 = Furnace Runs Fan/Humidifier Runs Fan - In most systems the HVAC system operates the main blower. The CB300S has a 24VAC output that may be used to start the main blower if you would like to be able to get some humidification while the furnace is off.
- DIP #5 = Temperature Override - This DIP switch is factory set to OFF. In the event of a T1 thermistor failure, this switch may be set to ON. This will allow the humidifier to operate temporarily with a single thermistor until a replacement is aquired.

Wiring Notes (CB300S only):

When installing the CB300S on a furnace system, the humidifier may operate only when there is a call-for-heat OR the humidifier may be configured to start the HVAC blower whenever there is a call-for-humidity.

Single Stage Furnace: Humidifier operates upon call-for-humidity only during a call-for-heat.

- DIP Switch #3: On
- DIP Switch #4: Off
- Air Proving Switch: Recommended but not required. If no air proving switch is used, install a jumper across the AP1/AP2 terminals
- Go Terminal: No Connection
- W/G Terminal: Connected to System "W"

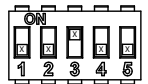

Multi Stage/Modulating Furnace: Humidifier operates upon call-for-humidity only during a call-for-heat.

- DIP Switch #3: Off
- DIP Switch #4: Off
- Air Proving Switch: Required
- Go Terminal: No Connection
- W/G Terminal: No Connection



Single or Multi Stage Furnace: Humidifier operates upon a call-for-humidity and will start the HVAC blower.

- DIP Switch #3: Off
- DIP Switch #4: On
- Air Proving Switch: Recommended but not required. If no air proving switch is used, install a jumper across the AP1/AP2 terminals
- Go Terminal: Connected to System "G"
- W/G Terminal: No Connection



Although the capacity of the humidifier may be reduced by more than 40%, the CB300S may be installed on a heat pump system and configured to operate only when there is a call-for-heat OR the humidifier may be configured to start the HVAC blower whenever there is a call-for-humidity.

Heat Pump System: Humidifier operates upon call-for-humidity only during a call-for-heat.

- DIP Switch #3: Off
- DIP Switch #4: Off
- Air Proving Switch: Required
- Go Terminal: No Connection
- W/G Terminal: No Connection

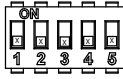

Heat Pump System: Humidifier operates upon a call-for-humidity and will start the HVAC blower.

- DIP Switch #3: Off
- DIP Switch #4: On
- Air Proving Switch: Recommended but not required.
If no air proving switch is used, install a jumper across the AP1/AP2 terminals
- Go Terminal: Connected to System "G"
- W/G Terminal: No Connection

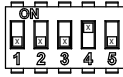

5. Operation

Once the CB300/CB300S is installed and ready to be started, the humidistat and DIP switches on the control board within the humidifier unit must be configured. The CB300 without the ComfortSmart controls does not have any DIP switches to configure. You may skip to the Preliminary Checkout and Start-up Sequence.

5.1 Preliminary Checkout and Start-up Sequence

1. Check that unit drain plumbing is properly connected and drained.
2. Ensure that the supply plumbing is installed properly.
3. Open cold water supply and insure water is reaching the unit. Incoming water line should be filtered.
4. With the unit powered, when the humidistat has a "call for humidity", the indicator LED will illuminate Green and the unit will begin operation.
5. If at any point the indicator LED illuminates red or blinks red/green alternating, a fault has been detected; service will be required and the fault must be reset. Refer to the Maintenance & Troubleshooting section.
6. Refer to the humidistat manual for "call for humidity" percentage settings.

5.2 Starting/Stopping the unit

In order to start and stop the unit you must only lower the humidistat setting to a point at which the contacts are open.

6. Maintenance & Troubleshooting

⚠ DANGER - RISK OF ELECTRIC SHOCK

Before cleaning, servicing, or parts replacement, the unit must be disconnected from all sources of electricity.

6.1 Pad Replacement

It will become necessary to replace the pad inside your ComfortBreeze CB300/CB300S humidifier as time goes on. A red LED Service indicator light may light up. This will tell you that it is time to service your humidifier. Please refer the following procedure.

1. Adjust Humidistat to the lowest setting to ensure that there is no call for humidity.
2. Ensure that power to the humidifier has been turned off so that the humidifier will not operate while service is being performed.
3. Close the water supply valve so that no water may flow to the humidifier during servicing.
4. To remove the humidifier cover, press the release pads as shown in Figure 11 and pull the cover toward you.
5. To remove the evaporator pad, push the retaining clips and pull the top pad retainer out from the base. The retainer and pad will come out together. The drain pan stays inside the unit. See Figure 12.
6. Reassemble the humidifier.
7. If required, reset the service timer (RED LED) by pressing the reset button on the circuit board (if equipped) for 3 seconds. CB300S units with ComfortSmart Technology include a circuit board.

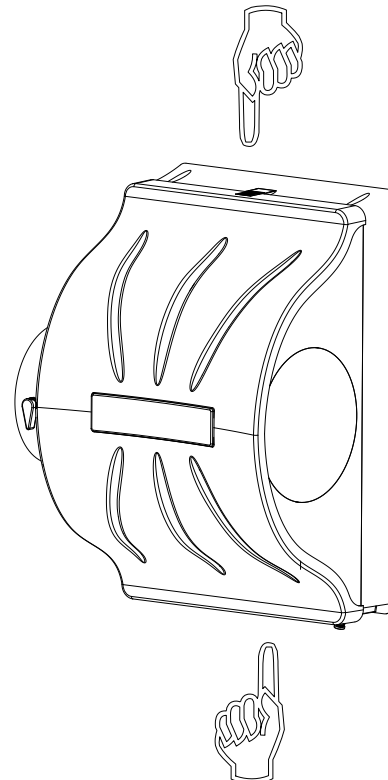

Figure 11

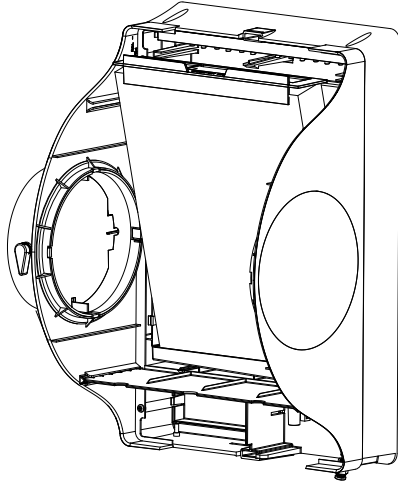

Figure 12

6.2 Control Board Faults & Reset

Faults are indicated by a red and green flashing LED located on the base of the unit in the lower left corner. There is a reset button on the control board that will reset the unit in the event of a fault. Pressing the reset button for 3 seconds will reset the controls and clear the faults. Use the fault list below and the troubleshooting chart to diagnose the fault and correct any issues that may be present.

When the LED is glowing solid green, the unit is humidifying and operating normally. The following list describes the faults that may occur and will be displayed by the LED's.

1. Rapid Red Blink = Terminals AP1 & AP2 for the air proving switch did not close. The unit will not operate until airflow is present.
2. Slow Red Blink = Once the solenoid valve is energized and humidification has begun, the controls must see a change in temperature or the unit will not be allowed to operate. This may be an indication of interrupted water supply.
3. Alternating Red/Green Blink = One of the thermistors has failed.
 - If T1 has failed the LED will blink Green/Red/Red with a two second delay. The unit will not operate in this condition unless DIP switch #5 is turned ON and the reset button is pressed.
 - If T2 has failed the LED will blink Green/Green/Red with a two second delay. The unit will not operate in this condition unless the T1 thermistor is relocated to act as T2 and DIP switch #5 is turned ON. Using the override DIP switch is only recommended as a temporary solution until the failed thermistor can be replaced.
4. Solid Red LED = This functions to remind the homeowner to replace the evaporator pad. The unit will continue to operate and the LED may be cleared by pressing the reset button on the control board.

6.3 Troubleshooting Chart CB300S (ComfortSmart) units only

Problem/Symptom	Probable Cause	Corrective Action
Power is applied and the LED does not illuminate.	No issue.	The LED does not illuminate unless the humidistat terminals are closed.
Humidistat contacts are closed but the unit will not operate.	System Calibration in progress.	Wait 2 minutes for the unit to begin operating.
	Solenoid Valve is not operating	Ensure that there is power supplied to the valve. Check control board output.
	Circuit Board has failed/fuse is blown	Replace circuit board.
LED is glowing solid RED.	Service Timer has expired	Replace the humidifier pad and reset the LED. See page 8.
LED displays a rapid red blink.	Air proving switch did not close allowing the unit to start. Unit will not operate if airflow is not present.	Ensure that the fan is operating and reset the control board by pressing the reset button for 3 seconds.
LED displays a slow red blink.	No temperature change measured by thermistors.	Ensure thermistors are connected.
		Check water supply.
		Verify that the evaporator pad is getting wet.
LED displays an alternating red/green blink pattern.	Thermistor failure.	See page 9.

Model CB300 w/o circuit board

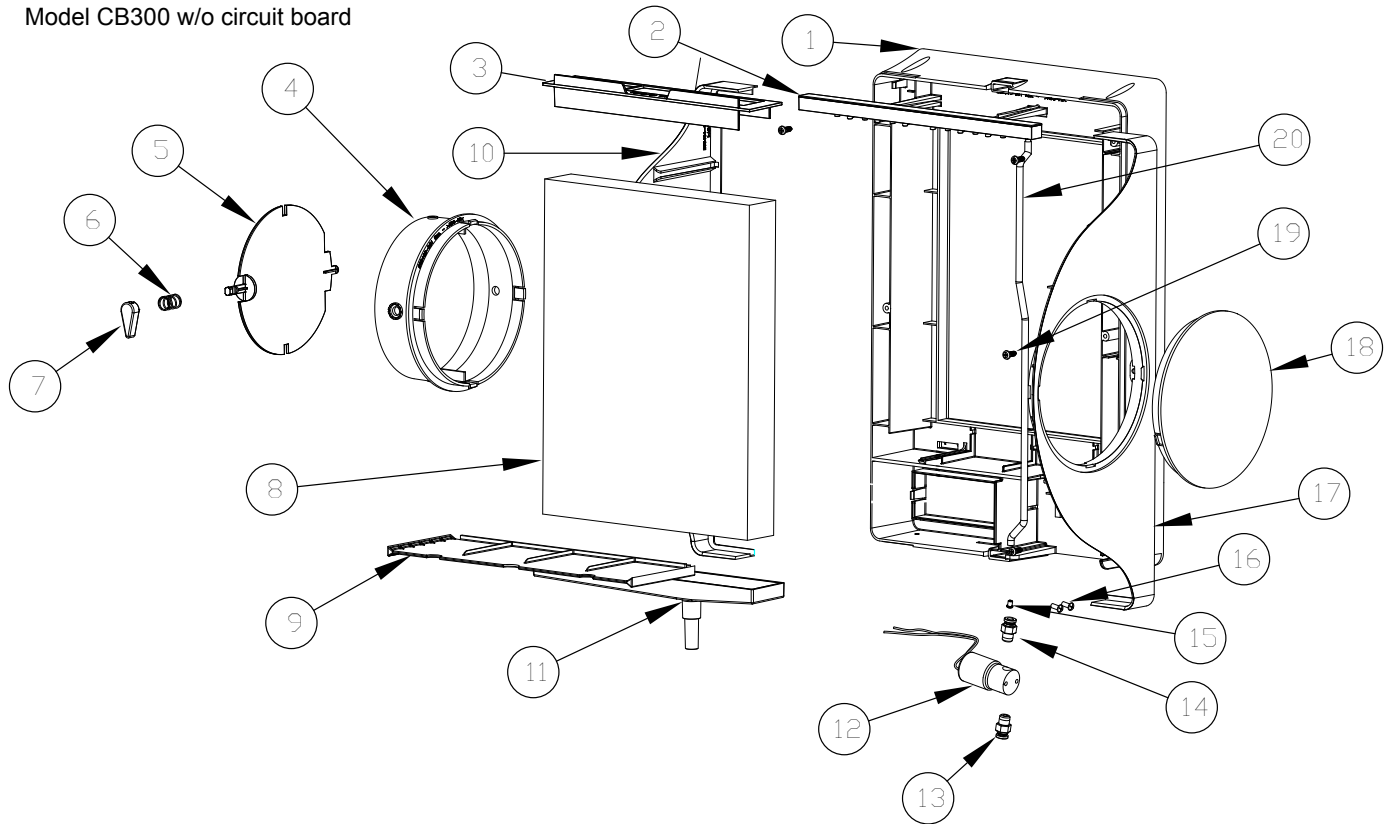

Model CB300S w/ ComfortSmart Controls

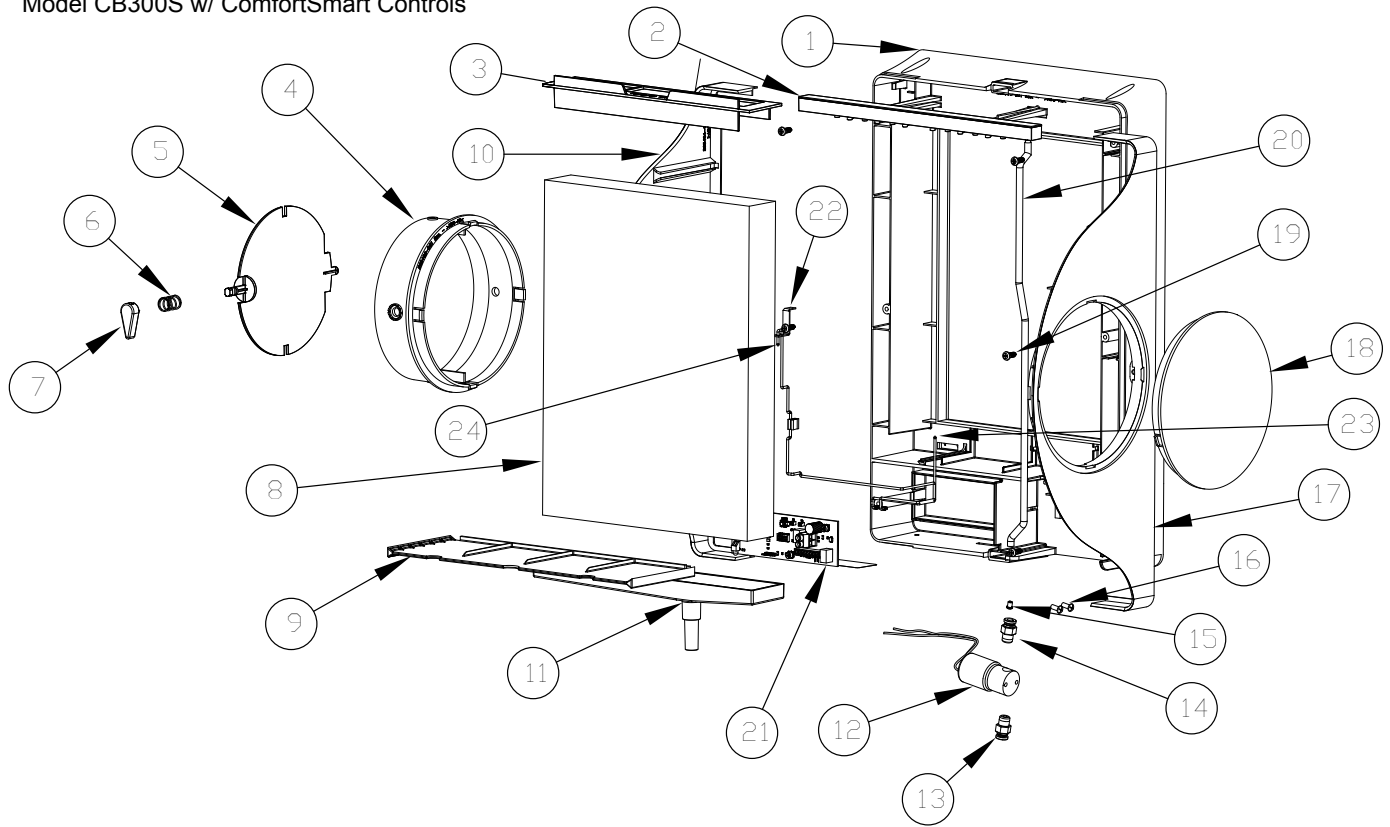

Installation, Operation, & Maintenance Manual

265686-002 / CB300 w/o circuit board	265686-001 / CB300S w/ ComfortSmart Controls	ITEM	TRION P/N	DESCRIPTION
1	1	1	265456-001	COMFORTBREEZE FILTER RETAINER
1	1	2	265455-001	COMFORTBREEZE DRAIN TRAY
2	2	3	265464-001	BY-PASS SIDE PANEL W/DUCT
1	1	4	465466-001	BY-PASS DIVIDER
1	1	5	265469-001	BY-PASS DOME
-	1	6	265457-001	ASS'Y-DISTRIBUTION TUBE 18 HOLE
1	-	6	265457-002	ASS'Y-DISTRIBUTION TUBE 6 HOLE
1	1	7	G-109	G-109 SOLENOID VALVE ASSEMBLY
-	1	8	265508-002	CONTROL BOARD, CB 300-S
2	2	11	265698-001	PNEUMATIC PUSH-TO-CONNECT FITTING
-	1	12	G-128	FLUID RESTRICTOR
1	-	12	G-217	FLUID RESTRICTOR
1	1	14	265470-001	PAD - EVAPORATOR
-	1	15	266180-001	THERMISTOR ASSEMBLY, APPROX. 9"
-	1	16	266180-002	THERMISTOR ASSEMBLY, APPROX. 19.5"
-	1	17	266158-001	CABLE CLIP
1	1	18	465498-001	DAMPER COLLAR
1	1	19	265467-001	BY-PASS DAMPER
1	1	20	265468-001	BY-PASS KNOB - DAMPER
1	1	21	265796-001	COMPRESSION SPRING
1	1	22	465499-001	COLLAR BLANK
-	1	23	265160-002	HUMIDISTAT, ELECTRONIC
1	-	23	265160-001	HUMIDISTAT, MECHANICAL
1	1	24	153296-006	TUBING - 1/4" O.D. X 16.5" LG"
-	1	25	266249-001	THERMISTOR BRACKET
1	1	26	266256-001	MAIN BASE DRILL DETAIL CB300
1	-	27	63667	TRANSFORMER - 120V-24V (Not Shown)



TRION[®]
Air Purification Systems

Trion[®]

101 McNeill Rd. | Sanford, NC 27330

P: 800.884.0002 | F: 800.458.2379 | www.trioniaq.com | customerservice@trioniaq.com
