

This Owner's Manual is provided and hosted by [Appliance Factory Parts](#).



Phoenix RBW5001 Owner's Manual

[Shop genuine replacement parts for Phoenix RBW5001](#)



[Find Your Phoenix Evaporative Cooler Parts - Select From 103 Models](#)

----- Manual continues below -----

RESIDENTIAL EVAPORATIVE AIR COOLERS

Economical and Dependable Cooling Power For Your Home

Air + Water

ENERGY EFFICIENT EVAPORATIVE COOLING

Environmentally Friendly

The simple concept of mixing air and water produces powerful, energy efficient cooling that is both economical and environmentally friendly. The Frigiking coolers are your best choice for whole home cooling and can provide years of comfort and economical trouble-free operation



U.L. Listed Models
also available



WINDOW COOLERS



MULTI-USE COOLERS



FRIGIKING[®]
EVAPORATIVE AIR COOLER

ENVIRONMENTALLY FRIENDLY SOLUTIONS TO

Maximize Cooling Minimize Cost



PRECISION CRAFTED Engineered to Last

It's hard to beat our 4-pad bottom discharge model for maximum cool air at minimum energy cost. Ideal for roof installation, this cooler features a unique full closing damper to seal the unit and prevent winter heat loss.

The versatile side discharge unit is perfect for either roof or thru-the-wall installations. Our wide angle pad lancing provides maximum air intake for maximum efficiency. Includes factory 120V pump, float and bleed-off and your choice of a 1 or 2 speed motor.



FRIGIKING[®]
EVAPORATIVE AIR COOLER

MIRROSCOPIC™ FINISH



3Ra (Roughness Average)



MIRROSCOPIC™ Finish

3Ra (Roughness Average)

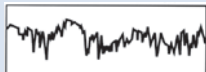

Industry Standard Finish

MIRROSCOPIC™ BLOWER SHAFT FINISHING PROCESS

Our exclusive MIRROSCOPIC Blower shaft finish process yields a 90% improvement over the industry standard "ground finish". This means quieter operation as well as longer bearing and shaft life for your cooler!

EASY ACCESS GRAVITY-HELD DOORS

Easy to remove access doors reduce maintenance time.

EASY SETUP

Junction box allows for easy plug-in connections of motor and pump (2200-6500 CFM).

PREVENTS WINTER HEAT LOSS

Down Discharge models include our exclusive slide damper to seal the duct and prevent winter heat loss.

RELIABLE MOTOR

High-torque, belt driven motors are recognized by Underwriters Laboratories (U.L. Listed).

Note: Motors Sold Separately

QUIET OPERATION

Oversized balanced blower wheels generate maximum air while providing quiet operation.

PEBLAR XT PROTECTIVE POWDER COATING

Our exclusive Peblar XT surface preparation is the highest quality and most costly outdoor architectural grade finish used in the industry to date. This attractive, multi-layered bonded treatment protects your cooler against corrosion and assures years of reliable service.

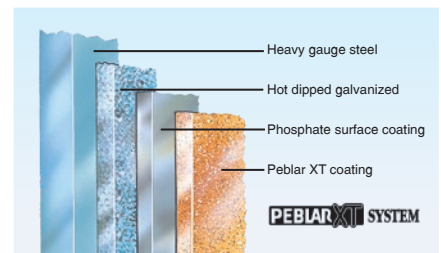



Economical & Trouble Free

All stages of our manufacturing emphasize quality, efficiency and every Frigiking Air Cooler is built to the most exacting standards. The cabinet design with a deep drawn bottom pan, is constructed with hot dipped galvanized steel and coated with an attractive appliance type finish. Every component is

engineered for reliable performance, so your cooler will last through the years of cooling comfort with a minimum of maintenance.

In short, the Frigiking cooler is your best choice for years of comfort and economical trouble-free operation.



Specifications Motor sold separately

Model Number	Cooling Capacity		Air Delivery CFM (Cubic Feet Per Minute)						Electrical Specifications				
	Industry Std. Rating	Cubic ft. Area	0.0"	0.1"	0.2"	0.3"	0.4"	0.5"	HP	Speed	Phase	Hz	Volts
FD/FS 350	3000	6600	2180	2085	1980	1860	1685	1490	1/3	1	1	60	120
	3000/2000	6600							1/3	2	1	60	120
FD/FS 450	4000	8000	3130	2922	2702	2478	2250	2010	1/3	1	1	60	120
	4000/2665	8000							1/3	2	1	60	120
	4500	9000	3660	3464	3268	3072	2876	2680	1/2	1	1	60	120/240
	4500/3000	9000							1/2	2	1	60	120/240
FD/FS 650	5500	11000	4130	3966	3802	3636	3469	3305	1/2	1	1	60	120/240
	5500/3365	11000							1/2	2	1	60	120/240
	6500	13000	4710	4546	4382	4218	4052	3890	3/4	1	1	60	120/240
	6500/4330	13000							3/4	2	1	60	120/240

When specifying or ordering U.L. Listed models, add a "U" prefix to the front of the appropriate model number. In order to maintain this U.L. Listed designation, these models must be used in conjunction with PMI supplied motor kits and pumps.

Example: **UFD650**

Frigiking Engineering Data

Model Number	Cabinet			Dimensions									Blower Wheel		Pad Frame		Pad Filter Dimensions			Ship. Weight	Oper. Weight
	A	B	C	D	E	F	G	H	J	K	P	R	Dia	Width	Height	Width	No.	Width	Height		
FD/FS 350	32	28	28	16	16	3 1/4	6	14	4 1/4	10 1/4	--	--	13 1/4	13	26	22	4/3	21	25	108	150
FD/FS 450	36	34	34	17 7/8	17 7/8	4 1/2	8 1/16	17	5 1/4	12 1/4	--	--	16 1/8	15 7/8	30	28	4/3	28	29	138	215
FD/FS 650	42 1/4	37	37	19 7/8	19 7/8	3 7/8	8 9/16	8 1/2	6	14 1/4	--	--	19 1/8	17 7/8	37	31	4/3	30	35	177	290

FRIGIKING EVAPORATIVE COOLERS and components are designed and tested in accordance with one or more of the following standards or agencies. **AIR DELIVERY** - data published derived from tests conducted in accordance with A.M.C.A. (Air Movement and Control Assoc.) standard 210. **ASPEN PADS** - built to federal specification PP-E-911 for Type 1, Class A, Grade 4. **SEALANT** - water immersion per ASTM D870. **FLEXIBILITY** - per ASTM D756. **CORROSION RESISTANCE** - per ASTM B117. **PENCIL HARDNESS** - per ASTM D3363. **IMPACT RESISTANCE** - per D2794. **FLEXIBILITY** - per ASTM D522. **SPECULAR GLOSS** - per ASTM 523. **SURFACE BURNING CHARACTERISTICS** - of building materials (best rating) per UL 723 and ASTM E-84. **PUMPS** recognized under UL standard #778 for operating water pumps with thermal overload and locked rotor protection. **POLYMERIC MATERIALS** listed in accordance with UL 94 and 746C. **MOTORS** recognized under UL component standard #1004 for motor certification. **MOTORS** tested under UL standard #507 for locked rotor and heat rise protection.

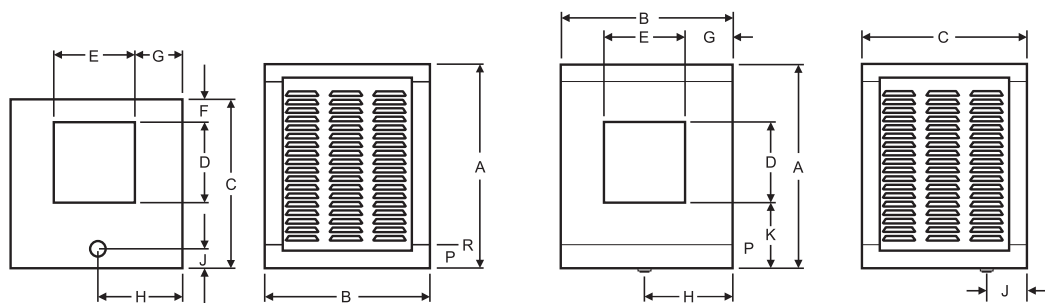

Bottom Discharge

Side Discharge

Window Coolers

Put Your Energy Costs On Ice

WITH FRIGIKING WINDOW COOLERS

Engineered to give you more cooling power for less money! The Frigiking line of evaporative window coolers deliver more CFM (cubic feet per minute of air) for each watt of energy consumed than comparative competitive models. This means quicker cooling, as it absorbs heat from the air faster. Frigiking can cost between 15% to 28% less to operate and achieve equivalent results. Ask your qualified contractor about the benefits of the Frigiking line of Window Coolers.



Specifications

Model Number	Area Cooling Capacity Sq/Ft	Blower Wheel		Motor		
		D	W	HP	Speed	Volt
WH2906	100 - 400	8	8	1/8	2	120
BW3004	400 - 600	8	8	1/4	2	120
BW3501	600 - 800	13 1/4	13	1/3	2	120
BW4002	700 - 1000	13 1/4	13	1/3	2	120
BW4502	700 - 1200	16 1/8	15 7/8	1/3	2	120
BW5002	1200 - 1600	16 1/8	15 7/8	1/2	2	120
RBW5001 [†]	1200 - 1600	16 1/8	15 7/8	1/2	2	120

[†] The model RBW5001 includes convenient remote control functionality.

REMOTE CONTROL COOLING!

The model RBW5001 includes a convenient remote control for easy remote control cooling.



RBW5001



The Efficiency of Rigid Media

THE CONVENIENCE OF A WINDOW COOLER

This fully assembled U.L. Listed evaporative window cooler is an economical unit which provides the higher performance of the rigid media coolers. With this 1/2 HP, 2 speed motor, the BW5502 provides cooler air than its aspen equivalent.



Specifications						
Model Number	Area Cooling Capacity Sq/Ft	Blower Wheel		Motor		
		D	W	HP	Speed	Volt
BW5502	1400 - 1800	16 1/8	15 7/8	1/2	2	120

3000, 4000, & 5000 Series

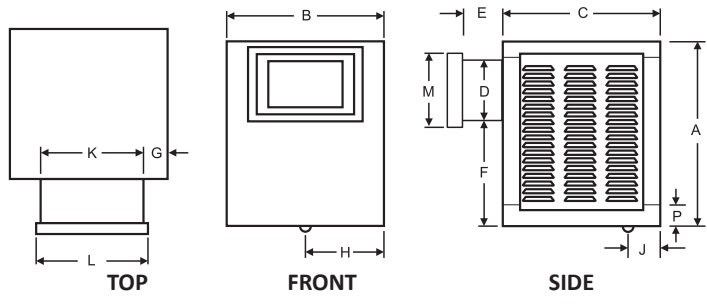

2000 Series

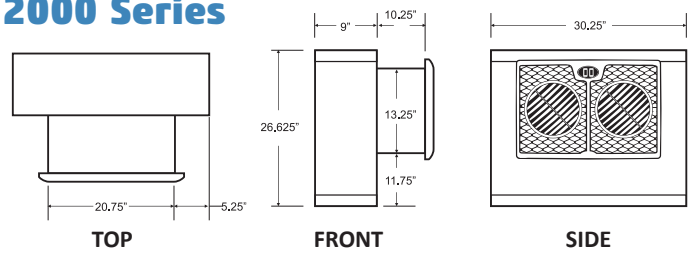

Window Cooler Engineering Data

Model Number	Cabinet			Dimensions										Ship Weight w/Motor
	A	B	C	D	E	F	G	H	J	K	L	M	P	
WH2906	26 5/8	31 1/8	9	13 1/4	10 1/4	11 3/4	5 1/4	--	--	20 3/4	21 1/2	14 7/8	3 1/4	60
BW3004	25	28	28	13 1/4	10	8 3/8	3 3/4	14	4 1/2	20 3/4	21 1/2	14 7/8	3 1/4	90
BW3501	32	28	28	13 1/4	10	15 1/2	3 5/8	14	4 1/2	20 3/4	21 1/2	14 7/8	3 1/4	115
BW4002	36	28	28	13 1/4	10	19 1/2	3 5/8	14	4 1/2	20 3/4	21 1/2	14 7/8	3 1/4	120
BW4502	36	34	34	13 1/4	10	19 1/2	6 5/8	17	5 5/8	20 3/4	21 1/2	14 7/8	3 1/4	143
BW5002	36	34	34	13 1/4	10	19 1/2	6 5/8	17	5 5/8	20 3/4	21 1/2	14 7/8	3 1/4	144
RBW5001	36	34	34	13 1/4	10	19 1/2	6 5/8	17	5 5/8	20 3/4	21 1/2	14 7/8	3 1/4	144
BW5502	36	33 1/4	27 1/4	13 1/4	10	19 1/2	6 1/4	17	4 1/2	20 3/4	21 1/2	14 7/8	3 1/4	150

Mobile Coolers



Mobile Family of Evaporative Coolers



MOBILE COOLING - ANYWHERE YOU NEED IT

All CoolTool Mobile Evaporative Coolers come complete with locking caster set, adjustable leg kit and garden hose adapter to provide the most flexibility. Operated by easy control rocker switches, the powerful 120V motor delivers cool air with twin 360° directional grilles. Our exclusive PEBLAR XT cabinet finish will assure many years of reliable service.



CTV1
Cool up to 1,000sqft
1/3 HP - 2 spd

CTV21
Cool up to 1,400sqft
1/2 HP - 2 spd

Shown with legs & duct Extension for permanent installation.

Mobile Configuration

FEATURES

- All models have 9.5 gallon internal water reservoir
- Equipped with Aspen media pads
- Simple controls and quiet operation
- Dual inlet design
- Exclusive Peblar XT finish
- All models come with both locking caster wheel set and adjustable leg kit
- CTV21 is a multi-purpose cooler for both through the wall or mobile cooling

Feature	CTV1	CTV21
Cooling Capacity	1,000 sq. ft.	1,400 sq. ft.
Fan Type	Centrifugal	Centrifugal
Width	30 in	30 in
Height	40.5 in	48.5 in
Depth	30 in	30 in
Ship Weight	156 lbs	176 lbs
Electrical	120V	120V
Horse Power	1/3HP	1/2HP
CFM	2,100	2,500

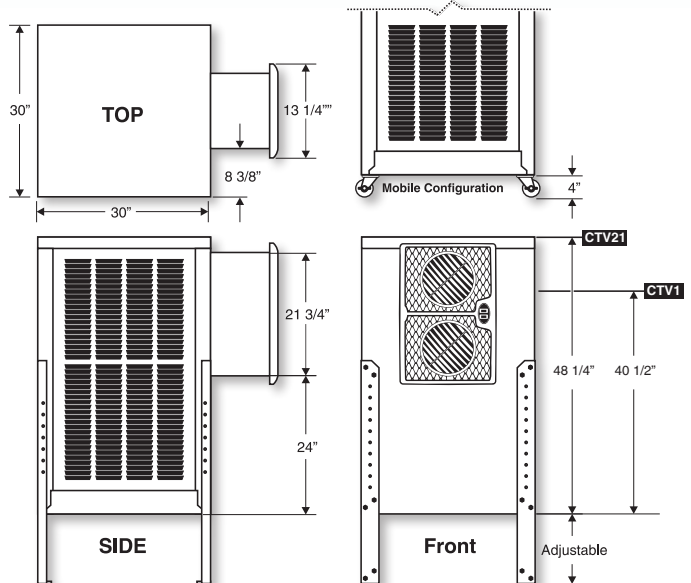

Cooler Accessories

Leg Kits

GIVE YOUR EVAPORATIVE AIR COOLER A LEG-UP

Our leg sets are heavy duty and finished with the same superior finishing technique used on all of our evaporative cooling products. Our Legs kits - a simple and reliable product you can trust!

Leg Kit Package Includes:

- 2 x 29" Legs
- 2 x 19" Legs
- 4 x Mounting Feet
- Hardware for mounting the legs to your cooler



ALL EVAPORATIVE COOLERS ARE NOT CREATED EQUAL

Different size units require different flush cycles and time periods to work properly. Custom-Clean™ gives you the ability to set a customized cleaning cycle that meets the needs of your specific evaporative air cooler.

8 Custom Cleaning Cycles

Four dump frequency settings and two cleaning cycle time periods combine for a total of 8 custom settings which are designed to meet the needs of your individual evaporative air cooler.

- Installation is easy
- Reduces harmful scale build-up and extends the life of your cooler
- Keeps your cooler cleaner longer and retards growth of odor causing bacteria
- Optimizes cleaning effects and water consumption to the size of your cooler

Nth Degree

The Nthdegree™ digital thermostat control package is designed to operate any whole house cooler.

The Nthdegree™ will cycle the fan between low, high or off to maintain the temperature using the least amount of energy possible. Just set the temperature, and let Nthdegree™ take care of the rest.



- U.L. Listed
- Works with ANY Cooler with up to a 1HP motor operating at 120V or 240V
- Easy to install
- Rain-tight NEMA Control Box
- Provides a Pre-Wet Cycle
- Energy Saving Features

Programmable Drain Pump

By replacing the "bleed-off" system with the innovative programmable Drain Pump (PDP12), you can save as much as 3000 gallons of water per month. That's enough to fill a standard swimming pool in just one cooling season!

Set the clean frequency to 2,4,6 or 8 hours and choose a run time of 5 or 9 minutes, depending on your specific needs.



- Prevents mineral build-up
- Reduces bacterial growth
- Reduces maintenance and eliminates chemical additives and cleaners
- Extends pad life
- Improves efficiency
- Easy plug-in installation
- Full 2 year warranty

Cooler Accessories

Model #	Description
RSK	Rotary Switch Kit (2 spd. mtrs.) (wall mount)
TGK	Mobile Home Grille Kit (includes all wiring)
TG	Mobile Home Grille (grille only)
GHA	Garden Hose Adapter
PDP12-6	Programmable Drain Pump 120 V.
PCS230	Power Cleaning System 240 V.
BDC100-12	120 V. Drain Cord

Model #	Description
WGC	Window Cooler Grille Cover
NDS	Low Voltage Thermostat
LR100	Leg Set Kit for Round Cornered Units
LS100	Leg Set Kit for Square Cornered Units
GP120	120 V Drain Pump & Thermostat with Timer Cord
GP240	240 V Drain Pump & Thermostat



FRIGIKING®
EVAPORATIVE AIR COOLER

VALUE & COMMITMENT

We are a designer, manufacturer, and distributor that primarily produces evaporative cooling products designed for the comfort of the home or business.

Values here begin with our employees, customers, and suppliers. We strive each day to treat those involved with us with respect, while performing our duties with integrity. We put a premium on those values to best serve our industry in a manner that will deliver quality in everything we do. The phone calls, e-mails, meetings, along with the products and the services, are designed to deliver these values consistently every day.



Phoenix Manufacturing Inc.

3655 East Roeser Road
Phoenix, Arizona 85040

Phone: 602-437-1034

Fax: 602-437-4833

FK001-18-V00
MADE IN U.S.A.

www.phoenixmanufacturing.com