



OWNER'S MANUAL

MANUAL DE PROPIETARIO

MODEL # _____
SERIAL # _____

PD/PH 4801
PD/PH 6801
PD/PH 6231
PD/PH 4231

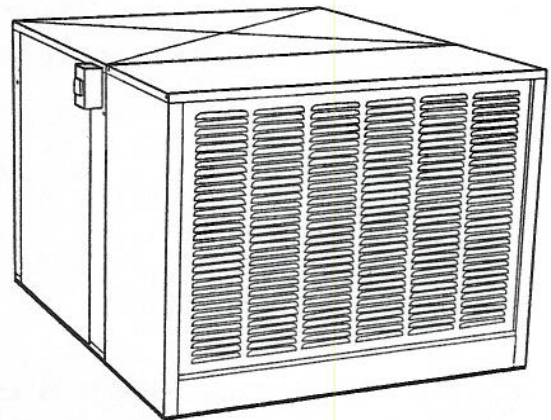

READ AND SAVE THESE INSTRUCTIONS LEA Y CONSERVE ESTAS INSTRUCCIONES

- INSTALLATION
INSTALACIÓN
- MAINTENANCE
MANTENIMIENTO

- SAFETY
SEGURIDAD
- TROUBLE SHOOTING
TRAZANDO FALLAS

Congratulations: You have purchased a product of superior performance and design, which will give the best service when properly installed, operated and maintained.

FELICITACIONES: Usted acaba de comprar un producto con un diseño y rendimiento superior, que le dará el mejor servicio cuando sea propiamente instalado, operado y mantenido.

WARNING

- **WARNING:** To Reduce The Risk Of Fire Or Electrical Shock, Do Not Use This Fan With Any Solid State Speed Control Device.
- **Cooler motor, pump, cabinet and junction box must be grounded in accordance with all local and national codes. A ground wire must be used between the cooler and the power source.**
- Always disconnect electrical power to the cooler before working on cooler.
- Do not remove side panels while cooler is running.
- Do not locate cooler near exhaust or vent pipes as odors or fumes may be drawn into the unit.
- Be sure cooler is connected to proper line voltage stamped on blower motor and pump motor specification plate. NOTE: IMPROPER VOLTAGE WILL VOID MOTOR WARRANTY.
- THE USE OF AN ANODE DEVICE OR CHEMICAL ADDITIVES OR COOLER TREATMENTS IN THIS COOLER WILL VOID THE WARRANTY.

ADVERTENCIA

- **ADVERTENCIA:** Para Reducir El Riesgo De Incendio O Toque Electrico, No Use Este Enfriador Con Ningun Dispositivo Para Controlar La Velocidad.
- **Motor del enfriador, bomba, gabinete Y caja de empalme tienen que ser conectados a tierra electrica de acuerdo con todos los codigos locales Y nacionales. Un alambre de tierra debe ser usado entre el enfriador Y la fuente de poder.**
- Siempre desconecte la corriente del enfriador antes de cualquier reparacion.
- No remueva los filtros cuando la unidad esta funcionando.
- No instale el enfriador cerca de extractores o tubos de venteo ya que olores o vapores pueden entrar a la unidad.
- Asegurese que el enfriador sea conectado a la linea de voltaje apropiado como lo indica la placa de el motor Y la bomba. Nota: EL USO DE VOLTAJE IMPROPIO ANULA LA GARANTIA DEL MOTOR.
- EL USO DE ANODOS, LIMPIADORES, TRATAMIENTOS PARA ENFRIADORES EN ESTA UNIDAD ANULA LA GARANTIA.

INSTALLATION • INSTALACION

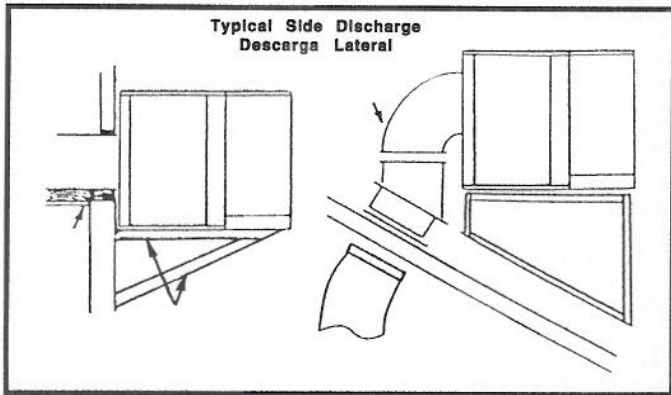

Installation demands connection of blower opening to existing air ducting system or to a dropper duct with a ceiling diffuser. In either instance, building modification is necessitated. The bottom discharge cooler is always mounted on the roof of the structure. You will require a roof stand, roof jack, flexible duct and collar to connect to existing ductwork.

DO NOT DRIVE NAILS OR SCREWS INTO BOTTOM OF THE WET SECTION OF THE COOLER. THIS WILL CAUSE IT TO LEAK WATER AND WILL VOID THE WARRANTY.

Whenever the cooler is mounted, the surface must be level.

When coolers are installed in the city of Los Angeles they must only be installed outside of buildings.

All of the electrical components that are part of this product shall be either currently listed as part of the equipment for intended use by a Los Angeles City recognized electrical testing laboratory or currently approved by the City of Los Angeles Electrical Testing Laboratory.

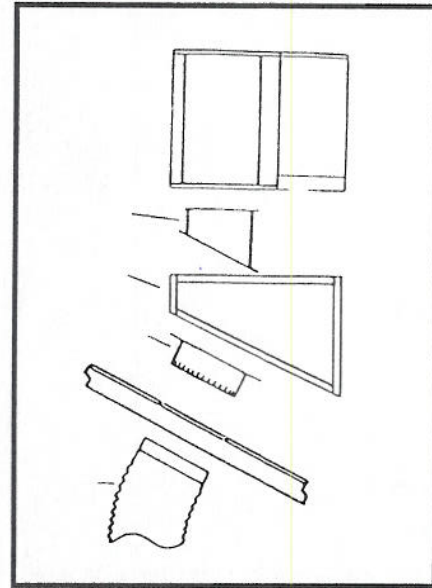

La instalacion demanda la conexion de la descarga de la unidad a el existente sistema de ductos o a una caida de ducto con difusor de cielo. En ambos casos, la modificacion del edificio es necesaria. El enfriador de descarga inferior siempre se monta en la estructura del techo. Para esto se requiere un soporte de angulos, soporte de lamina ducto flexible Y un collar para conectarlo al ducto existente.

NO CLAVE CLAVOS O TORNILLOS EN EL FONDO DE LA SECCION HUMEDA DEL ENFRIADOR. ESTO CAUSARA FUGAS DE AGUA Y ANULARA LA GARANTIA.

Cuando un enfriador es montado, la superficie debe estar nivelada.

Cualquier enfriador que sea instalado en la ciudad de Los Angeles tiene que ser instalado solamente en el exterior del edificio.

Todos los componentes electricos que son parte de este producto deben estar corrientemente listados como parte del equipo para el uso que se intente por el laboratorio de pruebas electricas de La Ciudad De Los Angeles O Corrientemente Aprobado Por Este.

INSTALLATION • INSTALACION

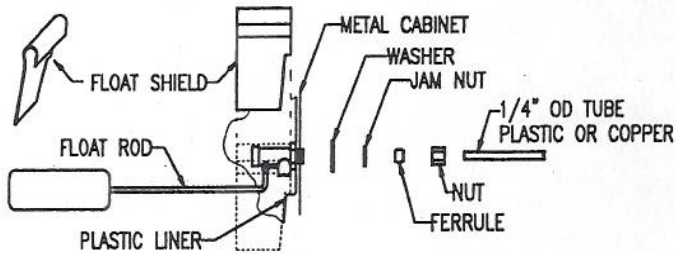

Water Connection

1. Install float in hole in the side of bottom pan opposite the pump. See parts illustration to route the water line. Connect per above sketch.
2. Turn on the water to the cooler and set float valve to maintain 2½ inch water depth. The float valve is adjusted by bending the float valve rod.
3. Bleed-off: Bleed off is helpful to prevent scale from building up in the cooler. A bleed-off adapter tee and tube are furnished with the cooler for this purpose, run bleed-off line to a proper drain.
4. Install float shield over float valve per above illustration

Note: *Evaporative coolers should not be connected to a "soft" water system.*

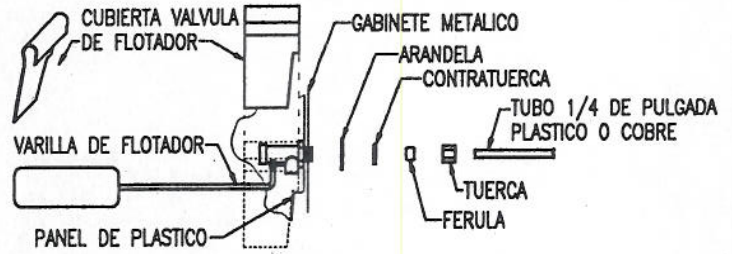

Conexión Del Agua

1. Instale el flotador en el agujero proveido en el lado del deposito opuesto a la bomba. Conecte el tubo del agua de acuerdo con la figura de arriba Y guie el tubo de acuerdo con la ilustración de partes.
2. Abra el agua Y ajuste el flotador para mantener un nivel de 2 pulgadas de agua. El flotador se ajusta doblando la varilla de este.
3. El desagüe ayuda a prevenir el acumulamiento de sales en el enfriador. Un adaptador "T" y tubo de sangria estan incluidos en el enfriador para este proposito, guie la linea de sangria a un drenaje apropiado.
4. Instale la cubierta sobre la valvula como se indica arriba.

Nota: *Enfriadores por evaporacion no deben ser conectados a un sistema de "agua blanda".*

Drain Bushing

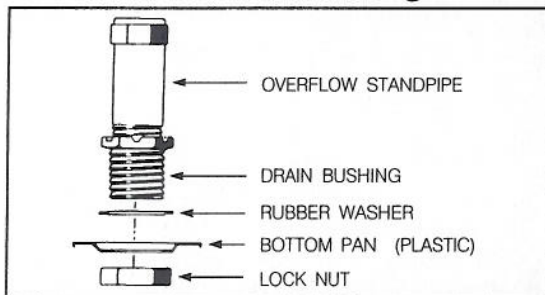

Insert drain bushing through the hole in the cooler bottom pan. Attach nut securely, and tighten, do not use a wrench. Attach hose and adapter from drain pump. See illustration on page 8.

Buje De Drenaje

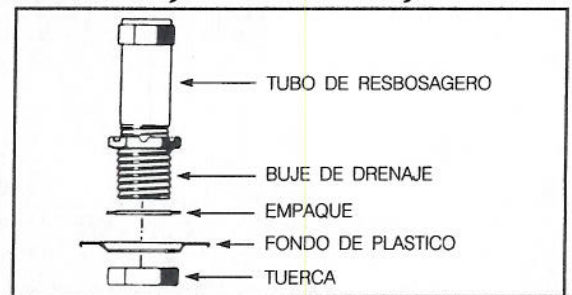

Inserte el buje de drenaje a traves de el agujero en el fondo de el enfriador. Atornille la tuerca con la presion de la mano, no use herramienta. Vea ilustración en pagina 8.

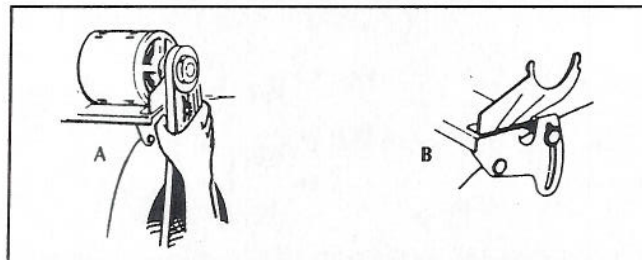

Blower Belt Adjustment

Correct belt adjustment and alignment is important as incorrect adjustment increases power consumption and shortens belt and motor life. Install belt over motor and blower pulleys. (A) Check belt tension by squeezing (deflecting) belt. Proper tension will allow deflection of ½ to ¾ inch. (B) To increase or decrease belt tension, loosen bolt in slot of motor support bracket. Adjust belt to desired tension and retighten bolt.

Ajuste De Banda

El ajuste correcto de la banda y alineamiento es importante ya que el ajuste incorrecto aumenta el consumo de corriente y acorta la duracion de la banda y motor. Instale la banda sobre ambas poleas. (A) Revise la tension de la banda apretandola (defleccionandola). Una tension apropiada permitira una deflección de ½ a ¾ de pulgada. (B) Para aumentar o disminuir la tension de la banda afloje el tornillo del soporte del motor. Ajuste la banda a la tension deseada y apriete el tornillo.

ELECTRICAL CONNECTIONS FIELD WIRING INSTRUCTIONS

I. MAIN POWER SUPPLY

THIS COOLER IS PREWIRED FOR 115 VOLT OR 230 VOLT, 60HZ POWER ONLY. MAKE SURE YOU CONNECT YOUR COOLER TO THE CORRECT VOLTAGE.

- A. Remove the control box cover - (4) screws.
- B. Remove 2" x 4" water tight junction box (3), junction Box Cover (5), switch (4) and 1/2" chase nipple (1) and jam nut (2) from the parts carton.
- C. Mount junction box to the cooler as follows:
 - 1. Insert chase nipple (1) into 7/8" hole from the inside of the cabinet (8) and fasten it tightly to the cooler with the 1/2" conduit jam nut (2).
 - 2. Screw the Junction box (3) onto the thread of the chase nipple (1) until tight and aligned vertically.

CAUTION: Make sure the power is off to the supply wires before proceeding with the next steps.

- D. Connect ground wires as follows; Refer to wiring diagram inside the control box cover.
 - 1. Pull the green ground wire harness from the cooler through the chase nipple (1).
 - 2. Attach the eyelet terminal of the ground wire harness and the ground wire from the power supply to the disconnect box (3) using the #10 Green Ground screw supplied. Attach the spade terminal of the ground wire assembly to the switch (4) ground screw.

- E. Connect Line Leads as Follows:

- 1. 115 Volts Coolers: Pull the black and white jumper wires from the cooler through the chase nipple (1) into the junction box (3). Attach the black jumper wire to one screw terminal on the switch (4). Attach the hot supply lead to the other screw terminal on the switch. Attach the white jumper wire from the cooler to the white or neutral wire from the supply line using the orange wire nut supplied.
- 2. 230 Volt Coolers: Pull the black and orange jumper wires from the cooler through the chase nipple (1) into the junction box (3). Fasten the black wire to one load screw on the switch. Fasten the orange jumper wire to the other load screw on the switch. Fasten the two supply leads to the two line screws on the switch.

- F. Mount the switch (4) onto the junction box (3) with the on position up and the ground screw on the switch down.

- G. Mount the junction box cover (5) onto the junction box making certain that the gasket fits properly all the way around the periphery of the junction box (3).

INSTRUCCIONES DE ALAMBRADO CONEXIONES ELECTRICAS

I. FUENTE DE PODER PRINCIPAL

ESTE ENFRIADOR HA SIDO ALAMBRADO PARA OPERAR CON CORRIENTE DE 115 VOLTIOS 60HZ SOLAMENTE

- A. Remueva la tapadera de la casa de control - (4) tornillos.
- B. Remueva la caja impermeable 2" x 4" de empalme (3), tapadera de caja (5), interruptor (4) Y el niple de encaje de 1/2" (1) el niple de encaje de 1/2" (1) contratuerca (2) de la caja de cartón.
- C. Monte la caja de empalme como sigue:
 - 1. Coloque el niple de encaje (1) en el agujero de 7/8" de adentro del gabinete (8) Y asegurelo con la contratuerca (2).
 - 2. Atornille la caja de empalme (3) en la rosca de el niple (1) hasta que quede apretada y verticalmente alineada.

PRECAUCIÓN: Asegurese que la corriente está desconectada antes de proceder con los siguientes pasos.

- D. Conecte los alambres de tierra como sigue; Vea el diagrama de alambrado dentro de la tapadera de la caja de control.
 - 1. Jale el alambre verde através de el niple (1).
 - 2. Conecte la terminal de ojillo del alambre de tierra y el alambre de tierra de la fuente de poder a la caja de empalme (3) usando el tornillo verde de tierra #10 incluido. Conecte la terminal de espada del alambre de tierra al tornillo de tierra del interruptor (4).

- E. Conecte Los Alambres de La Linea de Corriente Como Sigue:

- 1. Enfriadores de 115 Voltios: Jale los alambres de cierre negro y el blanco del enfriador através del niple (1) hacia la caja de empalme (3). Conecte el alambre negro de cierre a un tornillo de la terminal de la interruptor (4). Conecte el alambre de corriente a el otro tornillo en la terminal del interruptor. Conecte el alambre de cierre blanco del enfriador al alambre blanco o neutral de la linea de corriente usando el cono aislante anaranjado proveido.
- 2. Enfriadores de 230 Voltios: Jale los alambres de cierre negro y el anaranjado del enfriador através del niple (1) hacia la caja de empalme (3). Conecte el alambre de cierre negro a una de las terminales de carga (Load) del interruptor. Conecte el alambre de cierre anaranjado a la otra terminal de carga del interruptor. Conecte los dos alambres de corriente a las terminales marcadas supply (Fuente) del interruptor.

- F. Monte el interruptor (4) en la caja (3) con la posición de prendido hacia arriba y el tornillo de tierra hacia abajo.

- G. Monte la tapadera de la caja (5) asegurandose que el empaque cierre el periferio de la caja (3).

II. THERMOSTAT CABLE INSTALLATION

The thermostat for this cooler is connected to the cooler by means of a 6 conductor thermostat cable (not provided). Type CL2, 18 or 20 gauge, UL listed thermostat wire is recommended.

- A. Route one end of the thermostat cable (9) through the 1/2" hole in the corner post on the left side of the access door and then through the 1/2" hole in the left end of the control box.
- B. Insert the individual conductors of the thermostat wire (9) into the terminal block connections on the right side of the printed circuit board (6). Connect colored wires to terminals as follows: white to "C", brown to "H", red to "L", green to "P", yellow to "D", and blue to "R". Tighten screws.
- C. Install strain relief bushings (7) over the thermostat cable into the 1/2" holes in the corner post and control box, allowing a slight amount of "slack", do not stretch the thermostat cable tight. Replace the control box cover - tighten the four screws.
- D. Select a location for the thermostat
 1. Mount the thermostat about 5 feet above the floor.
 2. Mount the thermostat on a partitioning wall, not an outside wall.
 3. Do not mount it near sources of heat.
 4. Do not mount it in the direct draft of cooler air registers.
 5. Avoid dead air spaces which have little air circulation.
- E. Install the thermostat using the "Mounting Instructions for Thermostat" furnished with the cooler.

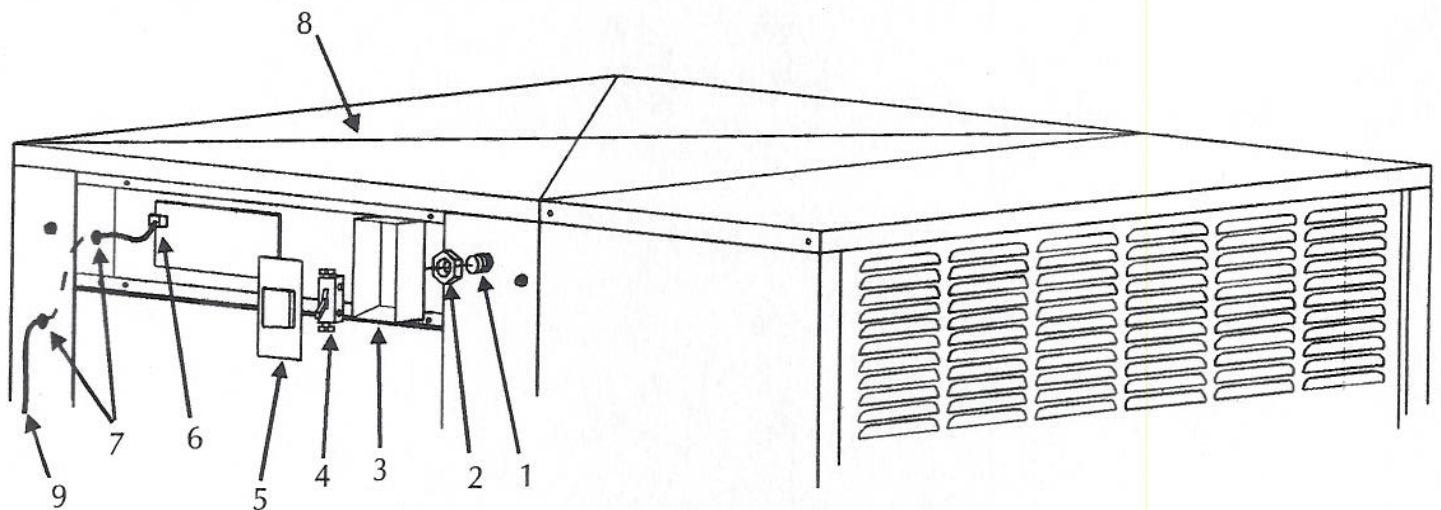

1. Chase Nipple
2. Jam Nut
3. Junction Box
4. Switch
5. Junction Box Cover

6. Printed Circuit Board
Thermostat Connector
7. Strain Relief Bushings
8. Cooler cabinet
9. Thermostat Cable

II. INSTALACIÓN DEL CABLE DEL TERMOSTATO

El termostato está conectado al enfriador por medio de un alambre plano de 6 conductores tipo telefono de 66 pies de largo (9) incluido en la caja.

- A. Guíe una punta del cable de termostato (9) através del agujero de 1/2" en el poste de el lado izquierdo de la puerta de acceso y después através del agujero de 1/2" de la caja de controles.
- B. Inserte el conector en el socket proveido en el lado izquierdo del circuito impreso (6) en la caja de controles.
- C. Instale el sujeta cable (7) sobre el cable y en los agujeros de 1/2" en la esquina del gabinete y en la caja de controles. Dejando una prequena cantidad de cable, no estire el cable del termostato. Ponga la tapadera de la caja del control con los cuatro tornillos.
- D. Seleccione el lugar para el termostato.
 1. Montelo a 5 pies del piso.
 2. Instale el termostato en una pared interior no en una pared que de al exterior.
 3. No monte el termostato cerca de una fuente de calor
 4. No lo monte en la corriente de aire directa de las parrillas del enfriador.
 5. Evite espacios muertos de aire que tengan poquita circulación.
- E. Instale el termostato usando las "Instrucciones para montar el termostato" proveidas con el enfriador.

1. Niple De Encaje
2. Contratuerca
3. Caja De Empalme
4. Interruptor
5. Tapadera

6. Conector De Termostato
En El Circuito Impreso
7. Sujeta Cables
8. Gabinete
9. Cable De Termostato

MAINTENANCE • MANTENIMIENTO

The cooler should be serviced at least once a year and more often if required. This includes cleaning, oiling, belt adjustment (if required) and pad replacement.

Cleaning:

1. Remove access doors and inlet air louvers.
2. Remove the overflow standpipe from the drain bushing and allow the reservoir to empty.
3. Use a hose with a nozzle and spray the external inlet surface of the Celdek pads and plastic surfaces to remove scale, dirt, and foreign material. A soft brush may be used to assist removal of materials.
4. Clean the internal surfaces of the cooler with a cloth and clean water.
5. Rinse the cooler bottom pan thoroughly.
6. Clean the pump screen and remove any foreign material between the pump and the hose. To remove any foreign material in water distributor tube, remove plastic plug from end of tube and flush tube with water. Replace plug.
7. Touch up any scratches or bare spots on the metal surfaces of the cooler with a suitable rust resistant paint.

Oiling:

At least once a year you should fill the oil cups on the blower shaft bearings with SAE #20-30 NON DETERGENT OIL. Oil the motor with 30-35 drops of SAE 20-30 Non detergent oil per bearing every two years.

Belt Adjustment:

Check belt tension. Readjust, if loose, per instructions in the Installation section of this manual.

Pad Replacement:

The Celdek pad media should be removed and replaced if scale has built up on the outside which will restrict the airflow and cannot be removed using the method described in the "Cleaning" section above.

Replacement media is available through your dealer. Install the replacement media in the same manner as the original media was installed. Make sure that the painted stripe on the media is properly located. See illustration below.

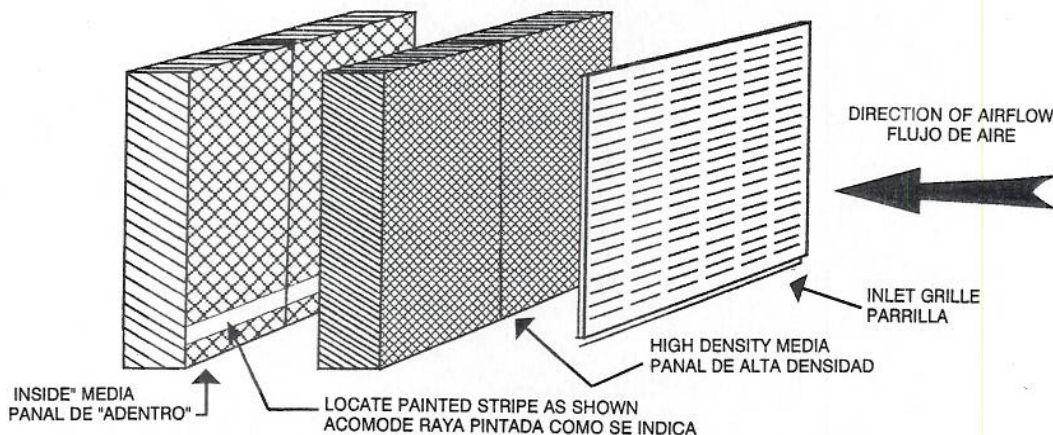

El enfriador requiere servicio al menos una vez por año o mas si es necesario. Esto incluye limpieza, lubricacion, ajuste de banda (si esta floja) y reemplazo del panal.

Limpieza:

1. Remueva las puertas de acceso y la parrilla.
2. Remueva el rebosadero de el buje de drenaje y vacie el deposito de agua.
3. Use una manguera y rocíe la superficie de la parte externa del panal con presion y las superficies de plastico para remover escama, tierra, y material extraño. Puede usar una brocha blandita para limpiar el panal.
4. Limpie las superficies internas del enfriador con un trapo Y agua limpia.
5. Enjuague el fondo del enfriador completamente.
6. Limpie el filtro de la bomba Y remueva objetos que obstruyan el adaptador de la manguera en la bomba. Asimismo limpie el adaptador del distribuidor de agua a la manguera. Remueva el tapon de plastico del tubo y aplique agua a presion. Ponga el tapon
7. Pinte raspaduras Y puntos expuestos en las superficies de metal del enfriador con un recubrimiento resistente a corrosion.

Lubricacion:

Al menos una vez por año usted debe llenar las aceiteras en las chumaseras de la flecha con aceite de motor SAE #20-30. NO DETERGENTE. Aciete el motor con 30-35 gotas de aciete SAE 20-30 no detergente por chumatera cada dos años.

Ajuste De Banda:

Revise la tension de la banda. Reajuste, si esta floja, siguiendo las instrucciones en la seccion de operacion de este manual.

Reemplazo del Panal (Celdek):

El panal celdek debe ser removido y remplasado si la escama se a acumulado en la superficie externa y restringe el flujo del aire y no puede ser removida usando los metodos descritos en la seccion de "limpieza".

Remplazo del panal es disponible por medio de su distribuidor. Instale el panal de remplazo en la misma forma que la original. Asegurese que la raya pintada en el panal quede propiamente instalada. Vea la ilustración abajo.

OPERATING INSTRUCTIONS FOR THE PRO-STAT THERMOSTAT CONTROL

SPECIAL FEATURES

- All information is saved during power failure or system shut-down and system returns to last operating mode when power is restored
- Programmable presets and 24 hour delay timer
- Programmed “soft” transition from high to low fan
- Automatic Pro Clean System
- No batteries required
- Large LCD display
- Temperatures displayed in either °F or °C

System ON/OFF Button

Press the ON/OFF button to turn the cooler on or off. The last used settings of COOL/VENT, set point, and FAN (AUTO, HIGH, LOW) will be displayed

FAN Button

Pressing the FAN button will select either AUTO, HIGH, or LOW fan speeds. In AUTO COOL, the cooler starts on HIGH when the room temp is 2 °F above the set point and starts on LOW when the room temperature is 1 °F above the set point. When the room temperature is 1 °F below the set point, the cooler shuts off. In either HIGH COOL or LOW COOL the fan runs continuously at the selected speed until the room temperature reaches 1 °F below the set point.

COOL/VENT Button

Press the COOL/VENT button to turn the cooler media pump on or off. When in the COOL mode, the last set point and AUTO fan speed will be displayed. To change the set point, press the up or down SET TEMP buttons. To change the fan speed, press the FAN button to operate on HIGH, LOW or AUTO. If the media pump was off for 10 minutes, the word “WAIT” will be displayed indicating pre-wetting of the media. Pre-wetting takes 1 minute followed by 30 seconds of HIGH fan, after which the fan returns to the appropriate speed. When in VENT, the fan will start in HIGH. To change to LOW, press the FAN button. Only HIGH and LOW fan speeds are available in VENT mode.

TIMER Button

The timer has a maximum of 24 hours of start or stop delay and is adjustable in 1 hour increments.

To set system STOP delay: Turn the cooler ON and press the TIMER button. The word “STOP” will be displayed along with “10 HRS FROM NOW”. To increase or decrease the delay, use the “+” or “-” HOURS buttons. Operating modes can be changed during the delayed stop time period without affecting the TIMER. Pressing the ON or TIMER buttons will cancel the delayed stop. After the delay stop time period, the system will remain OFF until activated by the user.

To set system START delay: Turn the cooler OFF and press the TIMER button. The word “START” will be displayed along with “10 HRS FROM NOW”. To adjust the start delay, use the “+” or “-” HOURS buttons to increase or decrease the start delay time. Set the desired operating mode and fan function.

Changes can be made at any time. Pressing the ON button will cancel the delay start and turn the cooler ON. Pressing the TIMER button will cancel the delay start and the system will remain OFF. After the delay period, the cooler will turn ON and remain ON until deactivated by the user.

ROOM TEMP Button

Press the ROOM TEMP button to display room temperature. The room temperature will be displayed for 6 seconds. The ROOM TEMP function can be used in any operating mode including system OFF. Note: Due to the variation in accuracy from one thermostat to the next, there will be some variation in the room temperature displayed by different thermostats.

Automatic Pro Clean System

Your cooler is equipped with two LSP-93 “low sump” pumps. The cooler pump supplies water to the media and the drain pump dumps the contents of the sump every 5 hours of media pump operation. The sump automatically fills with fresh water. The drain cycle is controlled automatically by the Pro-Stat and the word “DRAIN” will flash on the display while the drain cycle is active.

DRAIN Button

Pressing the DRAIN Button will activate the drain pump for 1 ½ minutes and cause the timed drain cycle to reset. The word “DRAIN” will flash on the display. The DRAIN cycle can be initiated in any operating mode including system OFF. If the DRAIN cycle is initiated during a prewet cycle, the word “WAIT” will flash on the display, and the DRAIN cycle will start after the prewet cycle is completed. The DRAIN button can be used to drain the cooler at the end of the season by first closing the water supply to the cooler.

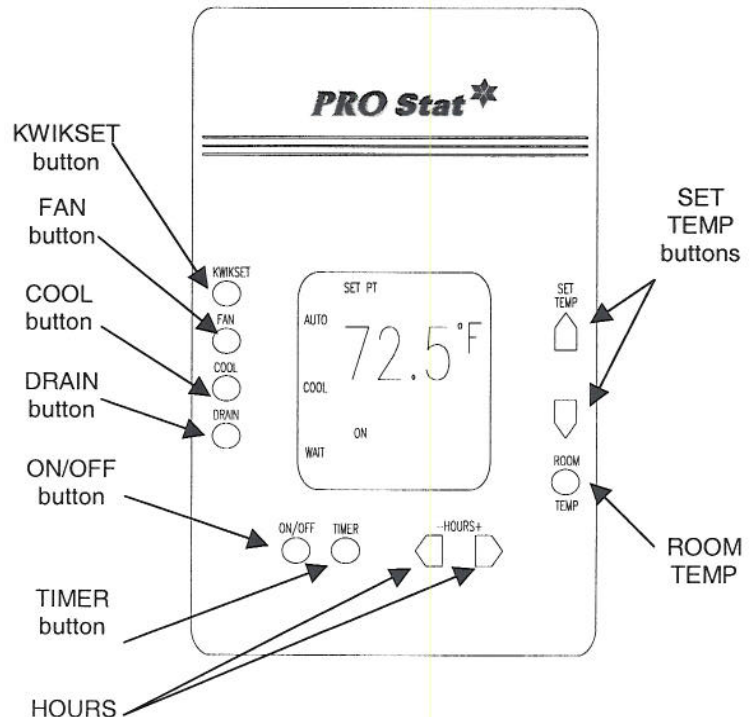

SPECIAL FUNCTIONS

KWIKSET Presets

Press the KWIKSET button to display the DAY or NITE preset or to return to the standard display mode. Pressing the KWIKSET button to either the DAY or NITE preset causes the set point, FAN and COOL settings to assume the values stored in memory. Settings for set point, FAN, and COOL modes are displayed for each preset. The cooler will then operate with the displayed preset settings until the user leaves the KWIKSET mode or enters a different preset.

Change/Save a Preset: Press the KWIKSET button until the desired preset is displayed. To initiate the edit mode, press either COOL, FAN, Up or Down buttons. The edit mode is activated when the DAY or NITE icon is flashing on the display. Choose the new operating mode (COOL or VENT), the new set point, and the new FAN mode (AUTO, HIGH, LOW) with the appropriate buttons. To save the new settings, press the KWIKSET button. The NITE or DAY icon will stop flashing indicating that the new operating modes have been stored in memory.

Save a Preset With Delayed Stop Timer: Press KWIKSET until the desired preset is displayed. Enter the editing mode (press either FAN, COOL, Up or Down buttons). The NITE (or DAY) icon should be flashing. Activate the delay timer by pressing TIMER. Set the desired delay using the "+" or "-" HOURS buttons. Make any other changes to COOL, FAN, or set point as desired. Save the changes by pressing the KWIKSET button. The stop delay is now part of the preset. To remove the stop delay from the preset, enter the editing mode, press the TIMER button to turn off the timer, and save the changes.

Save a Preset With Delayed Start Timer: Press KWIKSET until the desired preset is displayed. Enter the editing mode and make desired changes to set point, FAN, and COOL modes (the NITE or DAY icon will be flashing). Next, press the ON/OFF button. The control will automatically set the system OFF and start delay timer when the edit mode is active. Adjust the start delay time using the "+" and "-" HOURS buttons. Change any of the operating modes (COOL, FAN, and set point) as desired. Press the KWIKSET button to save the preset with start delay. To remove the start delay from the preset, Press KWIKSET until the desired preset is displayed, initiate editing, and press either the ON/OFF or the TIMER button. The control will automatically be set to ON. Press the KWIKSET button to save the preset without the start delay.

Advanced Delay Timer

If a preset is saved with a delayed stop, it is possible to set a delayed start for this preset (this feature only works for presets with delayed stop). Press the KWIKSET button until the desired preset (with stop delay) is displayed. Press the ON/OFF button to turn the system OFF. Press the TIMER button to activate the start delay and use the "+" and "-" HOURS buttons to adjust the start delay. The start delay will count down until the preset is activated and then the stop delay will count down until the system is turned OFF. Changes to the operating modes made while the advanced start delay is active will not affect the preset, but will be temporarily saved and will be displayed when the system is turned ON after the preset is finished running.

Change Scale

To change the temperature scale, press COOL to view set point. Press and hold the SET TEMP up and down buttons and release when the displayed temperature changes from °F to °C or vice versa. The new temperature scale will remain active until an ERASE command is issued. Scale change can only occur in the COOL mode.

Erase Function

The ERASE function will restore all settings to the factory default values. First, turn the system ON and hold the ON/OFF button down until ERASE is complete. Wait for 1 second, and then hold the SET TEMP up and down buttons down. After about 3 seconds, the number "0.9" will be displayed and will begin to count down to "0.0". When the set point of 72.5 °F is displayed, the ERASE function is complete.

Program Differential Value

The differential value is the difference between the turn off temp and the turn on temp. To change the differential, press and hold the ROOM TEMP and SET TEMP down buttons until the display changes to the program display. Press the SET TEMP up button to increase the differential and the down button to decrease the differential. Press the ROOM TEMP button to save the new differential. The new differential will remain active until the ERASE function is executed.

Reset

To perform a control reset, press and hold the timer buttons (TIMER and both HOURS buttons) until the display goes blank. Release the buttons and the display will return to normal. NOTE: If the operating mode was changed or if a delay timer was set after the last power up or power failure, the changes will not be recalled. Only the last saved data will be restored. KWIKSET presets and differential settings will remain intact. In the event of power failure, delay timer settings will be maintained for a minimum of 8 hours and up to 15 hours. At the end of the 15 hours, the timers will no longer be updated. Any remaining time left in the delay will continue after power is restored.

AUTOMATIC PRO CLEANING SYSTEM

FULL AUTOMATIC: Fresh water for your evaporative cooler every 5 hours of operation!

How it works...

The Pro Cleaning System (PCS) will automatically cycle every 5 hours of cooler pump operation to empty the water reservoir within 1 1/2 minutes. This cycle allows the cooler to re-fill with fresh water. At no time is cooling capability interrupted.

The benefits of fresh water replacement on a regular basis include reduction of mineral scale build-up, bacterial growth control, reduced water consumption (bleed-off is eliminated), easier maintenance and longer pad life WITHOUT the use of harsh chemical additives or cleaners.

The pumps used in this cooler can pump water down to a very low level. It is important to replace them, if needed, with the same pump LSP93 made by Phoenix Manufacturing, Inc.

To install the PRO Cleaning System....

1. Connect one end of the water tube to the discharge outlet of the PCS and firmly insert the other end (with drain adapter fitting) into the cooler overflow standpipe. Avoid "kinking" the water tube. Make sure PCS is plugged into receptacle marked "DRAIN PUMP".
2. You must provide a 3/4" or larger garden hose or PVC pipe drain beneath the cooler standpipe to take the water away to an appropriate drain site.
Maintenance consists of cleaning the PCS inlet screen at the beginning of each cooler season.

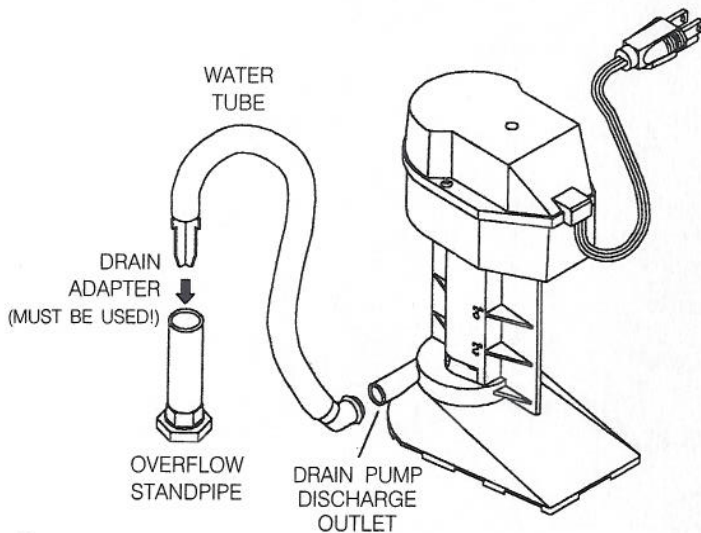

LIMPIADOR AUTOMATICO PRO DE POTENCIA

COMPLETAMENTE AUTOMATICO: Agua fresca para su cooler cada 5 horas de operacion!

COMO TRABAJA...

Una vez instalado, el sistema limpiador automatico (PCS) funciona automaticamente cada 5 horas de operacion de la bomba del enfriador para vaciar el agua del deposito en 1 1/2 minutos. Este ciclo permite al enfriador llenarse con agua fresca. La accion enfriadora no es interrumpida.

Los beneficios de remplazar regularmente con agua fresca incluye la reduccion de la acumulacion de escama mineral, controla el crecimiento de bacteria (la sangria es eliminada), facil mantenimiento y larga vida del filtro - SIN el uso de asperos aditivos quimicos o limpiadores.

Para resultados optimos, use este producto con las bombas LSP93 o LSP94 (bombas a bajo nivel).

Las bombas usadas en este enfriador pueden bombear el agua hasta muy bajo nivel. Es importante remplazarlas, si en necesario, con el mismo modelo LSP93 hechas por Phoenix Manufacturing, Inc.

Para instalar el Sistema Pro de Limpieza....

1. Conecte un lado de la manguera de agua a la descarga de la salida del limpiador automatico de potencia (PCS) y firmemente inserte la otra punta (con el adaptador de desagüe) en el tubo rebosadero del enfriador. Evite "Doblar" la manguera de agua.
Asegurese que el PCS está enchufado en el receptaculo marcado "Drain Pump".
2. Usted tiene que proveer una manguera de jardin de 3/4 de pulgada o un tubo de PVC debajo de el rebosadero del enfriador para llevar el agua a un lugar apropiado para drenaje.

El mantenimiento consiste en limpiar el filtro de la unidad al empiezo de cada temporada de uso.

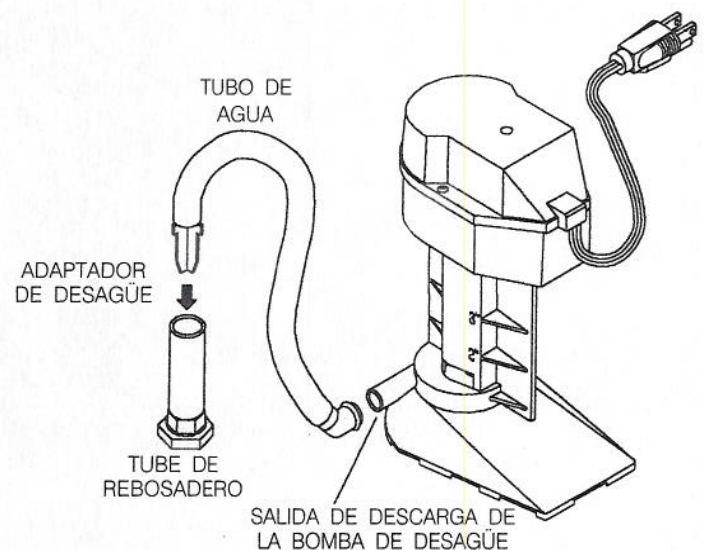

Troubleshooting

Should an obvious problem occur with your cooler consult the following table. If you cannot correct the problem, contact a qualified service representative.

PROBLEM	PROBABLE CAUSE	CORRECTIVE ACTION
Water Overflow	Float valve out of adjustment	Adjust float to 2" water depth
	Float movement obstructed	Free float from obstruction
	Float valve defective	Replace float assembly
Blower will not operate	Electrical power disconnected	Check power receptacle and cord
	Motor defective	Replace motor
	Control / thermostat defective	Replace control or thermostat
	Blower belt broken	Replace belt
Fuse blown or circuit breaker tripped	Wiring faulty or wired incorrectly	Repair or replace defective wiring
	Motor faulty	Replace motor
	Water pump faulty	Replace water pump
Dry Pads	Water level incorrect	Adjust float to 2" water depth
	Pump intake clogged	Remove obstruction
	Water pump faulty	Replace water pump
	Clogged water line	Locate and free obstruction
	Distributor tube clogged	Clear debris from tube
	Control / thermostat faulty	Replace control / or thermostat
	Wiring faulty	Repair or replace defective wiring
Cooler noisy	Blower rubbing on housing	Reposition wheel
	Motor sheave loose	Tighten set screws
	Blower set screws loose	Tighten set screws
Inadequate air flow	Pad plugged	Clean or replace media
	Belt loose	Adjust belt tension
	Insufficient exhaust vent area	Open windows or doors

Trazando Fallas

En caso de alguna falla en su enfriador consulte la tabla 2, "Trazando fallas." Esta tabla es una guía para los problemas mas obvios. Si usted no puede corregir el problema pongase en contacto con un competente representante de servicio.

PROBLEMA	PROBABLE CAUSA	ACCION CORRECTIVA
Derrame De Agua	Valvula fuera de ajuste	Ajuste Valvula a 2 pulgadas de profundidad de agua
	Flotador atorado	Libere el flotador
	Valvula defectuosa	Remplase la
La Turbina No Funciona	Electricidad desconectada	Revise corriente, receptaculo y cordon
	Motor defectuoso	Remplase el motor
	Control o termostato defectuoso	Remplase el interruptor o termostato
	Banda rota	Remplase la
Fusible Quemado Cortacircuito se apaga	Fallas en el alambrado o alambrado incorrectamente	Repare o remplase los alambres defectuosos
	Motor defectuoso	Remplase el motor
	Bomba defectuosa	Remplase Bomba
Filtros Secos	Nivel de agua incorrecto	Ajuste valvula a 2 pulgadas de profundidad
	Entrada de agua en la bomba obstruida	Limpie la entrada de agua
	Bomba defectuosa	Remplase bomba
	Linea de agua tapada	Localice y libere la obstruccion
	Tubo De distribuidor tapado	Localize y limpie la obstruccion en el tubo
	Control / termostato defectuoso	Remplase control o termostato
	Alambre defectuoso	Repare o remplase los alambres defectuosos
Enfriador Ruidoso	Turbina roza con la caja de esta	Realinie turbina
	Polea motriz ruidosa	Apriete los tornillos opresores
	Tornillos de turbina flojos	Apriete los tornillos opresores
Flujo De Aire Inadecuado	Filtro tapado	Limpie O remplase filtro
	Banda floja	Ajuste la tension de esta
	Insuficiente escape de aire en el area ventilada	Abra ventanas o puertas