

This Owner's Manual is provided and hosted by [Appliance Factory Parts](http://ApplianceFactoryParts.com).

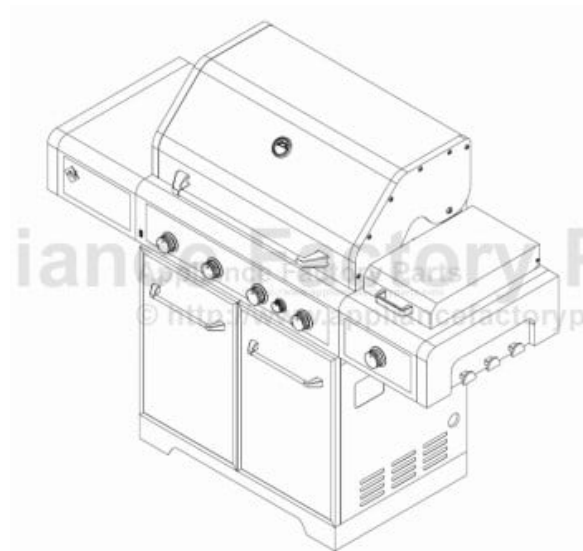

Members Mark - Old 720-0691A - Old Owner's Manual

[Shop genuine replacement parts for Members Mark -
Old 720-0691A - Old](#)



[Find Your Members Mark - Old Grill Parts - Select From 12 Models](#)

----- Manual continues below -----



MEMBER'S MARK®

Assembly & Operating Instructions

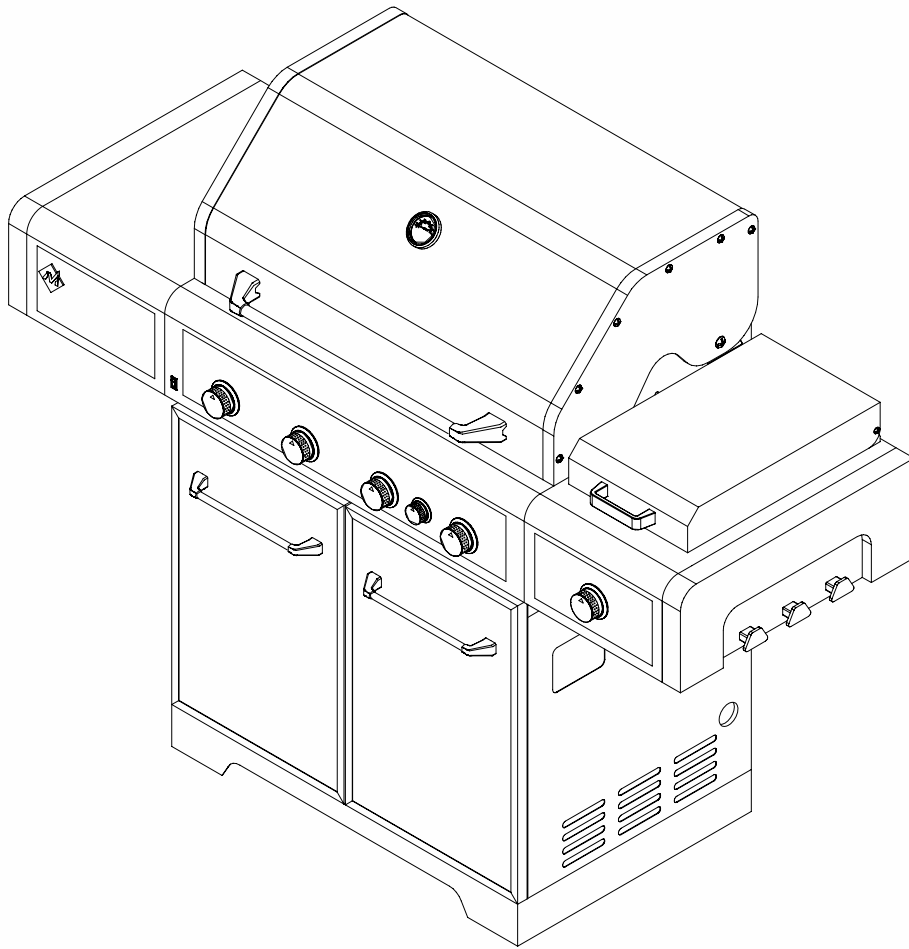

19000272A0

This instructions manual contains important information necessary for the proper assembly and safe use of the appliance. Read and follow all warnings and instructions before assembling and using the appliance. Keep this manual for future reference.

Model No: 720/730-0691A

FOR OUTDOOR USE ONLY

Safety Instruction	2-5	Trouble Shooting	23-24
Parts Check list.	6	Exploded View	25
Assembly Instruction	7-14	Part List	26-27
Gas Hook –Up	15	Ordering Parts	28
Installer Final Check List.	16	Grill Hints	28
Leak Testing	16-17	Grill Cooking Chart	28-29
Operating Instruction	18	Grill Recipe Suggestion	30-31
Grill Lighting Instruction	18-19	Limited Warranty	32
Lighting Instruction.	19-20	Natural Gas Conversion	33-41
Grill Light	21		
Care and Maintenance	22		

Safety Instruction

 **DANGER**

If you smell gas:

- 1. Shut off gas to the appliance.**
- 2. Extinguish any open flame.**
- 3. Open lid.**
- 4. If odor continues, keep away from the appliance and immediately call your gas supplier or your fire department.**

 **WARNING**

- 1. Do not store or use gasoline or other flammable liquids or vapors in the vicinity of this or any other appliance.**
- 2. An LP cylinder not connected for use shall not be stored in the vicinity of this or any other appliance.**

 Failure to comply with these instructions could result in a fire or explosion that could cause serious bodily injury, death, or property damage.

 Combustion by products produced when using this product contain chemicals known to the States of California to cause cancer, birth defects, or other reproductive harm

 Your grill will be very hot. Never lean over the cooking area while using your grill. Do not touch cooking surfaces, grill housing, lid or any other grill parts while the grill is in operation, or until the gas grill has cooled down after use.



WARNING

ELECTRICAL GROUNDING INSTRUCTIONS This appliance (light and transformer) is equipped with a plug and should be plugged directly into a properly grounded receptacle. When installed, must be electrically grounded in accordance with local codes or in the absence of local codes, with the National Electrical Code, ANSI/NFPA 70 or the Canadian Electrical Code, CSA C22.1 DO NOT cut or remove the grounding prong from this plug.

1. To protect against electric shock, do not immerse cord or plugs in water or other liquid.
2. Unplug from the outlet when not in use and before cleaning. Allow to cool before putting on or taking off parts.
3. Do not operate any outdoor cooking gas appliance with a damaged cord, plug, or after the appliance malfunctions or has been damaged in any manner. Contact the manufacturer for repair.
4. Do not let the cord hang over the edge of a table or hot surface.
5. Do not use an outdoor cooking gas appliance for purposes other than intended.
6. When connecting, first connect plug to the outdoor cooking gas appliance then plug appliance into the outlet.
7. Use only a Ground Fault Interrupt (GFI) protected circuit with this outdoor cooking gas appliance.
8. Never remove the grounding plug or use with an adapter of 2 prongs.
9. Use only extension cords with a 3 prong grounding plug, rated for the power of the equipments, and approved for outdoor use with a W-A marking.



WARNING

Do not try lighting this appliance without reading the "LIGHTING INSTRUCTIONS" section of this manual.

TESTED IN ACCORDANCE WITH ANS Z21.58a CSA 1.6a-2008 STANDARD FOR OUTDOOR COOKING GAS APPLIANCE. THIS GRILL IS FOR OUTDOOR USE ONLY.

Grill Installation Codes

Check your local building codes for the proper method of installation. In the absence of local codes, this unit should be installed in accordance with the National Fuel Gas Code, ANSI Z223.1/NFPA 54, Storage and Handling of Liquefied Petroleum Gases, ANSI/NFPA B149.2 or CSA B149.1 Natural Gas and Propane Installation Code, and the National Electrical Code, ANSI/NFPA 70.

Correct LP Gas Tank Use

LP gas grill models are designed for use with a standard 20 lb. Liquid Propane Gas tank, not included with grill. **Never** connect your gas grill to an LP gas tank that exceeds this capacity.

If an external electrical source is utilized: The outdoor cooking gas appliance, when installed, must be electrically grounded in accordance with local codes or, in the absence of local codes, with the National Electrical Code, ANSI/NFPA 70, or the Canadian Electrical Code, CSA C22.1.

WARNING

Keep any electrical supply cord and the fuel supply hose away from any heated surfaces.

NOTE: The normal flow of gas through the regulator and hose assembly can create a humming noise. A low volume of noise is perfectly normal and will not interfere with operation of the grill. If humming noise is loud and excessive you may need to purge air from the gas line or reset the regulator excess gas flow device. This purging procedure should be done every time a new LP gas tank is connected to your grill.

CAUTION: Beware of Flashback

CAUTION: Spiders and small insects occasionally spin webs or make nest in the grill burner tubes during transit and warehousing. These webs can lead to gas flow obstruction, which could result in a fire in and around burner tubes. This type of fire is known as "FLASH-BACK" and can cause serious damage to your grill and create an unsafe operating condition for the user.

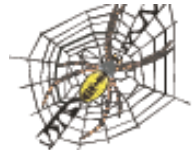

Although an obstructed burner tube is not the only cause of "FLASH-BACK", it is the most common cause.

To reduce the chance of "FLASH-BACK", you must clean the burner tubes before assembling your grill, and at least once a month in late summer or early fall when spiders are most active. Also perform this burner tube cleaning procedure if your grill has not been used for an extended period of time. A clogged tube can lead to a fire beneath the grill.

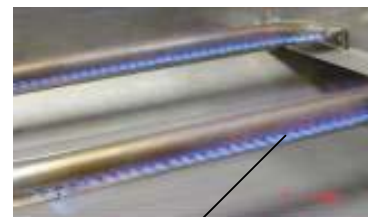

Visually check the burner flames prior to each use. The flames should look like this picture. If they do not, refer to the burner main tenancy part of this manual.

LP-Gas Supply System



Always keep the LP cylinder at 90° (upright) orientation to provide vapor withdraw.

- If the information is not followed exactly, a fire resulting in death or serious injury could occur.
- A 20lb tank of approximately # 1/4 inches in diameter by 18-1/4 inches high is the maximum size LP gas tank to use.
- This safety feature prevents the tank from being overfilled, which can cause malfunction of the LP gas tank, regulator and/or grill.
- The LP gas supply cylinder to be used must be constructed and marked in accordance with the specifications for LP – Gas cylinder of the U.S. Department of Transportation (DOT) or the National Standard of Canada ,CAN/CSA –B339, Cylinders, Spheres and Tubes for Transportation of Dangerous Goods and Commission .
- The LP gas tank must have a shutoff valve terminating in an LP valve outlet that is compatible with a Type 1. LP gas supply cylinder must have a shut off valve terminating in a valve outlet specified for connection type QCC1 in the standard for compressed gas cylinder valve outlet and inlet connection ANSI/CGA-V-1 as applicable. LP gas supply cylinder must be fitted with an Overfill Protection Device (O.P.D) The LP gas tank must also have a safety relief device that has a direct connection with the vapor space of the tank.
- The tank supply system must be arranged for vapor withdrawal.
- The LP gas tank used must have a collar to protect the tank valve.
- Place dust cap on cylinder valve outlet whenever the cylinder is not in use. Only install the type of dust cap on the cylinder valve outlet that is provided with the cylinder valve. Other types of cap or plugs may result in leakage of propane.
- **Never** connect an unregulated LP gas tank to your gas grill.
- This outdoor cooking gas appliance is equipped with a high capacity hose/regulator assembly for connection to a standard 20lb. Liquid propane cylinder.
- Have your LP gas tank filled by a reputable propane gas dealer and visually inspected and re-qualified at each filling.
- Do not store a spare LP gas cylinder under or near this appliance.
- Never fill the cylinder beyond 80 percent full.
- Always keep LP gas tanks in an upright position.
- Do not store or use gasoline or other flammable vapors and liquids in the vicinity of this or any other appliance.
- Storage of an outdoor cooking gas appliance indoors is permissible only if the cylinder is disconnected and removed from the outdoor cooking gas appliance.
- When your gas grill is not in use the gas must be turned off at LP gas tank.

PROPER PLACEMENT AND CLEARANCE OF GRILL

- Never use your gas grill in a garage, porch, shed, breezeway or any other enclosed area. Your gas grill is to be used outdoors only.
Do Not install this unit into combustible enclosures. Minimum clearance from sides and back of unit to combustible construction, 24 inches (61cm) from sides and 24 inches (61cm) from back.
- **DO NOT** use this appliance under overhead combustible surfaces. This outdoors cooking gas appliance is not intend to be installed in or on recreational vehicles and/or boats.

- The gas must be turned off at the supply cylinder when the outdoor cooking gas appliance is not in use.
- LP gas tank must be stored outdoors in a well-ventilated area and out of reach of children. Disconnected LP gas tanks must not be stored in a building, garage or any other enclosed area.
- Do Not obstruct the flow of ventilation air around the gas grill housing. Only use the regulator and the hose assembly supplied with your gas grill. Replacement regulators and hose assemblies must be those specified in this manual.
- The regulator and hose assembly must be inspected before each use of the grill. If there is excessive abrasion or wear or if the hose is cut, it must be replaced prior to the grill being put into operation. The replacement hose assembly shall be that specified by the manufacturer.
- Pressure regulator and hose assembly supplied with the outdoor cooking gas appliance must be used. Never substitute other types of regulator. Contact customer service for manufacturer specified replacement parts.
- This outdoor cooking gas appliance is equipped with a pressure regulator comply with the standard for Pressure Regulating Valves for LP Gas ANSI/ UL 144.
- Do not use briquettes of any kind in the grill.
- The grill is designed for optimum performance without the use of briquettes. Do not place briquettes on the radiant as this will block off the area for the grill burners to vent. Adding briquettes can damage ignition components and knobs, and void the warranty.
- Keep the back and side cart free and clear from debris. Keep any electrical supply cord, or the rotisserie motor cord away from the heated areas of the grill.
- Never use the grill in extremely windy conditions. If located in a consistently windy area (oceanfront, mountaintop, etc.) a windbreak will be required. Always adhere to the specified clearance.
- Never use a dented or rusty propane tank.
- Keep any electrical supply cord and the fuel supply hose away from any heated surface.
- While lighting, keep your face and hands as far away from the grill as possible.
- Burner adjustment should only be performed after the burner have cooled.

⚠ WARNING

Your grill will get very hot. Never lean over the cooking area while using your grill. Do not touch cooking surfaces, grill housing, lid or any other grill parts while the grill is in operation, or until the gas grill has cooled down after use.

Failure to comply with these instructions may result in serious bodily injury.

CAUTION: TO ENSURE CONTINUED PROTECTION AGAINST RISK OF ELECTRIC SHOCK, CONNECT TO PROPERLY GROUNDED OUTLETS ONLY, TO REDUCE THE RISK OF ELECTRIC SHOCK, KEEP EXTENSION CORD CONNECTION DRY AND OFF THE GROUND.

INSECT WARNING

Spiders and insects can nest in the burners of this and any other grill, and cause the gas to flow improperly. This is a very dangerous condition, which can cause a fire to occur behind and beneath the valve panel, thereby damaging the grill and making it unsafe to operate. Inspect the grill at least twice a year.



WARNING

Keep a spray bottle of soapy water near the gas supply valve and check the connections before each use.

DO NOT USE ALUMINUM FOIL TO LINE THE GRILL RACKS OR GRILL BOTTOM.

This can severely upset combustion airflow or trap excessive heat in the control area.

DO NOT LEAVE THE GRILL UNATTENDED WHILE COOKING.

SAFETY PRACTICES TO AVOID PERSONAL INJURY

When properly cared for your grill will provide safe, reliable service for many years. However, extreme care must be used as the grill produces intense heat that can increase accident potential. When using this appliance basic safety practices must be followed, including the following: Do not repair or replace any part of the grill unless specifically recommended in this manual. All other service should be referred to a qualified technician. This grill is not intended to be installed in or on recreational vehicles or boats.

Children should not be left alone or unattended in an area where the grill is being used. Do not allow them to sit, stand or play in or around the grill at any time. Do not store items of interest to children around or below the grill. Do not permit clothing, pot holders or other flammable materials to come in contact with or too close to any grate, burner or hot surface until it has cooled. The fabric could ignite and cause personal injury.

For personal safety, wear proper apparel. Loose fitting garments or sleeves should never be worn while using this appliance. Some synthetic fabrics are highly flammable and should not be worn while cooking.

Only certain types of glass, heat-proof glass ceramic, earthenware, or other glazed utensils are suitable for grill use. These materials may break with sudden temperature changes. Use only on low or medium heat settings in accordance with the manufacturer's guidelines.

Do not heat unopened food containers. A build-up of pressure may cause the containers to burst.

Use a covered hand when opening the grill lid. Never lean over an open grill.

When lighting a burner, pay close attention to what you are doing. Make certain you are aware of which burner you are lighting, so your body and clothing remain clear of open flames.

When using the grill, do not touch the grill rack, burner grate or immediate surroundings as these areas become extremely hot and could cause burns. Use only dry potholders. Moist or damp potholders on hot surfaces may cause steam burns. Do not use a towel or bulky cloth in place or potholders. Do not allow potholders to touch hot portions of the grill rack.

Grease is flammable. Let hot grease cool before attempting to handle it. Do not allow grease deposits to collect in the grease tray at the bottom of the grill's firebox. Clean the grease tray often

Do not use aluminum foil to line the grill racks or grill bottom. This can severely upset combustion air flow or trap excessive heat in the control area.

For proper lighting and performance of the burners keep the burner ports clean. It is necessary to clean them periodically for optimum performance. The burners will only operate in one position and must be mounted correctly for safe operation.

Clean the grill with caution. To avoid steam burns, do not use a wet sponge or cloth to clean the grill while it is hot. Some cleaners produce toxic fumes or can ignite if applied to a hot surface.

Turn off grill controls and make certain the grill is cool before using any type of aerosol cleaner on or around the grill. The chemical that produces the spraying action could, in the presence of heat, ignite or cause metal parts to corrode.

Do not use the grill to cook excessively fatty meats or other products which promote flare – ups. Do not operate the grill under unprotected combustible constructions. Use only in well ventilated areas. Do not use in buildings, garages, sheds, breezeways or other such enclosed areas.

Keep the area surrounding the grill free from combustible materials including, fluids, trash, and vapors such as gasoline or charcoal lighter fluid. Do not obstruct the flow of combustion and ventilation air.





WARNING

This outdoor cooking gas appliance is not intended to be installed in or on boats. And other recreational vehicles.

Parts Check List

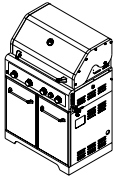
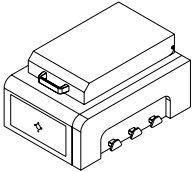
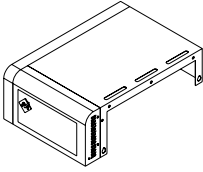
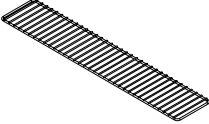
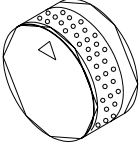
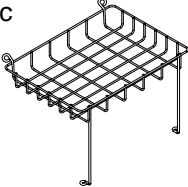
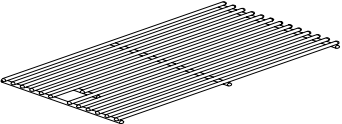
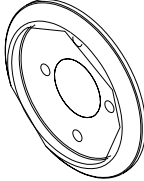
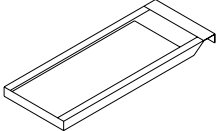
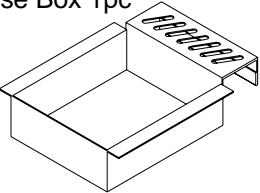
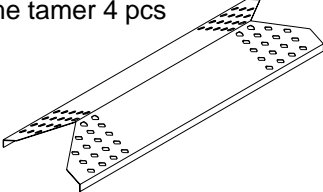
Screws used to attach the parts are already pre-placed on the parts or grill body. Loosen the screws before you install the part.

<p>Grill Body 1 pc</p> 	<p>Side Burner Bowl 1 pc</p> 	<p>Side Shelf 1 pc</p> 
<p>Warming Rack 1 pc</p> 	<p>Control Knob 1pc</p> 	<p>Wire shelf 1pc</p> 
<p>Cooking grid 3 pcs</p> 	<p>Bezel 1pc</p> 	<p>Side Burner Grease Box 1pc</p> 
<p>Grease Box 1pc</p> 	<p>Flame tamer 4 pcs</p> 	<p>Battery 1pc</p> 
<p>Allen Wrench 1pc</p> 		

REQUIRED TOOLS & INSTALLATION EXAMPLES (screws have been attached on side burner , side panel or corresponding parts)

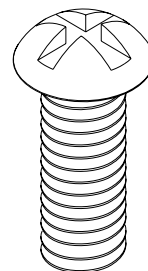

Tighten all screws on the grill as some screws may have loosened during transit

Step 1: Side Burner Bowl Assembly

1a). Loosen the bottom 2 screws that are located on the right side panel of the grill. Do not remove completely. See fig.1

1b). Remove the bottom screw that is located on the right side control panel. See fig.1

Fig.1

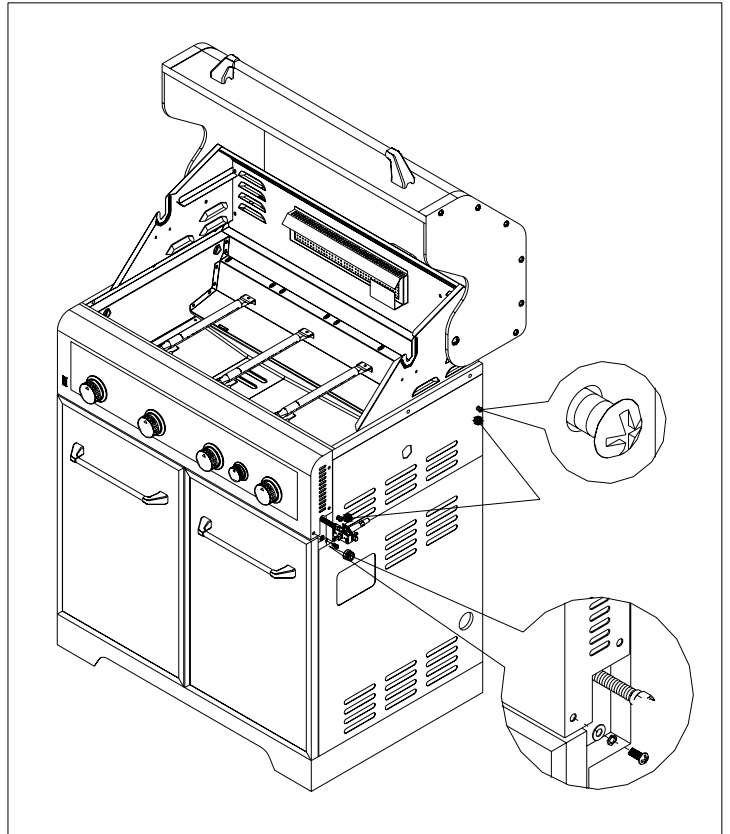

1c). Remove the 3 screws along the top edge of the side burner bowl. See Fig.2

Fig.2

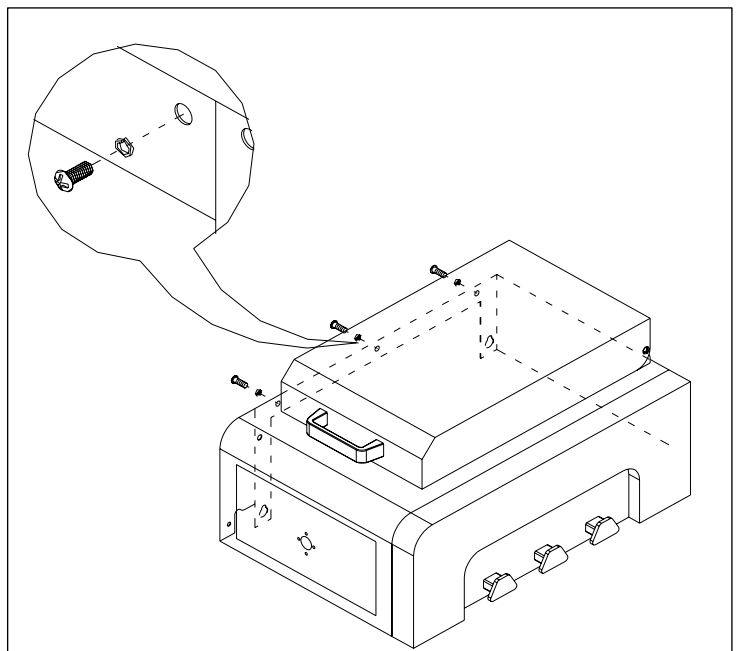

1d). Align the bottom key holes on side burner bowl with 2 loosened screws on right side panel. Attach the side burner bowl to the cart with the two loosened screws on the side panel. See Fig.3

Tip: This step is meant to help with the installation but do not depend solely on the two screws to hold the weight of the side burner shelf.

Fig.3

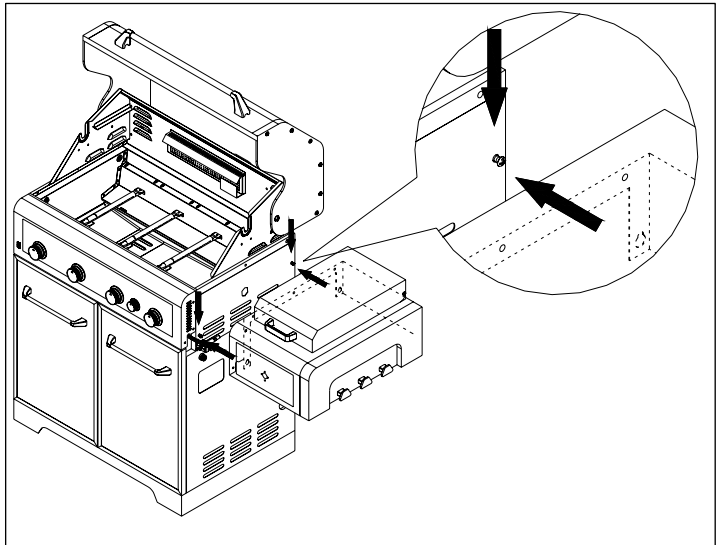

1e). With the three screws removed in Step 1c) insert them from inside the fire box into the side burner bowl. Tighten screws from inside the fire box. See Fig.4

1f). Tighten the two screws loosened in step 1a). See Fig.4

1g). Attach the side burner control panel to the main control panel by tightening the screw removed in step 1b) from underneath the side burner bowl. Screw passes through the side burner control panel to the main control panel. See Fig.4

Fig.4

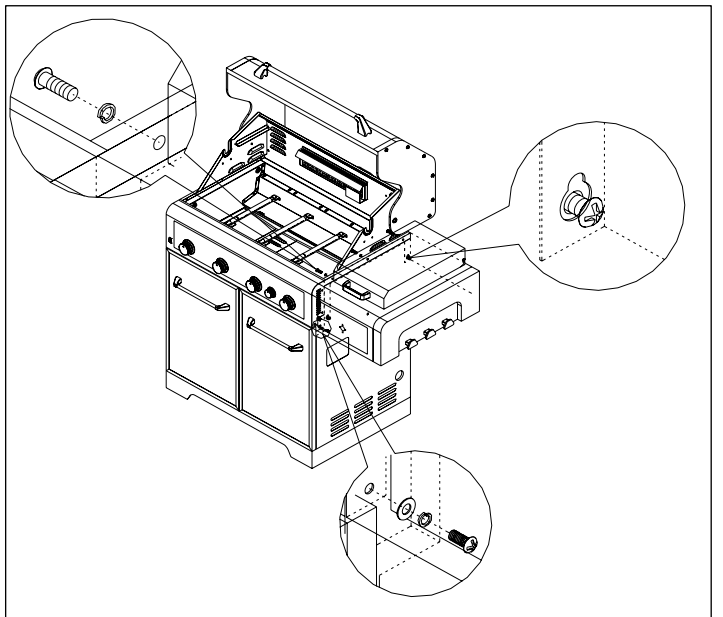

Step 2: Side Shelf Assembly

2a). Loosen the bottom 2 screws that are located on the left side panel of the grill. Do not remove completely. See fig.5

2b). Remove the bottom screw that is located on the left side of control panel. See fig.5

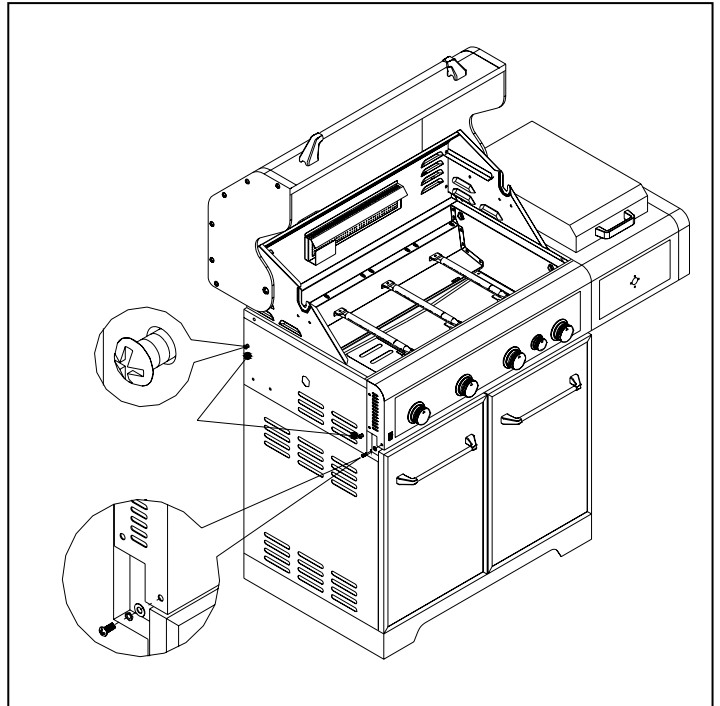
Fig.5**Fig.6**

2c). Remove the 3 screws along the top edge of the side shelf. See Fig.6

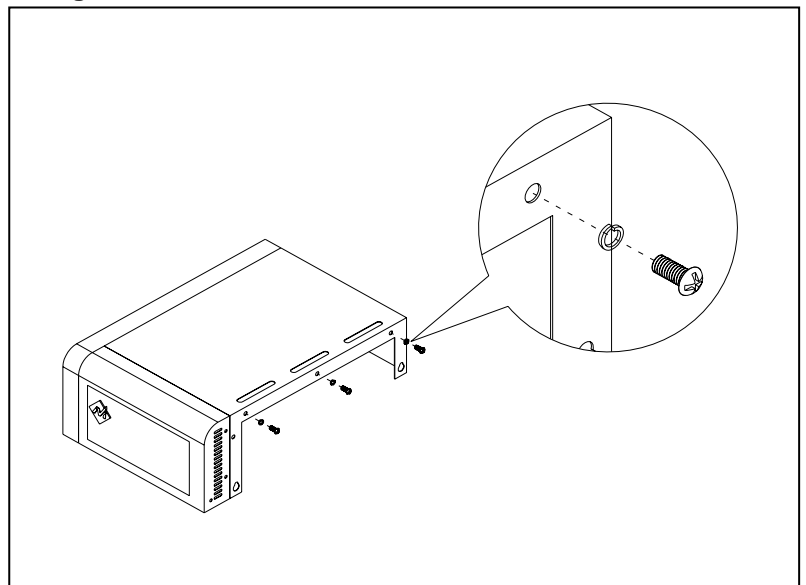

Fig.7

2d). Align the bottom key holes on side shelf with 2 loosened screws on side panel. Attach the side shelf to the cart with the two loosened screws on the side panel. Hook the side shelf into the two screws. See Fig. 7

Tip: This step is meant to help with the installation but do not depend solely on the two screws to hold the weight of the side shelf.

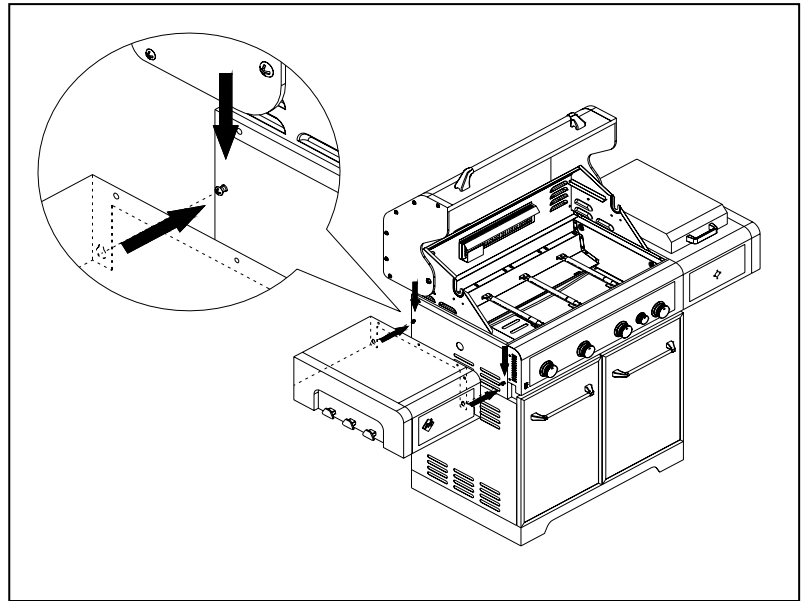
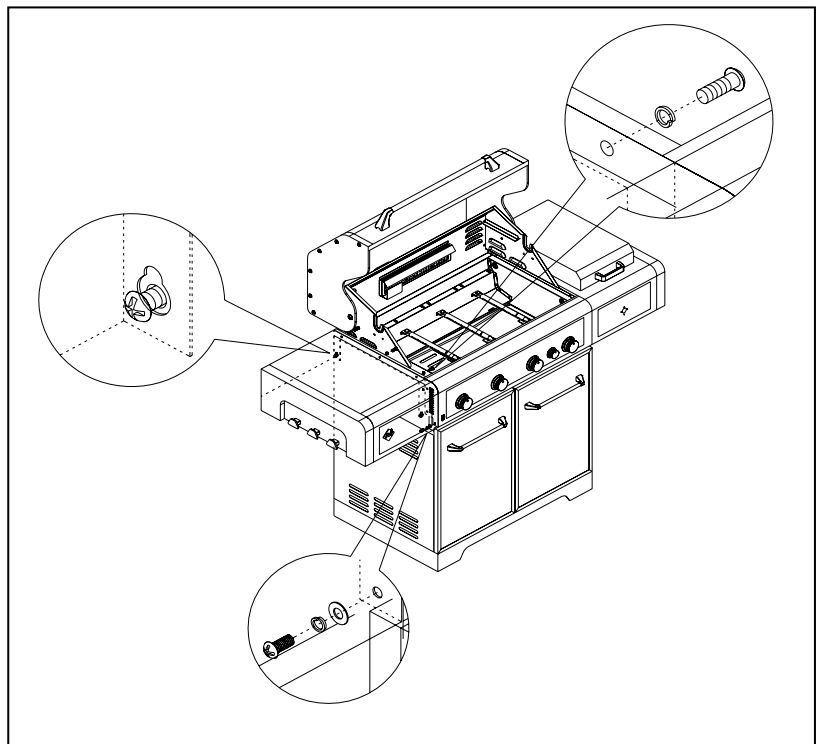

Fig.8

2e). With the three screws removed in Step 2c) insert them from inside the fire box through the side shelf. Tighten screws from inside the fire box. See Fig. 8

2f). Tighten the two screws loosened in step 2a) See Fig. 8

2g). Attach the side burner control panel to the main control panel by tightening the screw removed in step 2b) from underneath the side shelf. Screws pass through the side shelf control panel to the main control panel. See Fig. 8



Step 3: Side Burner Valve Assembly

3a). Loosen the "C" bracket on the burner tube located on the underside of the side shelf bowl by removing the screw holding it in place. Turn the "C" bracket so the opening of the side burner tube is exposed.

3b). Remove the 2 screws that are pre-attached to the valve. Then place the bezel on the side burner control panel, from underneath, insert the side burner valve into the side burner control panel and bezel. Then align the valve through the side burner panel opening, making sure the orifice end is aligned in the burner opening. See Fig. 9

3c). From the front of the side burner control panel, put the two valve screws through the knob bezel, control panel and secure to valve. See Fig. 9

3d). Return to the underside of the side burner and turn the "C" bracket to close the gap in the front opening of the side burner tube. Tighten screw to secure. See Fig. 10

Step 4: Connecting Ignition Wires

Insert the side burner ignition wire to the ignite module located on the right side panel inside the cart. See Fig. 11

Fig.9

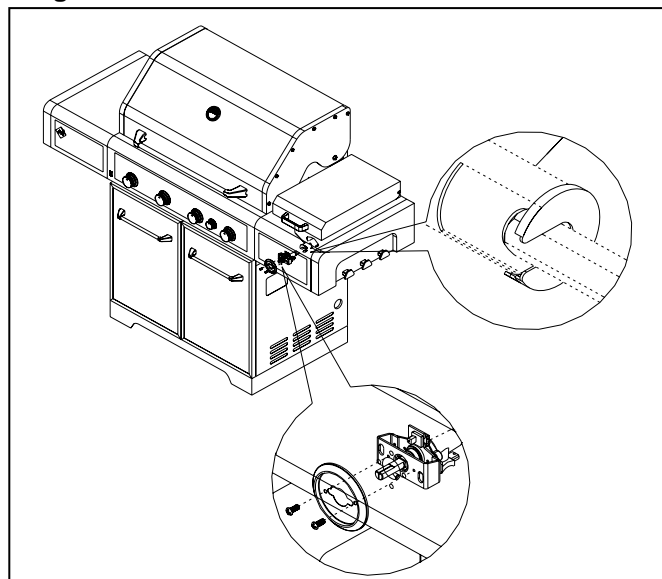

Fig.10

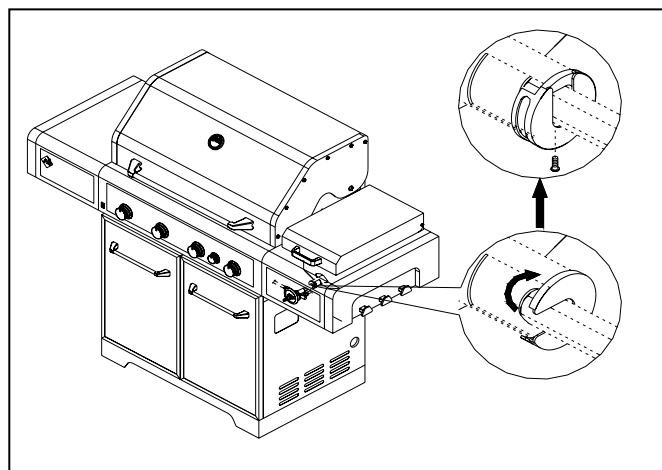
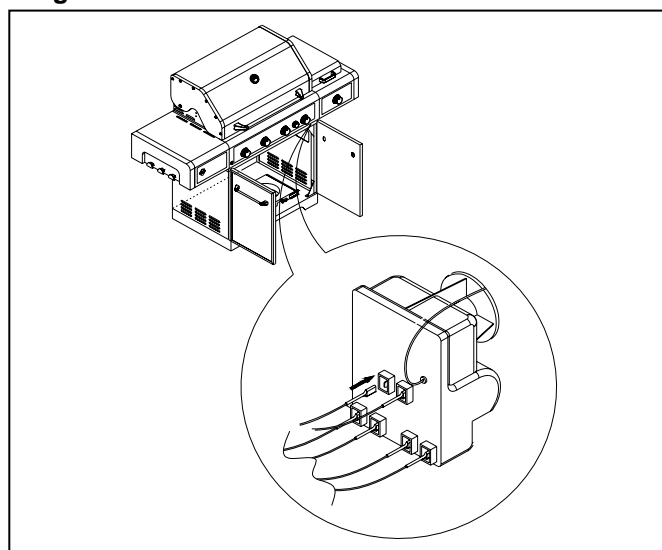

Fig.11



Step 5: Side Burner Knob Assembly

5a). Locate the small opening on the underside of the knob, behind the rubber grip and peel the rubber grip back carefully.

5b). Insert the Allen wrench into the hole and into the set screw, positioned for tightening.

5c). Insert valve stem into knob and tighten the set screw. See Fig. 12

Fig. 12

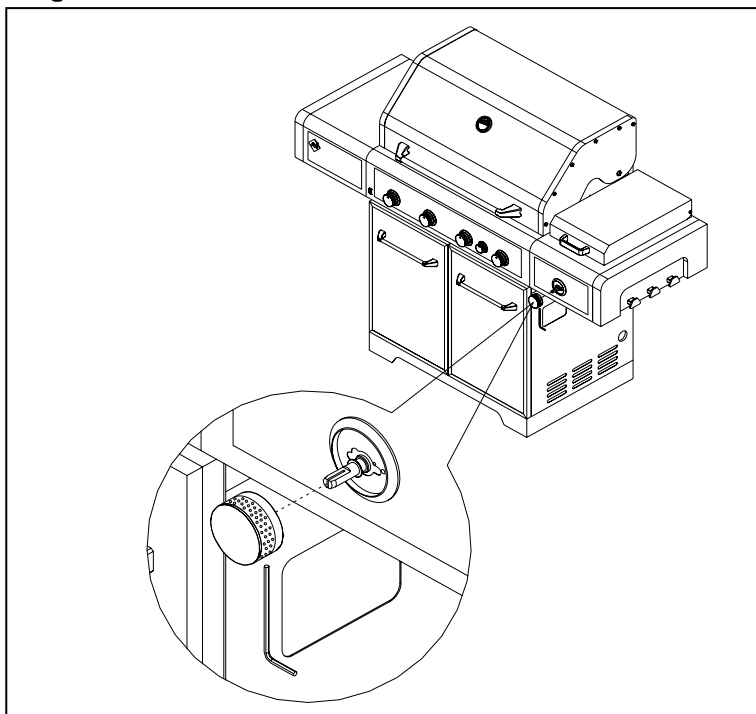

Step 6: Wire Shelf Assembly

6a). Remove the 2 screws on the left side panel and 2 screws from bottom panel that are pre-attached on the cart.

6b). Attach the wire shelf with 2 leg on the bottom panel, tighten the screw, then assemble another 2 screws on left side panel. See Fig. 13

Fig. 13

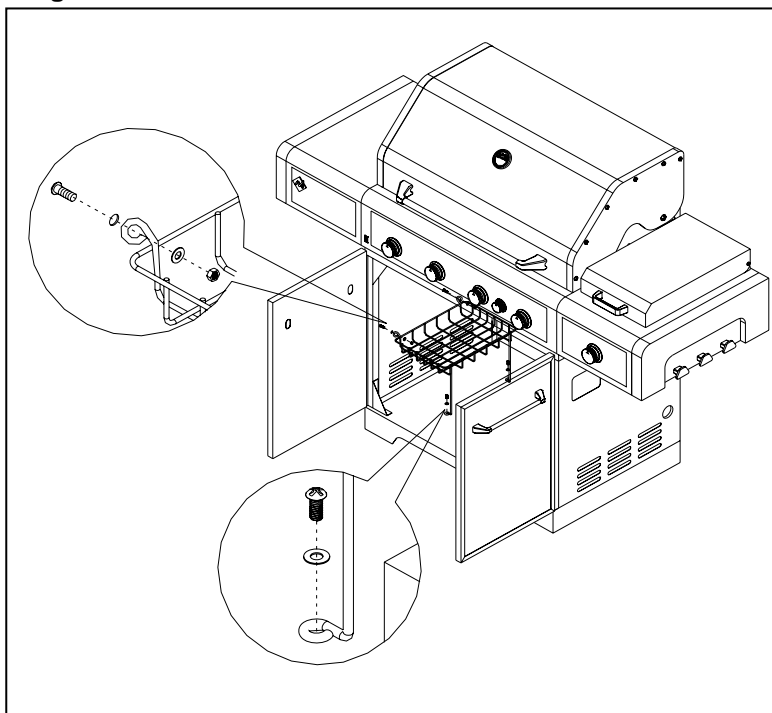

Step 7: Battery Assembly

Unscrew the electronic igniter button and place the battery into the housing with positive terminal (+) facing outward. Replace the ignition button after the battery has been installed. See Fig. 14

Fig. 14

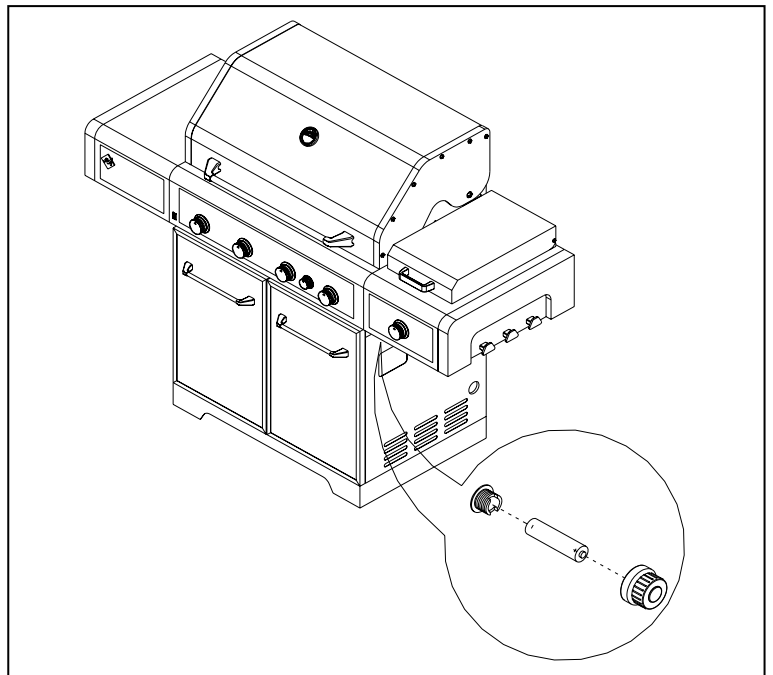

Step 8: Grease Box Assembly

Install the grease box from the rear of the grill. See Fig. 15

Fig. 15

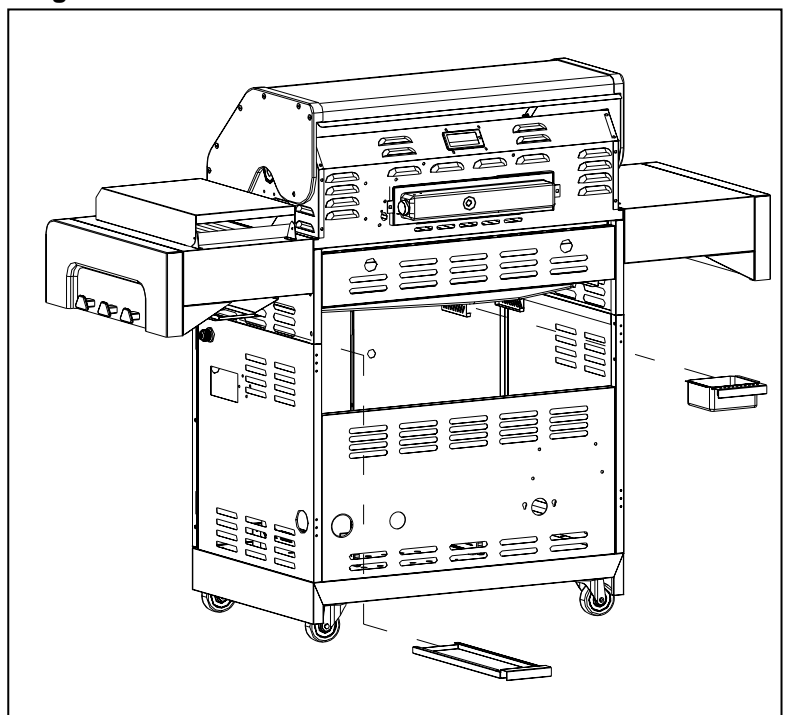

Step 9: Flame Tamer, Cooking Grid, and Warming Rack Assembly

Place the flame tamer between 2 brackets inside the firebox, place the cooking grids over the flame tamers, then place the warming rack into the firebox side baffles. See Fig. 16

Fig. 16

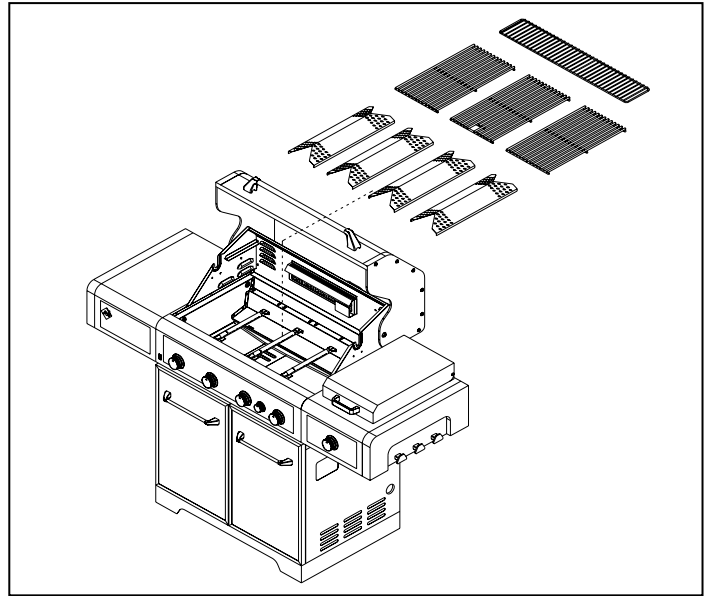

Step 10: Propane Gas Tank Assembly

To release the tank tray glides, slide the bracket up 90 degrees.

To lock tank tray glides, slide the bracket to the left 90 degrees. See Fig. 17

Secure the tank with the tightening the bolt after the tank has been placed in the tray. See Fig. 18

Fig. 17

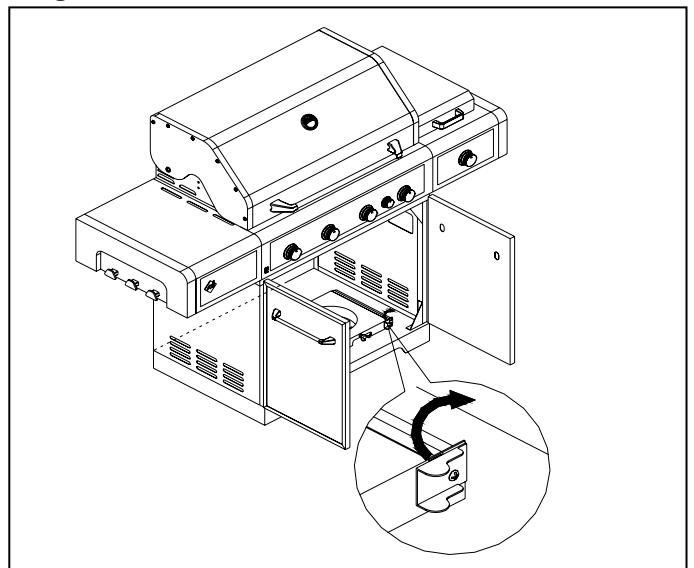
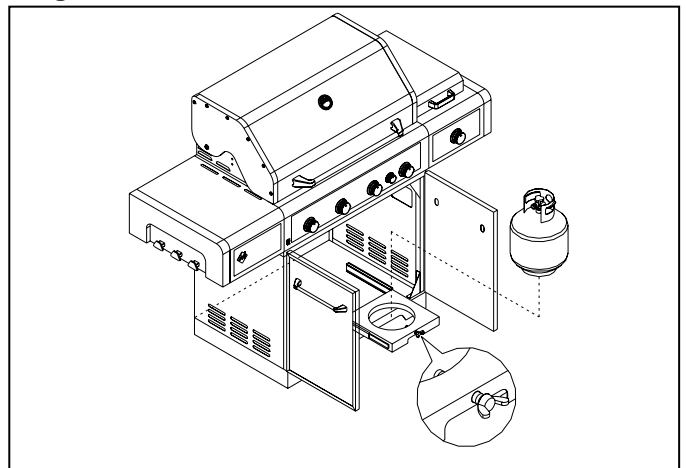

Fig. 18



Notice

This grill is equipped with dual fuel valves and can be converted from Liquid Propane gas supply to Natural Gas supply. Conversion kits may be purchased through

www.samsclub.com

For grill model #720-0691A, the NG conversion kit is model # 710-0691A.

Please purchase the conversion kits appropriate for your gas grill model, and follow conversion step from page 33-38.

NEVER CONNECT AN UNREGULATED GAS SUPPLY LINE TO THE APPLIANCE. USE THE REGULATOR/HOSE ASSEMBLY SUPPLIED.

This is a liquid propane configured grill. Do not attempt to use a natural gas supply unless the grill has been reconfigured for natural gas use.

Total gas consumption (per hour) of this stainless steel gas grill with all burners on "HI":

Main burner	40,000 Btu/h
Sear burner	15,000 Btu/hr
<u>Rear burner</u>	<u>13,000 Btu/hr</u>
Total	68,000 Btu/hr.

L.P. TANK REQUIREMENT

A dented or rusty L.P. tank may be hazardous and should be checked by your L.P. supplier. Never use a cylinder with a damaged valve. The L.P. gas cylinder must be constructed and marked in accordance with the specifications for L.P. gas cylinders of the U.S. Department of Transportation (DOT) or the National Standard of Canada, CAN/CSA-B339, Cylinders, Spheres and Tubes for Transportation of Dangerous Goods; and Commission, as applicable. Overfilling prevention device (OPD) shall be provided on cylinder & QCCI connection on the cylinder valve, ANSI/CGA-V-1. The cylinder supply system must be arrange for vapor withdrawal. The cylinder must include a collar to protect the cylinder valve. The cylinder must be provided with a shut off valve terminating in an L.P. gas supply cylinder valve outlet specified, as applicable, for connection type QCC1 in the standard for compressed gas cylinder valve outlet and inlet connection ANSI/CGA-V-1. Manifold pressure: 11"(27.94cm) water column (W.C.).

L.P. GAS HOOK-UP

Ensure that the black plastic grommets on the LP cylinder valve are in place and that the hose does not come into contact with the grease tray or the grill head.

CONNECTION

Your stainless steel grill is equipped with gas supply orifices for use only with liquid propane gas. It is also equipped with a high capacity hose/regulator assembly for connection to a standard 20lb. L.P. cylinder (18-1/4" (46.35cm) high, 12-1/4"(31cm) diameter). To connect the L.P. gas supply cylinder, please follow the steps below:

1. Make sure tank valve is in its full off position (turn clockwise to stop)
2. Check tank valve to assure it has proper external male threads (type 1 connection per ANSIZ21.81)

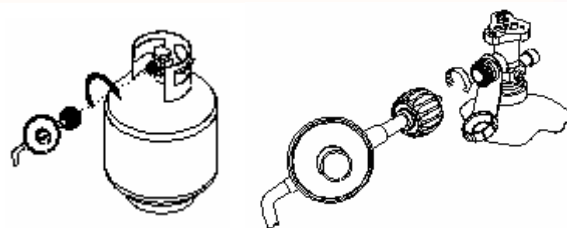

3. Make sure all burner valves are in their off position.
4. Inspect valve connections, port, and regulator assembly. Look for any damage or debris. Remove any debris. Inspect hose for damage. Never attempt to use damaged or obstructed equipment. See your local L.P. gas dealer for repair.
5. When connecting regulator assembly to the valve, hand tighten the quick coupling nut clockwise to a complete stop. Do not use a wrench to tighten. Use of a wrench may damage the quick coupling nut and result in a hazardous condition.
6. Open the tank valve fully (counterclockwise). Apply the soap solution with a clean brush to all gas connections. See below. If growing bubbles appear in the solution the connections are not properly sealed. Check each fitting and tighten or repair as necessary.



7. If you have a gas connection leak you cannot repair, turn gas OFF at supply tank, disconnect fuel line from your grill and call 1-800-790-1299 or your gas supplier for repair assistance.
8. Also apply soapy solution to the tank seams. See below. If growing bubbles appear, shut tank OFF and do not use or move it! Contact an LP gas supplier or your fire department for assistance.

To disconnect L.P. gas cylinder:

1. Turn the burner valves off.
2. Turn the tank valve off fully (turn clockwise to stop).
3. Detach the regulator assembly from the tank valve by turning the quick coupling nut counterclockwise.

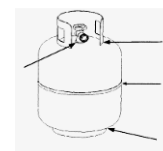

Installer Final Check List

- ✓ **Minimum clearance from sides and back of unit to combustible construction, 24 inches (61cm) from sides and 24 inches (61cm) from back**
- ✓ **All internal packaging removed.**
- ✓ **Knobs turn freely.**
- ✓ **Burners are tight and sitting properly on orifices.**
- ✓ **Pressure regulator connected and set. Gas connections to grill using hose & regulator assembly provided (pre-set for 11.0" water column).**
- ✓ **Unit tested and free of leaks.**
- ✓ **User informed of gas supply shut off valve location**

USER, PLEASE RETAIN THIS MANUAL FOR FUTURE REFERENCE.

PROPANE CYLINDER CAUTIONS

- a) **Do Not store a spare LP-gas cylinder under or near this appliance.**
- b) **NEVER fill the cylinder beyond 80 percent full.**
- c) **If the information in "a" and "b" is not followed exactly, a fire or explosion causing death or serious injury may occur.**

Leak Testing

GENERAL

Although all gas connections on the grill are leak tested at the factory prior to shipment, a complete gas tightness check must be performed at the installation site due to possible mishandling in shipment, or excessive pressure unknowingly being applied to the unit. Periodically check the whole system for leaks following the procedures listed below. If the smell of gas is detected at anytime you should immediately check the entire system for leaks.

BEFORE TESTING

Make sure that all packing material is removed from the grill including tie-down straps.

DO NOT SMOKE WHILE LEAK TESTING.

NEVER PERFORM LEAK TEST WITH AN OPEN FLAME.

Make a soap solution of one part liquid detergent and one part water. You will need a spray bottle, brush, or rag to apply the solution to the fittings. For the initial leak test, make sure the L.P. cylinder is 80% full.

TO TEST

1. Make sure the control valves are in the "OFF" position, and turn on the gas supply.
2. Check all connections from the LP gas regulator and supply valve up to and including the connection to the manifold pipe assembly (the pipe that goes to the burners). Soap bubbles will appear where a leak is present.
3. If a leak is present, immediately turn off the gas supply and tighten the leaky fittings.
4. Turn the gas back on and recheck.
5. Should the gas continue to leak from any of the fittings, turn off the gas supply and contact customer service at 1-800-790-1299.



Only those parts recommended by the manufacturer should be used on the grill.

Substitution will void the warranty. Do not use the grill until all connections have been checked and do not leak.

GAS FLOW CHECK

Each grill burner is tested and adjusted at the factory prior to shipment; however, variations in the local gas supply may make it necessary to adjust the burners. The flames of the burners should be visually checked.

Flames should be blue and stable with no yellow tips, excessive noise or lifting. If any of these conditions exist, check to see if the air shutter or burner ports are blocked by dirt, debris, spider webs, etc. If you have any questions regarding flame stability, please call customer service 1-800-790-1299 .

ALWAYS CHECK FOR LEAKS AFTER EVERY L.P. TANK CHANGE

Check all gas supply fittings for leaks before each use. It is handy to keep a spray bottle of soapy water near the shut-off valve of the gas supply line. Spray all the fittings. Bubbles indicate leaks.

CAUTIONS

Place dust cap on cylinder valve outlet when the cylinder is not in use. Only install the type of dust cap on the cylinder valve outlet that is provided with the cylinder valve. Other types of caps or plugs may result in leakage of propane.

The gas must be turned off at the supply cylinder when the unit is not in use.

If the appliance is stored indoors the cylinder must be disconnected and removed from the appliance. Cylinders must be stored outdoors in a well-ventilated area out of the reach of children.

Your grill is ready to use!

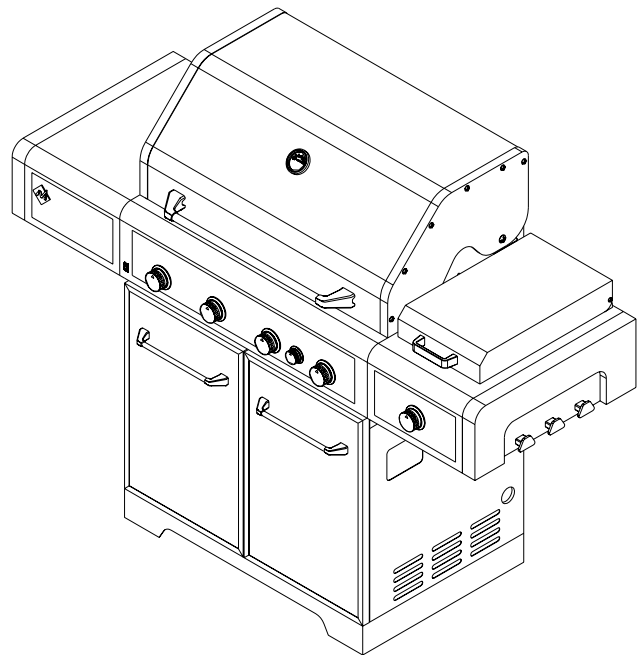
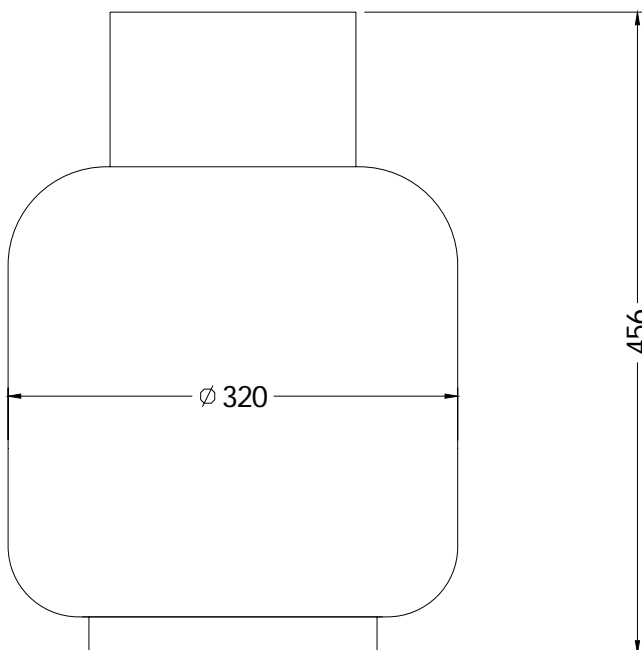

Your unit requires a rotisserie kit that fits a 30" firebox. Larger rotisserie kits can be used but will deny access to the searing side burner when using the rotisserie, if you want it, you can buy it from www.samsclub.com.

GENERAL USE OF THE GRILL AND ROTISSERIE

Each main burner is rated at 10,000 Btu/hr. The main grill burners encompass the entire cooking area and are side ported to minimize blockage from falling grease and debris. The igniter knobs are located on the lower center portion of the valve panel. Each rotary igniter is labeled on the control panel.

USING THE GRILL

Grilling requires high heat for searing and proper browning. Most foods are cooked at the "HI" heat setting for the entire cooking time. However, when grilling large pieces of meat or poultry, it may be necessary to turn the heat to the lower setting after the initial browning. This cooks the food through without burning the outside. Foods cooked for a long time or foods basted with a sugary marinade may need the lower heat setting near the end of the cooking time.

NOTE: This grill is designed to grill efficiently without the use of lava rocks or briquettes of any kind. Heat is radiated by the stainless steel flame tamers positioned above each burner.

NOTE: The hot grill sears the food, sealing in the juices. The more thoroughly the grill is preheated, the faster the meat browns and the darker the grill marks.

DO NOT LEAVE THE GRILL UNATTENDED WHILE COOKING.

WARNING: IMPORTANT!

USING THE SIDE BURNER

Inspect the gas supply hose prior to turning the gas "ON". If there is evidence of cuts, wear or abrasion, it must be replaced prior to use. Do not use the side burner if the odor of gas is present.

Grill Lighting Instructions

WARNING: IMPORTANT! BEFORE LIGHTING...

Inspect the gas supply hose prior to turning the gas "ON". If there is evidence of cuts, wear, or abrasion, it must be replaced prior to use. Do not use the grill if the odor of gas is present. Only the pressure regulator and hose assembly supplied with the unit should be used.

Never substitute regulators and hose assembly for those supplied with the grill. If a replacement is necessary, contact the manufacturer for proper replacement. The replacement must be that specified in the manual.

WARNING: Always keep your face and body as far away from the burner as possible when lighting.

TO LIGHT THE MAIN BURNER

Make sure all knobs are "OFF" then turn on the gas supply from the LP tank. Always keep your face and body as far from the grill as possible when lighting.

Your grill has an exclusive patented built-in ignition. The igniter is built into the valve. To ignite each burner simply push and turn the control knobs to the HI setting, you will hear the valve click as it sends a spark to the pilot flame. If the burner does not light wait 5 minutes for any excess gas to dissipate and then retry.

TO LIGHT THE SEARING SIDE BURNER

To light the searing side burner, remove any cooking utensils from the burner grate. Push and turn the control knob counterclockwise to the "IGNITE/ON" position. If the burner does not light, turn the control knob to "OFF". If the smell of gas is detected and the igniter is not functioning, immediately turn the control knob "OFF". Allow 5 minutes for any accumulated gas to dissipate. If the side burner igniter is not functioning, see the following section for match lighting.

TO MATCH LIGHT THE GRILL

If the burner will not light after several attempts then the burner can be match lit.

Match light extension rod is located on the inside panel of the door.

If you've just attempted to light the burner with the igniter, allow 5 minutes for any accumulated gas to dissipate. Keep your face and hands as far away from the grill as possible. Insert a lit match attached to the lighting rod through the cooking grids to the burner. Press the control knob and rotate left to the HI/ON setting continue to press the knob until the burner ignites. Burner should light immediately. If the burner does not light in 4 seconds turn the knob off, wait 5 minutes and try again.

TO MATCH LIGHT THE SIDE BURNER

Hold a lit extended match near the side burner ports, turn the control knob counterclockwise to "IGNITE/HI". Move your hand immediately once the burner is lit. Rotate the control knob to the desired setting.

Keep a spray bottle of soapy water near the gas supply valve and check the connections before each use.

Do not attempt to light the grill if odor of gas is present. Call for service 1-800-790-1299

FLAME CHARACTERISTICS

Check for proper burner flame characteristics.

Burner flames should be blue and stable with no yellow tips, excessive noise, or lifting. If any of these conditions exist call our customer service line. If the flame is yellow, it indicates insufficient air. If the flame is noisy and tends to lift away from the burner, it indicates too much air.

Each burner is adjusted prior to shipment; however, variations in the local gas supply may make minor adjustments necessary.

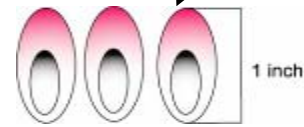
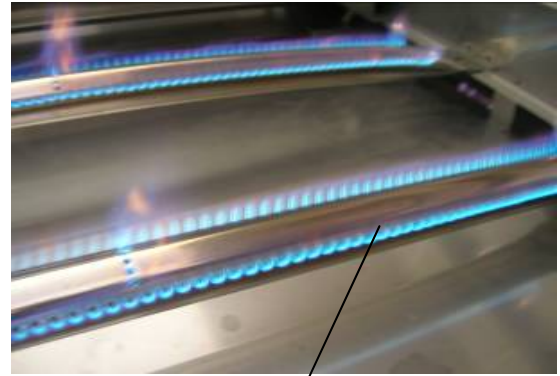

Visually check the burner flames prior to each use, The flames should look like this picture, if they do not, refer to the burner maintenance part of this manual.

Lighting Instructions

Note: Remove all packaging, including straps, before using the grill

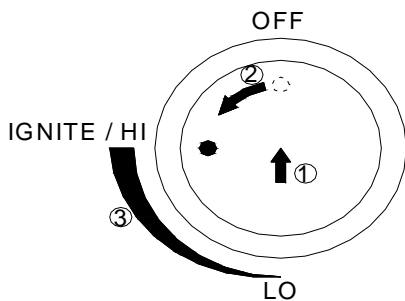
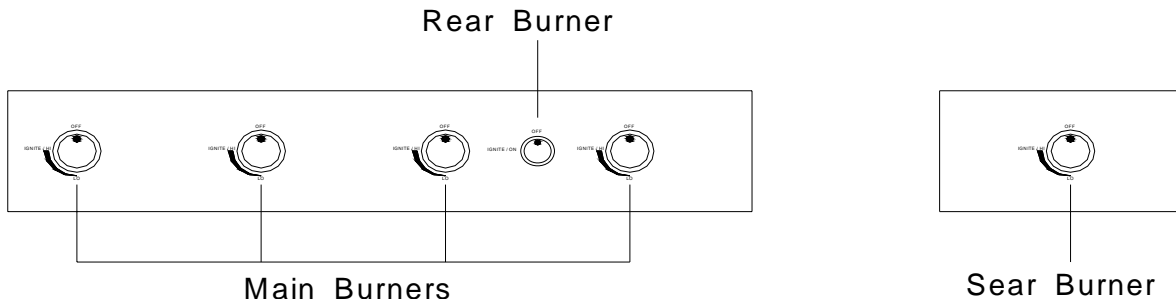

- 1** Make sure the lid is open.
- 2** Push and turn Main Burner knob slowly to IGNITE/HI. Keep knob pressed in until the burner is lit.
- 3** If burner does not light within 5 seconds, turn the knob to OFF and repeat the lighting instruction.
- 4** If burner does not light up after step 3, turn the knob to OFF, wait 5 minutes, and repeat the lighting procedure or light by match.

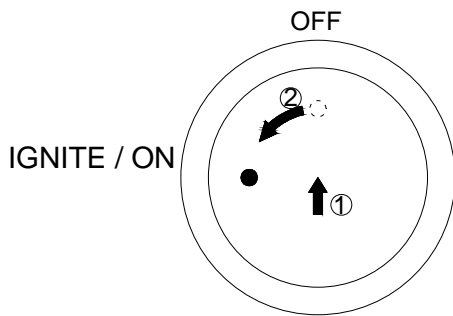

- ① Make sure the lid is open.
- ② Push and slowly turn the Rear Burner knob to IGNITE/ON position. Keep knob pressed in until the burner is lit. Once it is lit, continue to press and hold for another 15 seconds to ensure the burner stays lit.
- ③ If burner does not light within 5 seconds, turn the knob to OFF position and repeat the lighting procedure.
- ④ If burner fails to light after step 3, turn the knob to OFF position, wait 5 minutes, then repeat the lighting procedure or light by match.

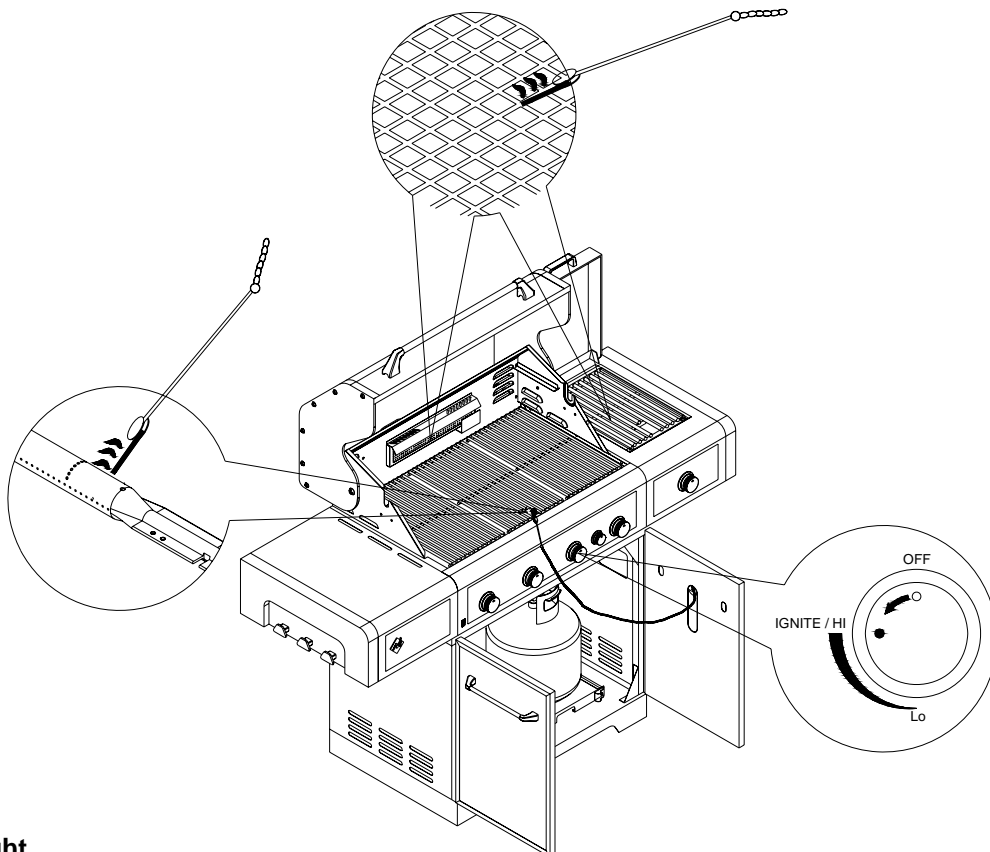

Match light

1. If the burner will not light after several attempts then the burner can be match lit, before using the match allow 5 minutes for any accumulated gas to dissipate.
2. Clip a paper match on one end of the lighting rod.
3. Light match.
4. Hold lighting rod and insert lighted match right next to the burner ports or ceramic file.
5. Push and turn the designated control knob to IGNITE/HI.
6. Burner should ignite immediately.

Light Operation Instruction

Make sure light's power switch on the control panel is in the "OFF" position. Connect power plug to properly grounded outlet. Turn the light's power switch to "ON".

WARNING

Keep any electrical supply cord away from any heated surface.

Bulb Replacement

1. Make sure the light's power switch on the control panel is in the "OFF" position and power plug is disconnected from outlet.
2. Use a screwdriver to loosen the screw securing the light cover and remove it. (**NOTE:** While loosening the fourth screws of light cover, use another hand to hold the cover to avoid it falls down. Then remove the light cover.)
3. Loosen the securing the light.
4. Remove the glass cover from the light compartment. (**HINT:** Use a flat head screwdriver to open it easily.)
5. Use a flathead screwdriver to loosen the four screws locking the bulb in place. (Loosen but not remove the nether two screws under the light first.)
6. Pull out the light bulb and replace with a new bulb. Tighten the four screws. (Note: Do not touch the halogen bulb with bare hands.)
7. To re-install the light, replace the glass cover, insert the light bulb housing into the grill and insert and tighten the screw.

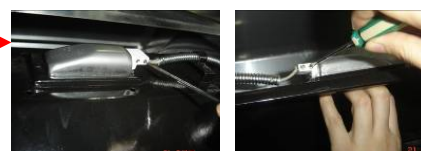
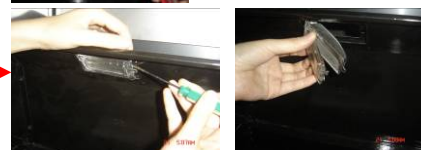
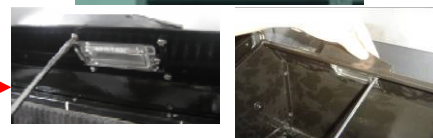

Cleaning Method

Follow steps 1-4 above for glass cover removal. Use a damp towel to clean the surface of glass cover. Make sure the glass cover is completely dry before re-installing.

WARNING

Make sure the light switch is in the "OFF" position and power plug is disconnected from power outlet prior to cleaning the glass cover.

WARNING

The light glass cover should not be in contact with water or any other liquid when it's warm. Sudden change of temperature may cause cracks on glass cover.

Bulb Specification

Bulb Type: Halogen

Wattage: 10 watts per bulb

Voltage: 12 volts

Please contact customer service at [1-800-790-1299](tel:1-800-790-1299) for assistance on bulb replacement information.

WARNING

To ensure continued protection against electric shock: Connect to properly grounded outlets only. Do not expose to rain. Keep extension cord connections dry and off the ground.

STAINLESS STEEL

There are many different stainless steel cleaners available. Always use the mildest cleaning procedure first, scrubbing in the direction of the grain. Specks of grease can gather on the surfaces of the stainless steel and bake on to the surface and give the appearance of rust. For removal use a mild abrasive pad in conjunction with a stainless steel cleaner.

GRILL GRATE

The easiest way to clean the grill is immediately after cooking is completed and after turning off the flame. Wear a barbecue mitt to protect your hand from the heat and steam. Dip a brass bristle barbecue brush in water and scrub the hot grill. Dip the brush frequently in the bowl of water. Steam, created as water contacts the hot grill, assists the cleaning process by softening any food particles. If the grill is allowed to cool before cleaning, cleaning will be more difficult.

ENSURE THAT THE GAS SUPPLY AND THE KNOBS ARE IN THE "OFF" POSITION. MAKE SURE THE RANGE TOP BURNER IS COOL BEFORE REMOVAL.

GRILL BURNERS

Extreme care should be taken when moving a burner as it must be correctly centered on the orifice before any attempt is made to relight the grill. Frequency of cleaning will depend on how often you use the grill.

MAIN GRILL BURNER CLEANING

Ensure the gas supply is off and the knobs are in the "OFF" position. Make sure the grill is cool. Clean the exterior of the burner with a wire brush. Clear stubborn scale with a metal scraper. Clear any clogged ports with a straightened paper clip. Never use a wooden toothpick as it may break off and clog the port. Please note if insects or other obstructions are blocking the flow of gas through the burner, and if so you will need to call our customer service line 1-800-790-1299.

GREASE TRAY CLEANING

The grease tray should be emptied and wiped down periodically and wash with a mild detergent and warm water solution. A small amount of sand may be placed in bottom of grease tray to absorb the grease. Check the grease tray frequently, do not allow excess grease to accumulate and overflow out of the grease tray.

BURNER CLEANING

1. Turn off the gas supply, and make sure all the knobs are in the "OFF" position.
2. Wait for the grill to cool.
3. Clean the exterior of the burner with a wire brush. Use a metal scraper to stubborn stains.
4. Clear clogged port with a straightened paper clip. Never use a wooden toothpick as it may break off and clog the port.
5. If inserts or other obstructions are blocking the flow of gas through the burner, call customer service at 1-800-790-1299.

Warning: If you wish to replace main burner, we strongly recommend that you hire a professionally trained technician to replace it. Please understand that we will not be responsible for any liability, personal injury, or property damage resulting from an improperly assembled burner.

HOW TO REPLACE MAIN BURNER

Step 1. Insert the burner onto the orifice. As show below, make sure burner hole aim at orifice .



Step 2. Secure the main burner on the back wall of fire box with 1 screw.



STAINLESS STEEL

There are many different stainless steel cleaners available. Always use the mildest cleaning procedure first, scrubbing in the direction of the grain. Do not use steel wool as it will scratch the surface. To touch up noticeable scratches in the stainless steel, sand very lightly with dry 100 grit emery paper in the direction of the grain.

CAUTION

1. Keep outdoor cooking gas appliance area clear and free from combustible materials, gasoline and other flammable vapors and liquids.
2. Do not obstruct the flow of combustible and ventilation air.
3. Keep the ventilation openings of the cylinder enclosure free and clear from debris.

SPIDER AND INSECT WARNING

Checking and cleaning burner/ venturi tubes for insects and insect nests. A clogged tube can lead to a fire beneath the grill.

Spiders and small insects occasionally spin webs or make nests in the grill burner tubes during transit and warehousing. These webs can lead to gas flow obstruction which could result in a fire in and around burner tubes. This type of fire is known as "FLASH-BACK" and can cause serious damage to your grill and create an unsafe operating condition for the user.

Although an obstructed burner tube is not the only cause of "FLASH-BACK", it is the most common cause.

To reduce the chance of "FLASH-BACK", you must clean the burner tubes before assembling your grill, and at least once a month in late summer or early fall when spiders are most active. Also perform this burner tube cleaning procedure if your grill has not been used for an extended period of time.

WHEN TO LOOK FOR SPIDERS

You should inspect the burners at least once a year or immediately after any of the following conditions occur:

1. The smell of gas in conjunction with the burner flames appearing yellow.
2. The grill does not reach temperature.
3. The grill heats unevenly.
4. The burners make popping noises.

BEFORE CALLING FOR SERVICE

If the grill does not function properly, use the following check list before contacting your dealer for service. You may save the cost of a service call.

PREHEATING: The grill lid should be in a closed position during the preheat time period. It is necessary to preheat the grill before cooking certain foods, depending on the type of food and the cooking temperature. Food that requires a high cooking temperature needs a pre-heat period of five minutes; food that requires a lower cooking temperature needs only a period of two to three minutes.

COOKING TEMPERATURES

High setting-Use this setting for fast warm-up, for searing steaks and chops, and grilling.

Low setting-Use this setting for all roasting, baking, and when cooking very lean cuts such as fish.

These temperatures vary with the outside temperature and the amount of wind.

Cooking with in-direct Heat: You can cook poultry and large cuts of meat slowly to perfection on one side of the grill by indirect heat from the burner on the other side. Heat from the lighted burner circulates gently throughout the grill, cooking the meat or poultry without any direct flame touching it. This method greatly reduces flare-ups when cooking extra fatty cuts, because there is no direct flame to light the fats and juices that drip down during cooking.

CAUTION: If burners go out during operation, close gas supply at source, and turn all gas valves off. Open lid and wait five minutes before attempting to re-light (this allows accumulated gas fumes to clear).

CAUTION: Should a grease fire occur, close gas supply at source, turn off all burners and leave lid closed until fire is out.

CAUTION: DO NOT attempt to disconnect any gas fitting while your grill is in operation. As with all appliances, proper care and maintenance will keep them in top operating condition and prolong their life. Your gas grill is no exception.

CAUTION :Side burner lid will get hot if used when lid is closed.

PROBLEM	SOLUTION
When attempting to light my grill, it will not light immediately.	<p>Make sure you have a spark while you are trying to light the burner (if no spark) Ensure that the wire is connected to the electrode assembly.</p> <p>Clean wire (s) and / or electrode with rubbing alcohol and a clean swab. Wipe with a clean cloth.</p> <p>Check to see if the other burners operate. If so. Check the gas orifice on the malfunctioning burner for an obstruction.</p>
Rotisserie burner will not light when the igniter button is pushed.	<p>Check to see if debris is blocking the electrode.</p> <p>Check to see if there is a spark that jumps to the burner from the electrode. If no spark is seen, check the battery located inside the igniter box. To open turn counter</p> <p>Does the infrared back burner light when attempting to light with a match ? If not, check to ensure the gas is on.</p>
Regulator makes noise.	<p>Vent hose on the regulator may be plugged or regulator may be faulty. Ensure the vent hole on the regulator is not obstructed. Clear the hole, close the gas control valves. Wait ten minutes and re-start.</p> <p>Check your flames for proper performance. If the flames are not correct, replace regulator.</p>
Full size cover does not fit the grill.	<p>Cover may be incorrect for your grill. It may be a tight fit.</p> <p>Ensure the cover is the correct length for your grill.</p> <p>Measure it left to right. Compare to the grill's measurement.</p> <p>Compare the location and size of the hood portion of the cover to your grill.</p> <p>Spread the cover and allow it to relax, preferably in warm sunlight or in a warm room.</p> <p>For grill with a side shelf bunch the cover like a sock, put on left to right.</p>
Rotisserie motor will not turn	<p>Ensure the motor is connected to a properly grounded power supply.</p> <p>Ensure the on / off switch is in the on position.</p> <p>Ensure that the spit is fully inserted into the rotisserie motor.</p> <p>Ensure that the load does not exceed the 40 pounds operational capacity.</p> <p>Ensure that there is no encumbrance or drag.</p>
Grill only heats to 200-300 degrees.	<p>Check to see if the fuel hose is bent or kinked.</p> <p>Make sure the grill area is clear of dust.</p> <p>Make sure the burner and orifices are clean.</p> <p>Check for spiders and insects.</p> <p>The regulator has a safety device that restricts the flow of gas in the event of a leak. This safety device can be triggered with out a gas leak. To reset the safety device, turn off all burners and close the LP tank valve. Disconnect the regulator from the LP tank and wait one minute. Reconnect the regulator to the LP tank and slowly open the LP tank valve until the valve is fully open. Light all burners and observe the temperature.</p>
Grill takes a long time to preheat.	<p>Normal preheat 500-600 degrees, takes about 10-15 min. Cold weather and wind may effect your preheat time.</p> <p>If you are using volcanic rock or briquettes they can increase the preheat time and maximum temperature.</p>
Burner flames are not light blue.	<p>Too much or not enough air for the flame.</p> <p>Elevation is the principal cause, however cold weather can affect the mixture.</p> <p>Burner adjustment may be required.</p> <p>Grill is in a windy location.</p>

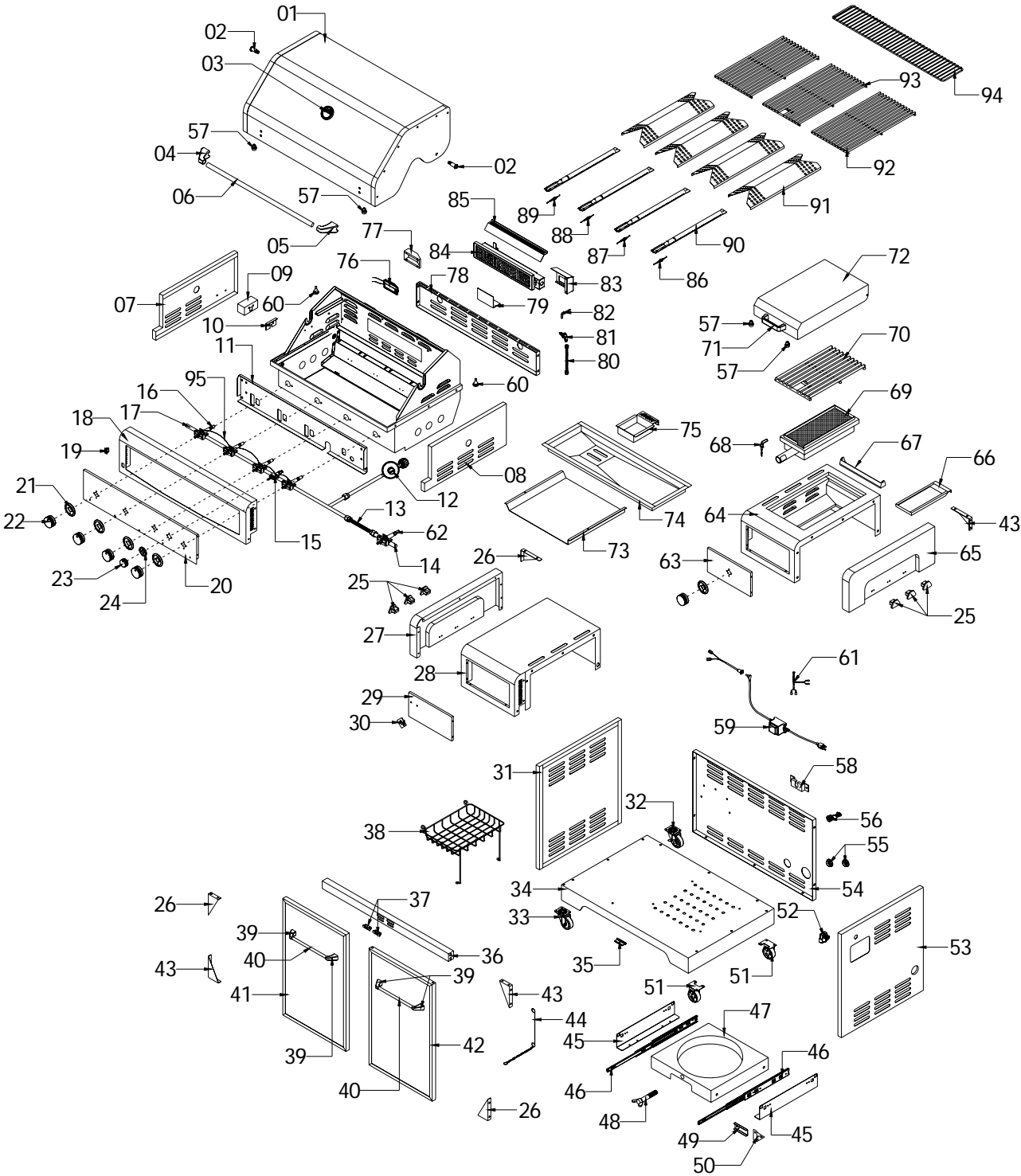

Part List

No.	Part (Description)	Warranty coverage	QTY	No.	Part (Description)	Warranty coverage	QTY
01	Main Lid	1	1	28	Side shelf, Left	1	1
02	Main Lid screw	1	2	29	Side shelf front trim panel, left	1	1
03	Temperature gauge	1	1	30	Logo	1	1
04	Main lid handle seat, left	1	1	31	Side panel, Left	1	1
05	Main lid handle seat, right	1	1	32	Swivel caster with Brake	1	1
06	Main Lid handle	1	1	33	Swivel caster	1	1
07	Flange, Left	1	1	34	Bottom panel	1	1
08	Flange, right	1	1	35	L Shape Bracket	1	1
09	Electronic wire waterproof box	1	1	36	Cart Frame	1	1
10	Transformer stator bracket	1	1	37	Door Magnet	1	2
11	Front baffle	1	1	38	Cart bracket	1	1
12	Regulator LP	1	1	39	Door Handle Seat	1	4
13	Side Burner Flex Gas Line	1	1	40	Door Handle Tube	1	2
14	Side manifold	1	1	41	Front Door, Left	1	1
15	Rotisserie gas valve	1	1	42	Front Door, Right	1	1
16	Main Gas Valve	1	4	43	Triangle Bracket for Side Burner	1	3
17	Main manifold	1	1	44	Lighting rod	1	1
18	Main Control Panel	1	1	45	Tank tray bracket	1	2
19	Light switch	1	1	46	Tank tray slide	1	2
20	Main control trim panel	1	1	47	Tank tray	1	1
21	Bezel A	1	5	48	Tank bolt	1	1
22	Control knob A	1	5	49	Gas tank tray bracket	1	1
23	Bezel B	1	1	50	Tank tray bracket supporting	1	1
24	Control Knob B	1	1	51	Caster	1	2
25	Utensil hook	1	6	52	Electronic igniter module	1	1
26	Triangle Bracket for Side shelf	1	3	53	Side panel, right	1	1
27	Side shelf trim panel, left	1	1	54	Back panel	1	1

No.	Part (Description)	Warranty coverage	QTY	No.	Part (Description)	Warranty coverage	QTY
55	Rubber grommet	1	2	78	Back panel, top	1	1
56	Cable Strainer	1	2	79	Rotisserie burner igniter bracket	1	1
57	Hood Buffer B	1	4	80	Rotisserie flex gas line	1	1
58	Powder cord fix bracket	1	1	81	Rotisserie orifice w/brass elbow	1	1
59	Transformer	1	1	82	Rotisserie igniter wire	1	1
60	Hood Buffer A	1	2	83	Rear baffle	1	1
61	Lamp Cord	1	1	84	Rotisserie Burner	1	1
62	Side gas valve	1	1	85	Rotisserie Heat shield	1	1
63	Side shelf front trim panel, right	1	1	86	Main burner igniter A	1	1
64	Side Burner Bowl Assembly	1	1	87	Main burner igniter B	1	1
65	Side shelf trim panel, right	1	1	88	Main burner igniter C	1	1
66	Side burner grease tray	1	1	89	Main burner igniter D	1	1
67	Side Burner Lid Support Bracket	1	1	90	Main Burner	5	4
68	Sear burner igniter wire	1	1	91	Flame tamer	1	4
69	Sear burner	1	1	92	Cooking grid	3	2
70	Side Burner Cooking Grid	1	1	93	Cooking grid with hole	3	1
71	Side Burner Lid Handle	1	1	94	Warming rack	1	1
72	Side burner lid	1	1	95	Igniter junction wire	1	1
73	Tank heat shield	1	1	96	Manual	1	1
74	Grease slide panel, bottom	1	1	97	PVC cover	1	1
75	Grease box	1	1	98	NG orifice pack	1	1
76	Lamp	1	1	99	pre-assembly hardware pack	1	1
77	Lamp case	1	1				

HOW TO ORDER REPLACEMENT PARTS

To make sure you obtain the correct replacement part(s) for your gas grill, please refer to the parts list on pages 26-27. The following information is required to assure getting the correct part. Please note the shipping cost for the delivery of any replacement parts will be on yourself.

- Gas grills model number (see data sticker on grill).
- Part number of replacement part needed.
- Description of replacement part needed.
- Quantity of parts needed.

To obtain replacement parts, contact Member's Mark Customer Relations.

1-800-790-1299

1-909-718-1953

Fax: 1- 909-718-1949

IMPORTANT

Use only factory authorized parts. The use of any part that is not factory authorized can be dangerous. This will also void your warranty.

Keep this assembly and operating instruction manual for convenient referral, and for replacement parts ordering.

CAUTION

Gas valves are present at the factory (valve assembly will be marked accordingly). If you wish to convert at some later date, be sure to contact your gas supplier or grill dealer before making the conversion.

Different orifices must be installed when converting from one type of gas to another. You will also need a data plate indicating what type of gas is used by the grill.

Grill Hints

The doneness of meat, whether rare, medium, or well done, is affected to a large degree by the thickness of the cut. Expert chefs say it is impossible to have a rare doneness with a thin cut of meat.

The cooking time is affected by the kind of meat, the size and shape of the cut, the temperature of the meat when cooking begins, and the degree of doneness desired.

When defrosting meats it is recommended that it be done overnight in the refrigerator as opposed to a microwave. This in general yields a juicier cut of meat.

Use a spatula instead of tongs or a fork to turn the meat, as a spatula will not puncture the meat and let the juices run out.

To get the juiciest meats, add seasoning or salt after the cooking is finished on each side and turn the meat only once (juices are lost when the meat is turned several times). Turn the meat just after the juices begin to bubble to the surface.

Trim any excess fat from the meat before cooking. To prevent steaks or chops from curling during cooking, slit the fat around the edges at 2-inch intervals.

DO NOT LEAVE THE GRILL UNATTENDED WHILE COOKING.

Grill Cooking Chart

FOOD	WEIGHT OR THICKNESS	HEAT SETTING	APPROXIMATE TIME	SPECIAL INSTRUCTIONS AND TIPS
VEGETABLES				Slice. Dot with butter or margarine. Wrap in heavy -duty foil. Grill, turning occasionally.
Fresh Beets Carrots Turnips		Medium	12 to 20 minutes	Grill, turning once. Brush occasionally with melted butter or margarine.
Onion	1/2 inch slices	Medium	8 to 20 minutes	Season with Italian dressing, butter, or margarine.
Potatoes Sweet White	Whole 6 to 8 ounces	Medium High	40 to 60 minutes 45 to 60 minutes	Wrap individually in heavy - duty foil. Grill, rotating occasionally.
Frozen Asparagus Peas Green beans Sprouts		Medium	15 to 30 minutes	Dot with butter or margarine. Wrap in heavy -duty foil. Grill, turning occasionally.

Grill Cooking Chart

continued

FOOD	WEIGHT OR THICKNESS	HEAT SETTING	APPROXIMATE TIME	SPECIAL INSTRUCTIONS AND TIPS
French fries		Medium	15 to 30 minutes	Place in aluminum foil pan. Grill, stirring occasionally
MEATS BEEF Hamburgers	1/2 to 3/4 inch	Medium	10 to 18 minutes	Grill, turning once when juices rise to the surfaces. Do not leave hamburgers unattended since a flare-up could occur quickly. Cook to internal temperature of 160 degrees
Tenderloin		High	8 to 15 minutes	
Rare	1 inch	High	8 to 14 minutes	Trim edges. Grill, turning once
Medium	1-1/2 inch	High	11 to 18 minutes	
	1 inch	Medium	12 to 22 minutes	
	1-1/2 inch	to High	16 to 27 minutes	
Well - done	1 inch 1-1/2 inches	Medium Medium	18 to 30 minutes 16 to 35 minutes	
LAMB Chop & Steaks Rare	1 inch 1-1/2 inch	Medium to High	10 to 15 minutes 14 to 18 minutes	Trim edges. Grill, turning once.
Medium	1 inch 1-1/2 inch	Medium to High	13 to 20 minutes 18 to 25 minutes	
PORK Chops	1 inch	Medium	20 to 30 minutes	Trim edges. Grill, turning once. Cook to desired doneness.
Well -done	1 -1/2 inches	Medium	30 to 40 minutes	
Ribs		Medium	30 to 40 minutes	Grill, turning occasionally. During last few minutes brush with barbecue sauce. Turn several times.
Ham steaks (precooked)	1 inch slices	High	4 to 8 minutes	Trim edges. Grill, turning once.
Hot dogs		Low	5 to 10 minutes	Slit skin. Grill, turning once.
POULTRY	2 to 3 pounds	Low or Medium	Up to 1 hour	Place skin side up. Grill, turning and brushing frequently with melted butter, margarine, oil or marinade.
Breasts well -done		Medium	30 to 45 minutes	Marinate as desired.
FISH AND SEAFOOD Halibut Salmon Swordfish	3/4 to 1 inch	Medium to High	8 to 15 minutes	Grill, turning once. Brush with melted butter, margarine or oil to keep moist.
Whole Cattfish Rainbow trout	4 to 8 ounce	Medium to High	12 to 20 minutes	Grill, turning once. Brush with melted butter, margarine or oil. Brush with melted butter and lemon juice.

BBQ SALMON

2 large salmon steaks
2 tbs. Oil
Salt & pepper
2 oz. thin bacon slices
2 tbs. Butter
1 tbs. Lemon juice
Spring of parsley
Lemon wedges

Preheat the BBQ.

Brush the steaks with oil and season with salt and pepper. Place on BBQ grill and cook for 10 minutes, turning steaks over halfway cooking time.

Meanwhile fry the bacon in a pan on the side burner. Drain on paper towels. Meld the butter in a small saucepan taking care not to discolor it. Arrange the fish and bacon on serving plates. Pour the butter over and sprinkle with lemon juice. Garnish with parsley springs and lemon wedges. Serve with boiled potatoes tossed in butter and sprinkled with chopped parsley and a crisp lettuce salad.

Note: Substitute catfish, halibut or cod for salmon.

BAKED CHILI CORN

6 medium ears corn, husked
3 tbs. Butter or margarine, melted
Dash ground cumin
Dash ground coriander

About ½ hour before cooking, turn the butter on for grill. Place each corn on a heavy-duty foil. In a bowl, combine remaining ingredients. Mix well. Brush 1-1/2 tsp. Butter mixture over each ear. Close foil and fold up ends to seal. Place on grill. Cook, turning packets occasionally 10 to 12 minutes or until cooked through.

TANGY SEAFOOD KABOBS

1 lb. Large shrimp, shelled & deveined
¾ lbs. sea scallops
2/3 c. chili sauce
¼ c. cider vinegar

butter and sprinkled with chopped parsley and a crisp lettuce salad. In medium bowl, combine shrimp and scallops. In small bowl combine chili sauce and next six ingredients. Pour over seafood. Toss to coat. Cover, refrigerate 2 hours.
3 tbs. chopped parsley
1 tbs. vegetable oil
1 tbs. Worcestershire sauce
½ tsp. prepared horseradish
1 cove garlic, minced
1 20 oz. Can pineapple chunks in juice, drained half hour before cooking, turn the burner to the grill on full. Drain seafood reserving marinade. On each of twelve 10" skewers, thread 2 shrimps and 2 scallops, alternating with pineapple chunks. Place skewers on grill. Cook 7-10 minutes, often basting and turning.

PORK CHOPS

4 Pork chops
Marinade
1 large onion
2 tbs. lemon juice or vinegar
2 tbs. oil
½ tsp. powdered mustard
2 tsp. Worcestershire sauce
½ tsp. freshly ground black pepper
1 tsp. sugar
½ tsp. paprika
1 clove garlic

Peel, grate onion, and add rest of the ingredients except the pork chops. Mix well. Pour over chops and marinate one hour in a cool place. Turn the BBQ grill on full. Heat 10 minutes.

BBQ the chops brushing with the marinade occasionally. Serve with mixed salad, dressed with vinaigrette flavored with fresh dill.

BARBECUED LONDON BROIL

4 to 6 servings
¾ c. Italian dressing
1 tsp. Worcestershire sauce
1 tsp. dry mustard
¼ tsp. thyme, crushed
1 medium onion, sliced
1 pound flank steak, scored
2 tbs. butter, melted

Combine first 4 ingredients, add onion and marinade flank steak with it. Refrigerate at least 4 hours or overnight. Remove steak and grill on your preheated BBQ grill. Grill 5 to 7 minutes on each side basting frequently with the marinade. In the meantime sauté onions from the marinade in butter in a skillet on your side burner for 3 minutes. To serve, slice steak diagonally into thin slices, sprinkle onions over top. Garnish with vegetable kabobs.

BARBECUED POTATOES and CHEESE

1-1/2 cups shredded cheddar cheese
1 can (10-3/4 oz.) condensed cream of mushroom soup
1/3 cup milk
2 tbs. barbecue sauce
¼ tsp. oregano
¼ tsp. salt
1/8 tsp. pepper
4 cups thinly sliced potatoes (4 medium-sized potatoes)

Preheat grill. Combine cheese, condensed soup, milk, BBQ sauce, oregano, salt and pepper in a large mixing bowl. Stir in potatoes until well coated. Turn into well buttered 1-1/2 quart rectangular baking dish. Cover dish with aluminum foil. Bake covered 25 minutes on medium with the lid of your BBQ grill closed. Remove foil and continue baking 15 minutes longer or until potatoes are tender. Let stand 5 minutes before serving.

VEGETABLE KABOBS

3 medium-sized zucchini
12 cherry tomatoes
12 fresh mushrooms
Grated Parmesan cheese
Parboil whole zucchini 5 minutes on your side burner or until just tender. Drain and cut into ½ inch slices. Thread zucchini, tomatoes and mushrooms alternately on each of six skewers. Brush with marinade made of Italian dressing, Worcestershire sauce, mustard and thyme. Grill 5 to 7 minutes turning and basting occasionally. Sprinkle liberally with Parmesan cheese.

FAJITAS

1-1/2 lb. flank steak or boned chicken breasts
 2 tbs. oil
 ½ cup lime juice
 ½ tsp. salt
 ½ tsp. celery salt
 ¼ tsp. garlic powder
 ½ tsp. pepper
 ¼ tsp. oregano
 ¼ tsp. cumin
 Flour tortillas lemon
 Pound flank steak to ¼ inch thickness or flatten chicken breasts. Mix oil, lime juice and seasonings in a zip lock bag. Add meat and shake bag to coat the meat. Refrigerate overnight or at least 6 to 8 hours. Wrap tortillas in foil. Remove meat from marinade. Cook on a pre-heated gas grill for 5 to 8 minutes on each side. While meat is cooking, heat tortillas on grill. Slice meat across grain in thin slices. Place on hot platter. Squeeze lemon juice over. Wrap meat and any of the following toppings in tortillas: chopped tomatoes, guacamole, sour cream, taco sauce.

BEEF AND LAMB KABOBS

Serve 4
 ½ lb. boneless sirloin or beef cut into 1" cubes
 ½ lb. boneless loin of lamb cut into 1" cubes
 2/3 c. water, divided
 ¼ c. chopped onion
 2 tbs. soy sauce
 ¼ c. vegetable oil, divided
 1 tbs. dark brown sugar
 1 tbs. fresh lemon juice
 2 cloves garlic, minced
 ¼ tsp. ground cumin
 ¼ tsp. ground coriander
 ¼ tsp. ground turmeric
 1/8 tsp. ground red pepper
 1/8 tsp. ground ginger
 1 red pepper cut into chunks
 1 large banana, cut into chunks
 8 small mushrooms
 1/3 c. smooth peanut butter
 In blender, process 1/3 c. water, onion, soy sauce, 2 tsp. oil and the next 8 ingredients until smooth. Pour over meat cubes and marinate about 4 hours, turning occasionally. Drain and reserve marinade. Onto to four 12" skewers alternately thread meat, pepper, banana and mushrooms. Preheat grill. Brush the kabobs with oil. Grill 7-8 minutes each side.

Bring marinade to boil on the side burner in a saucepan. Add remaining 1/3 c. water and peanut butter. Stir to blend. Heat through. If sauce gets too thick, add 1 tbs. water. Serve sauce with kabobs.

EGGPLANT CAVIAR

1 large eggplant
 2 tbs. olive oil
 2 tbs. wine vinegar
 2 tbs. finely chopped onion
 ½ clove garlic, minced
 1 medium tomato, chopped salt and pepper
 Roast eggplant on gas grill over medium flame, turning occasionally until thoroughly cooked. This may take 30 minutes. Remove from grill and cool for handling. Strip off the skin and chop eggplant finely. Add all the seasonings. Chill thoroughly and serve on toast.

CHICKEN TANDOORI STYLE

8 large chicken thighs or drumsticks
 1 c. plain nonfat yogurt
 ½ c. lemon juice
 2 tsp. salt
 ½ tsp. cayenne
 ½ tsp. black pepper
 ½ tsp. crushed garlic
 ½ tsp. grated ginger
 1 tbs. corn oil
 Combine all the ingredients in a large mixing bowl and marinate the chicken for 8 hours in the refrigerator. Drain the chicken and spread on the spit running the rod on the fleshier side of the bone. Rotis using the rotisserie burner. Cook on medium high heat for 40 minutes basting occasionally with the remainder of the marinade mixture. Serve with sliced onions and lemon wedges.

SPARE RIBS

Marinade:
 1 c. soy sauce
 ½ c. honey
 ½ c. vinegar
 ½ c. dry sherry
 2 tsp. chopped garlic
 2 tsp. sugar
 1 c. water
 1 chicken bouillon cube
 1 can beer for basting sauce

Marinate ribs for 3 hours. Use marinade for basting by adding beer to it. Place pan under the ribs and baste frequently. To cook ribs select lean, meaty ribs and accordion pleat them with your spit. Slide four prong meat hook down the length of spit and tighten. At the beginning of the rack and to its center, penetrate the second rib with the pointed end of the spit and push it between the meat. Skip a couple and continue the process until the entire rack is accordion pleated. Fasten the second meat hook into the rack. Turn your rotisserie burner on high. Rotis for 50 minutes or until done.

PORK ROAST

Apple cider vinegar basting sauce:
 1 c. apple cider vinegar
 6 oz. water
 ½ stick butter
 Salt, pepper, parsley and garlic seasoning
 2 oz. lemon juice
 10 lbs. pork roast
 Time: 1-1/2 hours to 2 hours
 Bring pork to room temperature before placing it on the spit rod. Place on the rod and test for balance. Light rotis burner. Turn control knob to high. Use the above basting sauce for rotissing.

TURKEY

12 lb. turkey
 Beer basting sauce:
 1 can beer
 12 oz. water
 1 stick butter
 1 tsp. salt
 1 tsp. pepper
 ½ tsp. garlic flakes
 1 tsp. parsley
 Thaw the bird completely. Wash inside out. Securely tie the legs and wings. Light rotisserie burner. Turn to high. Combine all the ingredients for basting sauce in a shallow pan. Place it under the turkey 15 to 20 minutes. Cook for approximately 3 hours. The basting sauce combined with turkey drippings makes a delicious gravy.

Member's Mark warrants to the original consumer-purchaser only that this product (*Model #720-0691A*) shall be free from defects in workmanship and materials after correct assembly and under normal and reasonable home use for the periods indicated below beginning on the date of purchase. The manufacturer reserves the right to require photographic evidence of damage, or that defective parts be returned, postage and or freight pre-paid by the consumer, for review and examination.

Burners: 5 year LIMITED warranty against perforation

Grids, grates & electronic ignition: 3 year LIMITED warranty

* Does not cover dropping, chipping, scratching or surface damage

Stainless steel parts: 3 year LIMITED warranty against perforation

* Does not cover cosmetic issue like surface corrosion, scratched and rust

All other parts: 1 year LIMITED warranty

* Does not cover chipping, scratching, cracking surface corrosion, scratches or rust

Upon consumer supplying proof of purchase as provided herein, Manufacturer will repair or replace the parts which are proven defective during the applicable warranty period. Parts required to complete such repair or replacement shall be free of charge to you except for shipping costs, as long as the purchaser is within the warranty period from the original date of purchase. The original consumer-purchaser will be responsible for all shipping charges of parts replaced under the terms of this limited warranty. This limited warranty is applicable in the United States only, is only available to the original owner of the product and is *not transferable*. Manufacturer requires reasonable proof of your date of purchase. Therefore, you should retain your sales receipt and/or invoice. If the unit was received as a gift, please ask the gift-giver to send in the receipt on your behalf, to the below address. Defective or missing parts subject to this limited warranty will not be replaced without registration or proof of purchase. This limited warranty applies to the functionality of the product **ONLY** and does not cover cosmetic issues such as scratches, dents, corruptions or discoloring by heat, abrasive and chemical cleaners or any tools used in the assembly or installation of the appliance, surface rust, or the discoloration of stainless steel surfaces. Surface rust, corrosion, or powder paint chipping on metal parts that does not affect the structural integrity of the product is not considered a defect in workmanship or material and is not covered by this warranty. This limited warranty will not reimburse you for the cost of any inconvenience, food, personal injury or property damage. If an original replacement part is not available, a comparable replacement part will be sent. You will be responsible for all shipping charges of parts replaced under the terms of this limited warranty.

ITEMS MANUFACTURER WILL NOT PAY FOR:

Service calls to your home.

Repairs when your product is used for other than normal, single-family household or residential use.

Damage resulting from accident, alteration, misuse, lack of maintenance/cleaning, abuse, fire, flood, acts of God, improper installation, and installation not in accordance with electrical or plumbing codes or use of products not approved by the manufacturer.

Any food loss due to product failures.

Replacement parts or repair labor costs for units operated outside the United States or Canada.

Pickup and delivery of your product.

Postage fees or photo processing fees for photos sent in as documentation.

Repairs to parts or systems resulting from unauthorized modifications made to the product.

The removal and/or reinstallation of your product.

Shipping cost, standard or expedited, for warranty/non warranty and replacement parts.

DISCLAIMER OF IMPLIED WARRANTIES: LIMITATION OF REMEDIES

Repair or replacement of defective parts is your exclusive remedy under the terms of this limited warranty. Manufacturer will not be responsible for any consequential or incidental damages arising from the breach of either this limited warranty or any applicable implied warranty, or for failure or damage resulting from acts of God, improper care and maintenance, grease fire, accident, alteration, replacement of parts by anyone other than Manufacturer, misuse, transportation, commercial use, abuse, hostile environments (inclement weather, acts of nature, animal tampering), improper installation or installation not in accordance with local codes or printed manufacturer instructions.

THIS LIMITED WARRANTY IS THE SOLE EXPRESS WARRANTY GIVEN BY THE MANUFACTURER. NO PRODUCT PERFORMANCE SPECIFICATION OR DESCRIPTION WHEREVER APPEARING IS WARRANTED BY MANUFACTURER EXCEPT TO THE EXTENT SET FORTH IN THIS LIMITED WARRANTY. ANY IMPLIED WARRANTY PROTECTION ARISING UNDER THE LAWS OF ANY STATE, INCLUDING IMPLIED WARRANTY OF MERCHANTABILITY OR FITNESS FOR A PARTICULAR PURPOSE OR USE, IS HEREBY LIMITED IN DURATION TO THE DURATION OF THIS LIMITED WARRANTY.

Neither dealers nor the retail establishment selling this product has any authority to make any additional warranties or to promise remedies in addition to or inconsistent with those stated above. Manufacturer's maximum liability, in any event, shall not exceed the documented purchase price of the product paid by the original consumer. This warranty only applies to units purchased from an authorized retailer and or re-seller. NOTE: Some states do not allow an exclusion or limitation of incidental or consequential damages, so some of the above limitations or exclusions may not apply to you; this limited warranty gives you specific legal rights as set for herein. You may also have other rights which vary from state to state.

If you wish to obtain performance of any obligation under this limited warranty, you should write to:

Member's Mark Customer Relations
5270 Edison Ave.
Chino, CA 91710

All consumer returns, parts orders, general questions, and troubleshooting assistance can be acquired by calling 1-800-790-1299.

Natural Gas Conversion for Model# 720-0691A

NG Conversion Kit for Model # 720-0691A

⚠ WARNING! FAILURE TO HEED THESE WARNINGS COULD RESULT IN A FIRE OR EXPLOSION THAT COULD CAUSE SERIOUS BODILY INJURY, DEATH OR PROPERTY DAMAGE.



Installation of this Natural Gas Conversion kit must be performed by a **QUALIFIED GAS TECHNICIAN ONLY**. **DO NOT ATTEMPT TO INSTALL THIS KIT YOURSELF**. Improper installation could result in a gas leak which could cause a fire or explosion and cause serious bodily injury, death or property damage. Leaks due to improper installation could occur immediately or slowly over time. If you hear any unusual noises or leaks, smell gas or unusual odors, or notice anything unusual with the operation of your gas appliance after the installation, immediately shut off the gas supply and discontinue use until the appliance is repaired by a **QUALIFIED GAS TECHNICIAN**.

If there are damaged or missing parts when you unpack this kit, call 1-800-790-1299. **DO NOT** have your **QUALIFIED GAS TECHNICIAN** attempt to install this kit until you receive replacement for any damaged or missing parts.

Orifice Chart

The different burner valves in this grill have different BTU ratings. This means that the amount of gas coming from each orifice varies in order to create the BTU's. The holes in the orifices themselves are drilled to different sizes so as to allow the proper amount of gas to flow through them. Please note the chart below as an easy reference for the various orifice opening sizes for the different valves in the grill.

720-0691A, 730-0691A orifice size

	Components	Liquid Propane (LP)		Natural Gas (NG)	
		Orifice Size	BTU	Orifice Size	BTU
	Main Burner	0.94mm	10,000	1.54mm	10,000
	Searing Side Burner	1.15mm	15,000	1.90mm	15,000
	Rear Burner	1.07mm	13,000	1.84mm	13,000

Below tools are included in package:



Allen Key



6mm Wrench



6mm Nut Driver

Natural Gas Conversion for Model# 720-0691A

Warning: Make sure all grill components are completely cool and gas supply is turned off and removed from grill prior to performing the conversion.

NG Hose and Regulator Conversion

Tools required:



Phillips Head Screwdriver (+)



14mm wrench

1. Turn all knobs to OFF. Turn off LP gas supply and remove the LP cylinder from the grill cart. Remove the brass adapter of the LP regulator from the manifold with a wrench.



2. Install the NG regulator hose (150mm) to the manifold and secure using a wrench. Tighten the NG regulator on the side panel with two 5/32*10mm screws that pre-assemble on the NG regulator.



Natural Gas Conversion for Model# 720-0691A

Note: Make sure the orifice will be lined with valve when loose out and replace orifice in Main Tube Burner Conversion, Searing Side Burner conversion and Rear burner Conversion. And then test gas leak accordingly.

Main Tube Burner Conversion

Tools required:



Phillips Head Screwdriver (+)



6 mm Nut Driver

Steps:

1. Remove the warming rack, cooking grids, and flame tamers.
2. Remove the main tube burners by removing the screws securing the burners near the back wall of the firebox and the screw near the front of the firebox that secures the igniter bracket to the burner. Gently lift the tube burners up and out.



3. Remove LP orifice with 6mm nut driver for each of the main burners, and replace with NG orifice by hand (4 main burner).

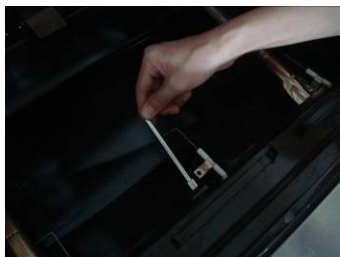

4. Replace the tube burners and screw back into original position.



Natural Gas Conversion for Model# 720-0691A

Searing Side Burner Conversion

Tools required:



Phillips Head Screwdriver (+)



6 mm Nut Driver

The step-by-step instruction for converting the searing side burner's orifice are stated below.

1. Remove the screw under C bracket to take off the C bracket, then remove the searing side burner LP orifice with 6mm driver.

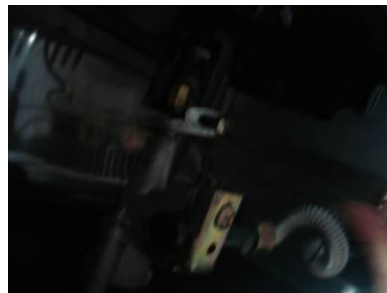

2. Remove the searing side burner LP orifice with 6mm, then Replace the NG orifice to the connector by hand from under side burner, then replace the side burner to the original position, tighten screw for four corners.

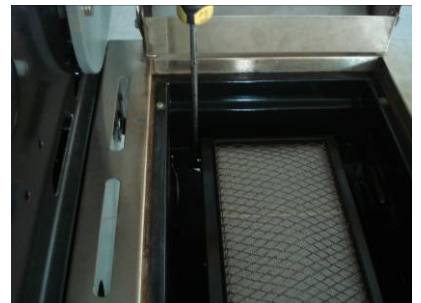

Natural Gas Conversion for Model# 720-0691A

Rear Burner Conversion

Tools required:



Phillips Head Screwdriver (+)



6mm Wrench

Steps:

1. Remove the screws securing the rear baffle from inside the firebox. Remove the Rear Baffle from the back of the grill.



2. Remove the LP orifice with 6mm wrench.



3. Replace the NG orifice with 6mm wrench. Then put rear baffle and screw back into original position.



Natural Gas Conversion for Item# /Model# 720-0691A

For Main Tube Burner Conversion Only

(The 3 steps below are not necessary for the Sear side burner and Rear burner)

You will need to adjust the High Flame setting screw when converting the barbecue from Propane to Natural Gas. Please follow the steps as detailed below.

1. Remove each Control Knob of main tube burners and sear side burner by loosening the socket head grub screw with the Allen key.
2. Use a screw driver to turn the High Flame Set Screw clockwise approximately 90 degree.
3. Check that burner operates at the new high fire setting - it may be necessary to adjust the screw setting slightly to get the ideal burner flame height.

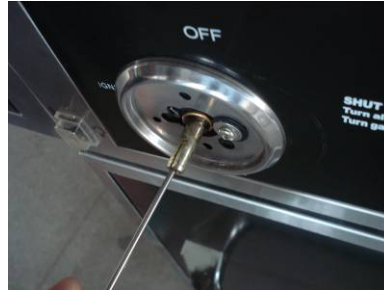

Warning!! Gas Valves are preset at the factory to operate on LP gas or NG gas. If you wish to convert, be sure to consult your gas supplier or trained technician for the conversion.

- A. After the Natural Gas regulator has been installed, attach the PVC Gas hose to the regulator (See drawing below).
- B. Connect the other end of the PVC Gas Hose to the house gas line using the quick-connect fitting. To use the quick connect fitting, lift the head of the connector back. Insert the end of the PVC hose and release the head of the connector. Ensure connection is secure.

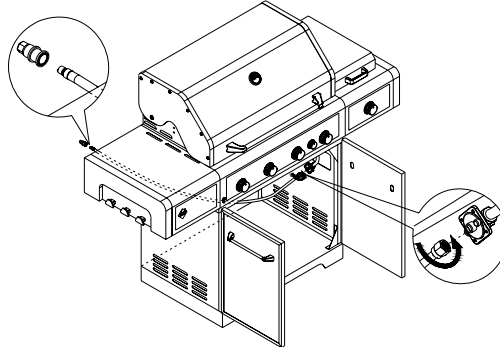

There is a brass adapter for natural gas lines that are pre-regulated. If the gas line is not pre-regulated, remove the brass adapter and connect the regulator directly to the PVC gas hose.



Once conversion is complete, please attach the NG CSA certification sticker to the grill. If you should have any questions regarding natural gas conversion, please contact customer service at 1-800-790-1299.

Natural Gas Conversion for Model# 720-0691A

WARNING: IMPORTANT! BEFORE LIGHTING...

Inspect the gas supply hose prior to turning the gas "ON". If there is evidence of cuts, wear, or abrasion, it must be replaced prior to use. Do not use the grill if the odor of gas is present. Only the pressure regulator and hose assembly supplied with the unit should be used.

Never substitute regulators and hose assembly for those supplied with the grill. If a replacement is necessary, contact the manufacturer for proper replacement. The replacement must be that specified in the manual.

WARNING: Always keep your face and body as far away from the burner as possible when lighting.

TO LIGHT THE MAIN BURNER

Make sure all knobs are "OFF" then turn on the gas. Always keep your face and body as far from the grill as possible when lighting.

Your grill has an exclusive patented built-in ignition. The igniter is built into the valve. To ignite each burner simply push and turn the control knobs to the HI setting, you will hear the valve click as it sends a spark to the pilot flame. If the burner does not light wait 5 minutes for any excess gas to dissipate and then retry.

TO MATCH LIGHT THE SIDE BURNER

Hold a lit extended match near the side burner ports, turn the control knob counterclockwise to "IGNITE/HI". Move your hand immediately once the burner is lit. Rotate the control knob to the desired setting.

Do not attempt to light the grill if odor of gas is present. Call for service 1-800-790-1299

FLAME CHARACTERISTICS

Check for proper burner flame characteristics.

Burner flames should be blue and stable with no yellow tips, excessive noise, or lifting. If any of these conditions exist call our customer service line. If the flame is yellow, it indicates insufficient air. If the flame is noisy and tends to lift away from the burner, it indicates too much air.

Each burner is adjusted prior to shipment; however, variations in the local gas supply may make minor adjustments necessary.

TO LIGHT THE SEARING SIDE BURNER

To light the searing side burner, remove any cooking utensils from the burner grate. Push and turn the control knob counterclockwise to the "IGNITE/ON" position. If the burner does not light, turn the control knob to "OFF". If the smell of gas is detected and the igniter is not functioning, immediately turn the control knob "OFF". Allow 5 minutes for any accumulated gas to dissipate. If the side burner igniter is not functioning, see the following section for match lighting.

TO MATCH LIGHT THE GRILL

If the burner will not light after several attempts then the burner can be match lit.

Match light extension rod is located on the inside panel of the door.

If you've just attempted to light the burner with the igniter, allow 5 minutes for any accumulated gas to dissipate. Keep your face and hands as far away from the grill as possible.

Insert a lit match attached to the lighting rod through the cooking grids to the burner.

Press the control knob and rotate left to the HI/ON setting continue to press the knob until the burner ignites.

Burner should light immediately.

If the burner does not light in 4 seconds turn the knob off, wait 5 minutes and try again.



Visually check the burner flames prior to each use, The flames should look like this picture, if they do not, refer to the burner maintenance part of this manual.

Natural Gas Conversion for Model# 720-0691A

Note: Remove all packaging, including straps, before using the grill

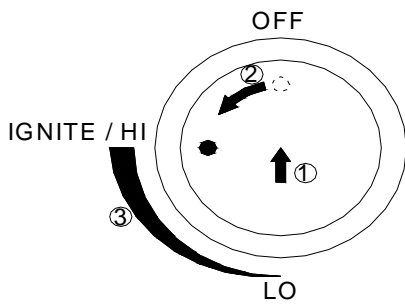
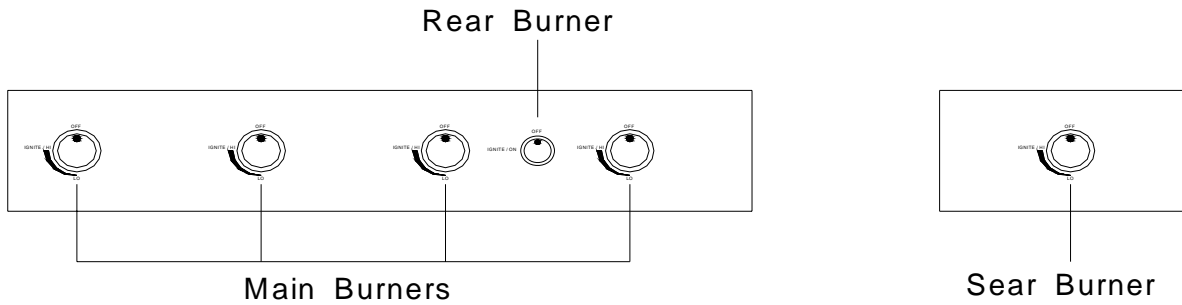

- ① Make sure the lid is open.
- ② Push and turn Main Burner knob slowly to IGNITE/HI. Keep knob pressed in until the burner is lit.
- ③ If burner does not light within 5 seconds, turn the knob to OFF and repeat the lighting instruction.
- ④ If burner does not light up after step 3, turn the knob to OFF, wait 5 minutes, and repeat the lighting procedure or light by match.

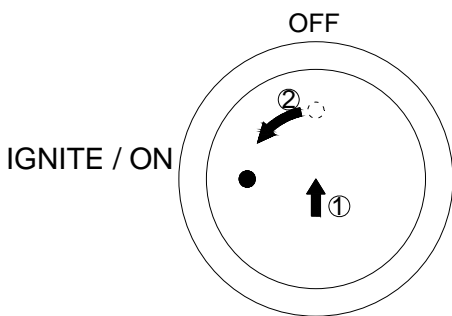

- ① Make sure the lid is open.
- ② Push and slowly turn the Rear Burner knob to IGNITE/ON position. Keep knob pressed in until the burner is lit. Once it is lit, continue to press and hold for another 15 seconds to ensure the burner stays lit.
- ③ If burner does not light within 5 seconds, turn the knob to OFF position and repeat the lighting procedure.
- ④ If burner fails to light after step 3, turn the knob to OFF position, wait 5 minutes, then repeat the lighting procedure or light by match.

Natural Gas Conversion for Model# 720-0691A

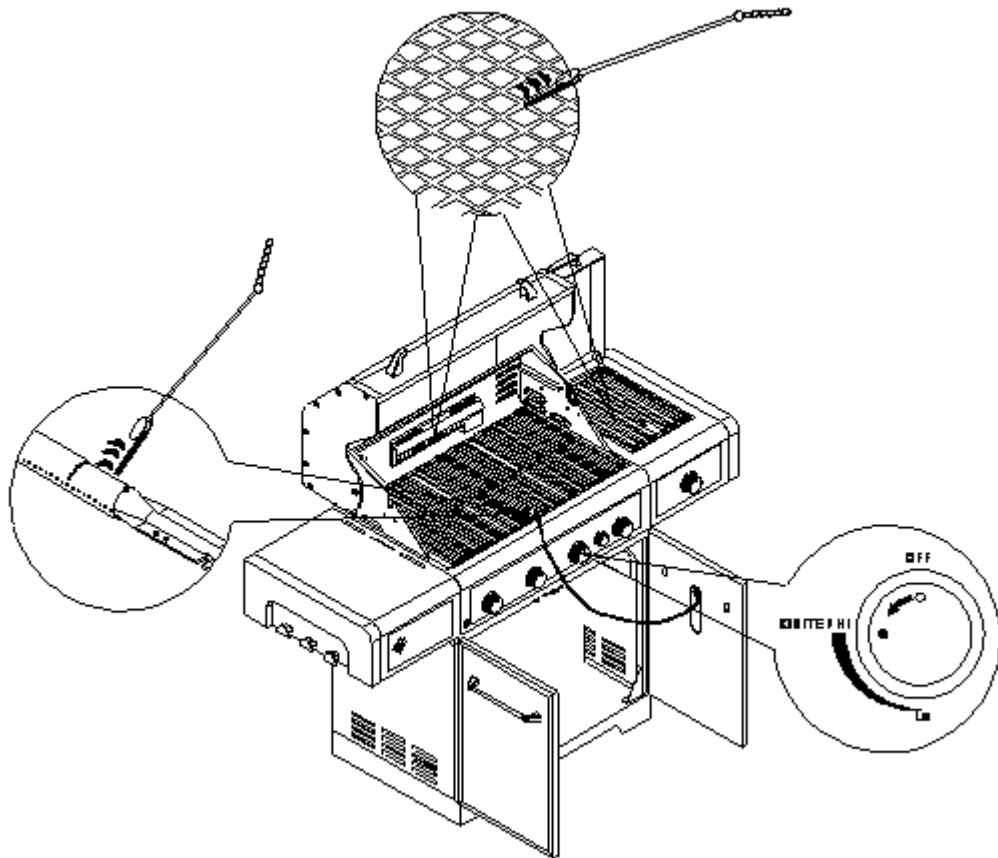

Match light

1. If the burner will not light after several attempts then the burner can be match lit, before using the match allow 5 minutes for any accumulated gas to dissipate.
2. Clip a paper match on one end of the lighting rod.
3. Light match.
4. Hold lighting rod and insert lighted match right next to the burner ports or ceramic file.
5. Push and turn the designated control knob to IGNITE/HI.
6. Burner should ignite immediately.