

This Owner's Manual is provided and hosted by [Appliance Factory Parts](#).

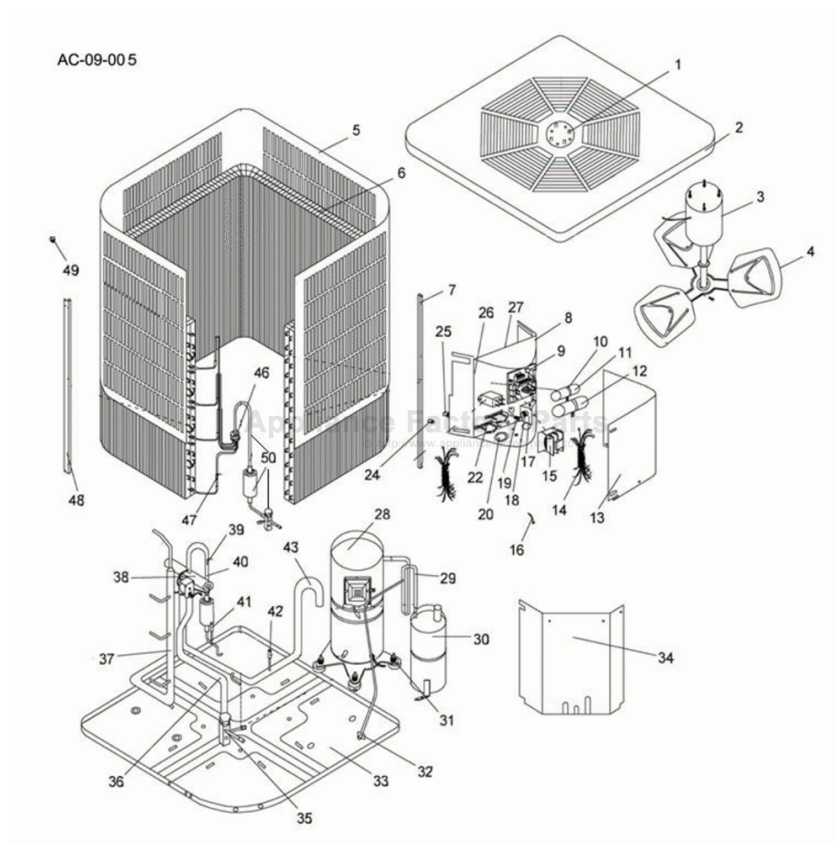

Haier HR42A1VAR Owner's Manual

[Shop genuine replacement parts for Haier HR42A1VAR](#)



[Find Your Haier HVAC Parts - Select From 721 Models](#)

----- Manual continues below -----

HAIER

COMMERCIAL AIR CONDITIONER

Service Manual

Part # AC-8888-107

HAIER TRADING COMPANY, LLC
www.haieramerica.com



Commercial Air Conditioning

SERVICE MANUAL



Mode-

HR18A1VAR HR24A1VAR

HR30A1VAR HR36A1VAR

HR42A1VAR HR48A1VAR

HR60A1VAR

● Features

- High efficiency design
- Hermetic compressor design
- Haier Hi-Efficiency fin and copper tube design
- Compact design of outdoor unit
- Convenient for installation and maintenance
- Heat pump, 10SEER

CONTENTS

1. DESCRIPTION OF PRODUCTS & FEARURES.....	3
2.PHYSICAL AND ELECTRICAL SPECIFICATIONS.....	5
3.SAFETY PRECAUTION.....	9
4.SYSTEM COMPONENTS AND FUNCTIONS	9
5.ELECTRICAL CONTROL DEVICES.....	11
6.APPLICATION.....	12
7.REFRIGERANT DIAGRAM	13
8. INSTALLATION INSTRUCTIONS.....	14
9.MAINTENANCE INSTRUCTIONS.....	31
10.SERVICE AND TROUBLESHOOTING	32
11.WIRING DIAGRAMS.....	43
12. EXPLOSIVE DIAGRAM AND SPARE PARTS LIST	44

1. DESCRIPTION OF PRODUCTS & FEARURES

1.1 Air conditioner

This manual discusses “split” central air conditioning ,indoor coils, .”Split” refers to the physical location of the major air conditioning components that are not in the same box ,as in a “packaged” system.

10 SEER(“Seasonal Energy Efficiency Ratio”), families of split system air conditioning are manufactured to rigid standards of quality and performance. They meet or exceed the standards imposed by efficiency legislated and therefore represent both good value today and for years to come. The current families of the air conditioning now use scroll and reciprocating compressors. This gives the air conditioning a much more durable compressor needing less external protection while increasing the unit efficiency in cooling mode.

1.2 NOMENCLATURE FOR MODEL NUMBE

Example

H	C	24	A	1	V	A	R
Haier	System type	Nominal capacity in (1000) Btuh	SEER designation	Design series	Electric Designation	Body style	Reserved
Brand symbol :H: Haier	C: Air Conditioner; R: Heat Pump	24: 24000BTU/h; 60: 60000BTU/h	A:10SEER; B:11SEER; C:12SEER; D:13SEER E:14SEER; F:15SEER; G:16SEER; H:17SEER I:18SEER	1: 1st Generation; 2:2nd Generation	Y: 575V-3Ph-60Hz; V:208/230V-1Ph-60 Hz; C:208/230V-3Ph-60 Hz; D:460V-3Ph-60Hz; A:115V,1 Ph,60Hz	A: standard style	

Table 1-1

1.3 ENGINEERING FEATURES:

COPPER TUBE/ALUMINUM FIN COILS Both indoor and outdoor coils are designed to optimize heat transfer, minimize size and cost, and increase durability and reliability.

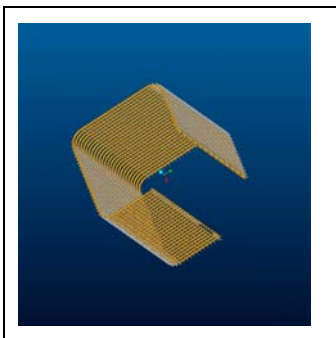

Fig.1-1

CABINETS-Constructed of powder painted and galvanized steel providing protection to the outdoor unit and a durable finish.



Fig.1-2

SERVICE VALVES-Facilitates unit servicing and provides a reliable and safe access to measure unit pressures .

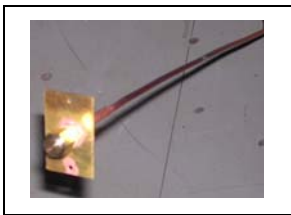

Fig.1-3

FLOWCHECK DISTRIBUTORS-Outdoor units use the Flowcheck Distributor to act as an open check valve in the cooling mode. **BASE PAN**- This deep-drawn and sturdy base keeps the bottom of the coil out of harms way. The base has weep holes to allow the water from rain to flow away from the unit.

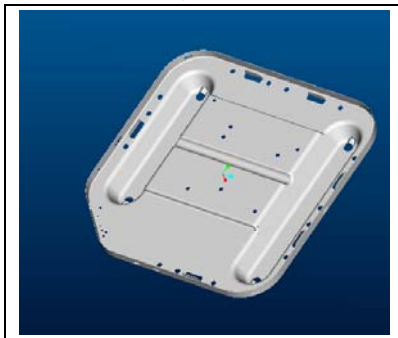

Fig.1-4

ACCESSORIES

LOW AMBIENT CONTROL- This allows low temperature operation in the cooling cycle down to 0 °F, outdoor temperature .This control should be installed in units that operate in cooling in outdoor ambient temperatures below 65°F, and is recommended for all commercial applications.

START COMPONENTS – Offer additional starting torque covering a wide range of voltage and pressure variations .Usually required on reciprocating compressors with flowcheck piston metering .

2.Physical and Electrical Specifications

10 SEER								
Model Number	HP	HR18A1VAR	HR24A1VAR	HR30A1VAR	HR36A1VAR	HR42A1VAR	HR48A1VAR	HR60A1V
Comments		1.5-Ton Outdoor HP	2-Ton Outdoor HP	2.5-Ton Outdoor HP	3-Ton Outdoor HP	3.5-Ton Outdoor HP	4-Ton Outdoor HP	5-Ton Outd HP
Model Status		New Model	New Model	New Model	New Model	New Model	New Model	New Model
Performance								
Indoor Unit Matching with		HB2400VA1M20	HB2400VC1M20	HB3600VA1M20	HB3600VC1M25	HB4200VA1M25	HB4800VA1M25	HB6000VA1M25
Cooling Capacity (Btu/h)		18,000	23,000	28,000	35,000	42,000	46,000	54,000
Net Sensible Capacity (Btu/h)		12960	16560	20160	25200	30240	33120	38880
Net Latent Capacity (Btu/h)		5,040	6,440	7,840	9,800	11,760	12,880	15,120
SEER		10.0	10.0	10.0	10.0	10.0	10.0	10.0
Total Input Watts (Cooling)		2,000	2,600	3,200	4,000	4360	4700	6000
Heating Capacity (Btu/h) (8.3°C)		17,500	21,500	27,000	34,000	41,000	46,000	55,000
Heating COP (8.3°C)		3.0	3.1	3.0	3.1	3.3	3.4	3.2
Heating HSPF		7.0	7.0	7.0	7.0	7.0	7.0	7.0
Total Input Watts (Heating)		1740.0	2000.0	2581.0	3160.0	3594.0	3989.0	4800.0
Outdoor Airflow Rate (CFM)		1850	1850	1950	1950	2700	2900	2900
Electrical								
Voltage - Phase - Frequency (Hz)		208/230 - 1 - 60	208/230 - 1 - 60	208/230 - 1 - 60	208/230 - 1 - 60	208/230 - 1 - 60	208/230 - 1 - 60	208/230 - 1 - 60
Minimum Circuit Amps		10.1	12.9	16.2	19.4	21.2	31.9	37.6
The Maximum Fuse Size (A)		15.0	20.0	25.0	30.0	35	50	60
Compressor								
Type / Maker		Reciprocating	Reciprocating	Reciprocating	Reciprocating	Reciprocating	Scroll	Scroll
Model Number		H29B18UABCA	H29B22UABCA	H29B28UABCA	H29B35UABCA	H20J403ABCA	H20R483ABCA	H20R583ABCA
RLA (Rated Load Amps)		7.4	9.6	11.8	14.4	15.8	24.4	28.9
LRA (Locked Rotor Amps)		48.0	60.0	73	86.0	90	140	165
Input Watts		1900	2105	2600	3030	3510	4200	5080
Internal Overload Protection		Yes	Yes	Yes	Yes	Yes	Yes	Yes
Crankcase Heater		Yes	Yes	Yes	Yes	Yes	Yes	Yes

Filter Dryer			Standard	Standard	Standard	Standard	Standard	Standard
Full, Reusable Service Valves			Yes	Yes	Yes	Yes	Yes	Yes
Easy Service Access			Yes	Yes	Yes	Yes	Yes	Yes
Corrosion Resistant Outside Screws			Yes	Yes	Yes	Yes	Yes	Yes
Accessories								
Room Thermostat			No	No	No	No	No	No
Start Assist Kit			No	No	No	No	No	No
Low Ambient Kit			Optional	Optional	Optional	Optional	Optional	Optional
Compressor Time Delay			Optional	No	No	No	No	No
Compressor Blanket Kit			No	No	No	No	No	No
Fan Delay Kit (Note 1)			No	No	No	No	No	No
Piston			YES	YES	Yes	YES	YES	YES
Dimensions and Installation								
Unit Dimensions (inches)								
	Depth		23	23	23	23	30 1/4	30 1/4
	Width		23	23	23	23	30 1/4	30 1/4
	Height		27 3/4	27 3/4	31 1/2	31 1/2	31 1/2	31 1/2
	Cubic Volume (Cu. Ft)		8.50	8.50	9.80	9.80	16.7	16.7
Refrigerant Line								
	Liquid Line Dimension (In)		3/8	3/8	3/8	3/8	3/8	3/8
	Vapor Line Dimension (In)		5/8	5/8	3/4	7/8	7/8	7/8
	Max Refrigerant Line Length (Ft)		115	115	115	115	115	115
	Max Vertical Distance (Ft)							
		Outdoor above Indoor Unit	70	70	70	70	70	70
		Indoor above Outdoor Unit	50	50	50	50	50	50
Service Valves			Re-usable	Re-usable	Re-usable	Re-usable	Re-usable	Re-usable
Refrigerant Connection Type			Sweat	Sweat	Sweat	Sweat	Sweat	Sweat
Metering device (Piston size)Cooling /heating			Orifice (074/059)	Orifice (078/068)	Orifice (078/068)	Orifice (081/074)	Orifice(091/078)	Orifice(097/078)
Refrigerant: R22 / Charge: g/Oz			2000 / 70.67	2520 /89.05	2750 / 97.17	2850 /100.71	3900 /137.81	4000 / 141.42
Min Clearances			10" sides/18" service	10" sides/18" service	10" sides/18" service	10" sides/18" service	10" sides/18" service	10" sides/18" service
Weight (lbs)								
	Net		139.0	136	143	145	216	216
	Shipping		158	155.0	167	169	238	240
Agency Approvals								
Performance Certification			ARI	ARI	ARI	ARI	ARI	ARI
Safety Approvals			UL/cUL	UL/cUL	UL/cUL	UL/cUL	UL/cUL	UL/cUL

3.SAFETY PRECAUTIONS

CAUTION: To ensure proper installation and operation, completely read all instructions prior to attempting to assemble ,install ,operate, maintain or repair the product.

WARNING:THE MANUFACTURER’S WARRANTY DOES NOT COVER ANY DAMAGE OR DEFECT TO THE AIR CONDITIONER CAUSED BY THE ATTACHMENT OR USE OF ANY COMPONENTS,ACCESSORIES OR DEVICES(OTHER THAN THOSE AUTHORIZED BY THE MANUFACTURER)INTO,ONTO OR IN CONJUNCTION WITH THE HEAT PUMP.BE AWARE THAT THE USE OF UNAUTHORIZED COMPONENTS,ACCESSORIES OR DEVICES MAY ENDANGER LIFE AND PROPERTY.THE MANUFACTURER DISCLAIMS ANY RESPONSIBILITY FOR SUCH LOSS OR INJURY RESULTING FROM THE USE OF SUCH UNAUTHORIZED COMPONENTS,ACCESSORIES OR DEVICES.

- Always use good industry-recognized service practices in the maintenance, adjustment and repair of the products covered in this manual to protect the technician and the customer.
- Always wear safety glasses when handling refrigerant and brazing materials.
- Follow the manufacturer’s instructions when making repairs and installing replacement parts and assemblies.
- Use only authorized parts to ensure that the equipment operates at the efficiency and useful life that the manufacturer built into the product.

4.SYSTEM COMPONENTS AND FUNCTIONS

This section describes the various air conditioning components, their purpose and operation. This section is only a guide and does not consider all components that could be found on an air conditioner in the field.

COMPRESSORS

The heart of any refrigerant system is the compressor .It is a pump causing refrigerant to flow. There are several different types of compressors ,but all use electricity to turn an electric motor to drive a pump.

Air conditioners use two types of compressors. The first is the enhanced reciprocating compressor .It operates with an offset crankshaft and pistons, and resembles an internal combustion engine. The driving force is supplied by an electric motor turning the crankshaft and forcing the pistons into the cylinders where valves control the flow of refrigerant. The valves provide a seal between high and low pressure sides of the system. If the valves are damaged ,the compressor’s reliability, efficiency and effectiveness are reduced or eliminated.



Reciprocating type compressor



Scroll type compressor

Fig.4-1

Generally, liquid refrigerant is suspected if valve damage occurs. Some compressors can tolerate the presence of small amounts of liquid refrigerant in the returning gas, but none are designed to withstand it continually. Returning refrigerant cools the compressor motor. Surrounding the motor with low pressure gas gives it the name of “low-side” shell compressor.

The scroll compressor used a helix (similar in shape to a snail shell) to move refrigerant. When placed within a similar stationary helix, the moving helix rotates so that the space between the two constantly decreases as the gas moves toward the center of the Scrolls. The returning refrigerant gas first cools the motor, then flows into the suction intake of the compressor scroll. The discharge gas leaves from the center of the helix and exits the compressor. The lower part of the shell should be cool to the touch.

All current single phase units use two types of compressors .In construction, the two compressors are quite different. In function they are identical. Scroll units do not need start components or crankcase heaters. The reciprocating compressor may need both. Both types benefit from using a time-delay. This

prevents thermostat short cycling and momentary power interruptions ,from damaging the compressor. Both compressor types are protected against over-current and over-temperature conditions. Some scroll compressors have an additional thermostat mounted externally in series electrically with the contactor coil.

FAN AND BLOWER MOTORS

The outdoor unit of split systems contains an outdoor fan motor. These PSC(permanent split capacitor)motors are single speed motors driving a propeller fan. The motor mounts to the unit top with the shaft down. The fan pulls outdoor air through the outdoor coil.



Fan motor
Fig.4-2

To access the motor, carefully remove the unit top to avoid damaging the blade or motor.

WARNING: WHEN SERVICING THIS MOTOR,TURN OFF THE ELECTRICAL POWER TO THE OUTDOOR UNIT. The indoor air handler also has a motor . This blower motor is a PSC motor and usually has more than one fan speed.



Fan and motor assembly
Fig4-3

METERING DEVICES

Flow-Check Pistons

One air conditioning metering device is the flow-check piston. It has two functions. First it acts as a refrigerant metering device controlling refrigerant flow into the evaporator. Second, it acts as an open check valve when refrigerant flows in the opposite direction.

When refrigerant enters the device from the nut end, the piston seats and forces all refrigerant through the center of the piston. It functions as a metering device controlling the amount of refrigerant flow. With flow in the opposite direction, pressure moves the piston off the seat and liquid refrigerant flows around the piston.

PROPER MATCH OF UNIT AND PISTON SIZES

Split air conditioning indoor and outdoor units must be properly matched in accordance with the manufacturer’s specification sheets and installation manuals.

Combinations for indoor and outdoor units using a distributor and flowcheck are shown in the application table 6-2.

Using too small a piston starves the coils of refrigerant .A piston that is too large floods coils. Mismatching indoor and outdoor units of split systems affects performance, efficiency, charging and reliability.



Distributor assy
Fig.4-4

REFRIGERANT CIRCUIT

There are two types of outdoor coil circuiting: single and multi-circuited. The 10 series are all multi –circuits.

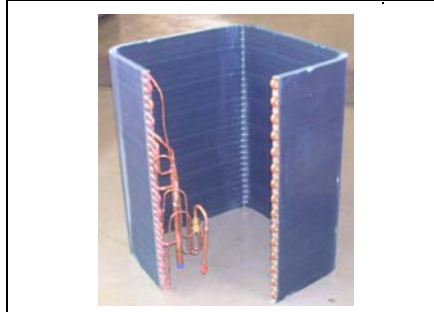

Fig.4-5

SERVICE VALVES

There are two types of service valve used on the air conditioning .They are the service port valve or “Schrader valve” and the refrigerant line valve. The Schrader valve is like a tire valve in an automobile. The stem or core is removable with a flexible seal at its base held closed with a spring. Schrader valves allow a technician to connect gages to the system with a minimum loss of charge. Use a cap with an inner seal to prevent leakage and keep dirt and moisture out..

The refrigerant control valve lets the system be isolated into two separate sections. In split system, These valves hold the charge in the outdoor section from the time of manufacture until the unit is connected to the indoor section by the installer.

5.ELECTRICAL CONTROL DEVICES

THERMOSTATS

Thermostats are the most obvious control in the air conditioning ,since these controls are accessible by the consumer. Contact the local distributor for information on part numbers of various manual changeover, auto changeover and set-back thermostats or see the thermostat and subbase selection information found in the wiring diagram booklet.

In the cooling mode, the thermostat calls for cooling by energizing the compressor contactor and the indoor blower control. The indoor blower can operate continuously by setting the thermostat subbase fan switch to the “ON” position.

PROTECTION DEVICES

Protection for the unit begins with the installation of appropriate fuses or circuit breakers by the installing contractor. Breaker or fuse size is governed by local codes and the National Electrical Code. Current requirements for each unit are found in the unit specifications.

OVERLOADS AND LIMITS

Overloads protect against over-current or over-temperature conditions. Those located in the outdoor unit include the automatic reset internal overload in the fan motor and the compressor automatic reset internal overload. Such controls are not serviceable but their operation may influence service troubleshooting .For example ,the compressor internal overload may stay open for several hours .A technician may incorrectly diagnose an open compressor winding.

There are similar overloads in the indoor air handling portion with the electric resistance heaters. The indoor blower motor has an internal overload. The electric elements use two types of protectors ,both replaceable. Some electric heat section use fusible links. They are a one time over-temperature protector and must be replaced upon opening. Limit controls are thermal discs that automatically reset .Normally, limit open and stop a heat rise before the fusible links open.

NOTE: Never disconnect or wire around a safety device .First determine why it opened, then replace it with a properly rated part.

HIGH PRESSURE CUT OUT SWITCH (optional)

The high pressure cut-out is a pressure activated switch. It opens an electrical circuit when the refrigerant pressure exceeds a pre-determined limit of 440 to 460 p.s.i.g. This switch can restore

automatically when pressure value becomes normal.



Fig.1-10

RELAYS

Relays provide control switching .The voltages controlled may be either low(24V.A.C.)or line voltage. It is usually 24 volts. Contact voltage may be either low or line voltage.

COMPRESSOR CONTACTOR

The compressor contactor is a large relay. The coil uses 24 volts but the contacts carry line voltage .The contactor controls compressor and the outdoor fan operation. Some contactor use single pole contacts ,while others use 2-pole or 3-pole contacts.

Single-pole contacts break power to only one side of the compressor and outdoor fan .The other side remains hot with voltage. The 2-pole or 3-pole contactor breaks power to all sides of the compressor and outdoor fan.

CAUTION:WITH A SINGLE POLE CONTACTOR,ONE SIDE OF A 240 V.A.C.CIRCUIT IS ALWAYS HOT.THIS MEANS ALL WIRING IN THE HIGH VOLTAGE CIRCUIT MAY HAVE A POTENTIAL OF 120 V.A.C.TO GROUD.BEFORE SERVICING THE UNIT ALWAYS TURN OFF POWDER AT THE UNIT DISCONNECT SWITCH.

OPTIONAL RELAYS AND KITS

A Time-Delay in the compressor contactor low-voltage circuit allows time for system pressure to equalize before re-starting the compressor.

This relay user solid state circuitry to measure the time since the power was interrupted. It is set for up to 3 minutes .It is not field adjustable. It is a delay on break timer.

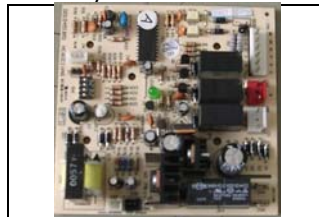

Compressor relay PCB

Fig.5-1

START KITS(OPTIONAL)

This special relay uses the EMF generated by the compressor start windings to take a start capacitor out of the circuit. The relay and its companion capacitor can start the compressor at low voltages and against higher pressure, such as those caused by non-bleed port expansion valves.

Start kits are not normally required with scroll compressors. The operating characteristics of the scroll compressor make a start kit unnecessary.

6.APPLICATION

Before specifying any air conditioning equipment, a survey of the structure and a heat gain calculation must be made. A heat gain calculation involves identifying all surfaces and openings that gain heat from the surrounding air and quantifying that heat gain. It also calculates the extra heat load caused by sunlight and by humidity removal. These factors must be considered before selecting an air conditioning system to provide year round comfort. The Air Conditioning Contractors of America (ACCA) J Manual method of load calculation is one recognized procedure for determining the cooling load.

The cooling load calculation determines the unit size. There are two capacities that enable the equipment to provide comfort. The first is sensible capacity. How much sensible heat can the unit remove? Sensible heat is the heat energy measured on the dry bulb thermometer.

The second form of heat is called latent or hidden heat. This is heat held in the humidity in the air. Removing this heat does not affect a thermometer. However, removing the heat held in the moisture in the air greatly increase comfort. A properly sized unit removes both forms of heat, producing a comfortable living space. An oversized system cycles on and off too quickly and does not properly remove humidify , producing an uncomfortable living space. Select the indoor and outdoor equipment combination based on the manufacturer’s engineering data.

After the proper equipment combination has been selected, satisfying both sensible and latent conditioning requirements, the system must be properly installed. Only then can the unit provide the comfort the manufacturer built into it.

There are several factors that installers must consider.

- Outdoor unit location
- Proper equipment evacuation
- Outdoor unit refrigerant charge
- Indoor unit air flow
- Indoor unit blower speed
- Supply and return air duct design and sizing
- System air balancing
- Diffuser and return air grille location and sizing

Unit Dimensions

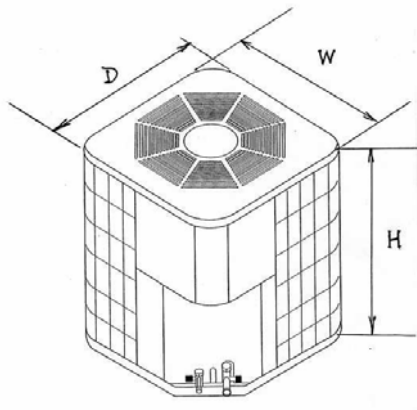

Model:HR18-60A1VAR

----A1VAR	HR18	HR24	HR30	HR36	HR42	HR48	HR60
D	23[585]	23[585]	23[585]	23[585]	30 1/4[770]	30 1/4[770]	30 1/4 [770]
W	23[585]	23[585]	23[585]	23[585]	30 1/4[770]	30 1/4[770]	30 1/4 [770]
H	27 3/4[702]	27 3/4[702]	31 1/2[802]	31 1/2[802]	31 1/2[798]	31 1/2[798]	35 1/2[898]

[] Designates Metric Conversions
Table 6-1

piston sizes:

Note: the piston placed in the outdoor unit packaging box is used for indoor unit when cooling.

Outdoor unit	Indoor coil model	Piston Size (Installed in outdoor)	Piston Size(placed in package bag)
HR18A1VAR	HB2400VA1M20	0.059	0.074
HR24 A1VAR	HB2400VC1M20	0.068	0.078
HR30 A1VAR	HB3600VA1M20	0.068	0.078
HR36A1VAR	HB3600VC1M25	0.074	0.081
HR42A1VAR	HB4200VA1M25	0.078	0.091
HR48A1VAR	HB4800VA1M25	0.081	0.097
HR60A1VAR	HB6000VA1M25	0.081	0.099

Table 6-2 Piston size

The air distribution system has the greatest effect. The duct system is totally in the control of the contractor. The industry can only recommend the correct procedure.

The correct air quantity is critical on air conditioning system. Proper operation ,efficiency, compressor life and humidity control depend on the correct balance between indoor load and outdoor unit capacity .High indoor air flow increases the possibility of high humidity problems in cooling. Low indoor air flow reduces total capacity, and causes coil icing. Serious harm can be done to the compressor in either condition.

Air conditioning requires a specified air flow. Each ton of air conditioning requires 400 cubic feet of air per minute(**400CFM/TON**).

Duct design and construction should be carefully done. System performance can be lowered dramatically through bad planning or workmanship. In cooling ,a hot attic can cause a temperature gain of 3° in the return duct and 4° in the supply duct. This can reduce the cooling capacity of an air conditioning system by as much as 30%.This means a loss of almost one ton of cooling capacity from a three ton system.

Air leakage of only 3% in a return duct can cause a 5% loss in system capacity. 3% leakage on a three ton system is only 30 CFM. Two or three unsealed joints can cause this leak. Sealing the return and supply ducts pays dividends in increased system capacity and lower operating costs.

Effective duct insulation is essential to prevent loss of capacity and sweating ducts in the cooling mode. Duct systems installed in the conditioned space can be left uninsulated , but a dense 1/2” fiberglass duct liner reduces blower and air noises, and prevents sweating ducts when humidity levels are high.

Supply and return duct systems in attics and crawl spaces require a minimum 1” of dense duct liner or 2” fiberglass wrap with a sealed vapor barrier. A leaky vapor barrier results in duct sweating, causing wet insulation.

Wet insulation does not insulated .Heat transfer through poorly insulated systems can result in over 50% loss in operating capacity. Sweating ducts also promote rusting ducts resulting in premature duct failure. Other duct materials have been successfully used. Carefully follow the duct manufacturers’ installation instructions. The duct system is only as good as the planners and installers construct.

Air supply diffusers must be selected and located carefully. They must be sized and positioned to deliver treated air along the perimeter of the space. If they are too small for their intended air flow the become noisy. If they are not located properly they cause drafts on the occupants in the rooms. Return air grilles must be properly sized to carry air back to the blower. If they are too small they also cause noise. The installers should balance the air distribution system to ensure proper air flow to all rooms in the home. This ensures a comfortable living space.

7. Refrigerant system diagram refer figure below

8. INSTALLATION INSTRUCTIONS

! WARNING

These instructions are intended as an aid to qualified, licensed service personnel for proper installation, adjustment and operation of this unit. Read these instructions thoroughly before attempting installation or operation. **Failure to follow these instructions may result in improper installation, adjustment, service or maintenance possibly resulting in fire, electrical shock, property damage, personal**

Figure 7 Heat Pump Refrigerant Circuit

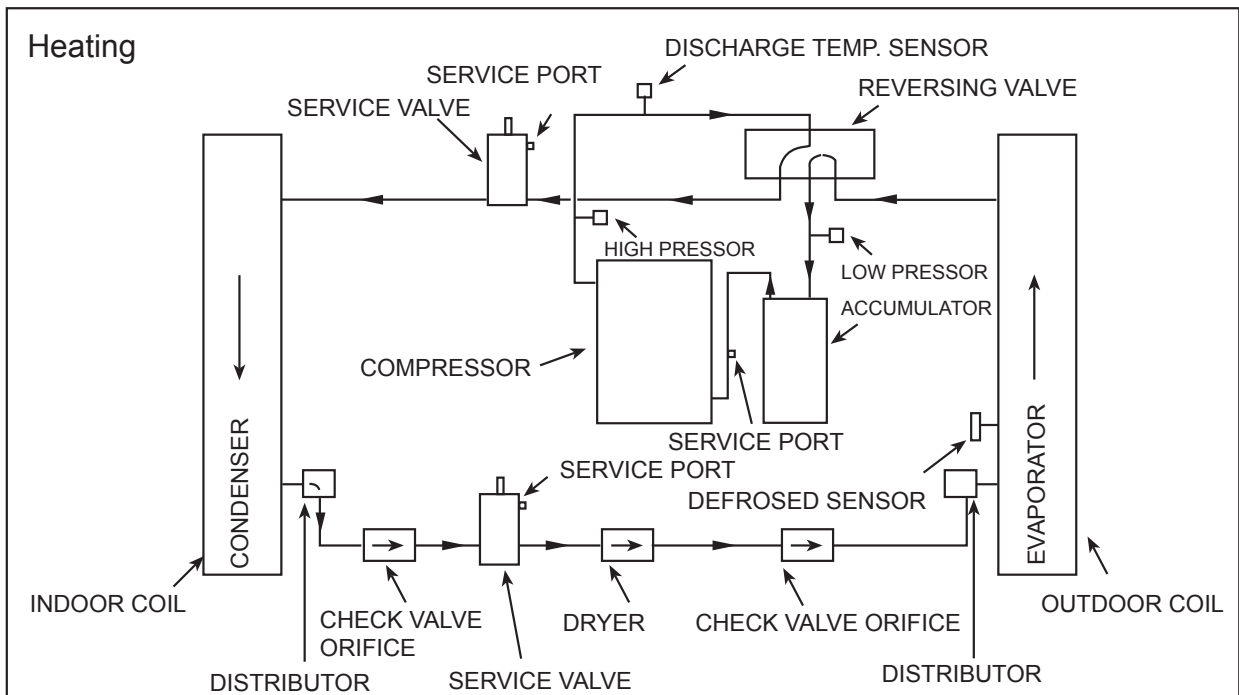
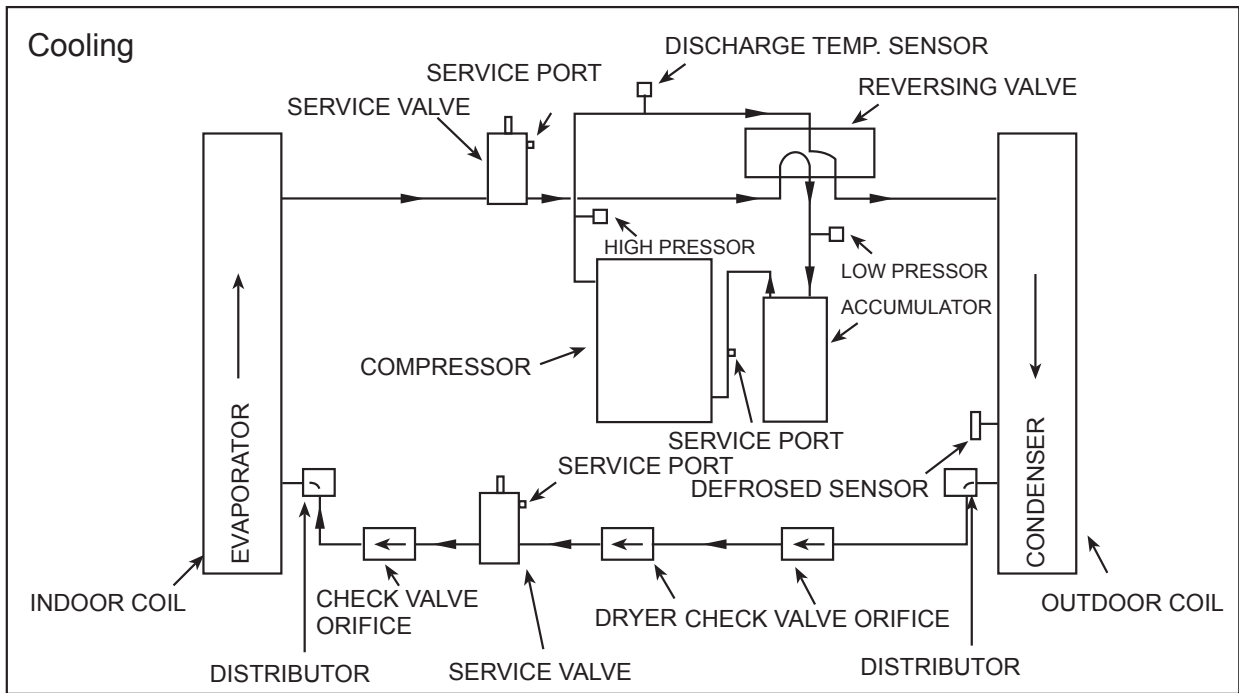

injury or death.

This product is designed and manufactured to permit installation in accordance with National Codes. **It is the installer's responsibility to install the product in accordance with National Codes and/or prevailing local codes and regulations.** The manufacturer assumes no responsibility for equipment installed in violation of any codes or regulations.

The United States Environmental Protection Agency (EPA) has issued various regulations regarding the introduction and disposal of refrigerants in this unit. Failure to follow these regulations may harm the environment and can lead to the imposition of substantial fines. Because these regulations may vary due to the passage of new laws we suggest that any work on this unit be done by a certified technician. Should you have any questions please contact the local EPA office.

The manufacturer's warranty does not cover any damage or defect to the air conditioner caused by the attachment or use of any components, accessories or devices (other than those authorized by the manufacturer) into, onto, or in conjunction with the air conditioner. **You should be aware that the use of unauthorized components, accessories or devices may adversely affect the operation of the air conditioner and may also endanger life and property.** The manufacturer disclaims any responsibility for such loss or injury resulting from the use of such unauthorized components, accessories or devices.

Attach the service panel to the outdoor unit securely. If the service panel is not attached securely, it could result in a fire or an electric shock due to dust, water, etc.

These instructions are intended as an aid to qualified, licensed service personnel for proper installation, adjustment and operation of this unit. Read these instructions thoroughly before attempting installation or operation. **Failure to follow these instructions may result in improper installation, adjustment, service or maintenance possibly resulting in fire, electrical shock, property damage, personal injury or death.**

This product is designed and manufactured to permit installation in accordance with National Codes. **It is the installer's responsibility to install the product in accordance with National Codes and/or prevailing local codes and regulations.** The manufacturer assumes no responsibility for equipment installed in violation of any codes or regulations.

The United States Environmental Protection Agency (EPA) has issued various regulations regarding the introduction and disposal of refrigerants in this unit. Failure to follow these regulations may harm the environment and can lead to the imposition of substantial fines. Because these regulations may vary due to the passage of new laws we suggest that any work on this unit be done by a certified technician. Should you have any questions please contact the local EPA office.

The manufacturer's warranty does not cover any damage or defect to the air conditioner caused by the attachment or use of any components, accessories or devices (other than those authorized by the manufacturer) into, onto, or in conjunction with the air conditioner. **You should be aware that the use of unauthorized components, accessories or devices may adversely affect the operation of the air conditioner and may also endanger life and property.** The manufacturer disclaims any responsibility for such loss or injury resulting from the use of such unauthorized components, accessories or devices.

Attach the service panel to the outdoor unit securely. If the service panel is not attached securely, it could result in a fire or an electric shock due to dust, water, etc.

8.1 OUTDOOR UNIT INSPECTION

This product has been inspected at the factory and released to the transportation agency without known damage. Inspect exterior of carton for evidence of rough handling in shipment. Unpack carefully. If damage is found, report immediately to the transportation agency.

8.2 EQUIPMENT PROTECTION FROM ENVIRONMENT

The metal parts of the unit may be subject to rust or corrosion in adverse environmental conditions. This oxidation could shorten the unit life. Salt spray or mist in seacoast areas, sulphur or chlorine from lawn watering systems and various chemical contaminants from industries such as paper mills and petroleum refineries are especially corrosive. If the unit is to be installed in an area where contaminants are likely to be a problem, special attention should be given to the equipment location and exposure.

Avoid having lawn sprinkler heads spray directly on the unit cabinet.

In coastal areas, locate the unit on the side of the building away from the waterfront.

Shielding provided by fence or shrubs may give some protection.

Regular maintenance will reduce the buildup of contaminants and help to protect the unit's finish.

! WARNING - Disconnect all electrical power to the unit before servicing. Disconnect power to both the indoor and outdoor units. NOTE: There may be more than one electrical disconnect switch. Failure to shut off power can cause electrical shock resulting in personal injury or death.

Frequent washing of the cabinet, fan blade and coil with fresh water.

Regular cleaning and waxing of the cabinet with good automobile polish.

A good liquid cleaner may be used several times a year to remove matter that will not wash off with water.

The best protection is frequent cleaning, maintenance and minimal exposure to contaminants.

8.3 INSTALLATION

These units are designed for outdoor installations. They can be mounted on a slab or rooftop. It is important to consult your local code authorities at the time the first installation is made.

Check following points before attempting any installation:

Structural strength of supporting members.

Clearances and provision for servicing.

Power supply and wiring.

Location for minimum noise, where operating sounds will not disturb owner or neighbors.

Location where there is no risk of combustible gas leakage.

Location where external water drainage cannot collect around the unit.

Location where roof runoff water does not pour directly on the unit. Provide gutter or other shielding at roof level. Don't locate unit in an area where excessive snow drifting may occur or accumulate.

Provide a level concrete slab. To prevent transmission of noise or vibration, slab should not be connected to building structure. Some sort of sound-absorbing material should be placed between the condenser and the slab. A good material to use is rubber and cork pad.

For rooftop application, make sure the building construction can support the weight and that proper consideration is given to the weather-tight integrity of the roof. The condensing unit contains moving parts and can vibrate. Therefore, sound is also a consideration in rooftop applications.

! WARNING - Install the unit securely in a place that can bear the weight of the unit. When installed in an insufficiently strong place, the unit could fall causing injury.

8.4. UNIT CLEARANCES

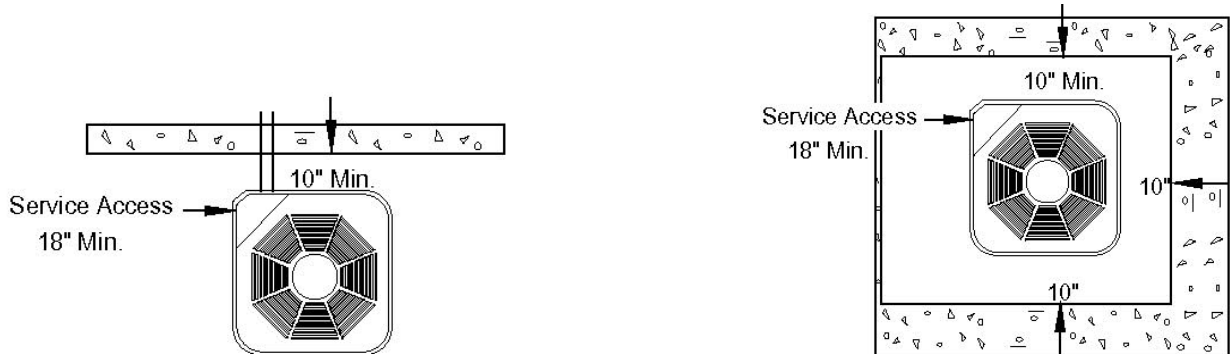

Fig. 8.--1

The minimum clearances for the unit are illustrated in **Fig. 8--1**. Condenser air enters from three sides. Air discharges upward from the top of the unit. Refrigerant tube and electrical connections are made from the service access area. The most common application will find the unit best located about 10" from back wall with connection side facing the wall. This application minimizes exposed tubing and wiring, minimizing the space for youngsters to run around the unit with subsequent damage to the tubing or wiring.

In more confined application spaces, such as corners provide a minimum of 10" clearance on all air inlet sides. For service access to the compressor and control box, allow 18" minimum clearance. Ensure top is unobstructed. If units are to be located under an overhang, there should be a minimum of 36" clearance and provision made to deflect the warm discharge air out from the overhang.

In order to have an unrestricted air flow, owners should be advised to avoid lawn mower discharge toward the unit depositing debris on the fin coil surface reducing the unit efficiency.

8.5 REFRIGERANT PIPING

The refrigerant piping is very important as it affects the proper operation and efficiency of the air conditioning system. Note the following guidelines:

1. The total run ,both vertical and horizontal ,can't be exceed 50 feet
2. Use the next larger liquid line size if the vertical separation exceeds 10 feet.

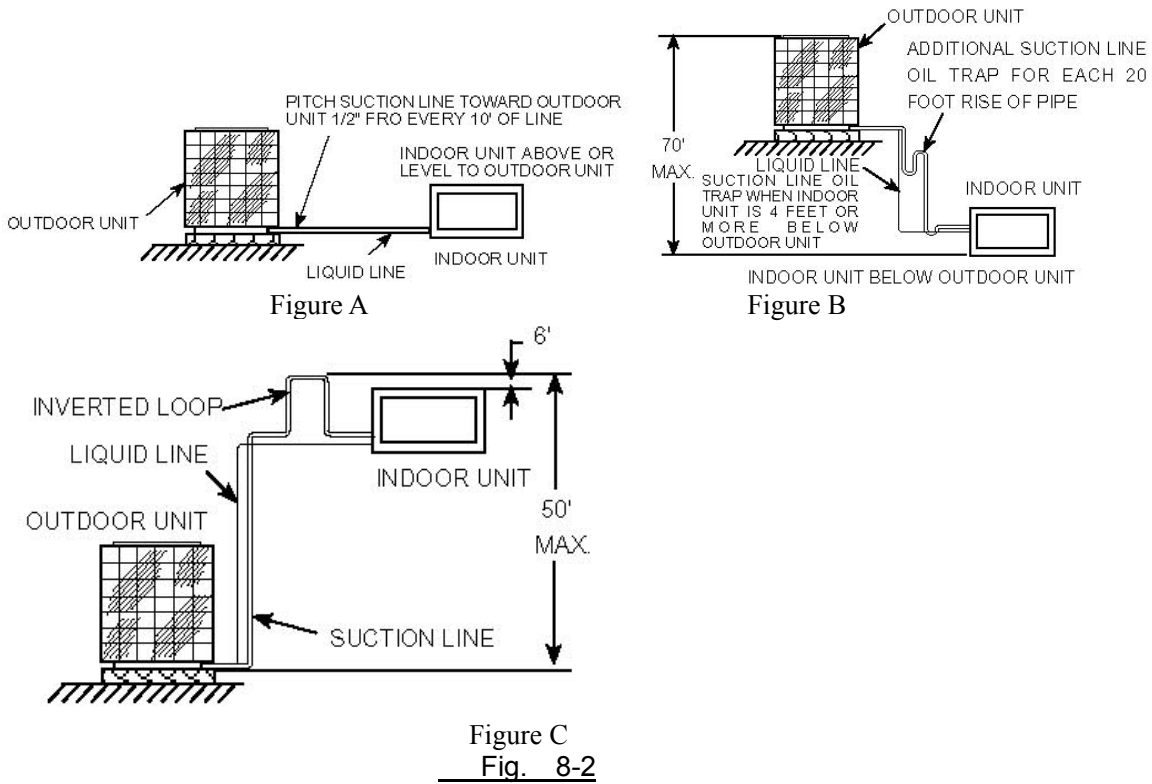

Only refrigeration-grade copper piping (dehydrated and sealed) should be used. **Take extreme care to keep the refrigerant tubing clean and dry prior to and during installation.** If in doubt, blow out the tubing with dry nitrogen to remove any chips or debris before connection. Always keep tubing sealed until it is in place and the connections are to be made.

Refrigerant piping should be as short as possible, with a minimum of elbows or bends, to avoid capacity loss and increased operating costs.

Refrigerant lines must be adequately supported. If metal strapping is used to secure the tubing, do not allow the strapping to directly contact the tubing. Use a closed cell insulation to separate the strapping from the tubing. Do not kink or twist the tubing.

Refrigerant piping should not be installed in a cement slab, as this limits access to the refrigerant should a leak be suspected.

To ensure good oil return to the compressor, it is important to **pitch the horizontal suction line toward the compressor, approximately 1/2" for every 10' of line.**

8.6 Line Insulation

Suction line requires insulation in order to prevent condensation from forming on the piping and to prevent heat gain caused by surrounding air. Generally 3/8" wall thickness of Arm flex or equivalent is satisfactory. In severe application (hot, high humidity areas) greater thickness may be required. Apply the line insulation by sliding it on the sealed tubing before cutting and making connections.

Liquid line does not necessarily need insulation, however, if they are exposed to high ambient temperatures (i.e. kitchen, boiler rooms, hot attics & rooftop surface), then, they should be insulated. Make sure to use the proper size tubing for the liquid line to prevent liquid refrigerant flashing to a vapor within the liquid line.

Do not allow the vapor line and liquid line to touch together. This would cause an

undesirable heat transfer resulting in capacity loss and increased power consumption.

Refrigerant Line Sizing

Check the following table (**Table 8-1**) for correct suction and liquid line sizes for any combination of the unit size and the maximum refrigerant line length.

Refrigerant Line Sizing

Unit Size (Ton)	Refrigerant Line Length (Ft)					
	0 – 24		25 – 49		50 – 74	
	Line Outside Diameter (In)					
	Suction	Liquid	Suction	Liquid	Suction	Liquid
1.5	5/8	3/8	3/4	3/8	3/4	3/8
2.0	5/8	3/8	3/4	3/8	3/4	3/8
2.5	3/4	3/8	3/4	3/8	7/8	1/2
3.0	7/8	3/8	11/8	3/8	11/8	1/2
3.5	7/8	3/8	11/8	3/8	11/8	1/2
4.0	7/8	3/8	11/8	3/8	11/8	1/2
5.0	7/8	3/8	11/8	3/8	11/8	1/2

Table 8-1

The factory charge is sufficient for 25 feet of standard liquid line. For longer or shorter liquid line lengths, adjust the charge as follows:

- 1/4" Line +/- 0.3 oz. Per foot
- 5/16" Line +/- 0.4 oz. Per foot
- 3/8" Line +/- 0.6 oz. Per foot
- 1/2" Line +/- 1.2 oz. Per foot.

Vertical Separation between Indoor and Outdoor Units

Maximum allowable vertical separations between indoor and outdoor units are illustrated in **Fig. 8-2-A and Fig. 8-2-B**. It's 70' when the indoor unit is below the outdoor unit (Fig.8-3-A), and 50' when the indoor unit is above the outdoor unit (Fig. 8-2-B).

To ensure good oil return to the compressor when the indoor unit is below the outdoor unit, suction line oil trap should be used as illustrated in Fig. 8-2-A.

Tubing Connections

! CAUTION - Use extreme caution in removing the caps from the suction and liquid line fittings, as there is pressure present. A fitting is on the liquid line to remove pressure.

! CAUTION - Condensing units are charged with refrigerant. Condensing unit liquid and suction valves are closed to contain the charge within the unit. Do not force the valve stem against the retaining ring. If the valve stem is backed out past the retaining ring, system pressure could force the valve stem out of the valve body and possibly cause personal injury.

Instructions on the field tubing connections and valve opening procedure are as follow:

1. Tubing should be cut square. Make sure it is round and free of burrs at the connecting ends. Clean the tubing to prevent contamination from entering the system.
2. Make sure that both refrigerant shutoff valves at the outdoor unit are closed.

3. Push the tubing into the fitting until it stops. This prevents flux from getting into the system.
4. Remove the cap and Schrader valve core from the service port to protect the valve seals.
5. Wrap a wet rag around the valve stub before brazing.
6. Braze the joints of interconnecting tubing. Flow dry nitrogen into the shutoff valve port and through the tubing while brazing.
7. After brazing quench with a wet rag to cool the joint. Reinstall the Schrader core in the valve, if removed for brazing.
8. Pressurize the lines to 150 psi maximum with dry nitrogen. Check for leaks at all joints with liquid detergent. If a leak is found, repair it after removing the nitrogen. Repeat the process and re-check.
9. Do not purge the lines with refrigerant. Evacuate the lines and indoor coil.

Evacuation

All new installations must be evacuated to a deep vacuum in order that all noncondensable gases and moisture are removed prior to charging the system. Air in a system causes high condensing pressure, which increases power consumption and reduces performance. The presence of moisture in a system can render it inoperable in a very short time. Proper evacuation assures a dry, uncontaminated system. Here is the recommended evacuation procedure:

1. Connect vacuum pump to both liquid and suction valve service ports.
2. Evacuate the interconnecting tubing and indoor coil to 500 microns or less for a minimum of 30 minutes. Close the valve to the vacuum pump and wait 15 minutes. Vacuum should not rise above 800 microns. If unable to obtain 500 microns, or vacuum rises above 800 microns over 15 minutes period, discontinue evacuation, pressurize and check for leaks. Repair any leaks found and repeat the step 2.
3. Close valve to the vacuum pump and stop pump.
4. When sure of a tight, well evacuated system, charge with refrigerant.

8.7 Charging the System

(For systems with capillary tube or fixed orifice metering device)

Before checking the system charge, make sure that the outdoor unit and indoor coil must be an approved match per the unit specification. The indoor conditions should be within 2 F of the desired comfort conditions.

! WARNING - **Do not vent refrigerant to the atmosphere!** It is a violation of federal law to do so. If the refrigerant needs to be removed from a system to correct the charge inside, always use a recovery or recycling device.

! WARNING - To prevent personal injury, **wear safety glasses and gloves when handling refrigerant.**

1. Fully open both shutoff valves.
2. Connect service gage manifold to the valve service ports, being sure to evacuate lines.
3. Startup the system. Run system at least 10 minutes to allow pressure to stabilize.
4. Temporarily install thermometer on suction (large) line near condensing unit. Be sure of good contact between thermometer and line. Wrap thermometer with insulating material to assure accurate reading.
5. Refer to **Table 8-2** for proper system superheat. Add charge to lower superheat. Remove charge to raise superheat. Carefully remove gage lines.

System Superheat					
Ambient Temperature At Condenser Inlet (°F)	Return Air Temperature (°F)				
	65	70	75	80	85
60	17	25	30	33	37
65	13	19	26	32	35
70	5	14	20	28	32
75	5	10	17	25	29
80		5	12	21	26
85		5	10	17	20
90			7	12	18
95			5	5	5
100				5	5

Table 8-2: System charging table by superheat

8.8.ELECTRICAL WIRING

! WARNING –

A means of strain relief must be installed to this appliance at the electrical service entrance. Make sure that interconnecting wires between indoor and outdoor units meet the standards, codes and regulations. Incomplete connection or fixing of the wire could result in a fire.

A means of strain relief must be installed to this appliance at the electrical service entrance.

Do not use intermediate connection of the power cord or the extension cord and do not connect many devices to one AC outlet. It could cause a fire or an electric shock due to defective contact, defective insulation, exceeding the permissible current, etc.

Perform electrical work according to the installation manual and be sure to use an exclusive circuit. If the capacity of the power circuit is insufficient or there is incomplete electrical work, it could result in a fire or an electric shock.

Ground the unit. Do not connect the ground to a gas pipe, water pipe, lighting rod or telephone ground. Defective grounding could cause an electric shock.

Electrical installation will consists of power supply wiring to the condensing unit and control wiring between thermostat, indoor unit and the condensing unit. All wiring must be in accordance with National Electrical Code and/or local ordinances that may apply.

(See unit wiring diagram furnished with this instruction).

The condensing unit rating plate and the tables of "Physical and Electrical Specifications / Outdoor Units" (Table 2-1 and 2-2) provide pertinent data necessary for the selection of proper size electrical service and over-current protection devices.

Table 8-3 provides data on the minimum copper wire size as a function of supply wire length and circuit ampacity.

Copper Wire Size - AWG (1% Voltage Drop)				
Supply Circuit Ampacity	Supply Wire Length - Ft			
	50	100	150	200
15	14	10	8	6
20	12	8	6	4
25	10	8	6	4
30	10	6	4	4
35	8	6	4	3
40	8	6	4	2
45	6	4	3	2
50	6	4	3	1

Table8-3: Minimum Wire Size Based on N.E.C. for 60 C Type Copper Conductors Below 100 Ampacity.

The owner should be made familiar with the location of the over-current protection, the proper size for this application and the proper procedure for disconnecting power service to the unit.

The condensing unit control wiring requires a 24 Volt minimum, 25 VA service from the indoor transformer as shown on the wiring diagram.

**8.9 INDOOR UNIT INSTALLATION
UNIT DIMENSIONS**

a. For HB*M20 air handler**

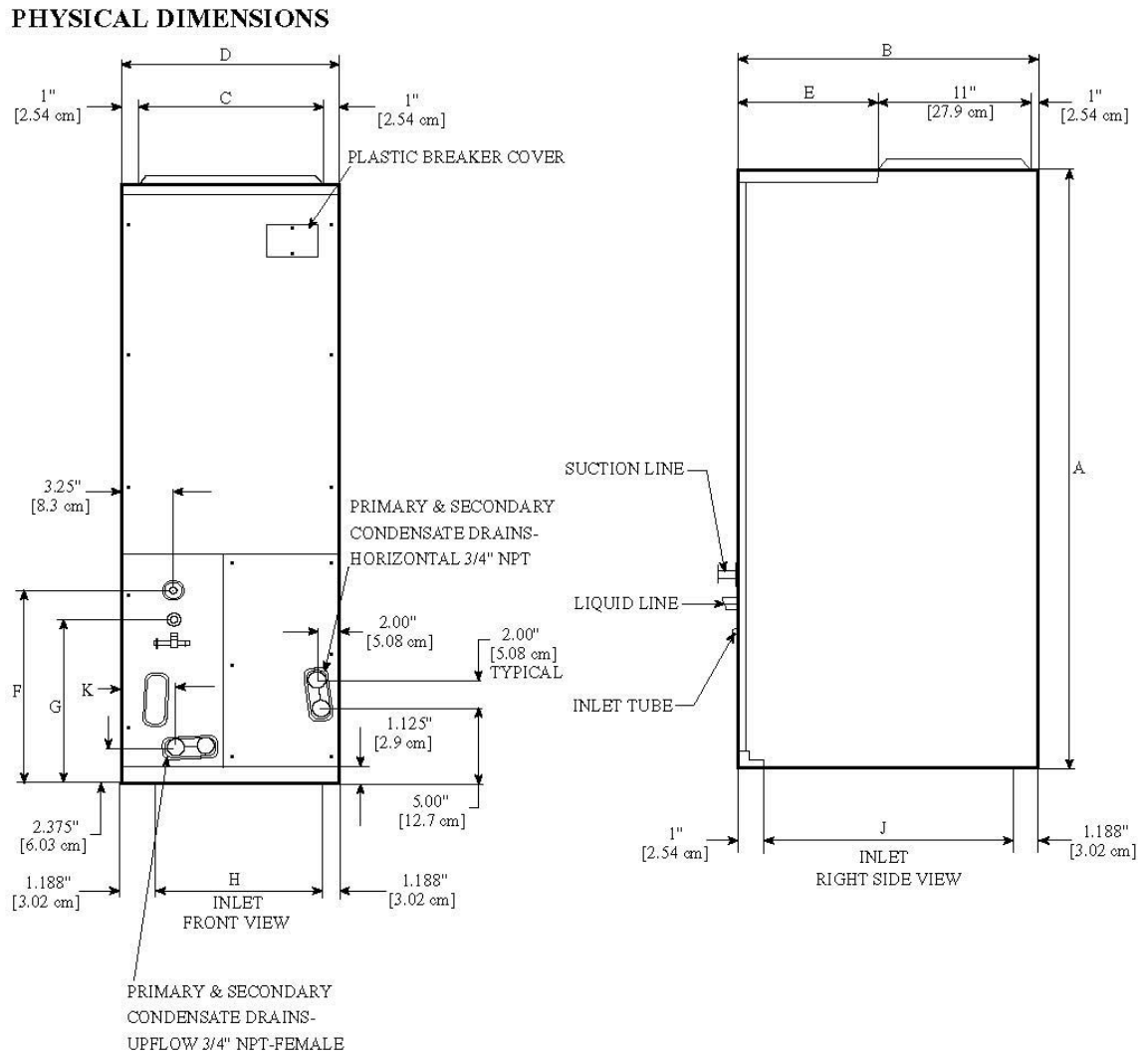

A	B	C	D	E	F	G	H	J	K
46.75	22	17.5	19.5	10	14.5	11.937	17.125	19.812	3.375
[118.7cm]	[55.9cm]	[44.5cm]	[50.0cm]	[25.4cm]	[36.8cm]	[30.3cm]	[43.5cm]	[50.3cm]	[8.57cm]

Fig. 8--3

b. For HB*M25 air handler**

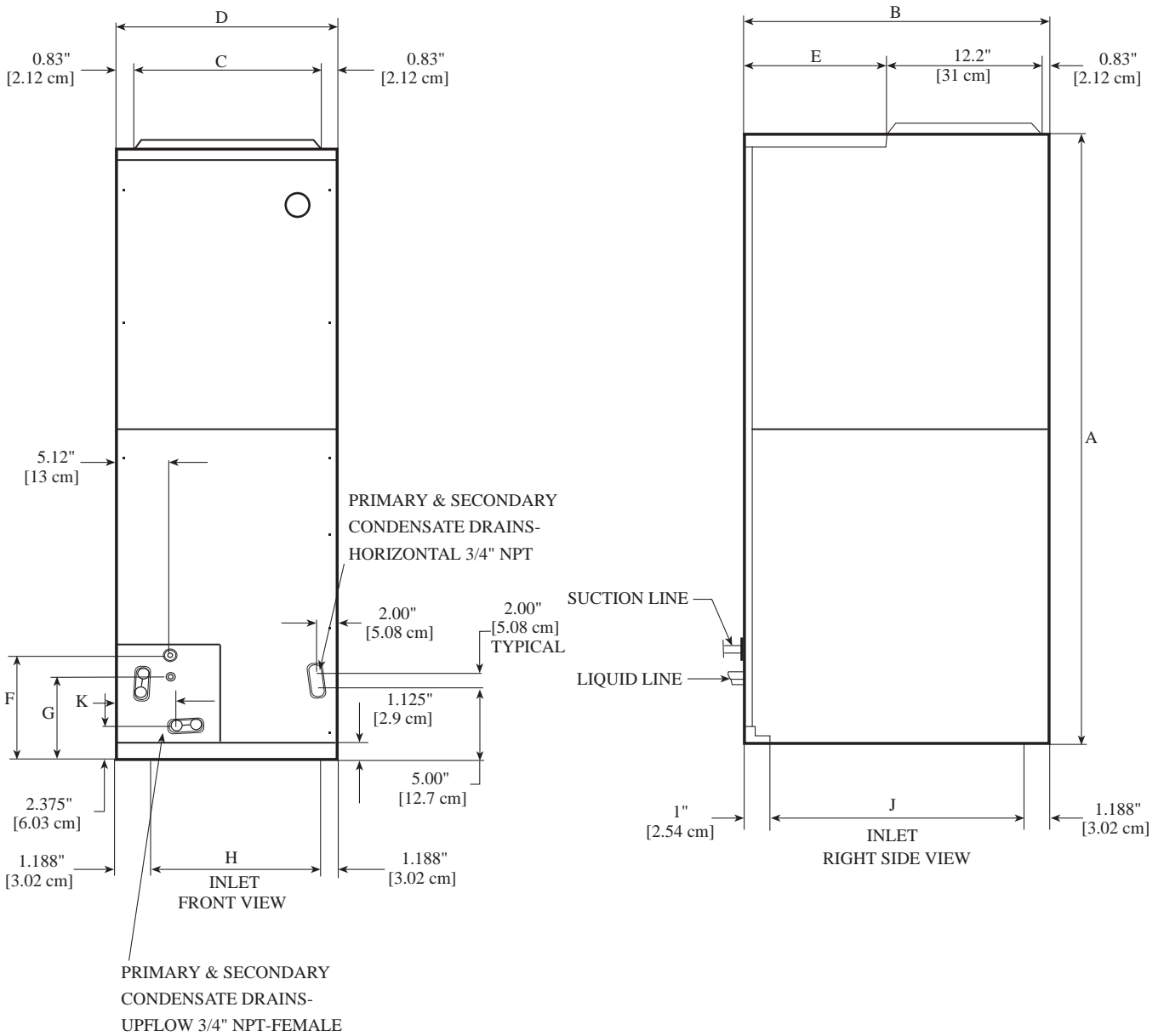

For: HB3600VC1M25

A	B	C	D	E	F	G	H	J	K
53.35	22.9	23.54	25.18	9.06	83.46	5.79	22.64	19.86	3.56
[135.5cm]	[56.1cm]	[59.8cm]	[64.0cm]	[23cm]	[212cm]	[14.7cm]	[57.5cm]	[50.4cm]	[9.05cm]

For: HB42~6000VA1M25 HB6000VC1M25

A	B	C	D	E	F	G	H	J	K
59.45	22.9	23.54	25.18	9.06	83.46	5.79	22.64	19.86	3.56
[151cm]	[56.1cm]	[59.8cm]	[64.0cm]	[23cm]	[212cm]	[14.7cm]	[57.5cm]	[50.4cm]	[9.05cm]

Before installing this appliance insure that it is properly sized and adequate power is available.

This appliance can be installed in the vertical or right horizontal position without modification. The horizontal left and downflow positions require product modification.

This product is designed for zero inch (0") clearance; however, adequate access for service or replacement must be considered without removing permanent structure. This unit can be installed on a platform when deemed necessary.

In an attic installation a secondary drain pan must be provided by the installer and placed under the entire unit with a separate drain line properly sloped and terminated in an area visible to the owner. This secondary drain pan is required in the event that there is a leak or main drain blockage. Closed cell insulation should be applied to the drain lines in unconditioned spaces where sweating may occur.

Appliances installed in garages, warehouses or other areas where they may be subjected to mechanical damage must be suitably guarded against such damage by installing behind protective barriers, being elevated or located out of the normal path of vehicles. When installed on a base, the base must also be protected by similar means.

Heating and cooling equipment located in garages, which may generate a glow, spark or flame capable of igniting flammable vapors, must be installed with the ignition source at least 18" above the floor level.

When more than one appliance is installed in a building, permanently identify the unit as to the area or space serviced by that appliance.

AIRFLOW ORIENTATION

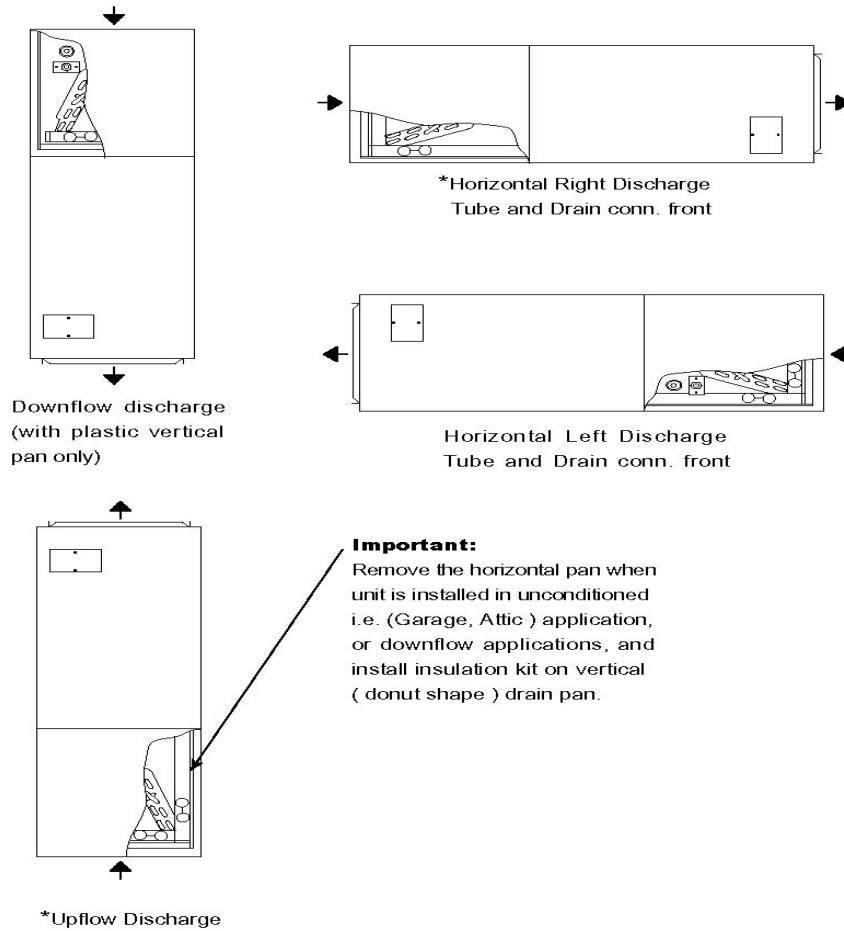

*Air Handler is factory ready for Upflow & Horizontal Right Discharge Application as shown.

Fig.8-4

HORIZONTAL LEFT-HAND INSTRUCTIONS

Important: Read instructions below carefully.

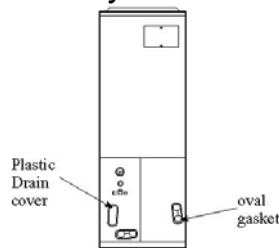

Fig.8-5

- 1) With Air handler in the vertical position, remove all three access panels.
- 2) Remove J-shape metal bracket. Slide out from the Air handler cavity the "A" coil pan assembly with horizontal drain pan on the right side. Remove oval gasket from horizontal pan drain and also remove the plastic drain cover from the lower left access panel. Fig. 8-5
- 3) Relocate horizontal pan on the left-hand side of the "A" coil assembly.
- 4) Knockouts are located within the drain assemblies. Carefully remove only the correct knockouts using a hammer and screw driver for each application, making sure the primary and secondary drains are open and clear of burrs and debris. Remove secondary drain

knockout only if this drain is required in this particular installation.

WARNING: *If incorrect knockouts are removed, flooding will occur.*

5) Reinstall in the Air handler , the "A" coil pan assembly with the horizontal drain pan on the left-hand side.

Note: Push the assembly completely to the rear of the cavity and assure it slips into channel bracket at the rear of the cavity.

6) Replace the J-shape metal bracket or brackets on the vertical drain pan and place the plastic oval gasket on horizontal drain pan. Reinstall access panels and flowrator making sure not to over torque screws. Snap in the drain cover on the right lower service panel.

7) The Air handler can now be placed in its left horizontal position as shown in Fig.2. The Air handler must be leveled and then pitched 1/4" toward drain side. **Important:** Drain pan must be tested for proper drainage by pouring water into the pan. Traps must be installed on the primary drain and on the secondary drain if used.

8) In all cooling applications, a secondary drain pan must be provided by the installer and placed under the entire unit with a separate drain line properly sloped and terminated in an area visible to the user.

9) Before setting up flowrator assembly for field brazing see page 12 or read the **Warning label** on the lower access panel.

10) Failure to follow this installation requirements will cancel product warranty.

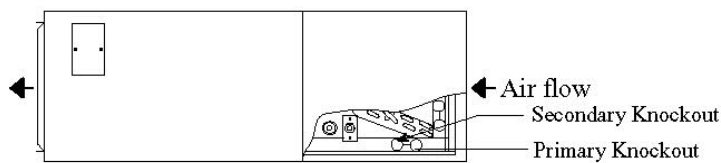

Fig.8-6

DOWNFLOW INSTRUCTIONS

Important: Read instructions below carefully

1. Before putting the Air Handler in the downflow position, remove the three access panels and remove the metal coil retaining bracket and filter close off. Then remove the horizontal and vertical drain pans. The horizontal pan is not required for downflow application

2. After removing the coil, turn the Air Handler to the downflow position and relocate the (8) brackets which include (1) tie bracket (1) rear channel bracket, (2) zee coil supports, (2) stiffener brackets, and (2) 3" 2 flat insulation retaining brackets. In effect, brackets, coil, and 2 lower access panels will be assembled 180 degrees from their former position and shifted down with return in up position as shown in fig.1 and fig.2.

3. Assemble drain pan insulation kit to the bottom of the drain pan to prevent drain pan from sweating during operation.

4. Place 3" flat insulation retainer on the bottom of each coil slab against the aluminum fins as shown in Fig.3. This will reduce the potential for water blow-off into the air stream.

5. Slide the coil assembly into Air Handler and reattach the metal coil retainer bracket to tie bracket. See Fig.2. Then reattach the upper access panel followed by the two lower access panels to match the tubing and drains.

6. A 4" to 3" removable panel is recommended at the point where the duct meets with the return part of the Air Handler unit to allow easier removal of coils that are too tall.

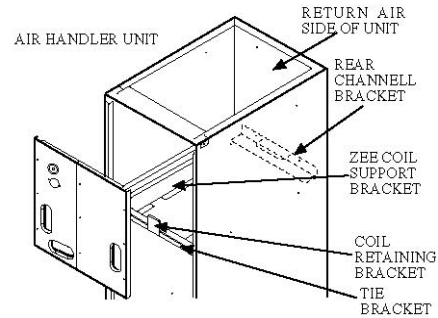

NOTE: THE FILTER PROVISION IS NOT APPLICABLE IN THIS DOWNFLOW APPLICATION

Fig.1

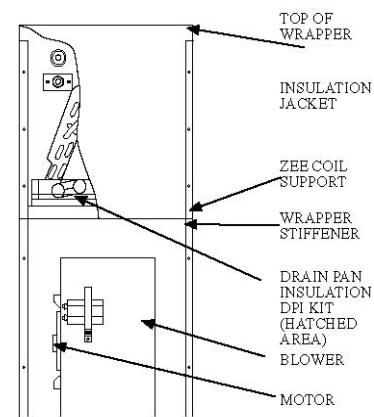

Fig.2

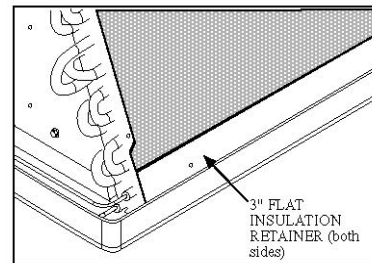

Fig.8-7

7. The "HB" coils are shipped with a check flowrator for use with either cooling or heat pump outdoor section which is accessible from the outside of the unit.

WARNING: The "A" coil contains 150 p.s.i.g. of air pressure

Before setting up flowrator assembly for field brazing see page 12 or read the Warning label on the lower access panel.

REFRIGERANT TUBING

Refrigerant tubing should be installed as to avoid undue stress. They must be supported or routed to avoid strain or vibration. To avoid damage that can be caused by condensate, insulate the suction tube with a closed cell insulation with the seams sealed. The insulation should terminate at the tubing entrance to the air handler. Do not reduce the recommended tubing size.

CONDENSATE REMOVAL

THIS APPLIANCE EMPLOYS A DRAW-THROUGH COIL, THEREFORE A TRAP MUST BE INSTALLED IN THE DRAIN LINE(S) TO ALLOW FOR PROPER CONDENSATE DISPOSAL.

The condensate trap must not be the "running" type, or "R" type. A "P" trap is required. The total workable height of this trap, in inches, must exceed the total negative pressure, in inches of water, as measured in the return duct.

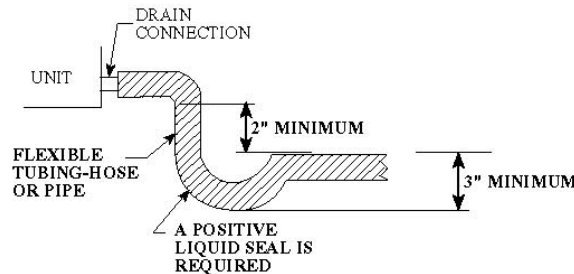

Fig.8-8

The condensate drain line must be at least 3/4 NPT, for each unit. Precautions must be used not to over tighten the adapter at the drain pan connection, this precaution will prevent damage to the plastic drain pan. A joint compound should be used to prevent leakage and act as a lubricant.

When using copper tubing as a condensate line adequate caution must be taken to prevent damage to the plastic drain pan during the soldering process. All condensate drain lines and drain traps should be adequately insulated.

The unit and the auxiliary drain pan must be adequately elevated to insure proper drainage.

Use of a condensate removal pump is permitted when necessary. This condensate pump should have provisions for shutting off the control voltage should a blocked drain occur. A trap must be installed between the unit and the condensate pump. **Important: The evaporator coil is coated with oils that will dissolve Styrofoam and certain types of plastics. Therefore a removal pump or float switch must not contain any of these materials.**

ELECTRICAL CONNECTIONS

The required electrical power supply information is located on the series and rating plate on the exterior of the unit. Wiring selection must be in accordance with local codes, or in absence of local code, the National Electrical Code. A disconnect means should be installed within sight of the unit, when required by code.

Copper wire is recommended for all electrical connections.

When an optional heat kit is installed refer to the electrical requirements in that kit.

The wiring diagram included in the heat kit must be placed over the wiring diagram on the air handler.

All pertinent information, such as the rating plate, included in the optional heat kit must be applied to the Air Handler as indicated.

The use of copper connections are recommended inside the control box (see UL 1995, section 37.9).

TABLE 8-4

Model (indoor units)	Min. ampacity 208/230V	Max. Over- current(A) 208/230V	Fan motor capacitor(UF)	Blower motor FLA	Blower motor HP
HB2400VA1M20	/	15/15	8	0.9	1/8
HB2400VC1M20	/	15/15	8	0.9	1/8
HB3000VA1M20	/	15/15	7.5	2.3	1/3
HB3600VA1M20	/	15/15	7.5	2.3	1/3
HB3600VC1M25	/	15/15	7.5	2.3	1/3
HB4200VA1M25	/	15/15	7.5	2.2	1/2
HB4800VA1M25	/	15/15	7.5	2.2	1/2
HB6000VA1M25	/	15/15	12	4	3/4
HB6000VC1M25	/	15/15	12	4	3/4

A MEANS OF STRAIN RELIEF MUST BE INSTALLED TO THIS APPLIANCE AT THE ELECTRICAL SERVICE ENTRANCE.

When an optional electric heat kit is installed refer to the electrical requirements for that kit. The ampacity and over-current protection shown above is only for "HB" air handlers installed without a heat kit.

8.10. SYSTEM STARTUP

1. Turn thermostat to "OFF", turn on power supply at disconnect switch.
 2. Turn temperature setting as high as it will go.
 3. Turn fan switch to "ON". Indoor blower should run. Be sure it is running in the right direction.
 4. Turn fan switch to "AUTO". Turn system switch to "COOL" and turn temperature setting below room temperature. Unit should run in cooling mode.
 5. Check to see if compressor and outdoor fan are running correctly?
 6. Check the refrigerant charge (see Instructions under "Charging the System").
 7. Replace service port caps. Service port cores are for system access only and will leak if not tightly capped.
 8. Check unit for tubing and sheet metal rattles.
 9. Instruct the owner on operation and maintenance.
- Leave this "Installation and Operating Manual" and the "Use and Care Manual" with owner.

8.11. OPERATION

SEQUENCE OF OPERATION

In order to service and troubleshoot a air conditioning system a service technician must understand the unit's sequence of operation. this is the order of events the system undergoes to cycle itself on and off. Knowing how the units operate properly aids in determining where to start troubleshooting when the unit doesn't operate properly .Where the system varies from its normal sequence is a major clue to any problems.

COOLING CYCLE

Mechanical . the operation sequence as follows:

1. The compressor pumps out high pressure ,superheated refrigerant vapor.
2. The vapor leaves the compressor and passes through the reversing valve.
3. It flows through the outdoor vapor line to the finned outdoor coil. Air from the outdoor fan removes heat from the refrigerant vapor .When enough heat is removed ,the vapor condenses into a high pressure liquid .The liquid temperature is slightly warmer than ambient air temperature.

4. This warm ,high pressure liquid leaves the outdoor coil ,and flows through the small copper refrigerant liquid line.
5. At the end of the liquid line the refrigerant passes through the a flowcheck device ,reducing a pressure and temperature .
6. As the cool liquid ,under reduced pressure ,enters the indoor coil surface it expands and absorbs heat from the indoor air passing over the finned surface ..Heat from the indoor air ,causes the low pressure liquid to evaporate and cools the indoor air. The refrigerant is now a cool vapor.
7. The cool refrigerant vapor travels through the larger ,insulated vapor line to the accumulator .
8. The accumulator separator separates any liquid refrigerant and holds it. Only vapor refrigerant and refrigerant oil leave the accumulator .The oil is drawn out through a special port inside the accumulator.
9. Refrigerant vapor flows through the suction line to the intake of the compressor .The cycle then repeats.

Electrical . The operation cycle as follows:

1. The thermostat calls for cooling
2. This sends a 24 voltage signal through the “Y” terminal to the compressor start kit ,after 3 minutes the compressor contactor in the outdoor unit are closed .The compressor and outdoor fan start.
3. At the same time ,a 24 Voltage signal flows through the “G” Terminal to the indoor blower relay.. The indoor blower starts.
4. the cooling system is now in operation.
5. The thermostat satisfies and ends the call for cooling.
6. This ends the 24 Voltage signal to the compressor start kit and the outdoor unit stops.
7. This ends the 24 voltage signal to the indoor blower relay and this indoor blower strips
8. The system is now off.

9.MAINTENANCE INSTRUCTIONS

FILTERS

WARNING: DISCONNECT MAIN ELECTRICAL POWER TO THE UNIT BEFORE ATTEMPTING ANY MAINTENANCE.

1. Keep the air filters clean .A new home may require more frequent filter attention until dust from the construction is removed.
2. Replace glass fiber filters when dirty.
3. Clean semi-permanent plastic impregnated fiber filters :
 - A. Vacuum clean; or B: Wash with detergent and water ,air dry thoroughly and re-install.

Caution: Do not operate any system without filters

Note: if an electronic air cleaner is installed, remove any mechanical filter from the air handler. Follow the maintenance instructions furnished with the electronic cleaner.

LUBRICATION

In today's products, indoor blower motor bearings and outdoor unit fan motor bearing are pre-lubricated by the motor manufacturer.

Motors with oil ports: Add 10 to 20 drops of Electric motor oil or an SE-grade ,non-detergent ,SAE 10-OR 20-grade motor oil to each bearing.

- A. every two years for continuous duty,
- B. at least every three years for somewhat continuous duty .
- C. at least every five years for light duty.

To access oiling ports or to re-lubricate the sealed bearing of the indoor blower motor, remove the blower assembly.

For access to the outdoor fan motor, remove the unit top and turn the motor onto its with the oil ports up.

OUTDOOR COIL CLEANING

Keep the outdoor coil clean for complete air flow and proper operation .Do not allow leaves ,grass clippings or other material to obstruct the coil. Do not allow anything to block the coil. Keep fences, shrubs, or other obstructions at least 24” away from the coil air inlets.

If the coil becomes obstructed, clean it with water from a garden hose.

- A. First **TURN OFF ELECTRICAL POWER** to the outdoor unit
- B. Remove the top with the outdoor fan attached.
- C. Flush water through the coil from the inside out.

NOTE: Do not to get water on any controls or other electrical devices. If anything electrical gets wet, dry it thoroughly before energizing.

There are commercial coil cleaning solvents. Follow the solvent manufacturer's instructions when using. Normally the solvent is sprayed onto the coil. Allow several minutes for the solvent to dissolve any organic matter. Wash away the solvent and any dissolved matter with water from a garden hose.

NEVER USE A WEATHER COVER OVER THE OUTDOOR UNIT. The unit is designed to operate outdoors. A cover traps moisture in the unit causing rust and corrosion. There is the added danger of starting the system with the cover on. This prevent air flow through the outdoor coil causing dangerous system pressure. Compressor damage result.

INDOOR COIL MAINTENANCE

Inspect the indoor coil at least once a year for cleanliness and clean as necessary.

1. The coil can be cleaned when dry. If it is coated with lint or dirt, blow compressed air or nitrogen (NEVER USE REFRIGERANT) through the supply air side of the coil fins. Place a sheet of metal or cardboard under the return air side of the coil to catch any debris before it gets into the air handler.
2. If the coil is coated with oil or grease, clean with a mild detergent and water solution. Rinse thoroughly with clear water. Be careful not to get water into the air handler.
3. After cleaning the coil, inspect the drain pan and condensate line. Remove any debris from the pan and flush with clear water.
4. Use high pressure water to clear any clog in the condensate line.

WARNING: DO NOT USE CAUSTIC HOUSEHOLD DRAIN CLEANERS IN THE CONDENSATE PAN OR NEAR THE INDOOR COIL. THESE DRAIN CLEANERS QUICKLY DAMAGE THE INDOOR COIL.

10. SERVICE AND TROUBLESHOOTING

WARNING: THE ABILITY TO PROPERLY PERFORM SERVICE ON THIS EQUIPMENT REQUIRES CERTAIN EXPERTISE, MECHANICAL SKILLS, TOOLS AND TEST EQUIPMENT. IF YOU DO NOT POSSESS THESE, DO NOT ATTEMPT TO PERFORM ANY MAINTENANCE ON THIS EQUIPMENT OTHER THAN THOSE PROCEDURES RECOMMENDED IN THE USER'S MANUAL.

A FAILURE TO FOLLOW THIS WARNING COULD RESULT IN POSSIBLE DAMAGE TO THE EQUIPMENT, SERIOUS TO THE EQUIPMENT, SERIOUS PERSONAL INJURY, OR DEATH.

The HVAC industry, like the auto industry, is faced with increasing government imposed efficiency regulations. New and more sophisticated mechanical means for achieving higher efficiencies have been engineered. The use of test equipment is now more critical than ever.

In the servicing and troubleshooting section is information on compressors and other components and their test procedures. There are troubleshooting charts, charging charts, wiring diagrams and service analyzer charts. Included is list of suggested test equipment.

Use this information to service and understand the installation, operation and troubleshooting of the current families of air conditioning. The procedures in this section are of necessity, generic in content. Each product family incorporates some of these components. Be aware of this is a guide compiled from numerous sources. It can not take into consideration all conditions found in all installations.

Note: Upon arrival at the job site, inspect the installation. Make sure the installation was done according to the manufacturer's **Installation and Operation instruction Manual. Have a copy of the manual in case it was not left on the job site.**

REFRIGERANT RECOVERY

Refrigerant system using chlorofluorocarbon (CFC) and Hydrochlorofluorocarbon (HCFC) refrigerant have been subjected to increase regulation, due to **the clean air Act of 1990.** This act prohibits the unrestricted release of refrigerant into the air. Proper charging of refrigerant system may require removing some refrigerant when the system is overcharged. How does one comply with the act and also provide the service that the customer needs? By recovering the excess refrigerant.

Recovery means to pump the special holding container. **Recycling** means to run the refrigerant through a filtering system to remove most particles and moisture. **Reclaiming** means to chemically reprocess the refrigerant to return it to its original purity.

Recovering and recycling refrigerant is possible with the aid of mechanical devices made for the purpose. The recovery system is a compressor-driven pump assembly, which removes refrigerant from

a system and safely stores it in a department of Transportation (DOT) approved container until it is **re-used or returned for reclaim.**

The authors of the EPA regulations enforcing the Clean Air Act realized that an accidental release of the refrigerant may happen in the course of normal service. Any such incidents that happen while making “good faith” attempts to recover refrigerant would be considered .Always use procedures so as not to release any refrigerant .Purging the hoses to clear them of air is an example. The latest refrigerant hoses have a valve within twelve inches of their ends .The entire hose does not have to be purged .

When performing service on a refrigerant system, charging should be done using the best service practices ,ensuing that the least amount of refrigerant needed is used.

After fabrication and installation of the lines, do not flush a line set with refrigerant., venting refrigerant to the atmosphere subjects both the installer or the technician and their employer to federal fines. Lines must be evacuated before charging with refrigerant.

Each installer and technician must be informed on the provisions of the clean Air Act and understand the impact on the installation and service of the refrigerant systems. Each technician must be certificated under an approved program .Failure to properly handle refrigerant may cost technician’s job and also a stiff fine. Up to \$25,000 may be charged for a pattern of disregards, concerning this very important federal law.

WARNING : FOR YOUR OWN PROTECTION ,ALWAYS HAVE A RECOVERY/RECYCLING DEVICE PRESENT WHEN DOING REFRIGERANT SERVICE.

TEST EQUIPMENT

The following test equipment is recommended to properly service air conditioning equipment:

- 1.A good quality volt/ohm meter;
- 2.A two-temperature electronic thermostat;
- 3.A Magnetic Gauge (capable of reading to 3” W.C.)
- 4.A Gauge manifold set
- 5.A clamp-on ammeter.
- 6.An electronic leak detector or bottle of soap suds.
- 7.A micron meter (not shown)
- 8.A vacuum pump capable of pulling to 2000 microns;
- 9.Refrigerant recovery /recycling equipment

NOTE: Carry and store any test equipment in a manner to prevent damage.



vacuum pump
Fig.10-1

Before beginning any troubleshooting procedure ,complete the following installation checklist. An equipment problem is sometimes caused by an improper installation. By completing this checklist the problem may be found and corrected .Make copies of the checklist and complete one for every air conditioning system call for your records.

10.2 INSTALLATION AND SERVICE CHECKLIST
(Refer to the unit installation instructions for the specifics)

ELECTRICAL

-Correct the thermostat and subbase
-Correct thermostat mode and setting
-Correct line supply voltage for indoor and outdoor units
-Proper equipment ground to the electrical panel

-Correct control voltage
-Proper disconnect switches and breakers for indoor and outdoor units
-Correct wire sides for both indoor and outdoor units.

OUTDOOR UNIT INSTALLATION

-Unit level with proper clearances for air flow and service
-Proper elevation of outdoor unit
-Solid pad
-Coil free from dirt and debris
-Unit charged according to manufacturer's instructions
- Any evidence of refrigerant leaks

REFRIGERANT LINES

-Proper length according to manufacturer's instructions
-Proper size according to manufacturer's instructions
-Large vapor line insulated
-No inadvertent oil traps
-No kinks or restrictions
- Any evidence of refrigerant leaks

INDOOR UNIT INSTALLATION

-Adequate clearances for air flow and service
-Adequate supply and return air ducting
-Air ducts sealed to prevent leakage
-Correct filter(s)
-External static pressure_____ inches W.C.
- Proper air flow (about 400 CFM per ton)
-Correct indoor coil and accessories
- Any evidence of refrigerant leaks
- Condensate line piped with trap and vent
-Horizontal drain pan installed in horizontal applications
- Auxiliary drain pan installed in horizontal applications
- Auxiliary condensate line installed in horizontal application

CAPACITOR ELECTRICAL CHECK

WARNING :ANY CAPACITOR SHOWING SIGNS OF LEAKS OR BUDGING MUST BE REPLACED IMMEDIATELY. DO NOT OPERATE THE COMPRESSOR WITH A CAPACITOR SHOWING THESE SIGNS.

Single phase compressors require a run capacitor connected to the run and start windings .This puts the two windings out of phase from one another and allows the compressor motor to start. Use a capacitor analyzer to determine if the capacitor dielectric is becoming weak, or if the MFD value has changed .If a capacitor analyzer is not available ,use a quality ohmmeter to check the resistance between the capacitor plates

1. Set the ohmmeter to the highest scale available
2. Discharge the capacitor by shorting the terminals with the blade of a screwdriver having an insulated handle.
3. Place the Ohmmeter probes on the capacitor terminals and read:
 - A. The meter pointer moves towards zero, then gradually moves to higher ohm values ,the capacitor is GOOD
 - B. The meter pointer does not move. An Open capacitor- REPLACE.
 - C. The meter pointer goes toward ZERO ohms and stays A shorted capacitor –replace.
4. Replace any failed capacitor with a capacitor having the same MFD and voltage rating.

COMPRESSOR START KITS



Run capacitor
Fig.10-2

Some compressor require the assistance of an additional potential relay to start. The potential relay connect to the contactor. The potential use two terminals:5 and 2 ;The relay coil that opens them is between terminal 2 and 5

START KIT ELECTRICAL CHECKS

WARNING:DISCONNECT ALL POWER TO THE OUTDOOR UNIT BEFORE BEGINNING THIS TEST .

MOTORS

ELECTRICAL

The motors in both the outdoor unit and indoor unit are similar .Outdoor motors have one speed while indoor unit usually are multi-speed. All fan motors require a capacitor for the best torque and efficiency. If the motor is replaced, replace the capacitor.

The fan motor has both “Run” and “Start “windings .Extended run windings furnish a choice of speeds with indoor products. Use an Ohmmeter to troubleshooting motors.



Indicator
Fig.10-3

ELECTRICAL CHECKS

1. **Be sure power is off to the motor.**
2. Disconnect the motor wires.
3. Place one ohmmeter lead on **common** and the other on **start** .The meter should show continuity.
4. Place one ohmmeter lead on **common** and the other on **run**. The meter should show continuity with less resistance.
5. Leave one meter lead on **common** and touch each remaining lead. Each should indicate continuity.
6. If a winding does not show continuity, the motor has failed and must be replaced.
7. If the motor needs replacing, replace the capacitor as well.

MECHANICAL

Fan motors can suffer a bearing loss due to a lack of lubrication .This may be caused by excessive water spilling from a roof above the unit. Lubrication can be washed out of permanently lubrication causes dirt to stick to oiling ports and can contaminate the bearings. If a motor fails, replace it with another having the same rotation and

electrical characteristics.

CONDENSER FAN BLADE LOCATION

Dimension “A” will be from 2” to 4” depending on the unit model number. Be sure to check this dimension BEFORE removing the fan blade.

Note: When parts combination results in motor /blade interference ,the fan blade should be located to provide 1/8” motor /blade clearance.

RELAYS

ELECTRICAL OPERATION

Relay coils are wires wound around an steel core. When energized a coil becomes a magnet opening or closing contactors, that makes or breaks electrical circuits. Electrical continuity indicates a good coil. Relay coils use specific voltage. Using the wrong voltage either destroy the relay or it just doesn’t operate .Avoid this by using the proper replacement part for a failed component.



Fig 10-4

Relay contacts are switched and can become pitted or corroded, creating resistance .Corrosion can generate enough heat to weld the contacts together. Physical examination of the contacts shows this problem. With sealed relays ,use an ohmmeter to show open or closed contacts.



Fig.10-5

ELECTRICAL CHECKS

1. **BE SURE ALL THE ELECTRICAL POWER IS OFF TO THE COMPONENT BEING CHECKED.**
2. Remove at least one wire from the component being checked.
3. Measure the resistance of the holding coil with an ohmmeter
 - A. A special resistance indicates a good holding coil.
 - B. Infinite (∞) resistance indicates a relay with an open holding coil. REPLACE this relay with an identical part.
4. Measure the resistance across the normally closed (NC) relay contacts.
 - A. The resistance should be zero (0) ohms.
 - B. If the resistance is more than 0.2 ohms the contacts are pitted .REPLACE this relay with an identical part.
5. Measure the resistance across the normally open (NO) relay contacts.
 - A. The resistance should be Infinite (∞)
 - B. If the resistance isn’t Infinite (∞),REPLACE this relay with an identical part.

MECHANICAL CHECKS

In relays ,mechanical faults are few. with the exception of physical damage .

AIR FLOW

Indoor coil air flow in any air conditioning system is critical. Too much air and the customer suffers lack of the dehumidification in cooling. Too little air in cooling and coil may freeze.

Check air flow is the most important checks. Instructions can measure pressure drop across the coil .If pressure

drop tables are available, they indicate the cubic feet of air per minute (CFM) moving through the coil. An inclined manometer is an example of this type of instrument.

A velometer measures the velocity of the air in feet per minute (FPM). If the area of duct is known, the velometer reading times the area of duct (in square feet) calculates the air flow.

There are also simple mathematical formulas that are needed. All of them require measurement be taken. These measurements require a voltmeter, ammeter and a good temperature tester.

Caution: these following procedures can only be done with electric resistance heaters.



$$\text{CFM (Electrical Heater)} = \frac{\text{VOLTS} \times \text{AMPS} \times 3.414}{1.08 \times \text{TEMP RISE}}$$

COMPRESSOR AND SYSTEM FAULT DIAGNOSIS

Many returned compressors have nothing wrong with them. To ensure that does not happen, the technician must determine if the compressor has failed or if another control has either failed or stopped the compressor after detecting a problem. The following procedures should help determine if the compressor has failed.

Prior to replacing a suspected failed compressor, a thorough check must be made of all existing electrical components. If not done, a replacement compressor might also fail or not operate at all.

WARNING: THE FOLLOWING PROCEDURES SHOULD ONLY BE ATTEMPTED BY A QUALIFIED LICENSED SERVICE TECHNICIAN EQUIPPED WITH PROPER TOOLS AND INSTRUMENT SUCH AS A REFRIGERANT RECOVERY, VACUUM PUMP, VOLTMETER, AMMETER, OHMMETER, THERMOMETERS, PRESSURE GAUGES, MICRON METER, ETC.

COMPRESSOR ELECTRICAL CHECKS

Single-phase compressors use permanent split capacitor motors. There are two windings that connect at a common point at the "common" wiring terminal. The two windings are called "start" and "run". The start winding has the higher resistance and is connected in series with the capacitor. The run winding has the lower resistance and connects directly to the power supply from the compressor contactor.

The design uses a protective device called an "internal overload" if it detects either dangerously high amperages or temperatures in the compressor motor, it opens an internal circuit to stop the motor.

ELECTRICAL CHECK COMPRESSORS

1. Consult the unit wiring diagram. Determine that all electrical wiring for the units is correct and that all wiring connections are right.
2. Measure the available line voltage.
 - A. On the single phase 208/230 Volt units, this should be from 197 to 253 Volts.
3. Check for proper control voltage at the unit contractor coil. If this voltage is inadequate or is not present, refer to the wiring diagram or the compressor troubleshooting flow chart at the end of this section for possible causes.
4. Remove all power from the unit and visually inspect the compressor contactor for pitted or burned points.
 - A. This could indicate high or low voltage problems or improper start components.
 - B. Check the contactor coil with an ohmmeter for a short or open circuit.
 - C. Replace the contactor if any fault is noted.
5. **WITH THE ELECTRICAL POWER OFF**, remove all power wires from the compressor terminals, **MARK THE ORIGINAL LOCATION OF EACH WIRE**.
 - A. Use an ohmmeter set for the highest scale to check for grounding between compressor motor terminals and a good clean ground such as the compressor shell or copper line.
 - B. The resistance from any terminal to ground should exceed 1,000,000 ohms.
6. Use an ohmmeter set for the lowest scale and check the continuity of the motor windings. These ohm values are less than ten ohms and in some cases less than one ohm.
 - A. Lowest from RUN terminal to common terminal.

.lowest ohm value of the three measurements.
 .Approximately 1.0 ohms

B. Measure from Start TERMINAL TO COMMON TERMINAL.

.Middle ohm value of the three measurements.

.Approximately 2.0 to 3.0 ohms

C. Measure from Start TERMINAL TO Run terminal.

.Highest ohm value of the three measurements.

.Approximately the sum of the first two measurements.

EXAMPLE:

Run to Common -1.0 Ohms

Start to Common -4.0 Ohms

Start to Run -3.0 Ohms

Good compressor motor :

Run to Common $-\infty$ Ohms

Start to Common $-\infty$ Ohms

Start to Run -3.0 Ohms

OPEN COMPRESSOR INTERNAL OVERLOAD-ALLOW THE COMPRESSOR MOTOR TO COOL AND THE INTERNAL OVERLOAD TO RESET.

Run to Common -1.0 ohms

Start to Common $-\infty$ Ohms

Start to Run $-\infty$ Ohms

OPEN COMPRESSOR START WINDING---REPLACE THE COMPRESSOR .

7.The resistance from one winding terminal to any other terminal should be the same with three phase compressors. **NOTE:** on larger 208/230 volt compressors the ohm values could be as low as 0.10 ohms, THIS IS NOT A SHORTED WINDING .A winding is open if resistance measured is infinite(∞).

COMPRESSOR MECHANICAL CHECKS

Compressors fail mechanically due to bearing failure ,valve failure ,or damage to the internal suspension system. Bearing and valve failure is almost always caused by liquid refrigerant .**COMPRESSORS CAN ONLY PUMP REFRIGERANT VAPOR** .Liquid refrigerant damages the valves by deforming or breaking (slugging) them. It damages the bearing by diluting the lubricating oil.

SYSTEM PUMP DOWN

This procedure tests the compressor valves .It can indicate internal refrigerant leaks such as through the liquid line service valve. The procedure uses the compressor to trap all the refrigerant inside the condensing coil (outdoor cooling) .The technician's gauges indicate if the condensing coil holds the refrigerant as intended or if it leaks out.

Procedure

1. Connect the compound refrigerant gauge to a service port that is always suction pressure such as on the compressor shell, or in the line between accumulator and compressor. Connect the high pressure gauge to a service port that is always high pressure .
2. With the unit operating ,from seat (close) the liquid line service valve. Observe the gauges .The suction pressure should fall. The high pressure should also fall slightly. If the discharge pressure rises above 400 psi, **Shut off about outdoor unit.**
3. **SHUT OFF THE COMPRESSOR WHEN THE SUCTION PRESSURE DROPS TO 3-5 PSI. POSITIVE PRESSURE .DO NOT OPERATE THE COMPRESSOR WITH A NEGATIVE SUCTION PRESSURE.**
4. Observe the suction pressure on the compound gauge.

- A. suction pressure holds. **normal condition.**
- B. Suction pressure rises to a point and stops.
 - . Some refrigerant finally evaporated in the coil and made its pressure felt on the gauge .**Normal condition .Do not start the compressor** to force this little refrigerant into the condenser.
- C. Suction pressure rises and eventually equalizes with the high pressure .
 - Abnormal condition.**
 - . Refrigerant is leaking from the condenser coil .
 - Causes** :Leaking liquid line valve, leaking discharge check valve (scroll compressors only), leaking compressor valves.
 - ACTION:** Determine the causes and correct it.
- D. Suction pressure Never drops to 3-5 PSI. **Abnormal condition.** Refrigerant is leaking from the condenser coil .
 - Causes** :Leaking liquid line valve, leaking discharge check valve (scroll compressors only), leaking compressor valves.
 - ACTION:** Determine the causes and correct it..

REFRIGERANT NONCONDENSIBLES CHECK

This procedure checks the quality of the refrigerant by comparing the refrigerant pressure to its temperature .The test tells if there are contaminating non-condensable gases in the refrigerant ,usually air and moisture ,or if the proper refrigerant is in the system.

Table

Temperature Pressure Chart

TEMP Deg F	R22	TEMP Deg F	R22	TEMP Deg F	R22	TEMP Deg F	R22
-150	*29.4	-30	4.9	35	61.5	100	196.1
-140	*29.1	-25	7.5	40	68.5	105	210.8
-130	*28.5	-20	10.2	45	76.1	110	226.4
-120	*27.7	-15	13.2	50	84.1	115	242.8
-110	*26.6	-10	16.5	55	92.6	120	260.8
-100	*25.1	-5	20.1	60	101.6	125	278.0
-90	*23.0	0	24.0	65	111.3	130	297.0
-80	*20.2	5	28.3	70	121.4	135	316.7
-70	*16.6	10	32.8	75	132.2	140	337.4
-60	*11.9	15	37.8	80	143.7	145	359.1
-50	*6.1	20	43.1	85	155.7	150	381.7
-40	0.6	25	48.8	90	168.4		
-35	2.6	30	54.9	95	181.8		

Table 10-1

1. Pump the system down as the explained in the previous procedure. open the unit disconnect to SHUT Down the system when the suction pressure drops to 3-5 psi positive pressure .
2. Front SEAT THE LARGE VAPOR LINE VALVE.
3. De-energize the compressor .**REMOVE EACH WIRE FROM THE COMPRESSOR TERMINALS .MARK AND IDENTIFY THE WIRE TERMINALS.**
WARNING :WRAP A LAYER OF INSULATION ELECTRICAL TAPE OVER THE WIRE TERMINALS , NOT THE COMPRESSOR TERMINALS .THIS WIRE END IS HOT WITH VOLTAGE DURING THE REMINDER OF THE TEST .
4. Energize the system and run the condensing fan .Measure the condensing coil entering and leaving air temperature with accurate thermometers.
5. Run the condensing fan until the leaving air temperature equals to the entering air temperature. This is now the refrigerant temperature .
6. Compare the refrigerant pressure shown on the high pressure gauge to its associated pressure on a temperature –pressure conversion chart.
7. The refrigerant pressure should equal the chart pressure for the given temperature.
 - A. The system pressure is above the chart pressure. **Cause** :Non-condensables are present –air

and moisture. **ACTION:** Remove and recover the refrigerant .Evacuate the system Charge with fresh ,clean refrigerant.

- B. The system pressure is below the chart pressure. **Cause :**A mixed refrigerant is present .
ACTION: Remove and recover the refrigerant .Evacuate the system Charge with fresh ,clean refrigerant.

COMPRESSOR REMOVAL PROCEDURES

USE THESE PROCEDURES ONLY IF A PROVEN BURN OUT OR A FAILED COMPRESSOR BY ELECTRICAL CAUSES HAS BEEN DETERMINED.

CAUTION: After a server motor burn out the products of the burn out the products of the burn out may be acidic. The technician should wear rubber gloves and eye protection to prevent injury.

Use the following procedure for compressor removal ONLY after determining that the compressor has failed.

1. **DISCONNECT THE MAIN POWER SOURCE TO THE UNIT AND LOCK THE DISCONNECT SWITCH IN THE OPEN POSITION.**
2. Disconnect the electrical wiring at the compressor identifying each wire and its location.
3. Remove the refrigerant charge from the entire system using proper recovery pressures.
4. Remove the failed compressor.
 - A. Unsolder the suction and discharge lines at the compressor stubs.
 - B. Remove the compressor hold down bolts.
 - C. Place the failed compressor on a smooth surface to remove the mounting grommets and sleeves for use with the new compressor .
 - D. Prevent any contamination from entering the refrigerant lines.
5. Conduct an acid test on the oil from the failed compressor .
 - A. Secure a generous sample of oil from the failed compressor.
 - B. Follow the oil test kit instructions to determine the degree of compressor burn out .
 - As a general rule, oil with a test number less than 0.05 indicates a mild burn out.
 - Oil with a test number greater than 0.05 indicates a serve burn out .
 - Some oil test kits indicate severity by color charge .
 - As a guide ,burn out classifications are as follows:
 oil clear ,no color ,Possibly no burn out –mechanical failure.
 oil clear ,slight color ,Possibly a mild burn out .
 oil very dirty ,strong odor test >0.05 –severe burn out .

Note: Dispose of any contaminated refrigerant oil in accordance with all environmental regulations and procedures.
6. Use the following procedures with units having mild to severe burn outs.
 - A. After compressor removal ,insert a clean ,lint free swab into the system ‘s suction and discharge lines to determine the extent of contamination.
 - B. If contamination is noted for a considerable depth ,replace with new tubing.
 - C. Check that the new compressor has no shipping damage. The line connections must come sealed from the factory .Ensure that it is correct replacement compressor of the same size and electrical characteristics as the original.
 - D. Place the new compressor in the unit and install the mounting bolts.
 - E. Remove the caps from the compressor stubs ,clean the lines and stubs, and braze joints together.

Warnings:

1. **KEEP CONTAMINATIONS OUT OF THE LINES,**
2. **USE MINIMUM 5% SILVER FOR COPPER TO COPPER CONNECTIONS.
USE MINIMUM 35% SILVER FOR COPPER TO STEEL CONNECTIONS.**
3. **PURGE DRY NITROGEN THROUGH THE LINES TO PREVENT OXIDATION.**
- F. Inspect all other components such as check valve and electrical components for copper operation. Replace any if necessary.
- G. After all connections are made ,open all valves pressurize to 150 psi with dry nitrogen and leak test with liquid detergent. If a leak is found ,repair it after removing the nitrogen ,and recheck.
- H. After leak testing ,recover any test refrigerant.
- I. Triple evacuate the system.
 - .Evacuate through both high and low sides of the system.
 - .Evacuate to 1500 microns twice and 500 microns the last time.

- .Break each vacuum with dry nitrogen to 3.0 psi.
- Use the largest connections and hoses possible to expedite the process.
- J. Charge with clean ,new or reclaimed R-22 refrigerant .Charge in accordance with proper charging procedures.
- K. Check ,and change as needed ,after 24 hours of run time to verify the unit is free of acid.
- 7. Other Check Points
 - A. Verify the operating voltage is within the specified range.
 - B. Check that all wiring connections are tight and proper.
 - C. Verify that all fuses or circuit breakers are of the proper type.
 - D. Ensure the air conditioning operates properly in cooling.
 - E. Inspect all the other electrical components for proper operation.
 - F. Ensure the thermostat and subbase are correct and operate properly.
 - G. Ensure all ducts and air moving device are sized and operate properly.
 - H. Ensure the refrigerant piping is sized correctly and not pinched.
 - I. Ensure all the system are in correct position.

10.3 Troubleshooting Guide

! WARNING – Disconnect all electrical power to the unit before servicing. Disconnect power to both the indoor and outdoor units. NOTE: There may be more than one electrical disconnect switch. Failure to shut off power can cause electrical shock resulting in personal injury or death.

Symptom	Possible Cause	Remedy
No cooling	Power off or loose electrical connection	Make sure main switch is ON. Check and tighten all connections.
	Incorrect thermostat setting	Set thermostat correctly
Insufficient Cooling	Dirty filters	Clean & replace
	Indoor air blockage	Check supply registers and return grills for blockage.
	Blocked outdoor coil	Clear away leaves and other debris
	Improperly sized unit	Recalculate load
	Improper airflow	Check – should be 400CFM/Ton
	Incorrect refrigerant charge	Charge correctly per instruction.
	Air, non-condensable or moisture in system	Recover refrigerant, evacuate & recharge, add filter drier
Incorrect voltage	At compressor terminals, voltage must be within 10% of rating plate volts when unit is running.	
Water on floor or in furnace	Blocked condensate drain and “P” trap	Remove blockage
Condenser fan and compressor don't run	AC Contact not connect to the power supply wire or not tightly fasten.	Re-connect the power supply wire ,and tightly fasten.
	The outdoor power supply main circuit switch locate “OFF” position or fuse failure of main circuit	Dial the power supply switch to “ON ” position or change the fuse and make sure the main touch point of AC Contactor have current go through
	The control coil of AC Contactor no 24 V AC power	Check if the relay P2 of 3-minute timer board have current output ,if not ,check if P1、 P3 have 24 V AC input , if have 24V AC , please check if it keep for 3 minutes, if so and P2 no output , change the 3-minute timer board; if keep time < 3 minutes , P2 no output ; if P1 、 P3 no24V AC, first check the thermostat C 、 Y terminal have 24 V AC, if no 24 V AC, then check the thermostat or reset the setting temp.; if have 24 V AC ,check if the C Y and P1、 P3 connection wire cut off or fasten loosely, if cut off , then change the parts.

Condenser fan runs, compressor doesn't	Run or start capacitor defective	Replace
	Loose connection	Check and tighten all connections.
	Compressor stuck, grounded or open motor winding, open internal overload	Wait for 2 hours for overload to reset. Replace compressor if still open.
	Low voltage condition	At compressor terminals, voltage must be within 10% of rating plate volts when unit is running.
compressor runs, Condenser fan doesn't	Low voltage condition	Add start kit components
	Run capacitor defective	Replace
	Loose connection	Check and tighten all connections.
	Fan stuck, grounded or open motor winding, open internal overload	Wait for 2 hours for overload to reset. Replace Fan if still open.
	Low voltage condition	At compressor terminals, voltage must be within 10% of rating plate volts when unit is running.
	Defective overload protector	Replace – check for correct voltage
Register sweat	Refrigerant undercharge	Add refrigerant
	Low evaporator airflow	Increase blower speed or reduce restriction – replace air filter
High head – Low vapor pressures	Restriction in liquid line, metering device or filter drier	Replace defective components
	Flowrator piston size too small	Change to correct size piston
	Incorrect capillary tubes	Change coil assembly
High head – High or normal vapor pressures	Blocked outdoor coil	Clear away leaves and other debris
	Refrigerant overcharge	Correct system charge
	Condenser fan not running	Repair or replace
	Air, non-condensibles or moisture in system	Recover refrigerant, evacuate & recharge, add filter drier
Low head – High vapor pressures	Flowcheck piston size too large	Change to correct size piston
	Defective compressor valves	Replace compressor
	Incorrect capillary tubes	Replace coil assembly
Low vapor – cool compressor – iced evaporator coil	Low evaporator airflow	Increase blower speed or reduce restriction – replace air filter
	Operating below 65 °F outdoors	Add low ambient kit
	Moisture in the system	Recover refrigerant, evacuate & recharge, add filter drier
High vapor pressure	Excessive load	Recheck load calculation
	Defective compressor	Replace
Fluctuating head and vapor pressures	Air or non-condensibles in system	Recover refrigerant, evacuate & recharge.
Pulsing noise at metering device or liquid line	Air or non-condensibles in system	Recover refrigerant, evacuate & recharge

11. Wiring Diagram

Heat Pump Wiring Diagram

0010575257

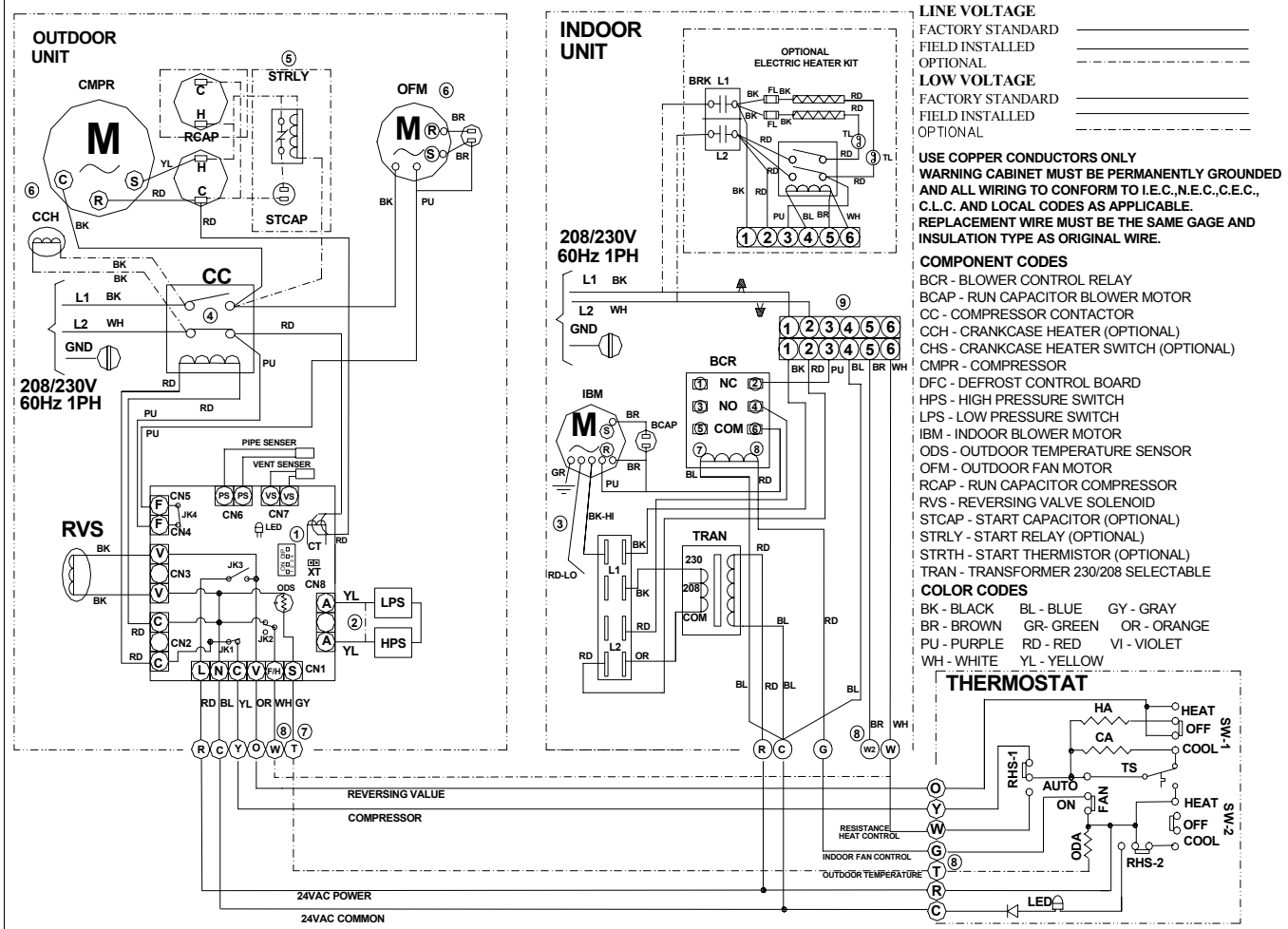

LINE VOLTAGE
 FACTORY STANDARD _____
 FIELD INSTALLED _____
 OPTIONAL _____

LOW VOLTAGE
 FACTORY STANDARD _____
 FIELD INSTALLED _____
 OPTIONAL _____

USE COPPER CONDUCTORS ONLY
WARNING CABINET MUST BE PERMANENTLY GROUNDED
AND ALL WIRING TO CONFORM TO I.E.C.,N.E.C.,C.E.C.,
C.L.C. AND LOCAL CODES AS APPLICABLE.
REPLACEMENT WIRE MUST BE THE SAME GAGE AND
INSULATION TYPE AS ORIGINAL WIRE.

COMPONENT CODES
 BCR - BLOWER CONTROL RELAY
 BCAP - RUN CAPACITOR BLOWER MOTOR
 CC - COMPRESSOR CONTACTOR
 CCH - CRANKCASE HEATER (OPTIONAL)
 CHS - CRANKCASE HEATER SWITCH (OPTIONAL)
 CMPR - COMPRESSOR
 DFC - DEFROST CONTROL BOARD
 HPS - HIGH PRESSURE SWITCH
 LPS - LOW PRESSURE SWITCH
 IBM - INDOOR BLOWER MOTOR
 ODS - OUTDOOR TEMPERATURE SENSOR
 OFM - OUTDOOR FAN MOTOR
 RCAP - RUN CAPACITOR COMPRESSOR
 RVS - REVERSING VALVE SOLENOID
 STCAP - START CAPACITOR (OPTIONAL)
 STRLY - START RELAY (OPTIONAL)
 STRTH - START THERMISTOR (OPTIONAL)
 TRAN - TRANSFORMER 230/208 SELECTABLE

COLOR CODES
 BK - BLACK BL - BLUE GY - GRAY
 BR - BROWN GR - GREEN OR - ORANGE
 PU - PURPLE RD - RED VI - VIOLET
 WH - WHITE YL - YELLOW

①				10SEER	10SEER	12SEER	12SEER	13SEER	13SEER
Dip 1	Dip 2	Dip 3	Dip 4	loop CT twice	loop CT once	loop CT twice	loop CT once	loop CT twice	loop CT once
OFF	OFF	OFF	OFF	HR36A1VAR	HR18C1VAR	HR42C1VAR	HR18D1VAR	HR42D1VAR	
OFF	OFF	OFF	ON	HR18A1VAR	HR42A1VAR	HR24C1VAR	HR48C1VAR	HR24D1VAR	HR48D1VAR
OFF	OFF	ON	OFF	HR24A1VAR	HR48A1VAR	HR30C1VAR	HR60C1VAR	HR30D1VAR	HR60D1VAR
OFF	OFF	ON	ON	HR30A1VAR	HR60A1VAR	HR36C1VAR		HR36D1VAR	

LED Flash Codes(LED illuminates during unit operation only)
 continuous on - 24VAC supplied to Y terminal of defrost control.
 Flash on/off - System in defrost operation.
 1/2+1/2 1 flash - Pipe/coil sensor open or short circuit.
 1/2+1/2 2 flash - Vent/suction sensor short circuit.
 1/2+1/2 3 flash - LPS & HPS open circuit.
 1/2+1/2 4 flash - CT sensor out of max range.

- 1) Confirm defrost control board (DFC) dip switch settings and CT application for system selection as shown in adjacent table. Optional components may be field or factory installed.
- 2) If LPS and/or HPS not installed or removed, a jumper wire must be present across connector CN8 of the defrost control board (DFC) for system to operate.
- 3) For proper system operation, consult indoor unit and outdoor unit installation instructions to confirm system match up and blower speed selection.
- 4) Alternate double pole contactor used on some systems.
- 5) Only one start assist method to be used at a time, consult outdoor unit installation instructions for application information. Use only factory approved accessories.
- 6) Optional OFM components may connect capacitor common and motor common, for reciprocating compressor there may have crankcase heater consult outdoor unit installation instructions for details. Select the running capacitor(one or dual)and connect. If IFM or OFM only have one capacitor wire, connect Com wire to capacitor.
- 7) To protect equipment from operation at low outside ambient temperatures,connect outdoor unit terminal T and equipped indoor thermostat terminal T as shown.
- 8) To activate electric heat circuit during defrost cycle, connect outdoor W terminal to available indoor heat circuit W or W2 .
- 9) Indoor unit shipped without optional electric heater kit. To install optional heater kit, remove power pig tail up to 9 pin plug. Install heater kit and connect with mating 9 pin plug. Run system power connections directly to electric heater kit power terminals. Consult heater kit installation instructions for complete details.

Note: The diagram wiring of the fan motor maybe have some difference from the real parts due to different types of fan motor ,the detailed information can refer to the fan motor nameplate.
 Outdoor Wiring Diagram (HR18A1VAR—HR60A1VAR)

Sincere Forever

Haier Group

Haier Industrial Park, No.1, Haier Road

266101, Qingdao, China

<http://www.haier.com>