

Haier

Central Air Conditioning

SERVICE MANUAL



Models

HR18D1VAR
HR24D1VAR
HR30D1VAR
HR36D1VAR
HR42D1VAR
HR48D1VAR
HR60D1VAR

Part Number:
AC-8888-130

● Features

- Efficient performance and economical operation
- Benchmark hermetic compressor design
- Haier Hi-Efficiency aluminium fin and copper tube design
- Compact design of outdoor unit
- Durable construction
- Quick, easy installation and service
- Heat pump, Premium Series HR13-D1
- Powder coated full metal jacket

CONTENTS

1. DESCRIPTION OF PRODUCTS & FEATURES.....	3
2. PHYSICAL AND ELECTRICAL SPECIFICATIONS.....	5
3. SAFETY PRECAUTION.....	8
4. SYSTEM COMPONENTS AND FUNCTIONS	8
5. ELECTRICAL CONTROL DEVICES.....	10
6. APPLICATION.....	11
7. REFRIGERANT DIAGRAM	13
8. INSTALLATION INSTRUCTIONS.....	13
9. MAINTENANCE INSTRUCTIONS.....	23
10. SERVICE AND TROUBLESHOOTING	23
11. WIRING DIAGRAMS.....	40

! Warning !

The equipment detailed in this manual should be installed and serviced only by qualified technicians who are familiar with the safety procedures required for this work and who have the proper tools, testing equipment and replacement parts.

During testing, it may be necessary to work with circuits with live electrical components. Only individuals with proper training that can follow all electrical safety precautions should perform this work.

Failure to follow all safety precautions could result in property damage, serious injury, or death.

1. DESCRIPTION OF PRODUCTS & FEATURES

1.1 Air conditioning

This manual discusses 'split' central air conditioning and indoor coils. "Split" central air conditioning system refers to the physical location of major air conditioning components. The split system air conditioning are manufactured to standards of quality and performance. They are 13 SEER (Seasonal Energy Efficiency Ratio) which meet or exceed the standards imposed by efficiency legislated and therefore represent both good value today and for years to come. The current air conditioning system use scroll and reciprocating compressors. This gives the air conditioning a durable compressor which needs less external protection, while increasing the unit efficiency in cooling mode.

1.2 NOMENCLATURE FOR MODEL NUMBER

Model number explanation---indoor unit

H	B	24	00	V	A	1	M	20	P
Haier	Blower unit	Nominal capacity in (1000) Btu/h	Electric heater	Electric Designation	Efficiency code	Design series	Airflow configuration	Unit Width(in.)	Continuation
Brand symbol	B:Blower unit C:Evaporator W:Wall mounted unit	24: 24000BTU/h 60: 60000BTU/h	00: No; 05: 5KW; 10: 10KW; 15: 15KW; 20: 20KW	Y:575V-3Ph-60Hz; V:208/230V-1Ph-60Hz; C:208/230V-3Ph-60Hz; D:460V-3Ph-60Hz; A:115V,1 Ph,60Hz	A:10 SEER A/C coil D:13 SEER A/C coil E:14 SEER A/C coil	1: 1st Generation; 2: 2nd Generation;	M:Multi-direction V:Vertical H:Horizontal	17:17"[432] 20:20"[497] 22:22"[559] 25:25"[625]	P: Powder paint E: EC motor

Table 1-1

Model number explanation---outdoor unit

H	R	24	D	1	V	A	R
Haier	System type	Nominal capacity in (1000) Btuh	SEER designation	Design series	Electric Designation	Body style	Reserved
Brand symbol: H: Haier	C: Condensing Unit; R: Heat Pump	24: 24000BTU/h; 60: 60000BTU/h	A:10SEER; B:11SEER; C:12SEER; D:13SEER E:14SEER; F:15SEER; G:16SEER; H:17SEER I:18SEER	1: 1st Generation ; 2: 2nd Generation	A: 115V, 1Ph, 60Hz; C: 208/230V, 3Ph, 60Hz; D: 460V, 3Ph, 60Hz; V: 208/230V, 1Ph, 60Hz; Y: 575V, 3Ph, 60Hz	A: standard style	S=Scroll, R=Reciprocating

Table 1-2

1.3 ENGINEERING FEATURES:

COPPER TUBE/ALUMINUM FIN COILS: Both indoor and outdoor coils are designed and matched to optimize heat transfer while minimizing size and cost, with increased durability and reliability.

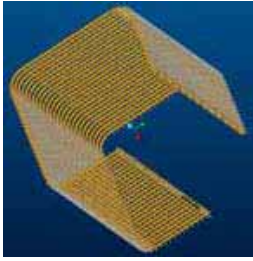

Fig.1-1

CABINETS:

Constructed of powder painted galvanized steel to provide a durable finish and protection for the outdoor coil.



Fig.1-2

FAN GUARD AND MOTOR BRACKET:

Welded powder coated guard with independent rod and band motor bracket, unit top has a deep draw fan venturi for efficient air flow.



Fig.1-3

SERVICE VALVES: Facilitates unit servicing and provides a reliable and safe access to measure unit pressures .



Fig.1-4

BASE PAN: This deep-drawn base keeps the bottom of the coil off the ground, has weep holes to allow for complete drainage.



Fig.1-5

Bi-flow filter drier: Prolong unit life and system reliability by keeping refrigerant clean and dry.

FLOWCHECK DISTRIBUTORS: Outdoor units use the Flowcheck Distributor to act as an open check valve in the cooling mode.

ACCESSORIES:

LOW AMBIENT CONTROL: This factory installed option allows for low temperature operation in the cooling cycle ambient temperatures down to 0°F. This control should be installed in units that operate in cooling when outdoor ambient temperatures below 65°F, and is recommended for all commercial applications.

START COMPONENTS : This option provides additional starting for covering a wide range of voltages and system pressure combinations. This option maybe required on reciprocating compressors with flowcheck piston metering.

SERVICE VALVES AND PRESSURE PORTS: Mounted external to the cabinet for easy access at installation and during service.

2. PHYSICAL AND ELECTRICAL SPECIFICATIONS

Specifications Subject to Change without Prior Notice

Model Number	HR18D1VAR	HR24D1VAR	HR30D1VAR	HR36D1VAR	HR42D1VAR	HR48D1VAR	HR60D1VAR
Comments	1.5-Ton Outdoor HP New Model	2-Ton Outdoor HP New Model	2.5-Ton Outdoor HP New Model	3-Ton Outdoor HP New Model	3.5-Ton Outdoor HP New Model	4-Ton Outdoor HP New Model	5-Ton Outdoor HP New Model
Model Status	New Model	New Model	New Model	New Model	New Model	New Model	New Model
Performance							
with Matching Indoor Unit (Note 3)	HB2400VD1M20 HW18**VD1V22(-P)	HB2400VD1M20 HW24**VD1V22(-P)	HB3600VD1M22 HW30**VD1V22(-P)	HB3600VD1M22	HB4800VD1M22	HB4800VD1M22	HB6000VD1M22-E
Cooling Capacity (Btu/h)	17,500	24,000	28,000	35,000	42,000	46,000	55,000
Net Sensible Capacity (Btu/h)	12600	17280	20160	25200	30240	33120	39600
Net Latent Capacity (Btu/h)	4,900	6,720	7,840	9,800	11,760	12,880	15,400
SEER	13.0	13.0	13.0	13.0	13.0	13.0	13.0
Total Input Watts (Cooling)	1,730	2,180	2,460	3,060	3,800	4,090	5,150
Heating Capacity (Btu/h) (8.3°C)	16,500	22,500	25,500	32,000	41,000	44,000	55,000
Heating COP (8.3°C)	3.3	3.4	3.4	3.3	3.5	3.5	3.4
Heating HSPF	7.8	7.8	7.8	7.8	7.8	7.8	7.8
Total Input Watts (Heating)	1460.0	1940.0	2200.0	2840.0	3430.0	3680.0	4740.0
Airflow Rate (CFM)	1800	1800	2700	3200	3600	4000	4300
Electrical							
Voltage - Phase - Frequency (Hz)	208/230 - 1 - 60	208/230 - 1 - 60	208/230 - 1 - 60	208/230 - 1 - 60	208/230 - 1 - 60	208/230 - 1 - 60	208/230 - 1 - 60
Minimum Circuit Amps	8.6	11.6	12.8	16.1	20.6	21.7	33.7
Maximum Overload Amps	15	20	20	25	35	35.0	55
Compressor							
Type / Maker	Reciprocating H20J153ABCA	Reciprocating H20J213ABCA	Reciprocating H20J223ABCA	Reciprocating H20J293ABCA	Reciprocating H20J383ABCA	Reciprocating H20J403ABCA	Scroll H23R543ABCA
Model Number	H20J153ABCA	H20J213ABCA	H20J223ABCA	H20J293ABCA	H20J383ABCA	H20J403ABCA	H23R543ABCA
RLA (Rated Load Amps)	6.2	8.6	9.2	11.7	14.9	15.8	25.0
LRA (Locked Rotor Amps)	41.0	60.0	60.0	73	90.0	90.0	150.0
Internal Overload Protection	Yes	Yes	Yes	Yes	Yes	Yes	Yes
Crankcase Heater	Yes	Yes	Yes	Yes	Yes	Yes	N/A
Fan Motor							
RLA (Rated Load Amps)	0.86	1.1	1.3	1.43	2.0	2.0	2.5
Rated Horse Power (hp)	1/8	1/6	1/4	1/3	1/3	1/3	1/2
Nominal RPM	1000	840	850	1070	960	880	1000
Input Watts	180.0	200.0	280	310	340	390	510
Fan							
Diameter (In)	18"	23"	24"	23"	24"	24"	24"
No. of Blade	3	3	3	3	3	3	3
Fan Material	Zinc-Coated Steel	ALUMINIUM	ALUMINIUM	ALUMINIUM	ALUMINIUM	Plastic-Coated Steel	Plastic-Coated Steel

Condenser coil		1	1	1	1	1	2	2
Number of Rows		1	1	1	1	1	2	2
Tube spacings (V x H) (In)		1 x 0.85	1 x 0.85	1 x 0.85	1 x 0.85	1 x 0.85	1 x 0.85	1 x 0.85
Fins per Inch - FPI		21	21	21	21	17	17	21
Fin Type		Enhanced fins	Enhanced fins	Enhanced fins	Enhanced fins	Enhanced fins	Enhanced fins	Enhanced fins
Tube OD and Type		3/8" Grooved	3/8" Grooved	3/8" Grooved	3/8" Grooved	3/8" Grooved	3/8" Grooved	3/8" Grooved
Gross Finned Face Area (Sq Ft)		10.8	16.0	18.4	18.4	18.4	20.9	25.8
Number of Circuits (In/Out)		4/4	4/4	5/5	5/5	7/7	9/9	10/10
Exterior Appearance								
Cabinet color		White	White	White	White	White	White	White
Top cover		Stamped sheet metal	Stamped sheet metal	Stamped sheet metal	Stamped sheet metal	Stamped sheet metal	Stamped sheet metal	Stamped sheet metal
Basepan		Deep Drawn, Elevated	Deep Drawn, Elevated	Deep Drawn, Elevated	Deep Drawn, Elevated	Deep Drawn, Elevated	Deep Drawn, Elevated	Deep Drawn, Elevated
Service panel		Easy Access	Easy Access	Easy Access	Easy Access	Easy Access	Easy Access	Easy Access
Body style / Wire grill		Yes	Yes	Yes	Yes	Yes	Yes	Yes
Coil guard		Optional	Optional	Optional	Optional	Optional	Optional	Optional
Plastic mesh		Optional	Optional	Optional	Optional	Optional	Optional	Optional
Features Lug.								
Galvanized Steel Cabinet		Yes	Yes	Yes	Yes	Yes	Yes	Yes
Coil Design		Haier Enhanced Coil	Haier Enhanced Coil	Haier Enhanced Coil	Haier Enhanced Coil	Haier Enhanced Coil	Haier Enhanced Coil	Haier Enhanced Coil
Fully Enclosed Motor		Yes	Yes	Yes	Yes	Yes	Yes	Yes
Removable Top Grill Assembly		Yes	Yes	Yes	Yes	Yes	Yes	Yes
Elevated Base Pan		Yes	Yes	Yes	Yes	Yes	Yes	Yes
High and Low Pressure Switches		Yes	Yes	Yes	Yes	Yes	Yes	Yes
Filter Dryer		Yes	Yes	Yes	Yes	Yes	Yes	Yes
Full, Reusable Service Valves		Yes	Yes	Yes	Yes	Yes	Yes	Yes
Easy Service Access		Yes	Yes	Yes	Yes	Yes	Yes	Yes
Corrosion Resistant Outside Screws		Yes	Yes	Yes	Yes	Yes	Yes	Yes
Accessories								
Room Thermostat		Optional	Optional	Optional	Optional	Optional	Optional	Optional
Start Assist Kit		No	No	No	No	No	No	No
Low Ambient Kit		Optional	Optional	Optional	Optional	Optional	Optional	Optional
Compressor Time Delay		No	No	No	No	No	No	No
Compressor Blanket Kit		No	No	No	No	No	No	No
Fan Delay Kit (Note 1)		No	No	No	No	No	No	No
Piston		Yes	Yes	Yes	Yes	Yes	Yes	Yes
Dimensions and Installation								
Unit Height		32 1/5	28 1/4	32 3/16	32 3/16	32 3/16	36 1/8	44
Dimensions Width (Inches)		23 3/8	30 5/8	30 5/8	30 5/8	30 5/8	30 5/8	30 5/8
Depth		23 3/8	30 5/8	30 5/8	30 5/8	30 5/8	30 5/8	30 5/8
Cubic Volume (Cu. Ft)		10.18	15.33	17.46	17.46	17.46	19.60	23.87
Liquid Line Dimension (In)		3/8"	3/8"	3/8"	3/8"	3/8"	3/8"	3/8"
Vapor Line Dimension (In)		3/4"	3/4"	3/4"	3/4"	3/8"	7/8"	7/8"
Max Refrigerant Line Length (Ft)		115	115	115	115	115	115	115
Refrigerant Line		Max Vertical Distance Indoor above Outdoor (Ft)	70	70	70	70	70	70
		Unit	50	50	50	50	50	50



Central Air Conditioning

Model: Heat Pump, HR13-D1

Service Valves	Re-usable Sweat	Re-usable Sweat	Re-usable Sweat	Re-usable Sweat	Re-usable Sweat	Re-usable Sweat
Refrigerant Connection Type	Orifice (059/062)	Orifice (078/071)	Orifice (085/081)	Orifice(097/081)	Orifice(097/081)	Orifice(096/081)
Metering device (Piston size)/Cooling /heating	R-22 / 125	R-22/117	R-22/133	R-22/186	R-22/196	R-22/314
Refrigerant Type / Charge (Oz) <small>(Note 2)</small>	10" sides/18" service	10" sides/18" service	10" sides/18" service	10" sides/18" service	10" sides/18" service	10" sides/18" service
Min Clearances						
Weight (lbs)						
Net	167.0	203.0	207.0	258.0	271.0	315.0
Ship	178.0	218.0	225.0	275.0	289.0	325.0
Agency Approvals						
Performance Certification	ARI	ARI	ARI	ARI	ARI	ARI
Safety Approvals	UL/cUL	UL/cUL	UL/cUL	UL/cUL	UL/cUL	UL/cUL
Packaging						
Carton Type	Basiloid	Basiloid	Basiloid	Basiloid	Basiloid	Basiloid
Shipping						
Height	33 1/8	29 1/2	33 1/2	33 1/2	37 1/2	45 5/16
Width	25	32 1/2	32 1/2	32 1/2	32 1/2	32 1/2
Depth	25	32 1/2	32 1/2	32 1/2	32 1/2	32 1/2
Cubic Volume (Cu. Ft)	11.98	18.03	20.48	20.48	22.92	27.7
Warranty(Haier Brand Only)						
Parts	5	5	5	5	5	5
Compressor	5	5	5	5	5	5
Noise level dB(A)	65.5	63.5	66.7	68.6	69.7	66.2

Notes:

- 1- 120-second fan delay for air handler
- 2- R-22 Charge for the outdoor unit with matching indoor unit and 25' line set.
- 3- "" in the HWAir Handler model is stand for 00, 05, 08 or 10. For example, for HR18D1VAR, the matching Air Handler can be HW1800VD1V22(-P), HW1805VD1V22(-P), HW1808VD1V22(-P) and HW1810VD1V22(-P)

3. SAFETY PRECAUTIONS

CAUTION: please read all instructions prior to installing, operating, maintaining or repairing the product.

WARNING: THE MANUFACTURER'S WARRANTY DOES NOT COVER DAMAGE TO CAUSED BY THE USE OF ANSUTHORIZED COMPONENTS OR ACCESSORIES, THE USE OF SUCH UNAUTHORIZED COMPONENTS OR ACCESSORIES MAY ENDANGER LIFE AND PROPERTY. THE MANUFACTURER DISCLAIMS ANY RESPONSIBILITY FOR SUCH LOSS OR INJURY RESULTING FROM THE USE OF SUCH UNAUTHORIZED COMPONENTS OR ACCESSORIES

- Always use industry-recognized service practices in the maintenance, adjustment and repair of the products covered in this manual.
- Always wear safety glasses when handling refrigerant and peforming brazing operations.
- Follow the manufacturer's instructions when making repairs, installing replacement parts and performing system maintenance.
- Use only authorized factory parts.

4. SYSTEM COMPONENTS AND FUNCTIONS

This section describes the various air conditioning components, their purpose and operation. This section is only a guide and does not consider all components that could be found on an air conditioner in the field.

COMPRESSORS (Fig. 4-1)

The heart of any refrigerant system is the compressor. It is a pump that causes refrigerant to flow. There are several different types of compressors, but all use electricity to turn an electric motor to drive a pump. Central air conditioners use two types of compressors. The first is the enhanced reciprocating compressor. it operates with an offset crankshaft and pistons, and resembles an internal combustion engine. the driving force is supplied by an electric motor turning the crankshaft and forcing pistons up and down in cylinders where valves control the flow of refrigerant. The valves provide a seal between high and low pressure sides of the system. If the valves are damaged, the compressor's function and efficiency is reduced.



Reciprocating type compressor



Scroll type compressor

Fig.4-1

Generally, liquid refrigerant is suspected if valve damage occurs. Some compressors can tolerate the presence of small amounts of liquid refrigerant in the return gas, but this condition must be avoided through proper refrigerant control. Returning refrigerant cools the compressor motor and surrounding the motor with low pressure gas gives it the name of "low-side" shell compressor

The scroll compressor used a helix (similar in shape to a snail shell) to move refrigerant. When paired within a similar stationary helix, the moving helix rotates so that the space between the two constantly decreases as the gas moves toward the center of the Scrolls. The returning refrigerant gas first cools the motor, then flows into the suction intake of the compressor scroll. The discharge gas leaves from the center of the helix and exits the compressor. The lower part of the shell should be cool to the touch.

Current single phase units use two types of compressors. The design of the two compressors types is quite different. But they function the same way. Scroll units do not need start components or crank-case heaters. The reciprocating compressor may need both. Both types benefit from using a time-delay. time delays prevent thermostat short cycling and momentary power interruptions from damaging the compressor.

Both compressor types are protected internally against over-current and over-temperature conditions. Some scroll compressors have an additional thermostat mounted externally in series electrically with the contactor coil.

FAN AND BLOWER MOTORS (Fig. 4-2 and Fig. 4-3)

The outdoor component of split system contains an fan motor. These PSC (permanent split capacitor) motors are single speed and drive a propeller fan. The motor mounts to the unit top with the shaft up, This fan pulls outdoor air through the outdoor coil.



Fan
Fig.4-2

To access the condenser fan or motor, carefully remove the unit top, a service loop is provided on the motor wiring for easier access.



Fan and motor assembly
Fig4-3

METERING DEVICES (Fig. 4-4)

Flow-Check Pistons

One type of refrigerant metering device is the flow-check piston. It has two functions. First it acts as a refrigerant metering device controlling refrigerant flow into the evaporator. Second, it acts as an open check valve when refrigerant flows in the opposite direction.

When refrigerant enters the device from the square end, the piston seats and forces all refrigerant through the carefully sized hole in the center of the piston. This orifice functions as a metering device controlling the amount of refrigerant flow, with flow in the opposite direction, pressure moves the piston off the seat and liquid refrigerant flows around the piston.

Using too small a piston starves the coils of refrigerant. A piston that is too large floods coils.

Mismatching indoor and outdoor units of split systems affects performance, efficiency, charging and reliability.

PROPER MATCH OF UNIT AND PISTON SIZES

Split air conditioning indoor and outdoor units must be carefully matched to balance the heat transfer indoors with the heat rejected or claimed by the outdoor unit. Manufacturer's specification sheets and installation manuals should be followed to insure proper match. Matched systems are listed on the internet at ARI. ORG.

Combinations for indoor and outdoor units using a distributor and flowcheck are shown in the application table 6-2.



Distributor assy
Fig.4-4

REFRIGERANT CIRCUIT (Fig. 4-5)

All 13SEER units outdoor coils are multi-circuit. Refrigerant gas or liquid is uniformly distributed to from 4 to 10 circuits to improve heat transfer and reduce capacity losses due to pressure drops.

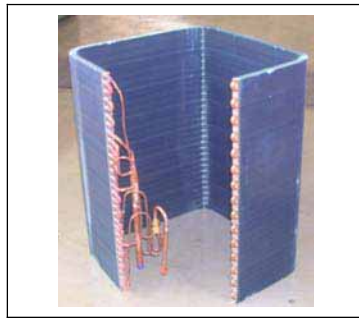

Fig.4-5

SERVICE VALVES

There are two types of service valve used on these air conditioning units. They are the service port valve or "Schrader valve" and the refrigerant line valve. The Schrader valve is like a valve in an automobile tire. The stem or core is removable with a flexible seal at its base held closed with a spring. Schrader valves allow a technician to connect gages to the system with a minimum loss of charge. Use a cap with an inner seal to prevent leakage and keep dirt and moisture from entering the system.

Refrigerant control valves allow the outdoor unit to be isolated into from the balance of the system. In split systems, these valves also hold the charge in the outdoor section from factory.

5.ELECTRICAL CONTROL DEVICES**THERMOSTATS**

Thermostats are the most obvious control in the air conditioning system because these controls are accessible by the consumer. Contact your local distributor for information on part numbers of various manual changeover, auto changeover and set-back thermostats or see the thermostat and subbase selection information found in the wiring diagram booklet.

In the cooling mode, the thermostat calls for cooling by energizing the compressor contactor and the indoor blower control. The indoor blower can operate continuously by setting the thermostat subbase fan switch to the "ON" position.

PROTECTION DEVICES

Protection for the unit begins with the installation of appropriate fuses or circuit breakers by the installing contractor. Breaker or fuse size is governed by the National Electrical Code and local code. AMP draw requirements for each unit are found in the Specifications.

OVERLOADS AND LIMITS

Overloads protect against over-current or over-temperature conditions. Those located in the outdoor unit include the automatic reset internal overload in the fan motor and the compressor automatic reset internal overload. Such controls are not serviceable but their operation may influence service troubleshooting .For example, the compressor internal overload may stay open for several hours .A technician may incorrectly diagnose this as an open compressor winding.

HIGH PRESSURE CUT OUT SWITCH (optional) (Fig. 5-1)

The high pressure cut-out is a pressure activated switch. It opens an electrical circuit when the refrigerant pressure exceeds a pre-determined limit of 440 to 460 p.s.i.g. When pressure becomes normal, the switch restores automatically.



Fig. 5 -1

RELAYS

Relays provide a method for control switching. Relays may switch either low(24VAC) or line voltage. Generally relays used in air conditioning use 24VAC coils. Contact voltage may be either low or line voltage.

COMPRESSOR CONTACTOR

The coil uses 24 volts but the contacts carry line voltage .The heater contactor is a large relay, which controls the compressor and the outdoor fan operation. Some contactor use single pole contacts ,while others use 2-pole or 3-pole contacts.

Single-pole contactors break only one side of the power feed to the compressor and outdoor fan. The other side remains connected to the power source. The 2-pole or 3-pole contactor breaks power to all sides of the compressor and outdoor fan.

CAUTION: WHEN THERE IS A SINGLE POLE CONTACTOR, ONE SIDE OF A 240 V.A.C.CIRCUIT REMAINS HOT. THIS MEANS THAT THE WIRING IN THE HIGH VOLTAGE CIRCUIT MAY HAVE A POTENTIAL OF 120V.A.C.TO GROUD. BEFORE SERVICING THE UNIT, ALWAYS TURN OFF POWDER AT THE UNIT DISCONNECT SWITCH.

OPTIONAL DELAYS AND KITS

A Time-Delay in the compressor contactor lowcontrol circuit allows time for system pressure to equalize before re-starting the compressor.

This delay uses solid state circuitry to measure the time since the power was interrupted and is set for approximately 3 minutes. It is not field adjustable. This is a delay on break timer.

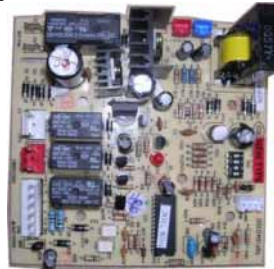

Defrost PCB
Fig.5-2

START KITS(OPTIONAL)

This special relay uses the EMF generated by the compressor start windings to take a start capacitor out of the circuit. The relay and its companion capacitor can start the compressor at low voltages and against higher pressure, such as those caused by non-bleed port expansion valves.

Start kit components should match the recommended ratings and functions of those provided by the reciprocating compressor manufacturer. See Specifications start components.

Start kits are not normally required with scroll compressors. The operating characteristics of the scroll compressor make a start kit unnecessary.

6. APPLICATION

Before specifying any air conditioning equipment, a survey of the structure and a heat gain calculation must be made. A heat gain calculation involves identifying all surfaces and openings that gain heat from the surrounding air and quantifying that heat gain. The heat calculation also calculates the extra heaty load caused by sunlight and by humidity removal. These factors must be considered before selection an air conditioning system to provide year round comfort. The Air Conditioning Contractors of America (ACCA) J Manual method of load calculation is one recognized procedure for determining the cooling load.

The cooling load calculation determines the unit size. There are two capacities that enable the equipment to provide comfort. The first is sensible capacity. Sensible heat is the heat energy measured on the dry bulb thermometer.

The second form of heat is called latent heat. This is heat held by the moisture in the air. Removing this moisture does not affect a thermometer. However, removing the latent heat in the air greatly increase comfort. A properly sized unit removes both forms of heat, producing a comfortable conditions, An oversized system cycles on and off quickly and does not properly remove humidify, producing uncomfortable. The indoor and outdoor equipment combination should be matched by the manufacturer and based on engineering data.

After the proper equipment combination has been selected, satisfying both sensible and latent conditioning requirements, the system must be properly installed. Proper installation with carefully distributed air through adequate duct work will provided a comfortable living space.

There are several factors that installers must consider.

- Outdoor unit location
- Proper equipment evacuation
- Outdoor unit refrigerant charge
- Indoor unit air flow
- Indoor unit blower speed
- Supply and return air duct design and sizing
- System air balancing
- Diffuser and return air grille location and sizing

Unit Dimensions



Model: HR18-60D1VAR

----D1VAR	HR18	HR24	HR30	HR36	HR42	HR48	HR60
D	23-3/8"	30 5/8"	30 5/8"	30 5/8"	30 5/8"	30 5/8"	30 5/8"
W	23-3/8"	30 5/8"	30 5/8"	30 5/8"	30 5/8"	30 5/8"	30 5/8"
H	32 1/5"	28 1/4"	32 3/16"	32 3/16"	32 3/16"	36 1/8"	44"

Table 6-1

Piston sizes and indoor fan speed:

Note: the piston placed in the outdoor unit package box is used for indoor unit when cooling

Outdoor unit	Indoor air handler model		Piston Size (Installed in outdoor)	Piston Size(placed in package bag)	Indoor fan motor speed
HR18D1VAR	HB2400VD1M20	HB2400VD1V20	0.062	0.059	M
HR24D1VAR	HB2400VD2M20	HB2400VD2V20	0.071	0.078	H
HR30D1VAR	HB3600VD1M22	HB3600VD1V22	0.081	0.085	M
HR36D1VAR	HB3600VD2M22	HB3600VD2V22	0.078	0.085	H
HR42D1VAR	HB4800VD1M22	HB4800VD1V22	0.081	0.097	M
HR48D1VAR	HB4800VD2M22	HB4800VD2V22	0.081	0.097	H
HR60D1VAR	HB6000VD1M22-E HB6000VD2M22-E	HB6000VD1V22-E HB6000VD2V22-E	0.081	0.096	H

Table 6-2 Piston size

The air distribution system has the greatest effect. On the quality of the installation and the owner satisfaction, the duct system is totally in the responsibility of the contractor. These are numerous technical associations and reference that recommend correct procedures.

The correct air quantity is critical for correct air conditioning system. Proper operation, efficiency, compressor life and humidity control depend on the correct balance between indoor load and outdoor unit capacity. High indoor air flow reduces system dehumidification capacity, and can leave the space humid and uncomfortable. Low indoor air flow reduces total capacity, and can cause coil icing. Improper air balance will affect system performance and customer's satisfaction and can cause premature component failure.

Air conditioning requires a specified air flow. Each ton of air conditioning requires 400 cubic feet of air per minute (**400CFM/TON**).

Duct design and construction should be done with care. System performance can be lowered dramatically through bad planning or workmanship. In cooling, a hot attic can cause a temperature gain of 3° in the return duct and 4° in the supply duct. This can reduce the cooling capacity of an air conditioning system by as much as 30%. This means a loss of almost one ton of cooling capacity from a three ton system.

Air leakage of only 3% in a return duct can cause a 5% loss in system capacity. 3% leakage on a three ton system is only 30 CFM. Two or three unsealed joints can cause a leak of this size. Sealing the return and supply ducts result in full system capacity and lower operating costs.

Effective duct insulation is essential to prevent loss of capacity and sweating ducts in the cooling mode. Duct systems installed in the conditioned space can be left uninsulated, but a dense 1/2" fiberglass duct liner reduces blower and air noises, and prevents sweating ducts when humidity levels are high.

Supply and return duct systems in attics and crawl spaces require a minimum 1" of dense duct liner or 2" fiberglass wrap with a sealed vapor barrier. A leaky vapor barrier results in duct sweating, causing wet insulation does not insulated.

Heat transfer through poorly insulated systems can result in over 50% loss in operating capacity. Sweating ducts also results in rusting that leads to premature duct failure. Carefully follow the industry practices to insure a well designed duct system.

Air supply diffusers must be selected and located carefully. They must be sized and positioned to deliver treated air along the perimeter of the space. If they are too small for their intended air flow, they can be noisy. If they are not located properly, they can cause drafts in the rooms. Return air grilles must be properly sized to carry air back to the blower. If they are too small they also cause noise. The installers should balance the air distribution system to ensure proper air flow to all rooms in the home. This ensures a comfortable living space.

7. REFRIGERANT SYSTEM DIAGRAM refer Figure 7

8. INSTALLATION INSTRUCTIONS

!WARNING

These instructions are intended as an aid to qualified, service and installation personnel for proper installation adjustment and operation of this unit. Read these instructions thoroughly before attempting installation or service this equipment. **Failure to follow these instructions may result in improper installation, service or maintenance and could possibly result in fire, electrical shock, property damage.**

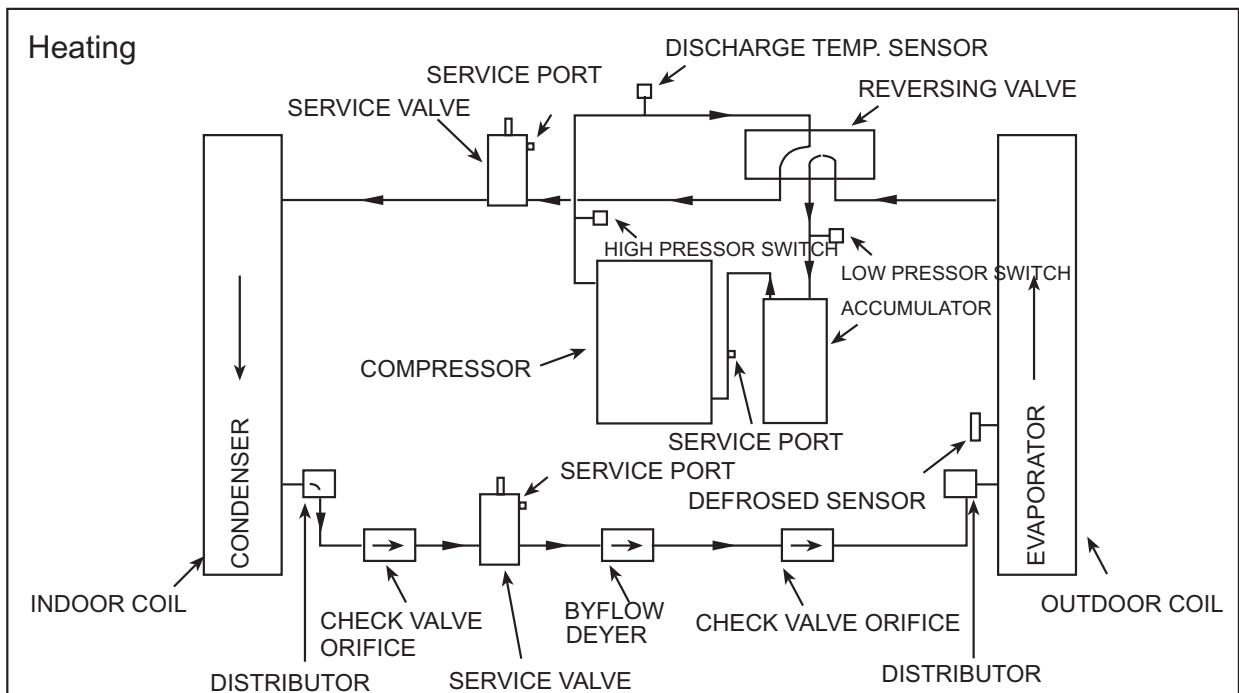
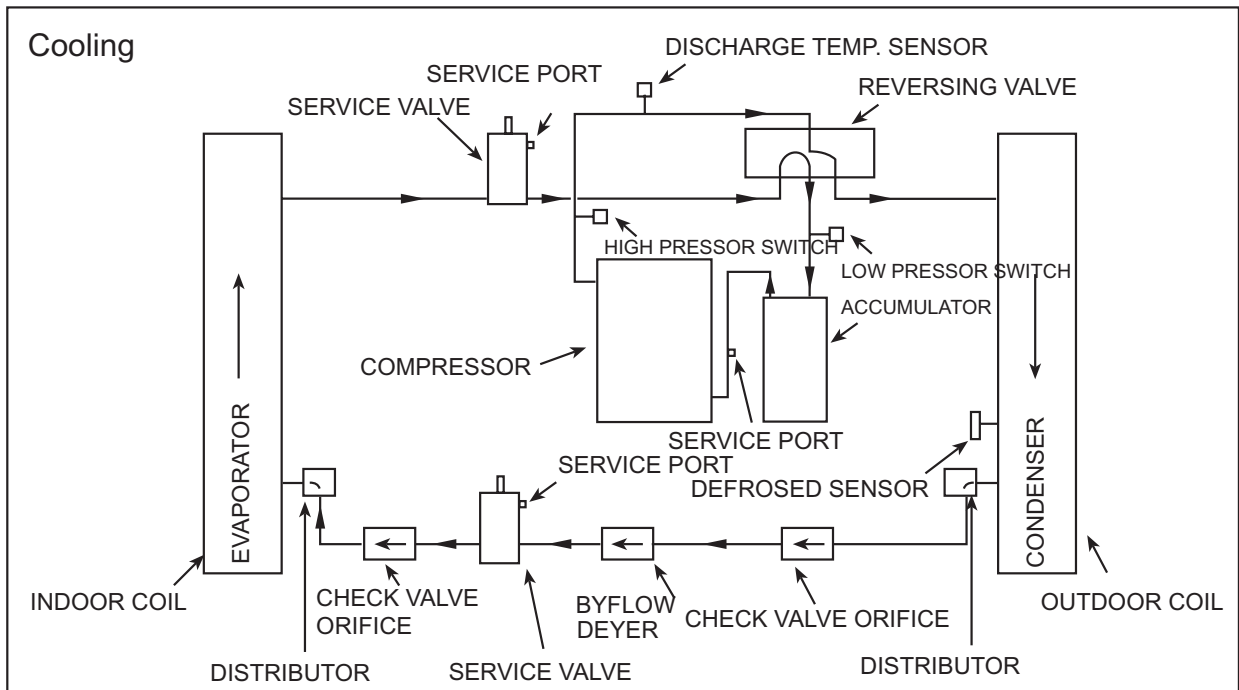

Figure 7 Heat Pump Refrigerant Circuit

This product is designed and manufactured to permit installation in accordance with National Codes. **It is the installer's responsibility to install the product in accordance with National Codes and/or prevailing local codes and regulations.** The manufacturer assumes no responsibility for equipment installed in violation of any codes or regulations.

The United States Environmental Protection Agency (EPA) has issued various regulations regarding the introduction and disposal of refrigerants from this unit. Failure to follow these regulations may harm the environment and can lead to the imposition of substantial fines. Because these regulations are subject to revision any repair on this unit should be done by a certified technician.

The manufacturer's warranty does not cover any damage failure caused by the air conditioning system. **You should be aware that the use of unauthorized components, accessories or devices may adversely affect the operation of the air conditioner and may also endanger life and property.** The manufacturer disclaims any responsibility for loss or injury due to the use of such unauthorized components, accessories or devices. **Attach the service panel to the outdoor unit after to prevent.** If the service panel is not attached securely, it could result in a fire or an electric shock due to dust, water, etc.

8.1 OUTDOOR UNIT INSPECTION

This product has been inspected at the factory and released for shipment without known damage. Inspect exterior of carton for evidence of rough handling in shipment. Unpack carefully. If damage is found, report immediately to you distributor or the transportation agency.

8.2 EQUIPMENT PROTECTION FROM ENVIRONMENT

The metal parts of the unit may be subject to rust or corrosion in adverse environmental conditions. This oxidation could shorten the unit life. Salt spray or mist in seacoast areas, sulphur or chlorine from lawn watering systems and various chemical contaminants from industries such as paper mills and petroleum refineries are especially corrosive.

If the unit is to be installed in an area where contaminants are likely to be a problem, special attention should be given to the equipment location and exposure.

Avoid having lawn sprinkler heads spray directly on the unit cabinet.

In coastal areas, locate the unit on the side of the building away from the waterfront.

Shielding provided by fence or shrubs may give some protection.

Regular maintenance will reduce the buildup of contaminants and help to protect the unit's finish.

! WARNING- Disconnect all electrical power to the unit before servicing. Disconnect power to both the indoor and outdoor units.

NOTE: There may be more than one electrical disconnect switch. Failure to shut off power can cause electrical shock resulting in personal injury or death.

(1) Frequent washing of the cabinet, fan blade and coil with fresh water.

(2) Regular cleaning and waxing of the cabinet with automobile wax.

(3) An appropriate coil cleaner may be used once per year to remove matter that will not wash off with water.

The best protection is frequent cleaning and avoiding exposure to debris that blocks airflow.

8.3 INSTALLATION

These units are designed for outdoor installation. They can be mounted on a slab or rooftop. It is the installer's responsibility to insure that the unit is installed in accordance with all local codes.

Check the following points before beginning any installation:

Structural strength of supporting members.

Clearances and provision for servicing.

Power supply and wiring.

Consideration be given so that operating sounds will not disturb owner or neighbors.

Location with no risk of combustible gas leakage.

Location where natural water drainage does not collect around the unit.

Location where roof runoff does not pour directly on the unit.

Provide gutters or other shielding at roof level.

Avoid locating the unit in an area where excessive snow can accumulate or drifting occur.

Locate unit on a level concrete slab or prefabricate pad. To prevent transmission of noise or vibration, slab should not be connected to building structure. Some sort of sound-absorbing material such as rubber and cork pad should be placed between the condenser and the slab.

For rooftop application, make sure the building construction can support the weight and that proper consideration is given to the weather-tight integrity of the roof. The condensing unit contains moving parts and can vibrate, so, sound transmission is also a consideration in rooftop applications.

! WARNING - Install the unit securely in a place that can bear the weight of the unit. When installed in an insufficiently strong place, the unit could fall causing injury.

8.4 UNIT CLEARANCES

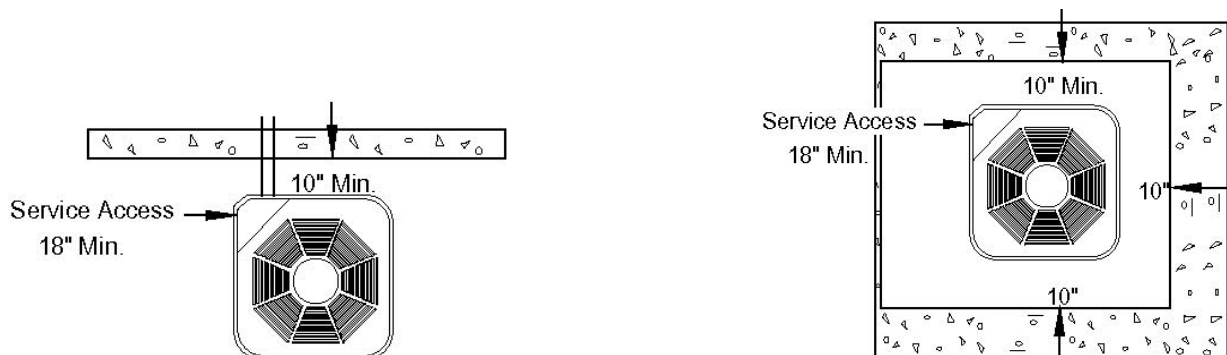

Fig. 8--1

The minimum clearances for the unit are shown in **Fig. 8--1**. Condenser air enters from all (4) sides. Air discharges upward from the top of the unit. Refrigerant line and electrical connections are made from the service access area. A typical application will find the unit located about 10" from wall with connection side facing this wall. This application minimizes exposed tubing and wiring and minimizes the traffic around the unit reducing subsequent damage to the installation.

When necessary for confined applications, provide a minimum of 10" clearance on all air inlet sides. For service access to the compressor and control box, allow 18" minimum clearance. Ensure top discharged free from unobstructions. If units must be located under an overhang, there should be a minimum of 36" clearance and provision made to deflect the warm discharge air out from the overhang.

In order to maintain design air flow, owners should be advised to avoid lawn clippings from depositing on the fin coil surface and reducing the system performance.

8.5 REFRIGERANT PIPING

Properly sized and installed refrigerant piping is very important for the efficient operation of the air conditioning system.

Note the following guidelines:

1. The total run, both vertical and horizontal, should be less than 50 feet or line size correction may be necessary.
2. If the vertical separation exceeds 10 feet use the next larger liquid line size .

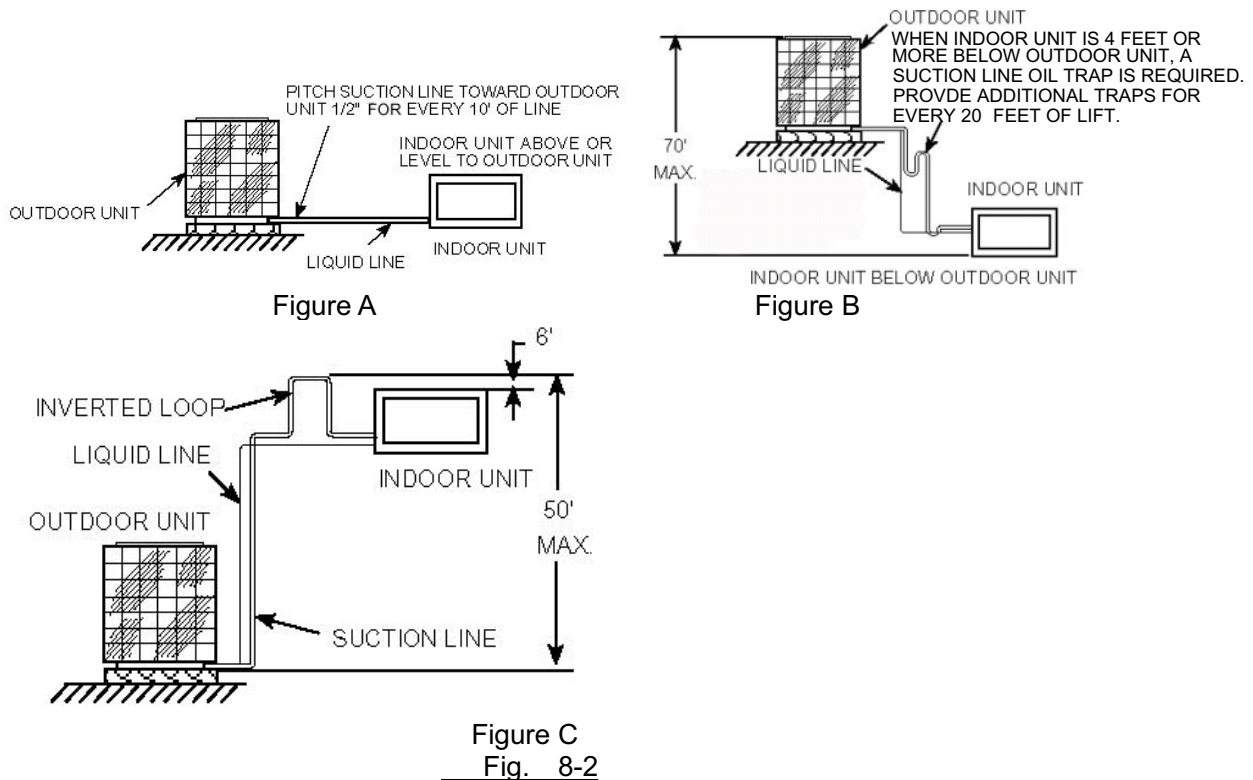

Only refrigeration-grade copper piping (dehydrated and sealed) should be used. **Take extreme care to keep the refrigerant tubing clean and dry prior to and during installation.** If there is any doubt on the cleanliness of the piping, blow out the line with dry nitrogen to remove any chips or debris before connection are made. Always keep tubing sealed until the connections are to be made.

Refrigerant piping should be as short as possible, with a minimum of elbows or bends, to avoid capacity loss and increased operating costs.

Refrigerant lines must be adequately supported. If metal strapping is used to secure the tubing, do not allow the strapping to directly contact the tubing. Use a closed cell insulation to separate the strapping from the tubing. Do not kink or twist the tubing.

Refrigerant piping should not be installed in a cement slab, as this limits access to the refrigerant should a leak be suspected.

Note: To ensure good oil return to the compressor, it is important to pitch the horizontal suction line toward the compressor, approximately 1/2" for every 10' of line.

8.6 Line Insulation

Suction line must be insulated in order to prevent condensation from forming on the piping and to reduce heat gain from the surrounding air. Generally 3/8" wall thickness of Armaflex or equivalent is satisfactory. In severe applications (hot, high humidity areas) greater thickness may be required. Apply the suction line insulation by sliding it on the sealed tubing before cutting and making connections.

Liquid lines do not necessarily need insulation, however, if they are run in high ambient spaces such as kitchens, boiler rooms, hot attics or on the roof, then, they should be insulated as well. Make sure to use proper size copper tubing for the liquid line to prevent liquid refrigerant flashing.

Keep the vapor line and liquid line separated. To prevent an undesirable heat transfer and capacity loss.

Refrigerant Line Sizing

Check the following table (**Table 8-1**) for correct suction and liquid line sizes for any combination of the unit size and the maximum refrigerant line length.

Refrigerant Line Sizing

Unit Size (Ton)	Refrigerant Line Length (Ft)					
	0 – 24		25 – 49		50 – 74	
	Line Outside Diameter (In)					
	Suction	Liquid	Suction	Liquid	Suction	Liquid
1.5	3/4	3/8	3/4	3/8	7/8	1/2
2.0	3/4	3/8	3/4	3/8	7/8	1/2
2.5	3/4	3/8	3/4	3/8	7/8	1/2
3.0	7/8	3/8	1 1/8	3/8	1 1/8	1/2
3.5	7/8	3/8	1 1/8	3/8	1 1/8	1/2
4.0	7/8	3/8	1 1/8	3/8	1 1/8	1/2
5.0	7/8	3/8	1 1/8	3/8	1 1/8	1/2

Table 8-1

Note: The factory charge is sufficient for 25 feet of standard liquid line. For longer or shorter liquid line lengths, adjust the charge as follows:

- 1/4" Line +/- 0.3 oz. Per foot
- 5/16" Line +/- 0.4 oz. Per foot
- 3/8" Line +/- 0.6 oz. Per foot
- 1/2" Line +/- 1.2 oz. Per foot.

Vertical Separation between Indoor and Outdoor Units

Maximum allowable vertical separations between indoor and outdoor units are illustrated in **Fig. 8-2-B and Fig. 8-2-C**. When the indoor unit is below the outdoor unit (Fig.8-3-B), and 50' when the indoor unit is above the outdoor unit (Fig. 8-2-C).

To ensure good oil return to the compressor when the indoor unit is below the outdoor unit, suction line oil trap should be used as illustrated in Fig. 8-2-B.

Interconnecting piping

! CAUTION - Use caution when removing the service valves caps from the suction and liquid line fittings, as there is pressure present. A fitting is on the liquid line to remove pressure.

! CAUTION - Condensing units ship from the factory with an operating refrigerant charge. Heat pump unit liquid and suction valves are closed to contain the charge within the unit. Do not force the valve stem against the retaining ring. If the valve stem is backed out past the retaining ring, system pressure could force the valve stem out of the valve body and possibly cause personal injury.

Instructions on the interconnecting piping and valve opening procedure are listed below:

1. Tubing should be cut square. Make sure it is round and free of burrs at the connecting ends. Clean the tubing to prevent contamination from entering the system.
2. Make sure that both refrigerant shutoff valves at the outdoor unit are closed.
3. Push the tubing into the fitting until it stops. This prevents flux from getting into the system.
4. Remove the cap and Schrader valve core from the service port to protect the valve seals.
5. Wrap a wet rag around the valve stub before brazing.
6. Braze the joints of interconnecting piping. Purge piping with dry nitrogen through the shutoff valve port while brazing.
7. After brazing, quench with a wet rag to cool the joint. Reinstall the Schrader core in the valve, if removed for brazing.
8. Pressurize the lines to 150 psi maximum with dry nitrogen. Check for leaks at all joints with liquid detergent. If a leak is found, repair it after removing the nitrogen. Repeat the process and re-check.
9. Do not purge the lines with refrigerant.

Evacuation

All refrigerant systems must be evacuated to a deep vacuum to remove all noncondensable gases and moisture prior to charging the system. Air in a system increases condensing pressure, which increases power consumption and reduces performance. The presence of moisture in a system leads to premature failure. Proper evacuation assures a dry, uncontaminated system.

Recommended Evacuation Procedure:

1. Connect vacuum pump to both liquid and suction valve service ports.
2. Evacuate the interconnecting tubing and indoor coil to a level of 500 microns or less or for a minimum of 30 minutes. Close the valve to the vacuum pump and wait 15 minutes. The vacuum should not rise above 800 microns. If unable to obtain 500 microns, or vacuum rises above 800 microns after a 15 minutes period, discontinue evacuation, pressurize and check for leaks. Repair any leaks found and repeat the step 2.
3. Close valve to the vacuum pump and stop pump.
4. When sure of a tight, well evacuated system, charge with refrigerant.

8.7 Charging the System

(For systems with capillary tube or fixed orifice metering device)

Before checking the system charge, make sure that the outdoor unit and indoor coil are an approved match system. For best result, the indoor conditions should be within 2 F of the desired comfort conditions.

! WARNING - Do not vent refrigerant to the atmosphere! It is a violation of federal law to do so. If the refrigerant needs to be removed from a system to correct the system charge, always use a recovery or recycling device.

! WARNING - Service refrigerant carefully, high pressure are present.

1. Fully open both shutoff valves.
2. Connect service gage manifold to the valve service ports, being sure to evacuate lines.
3. Startup the system. Run system at least 10 minutes to allow pressure to stabilize.
4. Temporarily install a thermometer on the vapor line near outdoor unit. Be sure of good contact between thermometer and line. Wrap thermometer with insulating material to assure accurate reading.
5. Refer to **Table 8-2** for proper system superheat. Add charge to lower superheat. Remove charge to raise superheat. Carefully remove gauge.

System Superheat					
Ambient Temperature At Condenser Inlet (°F)	Return Air Temperature (°F)				
	65	70	75	80	85
60	17	25	30	33	37
65	13	19	26	32	35
70	5	14	20	28	32
75	5	10	17	25	29
80		5	12	21	26
85		5	10	17	20
90			7	12	18
95			5	5	5
100				5	5

Table 8-2: System charging table by superheat

8.8 ELECTRICAL WIRING

! WARNING

A means of strain relief must be installed to this appliance at the electrical service entrance.

The interconnecting wires between indoor and outdoor units must be in accordance with the national electric code and all code regulations. Failure to follow these codes or the use of unsupported practices or procedures, could result in damage or personal injury or death.

Do not use temporary power cords and do not connect multiple devices to the same electric circuit. Such could cause a fire or an electric shock due to circuit overloads.

All electrical work should be performed by knowledgeable persons according to national codes, and in accordance with this installation manual.

Ground the unit. According to the national electric code.

Electrical installation consists of power supply wiring to the condensing unit and control wiring between thermostat, indoor unit and the condensing unit. All wiring must be in accordance with National Electrical Code and/or local ordinances that may apply.

(See unit wiring diagram furnished with this instruction).

The condensing unit rating plate and the tables of "Physical and Electrical Specifications /Outdoor Units" (Table 2-1 and 2-2) provide pertinent data necessary for the selection of proper size electrical service and over-current protection devices.

Table 8-3 provides data on the minimum copper wire size as a function of supply wire length and circuit ampacity.

Copper Wire Size - AWG (1% Voltage Drop)				
Supply Circuit Ampacity	Supply Wire Length - Ft			
	50	100	150	200
15	14	10	8	6
20	12	8	6	4
25	10	8	6	4
30	10	6	4	4
35	8	6	4	3
40	8	6	4	2
45	6	4	3	2
50	6	4	3	1

Table8-3: Minimum Wire Size Based on N.E.C. for 60 C Type Copper Conductors Below 100 Ampacity.

The installer must be familiar with the location of the over-current protection, properly size for this this application and the proper procedure for disconnecting power service to the unit.

The location of the disconnect device must be in accordance with local codes.

The outdoor unit control wiring requires a 24 Volt minimum, 25 VA service from the indoor transformer as shown on the wiring diagram.

8.10. SYSTEM STARTUP

1. Turn thermostat to "OFF", turn on power supply at disconnect switch.
 2. Turn temperature setting above the room temperature.
 3. Turn fan switch to "ON". Indoor blower should run. Be sure it is running in the right direction.
 4. Turn fan switch to "AUTO". Turn system switch to "COOL" and turn temperature setting below room temperature. Unit should run in cooling mode.
 5. Check to see if compressor and outdoor fan are running correctly.
 6. Check the refrigerant charge (see Instructions under "Charging the System").
 7. Replace service port caps. Service port cores are for system access only and will leak if not tightly capped.
 8. Check unit for tubing and sheet metal rattles.
 9. Instruct the owner on operation and maintenance.
- Leave this "Installation and Operating Manual" and the "Use and Care Manual" with owner.

8.11. OPERATION

SEQUENCE OF OPERATION

In order to service and troubleshoot a air conditioning system, The service technician must understand the system's sequence of operation. This is the order of events the system undergoes in response to. Understanding the sequence of operation aid in determining where to start troubleshooting when the unit doesn't operate properly. Deviation from the normal operation sequence will provide clues to system problems.

COOLING CYCLE

Mechanical. The operation sequence is as follows:

1. The compressor provides high pressure, superheated refrigerant vapor.
2. The vapor leaves the compressor and passes through the reversing valve.
3. The vapor flows through the outdoor vapor line to the finned outdoor coil. Air from the outdoor fan removes heat from the refrigerant vapor. When enough heat is removed, the vapor condenses into a high pressure liquid. The liquid temperature leaving the outdoor coil is slightly warmer than ambient air temperature.
4. This warm, high pressure liquid leaves the outdoor coil, and flows through the small copper refrigerant liquid line.
5. At the end of the liquid line, the refrigerant passes through a fixed metering device, reducing pressure and temperature .
6. The liquid, under reduced pressure, then enters the indoor coil surface it expands and absorbs heat from the indoor air passing over the finned surface. Heat from the indoor air, causes the low pressure liquid to evaporate and cool the indoor air. The refrigerant has now been converted to cool vapor.
7. The cool refrigerant vapor travels through the larger, insulated vapor line to the accumulator.
8. The accumulator separates any liquid refrigerant and holds it. Only vapor refrigerant and refrigerant oil leave the accumulator. The oil is drawn out through a special port inside the accumulator.
9. Refrigerant vapor flows through the suction line to the intake of the compressor. The cycle then repeats.

Electrical . The operation cycle as follows:

1. The thermostat calls for cooling when the space temperature is above the set point.
2. This sends a 24 voltage signal through the "Y" terminal to the outdoor unit PCB, after 3 minutes the compressor contact in the outdoor unit are closed. The compressor and outdoor fan start.
3. At the same time, a 24 Voltage signal flows through the "G" Terminal to the air handler PCB and indoor blower starts.
4. The cooling system is now in operation.
5. The thermostat satisfies and ends the call for cooling.
6. This ends the 24 Voltage signal to the compressor start kit and the outdoor unit stops.
7. This ends the 24 voltage signal to the indoor blower relay and this indoor blower strips
8. The system is now off.

9. MAINTENANCE INSTRUCTIONS

FILTERS

WARNING: DISCONNECT MAIN ELECTRICAL POWER TO THE UNIT BEFORE ATTEMPTING ANY SERVICE OR MAINTENANCE.

1. The air conditioning system operates most efficiently with clean air filters, check filters monthly to determine how frequently your filters need be cleaned. A new home require more frequent filter attention until dust and fibers from the construction is removed.
2. Replace glass fiber filters when dirty.
3. Clean semi-permanent plastic impregnated fiber filters :
 - A. Vacuum clean; or B: Wash with detergent and water, air dry thoroughly and re-install.

Caution: Do not operate any system without filters

Note: if an electronic air cleaner is installed, remove any mechanical filter from the air handler. Follow the installation and maintenance instructions furnished with the electronic cleaner.

OUTDOOR COIL CLEANING

Keep the outdoor coil clean for full air flow and proper operation .Do not allow leaves, grass clippings or other material to obstruct the coil. Do not allow anything to block the coil. Keep fences, shrubs, or other obstructions at least 24" away from the coil air inlets.

If the coil becomes obstructed or dirty, it may be necessary to clean the coil.

- A. Before cleaning coil, **TURN OFF ELECTRICAL POWER** to the outdoor unit.
- B. Remove the top with the outdoor fan attached.
- C. Flush water through the coil from the inside out.

NOTE: Avoid getting water on any controls or other electrical devices. If electrical components get wet, dry it thoroughly before energizing.

There are many commercial coil cleaning materials developed to clean outdoor coils. Follow the manufacturer's instructions when using these materials. Normally the solvent is sprayed onto the coil. Allow several minutes for the solvent to dissolve any organic matter .Wash away the solvent and any dissolved matter with water from a garden hose.

NEVER USE A WEATHER COVER OVER THE OUTDOOR UNIT. The unit is designed to operate outdoors. A cover traps moisture in the unit causing rust and corrosion .There is the added danger of starting the system with the cover on. This prevent air flow through the outdoor coil causing dangerous system pressure .Compressor damage may result.

10. SERVICE AND TROUBLESHOOTING

WARNING: THE ABILITY TO PROPERLY PERFORM SERVICE ON THIS EQUIPMENT REQUIRES EXPERIENCE, MECHANICAL SKILLS, TOOLS AND TEST EQUIPMENT .IF YOU ARE NOT QUALIFIED, DO NOT ATTEMPT TO PERFORM ANY SERVICE ON THIS EQUIPMENT, CONSULT THE USER'S MANUAL FOR ROUTING MAINTENANCE THAT CAN BE DONE BY THE HOME OWNER.

FAILURE TO FOLLOW THIS WARNING COULD RESULT IN POSSIBLE DAMAGE TO THE EQUIPMENT, SERIOUS PERSONAL INJURY, OR DEATH.

The HVAC industry, had improved the efficiency of the products offered to consumers. New and more sophisticated mechanical and electronic features for achieving higher efficiencies have been designed. The use of test equipment is now more critical than ever.

In the servicing and troubleshooting section is information on compressors and other components and their test procedures. There are troubleshooting charts, charging charts, wiring diagrams and service guide charts. Included is list of suggested test equipment.

This information can be used by the service technician to understand the installation and troubleshooting and operation of the current familie of air conditioning. The procedures in this section are generic in content. Each product family incorporates some of these components. Be aware of this is a guide compiled from numerous sources. It can not take into consideration all conditions found in all installations.

Note: Upon arrival at the job site, a sound first step is a review of the system installation to identify any obvious problems, this **Installation Manual should be used as a guide.**

REFRIGERANT RECOVERY

Refrigerant systems using chlorofluorocarbon (CFC) and Hydrochlorofluorocarbon (HCFC) refrigerants system are subject regulation by **the clean air Act of 1990.** This act prohibits the unrestricted release

of refrigerant into the air. Proper charging of refrigerant system may require removing some refrigerant when the system is overcharged. and is to be used by personnel with appropriate industry experience recover the excess refrigerant.

Recovery means to collect the refrigerant in a special holding container. **Recycling** means to run the refrigerant through a filtering system to remove most particles and moisture. **Reclaiming** means to chemically reprocess the refrigerant to return it to its original purity.

Recovering and recycling refrigerant is possible with the aid of mechanical devices made for the purpose .The recovery system is a compressor / pump assembly, which removes refrigerant from a system and safely stores it in a Department of Transportation (DOT) approved container until it is **re-used or returned for reclaim.**

The authors of the EPA regulations enforcing the Clean Air Act realized that an accidental release of the refrigerant may happen in the course of normal service.

Always use procedures so as not to release any refrigeran.

When performing service on a refrigerant system, charging should be done using the best service practices, ensuing that the least amount of refrigerant needed is used.

Lines must be evacuated before charging with refrigerant.

WARNING : IN ORDER TO COMPLY WITH FEDERAL LAW, ALWAYS USE A RECOVERY / RECYCLINE DEVICE WHEN DOING REFRIGERANT SERVICE.

TEST EQUIPMENT

The following test equipment is recommended to properly service air conditioning equipment:

1. A good quality volt/ohm meter;
2. A two-channel temperature electronic thermometer;
3. A Magnetic Gauge (capable of reading to 3" W.C.)
4. A refrigerant pressure Gauge manifold set;
5. A clamp-on ammeter.
6. An electronic leak detector or bottle of soap suds.
7. A micron meter (not shown)
8. A vacuum pump capable of pulling to 1000 microns;
9. Refrigerant recovery /recycling equipment



vacuum pump
Fig.10-1

Before beginning any troubleshooting procedure, complete the following installation checklist. An equipment problem is sometimes caused by an improper installation. By completing this checklist the problem may be found and corrected. Make copies of the checklist and complete one for every air conditioning system call for your records.

10.1 INSTALLATION AND SERVICE CHECKLIST (Refer to the unit installation instructions for the specifics)

ELECTRICAL

-Correct the thermostat and subbase
-Correct line voltage supplied to indoor and outdoor units
-Proper equipment ground to the electrical panel
-Correct control voltage at outdoor unit and transformer adequate for all control voltage loads
-Proper disconnect switches and breakers for indoor and outdoor units
-Correct wire size for both indoor and outdoor units.

OUTDOOR UNIT INSTALLATION

-Unit level with proper clearances for air flow and service
-Proper elevation of outdoor unit
-Solid pad
-Coil free from dirt and debris
-Unit charged according to manufacturer's instructions
-No evidence of refrigerant leaks

REFRIGERANT LINES

-Proper length according to manufacturer's instructions
-Proper size according to manufacturer's instructions
-Large vapor line insulated
-No inadvertent oil traps and proper sloping
-No kinks or restrictions
-No evidence of refrigerant leaks

INDOOR UNIT INSTALLATION

-Adequate clearances for air flow and service
-Proper supply and return air duct size and design
-Air ducts sealed to prevent leakage
-Correct filter(s)
-External static pressure _____ inches W.C.
- Proper air flow (about 400 CFM per ton)
- Correct indoor coil and accessories
- No evidence of refrigerant leaks
- Condensate line piped with trap and vent
-Horizontal drain pan installed in horizontal applications
- Auxiliary drain pan installed in horizontal applications
- Auxiliary condensate line installed in horizontal application

CAPACITOR ELECTRICAL CHECK

WARNING: ANY CAPACITOR SHOWING SIGNS OF LEAKAGE OR BULGING MUST BE REPLACED IMMEDIATELY. DO NOT OPERATE THE AIR CONDITIONING SYSTEM WITH A CAPACITOR SHOWING THESE SIGNS.

Single phase compressors require a run capacitor connected to the run and start windings. This puts the two windings out of phase from one another and allows the compressor motor to start. Use a capacitor tester to determine if the capacitor dielectric has broken down, or if the MFD value has changed. If a capacitor analyzer is not available, use a quality ohmmeter to check the resistance between the capacitor plates

1. Set the ohmmeter to the highest scale available
2. Discharge the capacitor by shorting the terminals with the blade of a screwdriver having an insulated handle.
3. Place the Ohmmeter probes on the capacitor terminals and observe:
 - A. If the meter pointer moves towards zero, then gradually moves to higher ohm values, the capacitor is GOOD
 - B. If the meter pointer does not move, the Open capacitor is open and should be REPLACED.
 - C. If the meter pointer goes toward ZERO ohms and stays at or near zero, the capacitor is shorted and should be replaced.
4. Replace any failed capacitor with a capacitor having the same MFD and voltage rating.

COMPRESSOR START KITS



Run capacitor
Fig.10-2

Some compressors require the assistance of a hard start kit to start, it is urgent to consult the compressor manufacturer's recommendations for start kits. Follow the manufacturer's installation information.

WARNING: DISCONNECT ALL POWER TO THE OUTDOOR UNIT BEFORE BEGINNING THIS TEST .

MOTORS:
ELECTRICAL

The motors in both the outdoor unit and indoor unit are similar. Outdoor motors have one speed while indoor motors usually are multi-speed. All fan motors require a capacitor for the best torque and efficiency. If the motor is replaced, replace the capacitor at the same time.

The fan motor has both "Run" and "Start" windings. Extended run windings furnish a choice of speeds with indoor products. Use an Ohmmeter to troubleshoot motors.



Indicator
Fig.10-3

ELECTRICAL CHECK TO TEST FAN MOTOR:

1. **Be sure power is off to the motor.**
2. Disconnect the motor wires.
3. Place one ohmmeter lead on **common** and the other on **start**. The meter should show continuity.
4. Place one ohmmeter lead on **common** and the other on **run**. The meter should show continuity with less resistance.
5. Leave one meter lead on **common** and touch each remaining lead. Each should indicate continuity.
6. If a winding does not show continuity, the motor has failed and must be replaced.
7. If the motor needs replacing, replace the capacitor as well.

MECHANICAL

Fan motors can fail for a number of reasons, including failure bearing loss due to a lack of lubrication. This may be caused by excessive water. Lubrication can be washed out of permanently lubricated bearing. If a motor fails, replace it with a similar motor having the same rotation horse power, RPM and electrical

characteristics.

CONDENSER FAN BLADE LOCATION

Dimension "A" will be from 2" to 4" depending on the unit model number. Be sure to check this dimension BEFORE removing the fan blade.

Note: When parts combination results in motor /blade interference ,the fan blade should be located to provide 1/8" motor /blade clearance.

RELAYS

ELECTRICAL OPERATION

Contactors coils are made with copper wires wrapped around a steel core. When energized, the coil generates a magnetic field that moves the steel core to open or close the circuit contacts. Electrical continuity indicates a good coil. Relay coils use specific voltage. Using a contactor with the wrong voltage coil will prevent the system from operating properly. This problem is avoided when using the proper replacement part for a failed component.



Fig. 10-4

Relay contacts are switches and can become pitted or corroded, creating resistance. Resistance can generate enough heat to weld the contacts together. Physical examination of the contacts will reveal this problem. With sealed relays, use an ohmmeter to test for open or closed contacts.



Fig. 10-5

ELECTRICAL CHECKS

1. **BE SURE ALL THE ELECTRICAL POWER IS OFF TO THE COMPONENT BEING CHECKED.**
2. Remove at least one wire from the component being checked.
3. Measure the resistance of the holding coil with an ohmmeter
 - A. A specific resistance indicates a good holding coil.
 - B. Infinite (∞) resistance indicates a relay with an open holding coil. REPLACE the defective relay with an appropriate service part.
4. Measure the resistance across the normally closed (NC) relay contacts.
 - A. The resistance should be zero (0) ohms.
 - B. If the resistance is more than 0.2 ohms the contacts are pitted. REPLACE this relay with an appropriate service part.
5. Measure the resistance across the normally open (NO) relay contacts.
 - A. The resistance should be Infinite (∞)
 - B. If the resistance isn't Infinite (∞), REPLACE this relay with an appropriate service part.

MECHANICAL CHECKS

In relays ,mechanical faults are few. But check relay body for signs of physical damage .

AIR FLOW

Indoor coil air flow in any air conditioning system is critical. Too much air and the system will not be able

to suffers lack of dehumidify in cooling. insufficient air flow while cooling may result in coil freeze up, excessive dehumidification and lost capacity.

Checking air flow is the most important diagnostics a service technician can perform. Instructions are provided to show how to measure pressure drop across the coil. If pressure drop tables are available, they indicate the cubic feet of air per minute (CFM) moving through the coil. An inclined manometer or magnetic gauge can be used for measurement.

A velometer measures the velocity of the air in feet per minute (FPM). If the area of duct is known, the velometer reading times the area of duct (in square feet) calculates the air flow.

If the indoor unit has an electrical heater, air flow can be estimated by measuring the air temperature entering and leaving the heater and calculating the CFM.

$$\text{CFM (Electrical Heater)} = \frac{\text{VOLTS} \times \text{AMPS} \times 3.414}{1.08 \times \text{TEMP RISE}}$$

COMPRESSOR AND SYSTEM FAULT DIAGNOSIS

Compressor manufacturers state that many of the compressors returned as defective have been misdiagnosed. To ensure that does not happen, the technician must determine if the compressor has failed or if another control has either failed or stopped the compressor from operating after detecting a problem. The following procedures should help determine if the compressor has failed.

Prior to replacing a suspected failed compressor, a thorough check must be made of all existing electrical components. If not done, a replacement compressor might also fail or not operate at all.

WARNING: THE FOLLOWING PROCEDURES SHOULD ONLY BE ATTEMPTED BY QUALIFIED SERVICE TECHNICIANS EQUIPPED WITH PROPER TOOLS, SAFETY PROCEDURES AND EQUIPMENT AND INSTRUMENTS TO PERFORM THE DESCRIBED REPAIRS.

COMPRESSOR ELECTRICAL CHECKS

Single-phase compressors use permanent split capacitor motors. There are two windings that connect at a common point at the "common" wiring terminal. The two windings are called "start" and "run". The start winding has the higher resistance and is connected in series with the capacitor. The run winding has the lower resistance and connects directly to the power supply from the compressor contactor.

The design uses a protective device called an "internal overload". If compressor draws high amperages, for an unusually long time or temperatures in the compressor motor, it opens an internal circuit to stop the motor.

ELECTRICAL CHECK COMPRESSORS

1. Consult the unit wiring diagram. Confirm that all electrical wiring for the units is correct and that all wiring connections are right.
2. Measure the available line voltage. On the single phase 208/230 Volt units, this should be from 197 to 253 Volts.
3. Check for proper control voltage at the unit contractor coil. If this voltage is inadequate or is not present, refer to the wiring diagram or the compressor troubleshooting flow chart at the end of this section for possible causes.
4. Disconnect all power from the unit and visually inspect the compressor contactor for pitted or burned contacts.
 - A. This could indicate high or low voltage problems or improper start components.
 - B. Check the contactor coil with an ohmmeter for a short or open circuit.
 - C. Replace the contactor if any fault is noted.

5. WITH THE ELECTRICAL POWER OFF, remove all power wires from the compressor terminals, **MARK THE ORIGINAL LOCATION OF EACH WIRE.**

A. Use an ohmmeter set for the highest scale to check for grounding between compressor motor terminals and a good clean ground such as the compressor shell or copper line.

B. The resistance from any terminal to ground should exceed 1,000,000 ohms.

6. Use an ohmmeter set for the lowest scale and check the continuity of the motor windings. These ohm values are less than ten ohms and in some cases less than one ohm.

A. The ohm reading from the RUN terminal to common terminal is the lowest reading measured between compressor terminals, approximately 1 ohm.

B. The ohm reading from the Start TERMINAL TO COMMON TERMINAL will be the middle ohm value measured between the terminals and be approximately 2.0 to 3.0 ohms

C. The ohm reading from the Start TERMINAL TO Run terminal will be the highest ohm value of the three measurements and will be approximately the sum of the first two measurements.

EXAMPLE:

A. Run to Common -1.0 Ohms
 Start to Run -3.0 Ohms
 Start to Common -4.0 Ohms

Conclusion compressor motor does not have open or shorted windings:

B. Run to Common $-\infty$ Ohms
 Start to Run -3.0 Ohms
 Start to Common $-\infty$ Ohms

CONSLUSION COMPRESSOR COULD HAVE AN OPEN INTERNAL OVERLOAD-ALLOW THE COMPRESSOR MOTOR TO COOL AND THE INTERNAL OVERLOAD TO RESET, THEN RETEST.

C. Run to Common -1.0 ohms
 Start to Run $-\infty$ Ohms
 Start to Common $-\infty$ Ohms

OPEN COMPRESSOR START WINDING---**REPLACE THE COMPRESSOR .**

7.The resistance from one winding terminal to any other terminal should be the same with three phase compressors. **NOTE:** on larger 208/230 volt compressors the ohm values could be as low as 0.10 ohms, THIS IS NOT A SHORTED WINDING .A winding is open if resistance measured is infinite(∞).

COMPRESSOR MECHANICAL CHECKS

Compressors fail mechanically due to bearing failure ,valve failure ,or damage to the internal suspension system. Bearing and valve failure is almost always caused by liquid refrigerant. **COMPRESSORS ARE DESIGNED TO ONLY PUMP REFRIGERANT VAPOR.** Liquid refrigerant damages the valves by deforming or breaking them. Liquid refrigerant also damages bearings by diluting or foaming the lubricating oil.

SYSTEM PUMP DOWN

This procedure tests the compressor valves. It can indicate internal refrigerant leaks such as through the liquid line service valve. The procedure uses the compressor to trap all the refrigerant inside the condensing coil (outdoor cooling). The technician's gauges indicate if the condensing coil holds the refrigerant as intended or if it leaks out.

Procedure

1. Connect the compound refrigerant gauge to a service port that reads suction pressure such as on the compressor shell, or in the line between accumulator and compressor. Connect the high pressure gauge to a service port that reads high pressure .
2. With the unit operating, front seat (close) the liquid line service valve. Observe the gauges .The suction pressure should fall. The high pressure should also fall slightly. If the discharge pressure rises above 400 psi, **Shut off about outdoor unit.**
3. **SHUT OFF THE COMPRESSOR WHEN THE SUCTION PRESSURE DROPS TO 3-5 PSI. POSITIVE PRESSURE. DO NOT OPERATE THE COMPRESSOR WITH A NEGATIVE SUCTION PRESSURE OR IN A VACUUM.**

4. After pump down and compressor stops, observe the suction pressure on the compound gauge.
 - A. The suction pressure holds as steady pressure. **this is a normal condition.**
 - B. Suction pressure rises above the stopping point, but then stops and holds steady. Some refrigerant finally evaporating in the coil, and registering on the gauge. **This is the normal condition.**
 - C. Suction pressure conditions rise and eventually equalizes with the observed pressure on the high pressure guage.

Abnormal condition.

 - Refrigerant is leaking from the condenser coil .
 - Causes** :Leaking liquid line valve, leaking discharge check valve (scroll compressors only), leaking compressor valves.
 - ACTION:** Determine the causes and correct it.
 - D. Unable to reach the 3-5 PSI level for suction pressure. **This is an abnormal condition.**
 - Refrigerant is leaking from the condenser coil .
 - Causes** :Leaking liquid line valve, leaking discharge check valve (scroll compressors only), leaking compressor valves.
 - ACTION:** Determine the causes and correct it..

SYSTEM REFRIGERANT NONCONDENSIBLES CHECK

This procedure checks the quality of the refrigerant by comparing the refrigerant pressure to its temperature. The test tells if there are contaminating non-condensable gases in the refrigerant, usually air or moisture.

1. Pump the system down as the explained in the previous procedure. Open the unit disconnect to SHUT Down the system when the suction pressure drops to 3-5 psi positive pressure .
2. Front SEAT THE LARGE VAPOR LINE VALVE.
3. Disconnect the compressor by **REMOVING EACH WIRE FROM THE COMPRESSOR TERMINALS. MARK AND IDENTIFY THE WIRE TERMINALS WITH THE COPRESPONDING WIRE COLOR CODE.**
WARNING :WRAP A LAYER OF INSULATION ELECTRICAL TAPE OVER THE WIRE TERMINALS , (NOT THE COMPRESSOR TERMINALS) . THESE WIRE ENDS WILL BE AND GNERGISED HOT DURING THE REMINDER OF THE TEST .
4. Close the disconnect switch to the system and run the condensing fan .Measure the condensing coil entering and leaving air temperature with accurate thermometers.
5. Run the condensing fan until the leaving air temperature equals to the entering air temperature. This is now the refrigerant temperature .
6. Compare the observed refrigerant pressure shown on the high pressure gauge to its associated pressure on a temperature –pressure conversion chart.
7. The refrigerant pressure should equal the chart pressure for the observed temperature.
 - A. The system pressure is above the chart pressure. Capital letters: Non-condensales are present -air and/or moisture. **ACTION:** Remove and recover the refrigerant. Evacuate the system and charge with new and correct refrigerant.
 - B. The system pressure is below the chart pressure. Capital letters: A mixed refrigerant is present. **ACTION:** Remove and recover the refrigerant. Evacuate the system and charge with new and correct refrigerant.

COMPRESSOR REMOVAL PROCEDURES

USE THESE PROCEDURES ONLY WHEN YOU HAVE POSITIVELY DETERMINED THAT THE COMPRESSOR HAS EXPERIENCED A MECHANICAL AND/OR ELECTRICAL FAILURE.

CAUTION: After a seveer motor burn-out the products of the burn-out may be acidic. The technician should wear rubber gloves and eye protection to prevent injury when testing refrigerant oil.

Use the following procedure for compressor removal ONLY after determining that the compressor has failed.

1. **DISCONNECT THE MAIN POWER SOURCE TO THE UNIT AND LOCK THE DISCONNECT SWITCH IN THE OPEN POSITION.**
2. Disconnect the electrical wiring at the compressor identifying each wire and its location.
3. Remove the refrigerant charge from the entire system using proper recovery procedures.

4. Remove the failed compressor.
 - A. Unsolder the suction and discharge lines at the compressor stubs.
 - B. Remove the compressor hold down bolts.
 - C. Place the failed compressor on a smooth surface to remove the mounting grommets and sleeves for use with the new compressor .
 - D. Prevent any contamination from entering the refrigerant lines.
5. Conduct an acid test on the oil from the failed compressor .
 - A. Secure a generous sample of oil from the failed compressor.
 - B. Follow the oil test kit instructions to determine the degree of compressor burn out.
 - As a general rule, oil with a test number less than 0.05 indicates a mild burn out.
 - Oil with a test number greater than 0.05 indicates a severe burn-out .
 - Some oil test kits indicate severity by color change .
 - As a guide ,burn out classifications are as follows:
 oil clear, no color, the compressor may have had a mechinial failure and not a burn-out.
 oil clear, slight color, the compressor may have had a mild burn-out .
 oil very dirty, strong odor test >0.05, the compressor may have had severe burn-out.

Note: Dispose of any contaminated refrigerant oil in accordance with all environmental regulations and procedures.
6. Use the following procedures with units suspected of having mild to severe burn outs.
 - A. After compressor removal, insert a clean, lint free swab into the system's suction and discharge lines to determine the extent of contamination.
 - B. If contamination is noted for a considerable depth, consider replacing the lines with new tubing.
 - C. Confirm that the new compressor has no shipping damage. The line connections must come sealed from the factory. Verify that the replacement compressor is the same model number and electrical characteristics as the original.
 - D. Place the new compressor in the unit and install the mounting bolts.
 - E. Remove the caps from the compressor stubs, clean the lines and stubs, and braze joints together.
 - F. If any burn detected replace the liquid line filter drier with an oversized core filter drier, if the burn was severe, and a suction line filter drier.

Warnings:

1. **TACK APPROPRIATE STEPS TO KEEP CONTAMINATIONS OUT OF THE LINES, WHILE THESE LINE ARE OPEN TO ATMOSPHERE.**
2. **USE A OFMINIMUM 5% SILVER FOR COPPER TO COPPER CONNECTIONS.
USE A OF MINIMUM 35% SILVER FOR COPPER TO STEEL CONNECTIONS.**
3. **WHEN BRAZING, PURGE DRY NITROGEN THROUGH THE LINES TO PREVENT THE FORMATION OF OXIDES.**
- G. Inspect all other components such as check valve and electrical components for proper operation. Replace any if necessary.
- H. After all connections are made, open the service valves and pressurize to 150 psi with dry nitrogen, Leak test with liquid detergent. If a leak is found, repair it after removing the nitrogen ,and recheck.
- I. After leak testing ,recover any test refrigerant.
- J. Keep with (A) subpoints.
 - Evacuate through both high and low side connections to the system.
 - Evacuate to a level of 1500 microns twice and 500 microns the last time.
 - Break each vacuum with dry nitrogen to 3.0 psi.
 - Use the largest connections and hoses possible to expedite the process.
- K. Charge with clean, new or reclaimed R-22 refrigerant. Charge in accordance with proper charging procedures.
- L. Re-check the system 24 hours of run time to verify the unit is free of acid.

7. Other Check Points

- A. Verify the operating voltage is within the specified range.
- B. Check that all wiring connections are tight.
- C. Verify that all fuses or circuit breakers are of the proper type and operational.
- D. Verify the air conditioning operates properly in cooling.
- E. Inspect all the other electrical components for proper operation.
- F. Verify the thermostat and subbase are correct and operate properly.
- G. Verify all ducts and air moving device are sized and operate properly.
- H. Verify the refrigerant piping is sized correctly and not pinched.
- I. Verify all the system are in correct position.

10.2 Troubleshooting Guide

! WARNING – Disconnect all electrical power to the unit before servicing. Disconnect power to both the indoor and outdoor units. NOTE: There may be more than one electrical disconnect switch. Failure to shut off power can cause electrical shock resulting in personal injury or death.

Symptom	Possible Cause	Remedy
No cooling/heating	Power off or loose electrical connection	Make sure main switch is ON. Check and tighten all connections.
	Incorrect thermostat setting	Set thermostat correctly
	Defective 4-way valve	check the valve coil or replace it
	Compressor without pump function	replace it
Insufficient Cooling	Dirty filters	Clean & replace
	Indoor air blockage	Check supply registers and return grills for blockage.
	Blocked outdoor coil	Clear away leaves and other debris
	Improperly sized unit	Recalculate load
	Improper airflow	Check – should be 400CFM/Ton
	Incorrect refrigerant charge	Charge correctly per instruction.
	Air, non-condensable or moisture in system	Recover refrigerant, evacuate & recharge, add filter drier
Incorrect voltage	At compressor terminals, voltage must be within 10% of rating plate volts when unit is running.	
Water on floor or in furnace	Blocked condensate drain and “P” trap	Remove blockage and clean drain lines, verify operation of condensate pump.
Condenser fan and compressor don't run	AC Contact not connected to the power supply wire or not tightly fasten	Re-connect the power supply wire, and tightly fasten.
	The outdoor power supply main circuit switch in “OFF” position or fuse blown on main circuit	Reset the power supply switch to " ON" position or change the fuse and confirm the main power lead to the Contactor has voltage present.
	The coil of outdoor unit Contactor does not have 24V AC power	Check if the relay P2 of system PCB has a current output, if not, check if P1 and P3 have 24 V AC input. If have 24V AC , please check if it keep for 3 minutes, if so and P2 no output , change the 3-minute timer board; if keep time < 3 minutes , P2 no output ; if P1 、 P3 no24V AC, first check the thermostat C 、 Y terminal have 24 V AC, if no 24 V AC, then check the thermostat or reset the setting temp.; if have 24 V AC ,check if the C Y and P1、 P3 connection wire cut off or fasten loosely, if cut off , then change the parts.

Condenser fan runs, compressor doesn't	Run or start capacitor defective	Replace
	Loose connection	Check and tighten all connections.
	Compressor stuck, grounded or open motor winding, open internal overload	Wait for 2 hours for overload to reset. Replace compressor if still open.
	Low voltage condition	At compressor terminals, voltage must be within 10% of rating plate volts when unit is running.
Compressor runs, Condenser fan doesn't	Low voltage condition	Add start kit components
	Run capacitor defective	Replace
	Loose connection	Check and tighten all connections.
	Fan stuck, grounded or open motor winding, open internal overload	Wait for 2 hours for overload to reset. Replace Fan if still open.
	Low voltage condition	At compressor terminals, voltage must be within 10% of rating plate volts when unit is running.
	Defective overload protector	Replace – check for correct voltage
Register sweat	Refrigerant undercharge	Add refrigerant
	Low evaporator airflow	Increase blower speed or reduce restriction – replace air filter
High head – Low vapor pressures	Restriction in liquid line, metering device or filter drier	Replace defective components
	Flowrator piston size too small	Change to correct size piston
	Incorrect capillary tubes	Change coil assembly
High head – High or normal vapor pressures	Blocked outdoor coil	Clear away leaves and other debris
	Refrigerant overcharge	Correct system charge
	Condenser fan not running	Repair or replace
	Air, non-condensibles or moisture in system	Recover refrigerant, evacuate & recharge, add filter drier
Low head – High vapor pressures	Flowcheck piston size too large	Change to correct size piston
	Defective compressor valves	Replace compressor
	Incorrect capillary tubes	Replace coil assembly
Low vapor – cool compressor – iced evaporator coil	Low evaporator airflow	Increase blower speed or reduce restriction – replace air filter
	Operating below 65 °F outdoors	Add low ambient kit
	Moisture in the system	Recover refrigerant, evacuate & recharge, add filter drier
High vapor pressure	Excessive load	Recheck load calculation
	Defective compressor	Replace
Fluctuating head and vapor pressures	Air or non-condensibles in system	Recover refrigerant, evacuate & recharge.
Pulsing noise at metering device or liquid line	Air or non-condensibles in system	Recover refrigerant, evacuate & recharge

Electric control board and function for central air conditioner

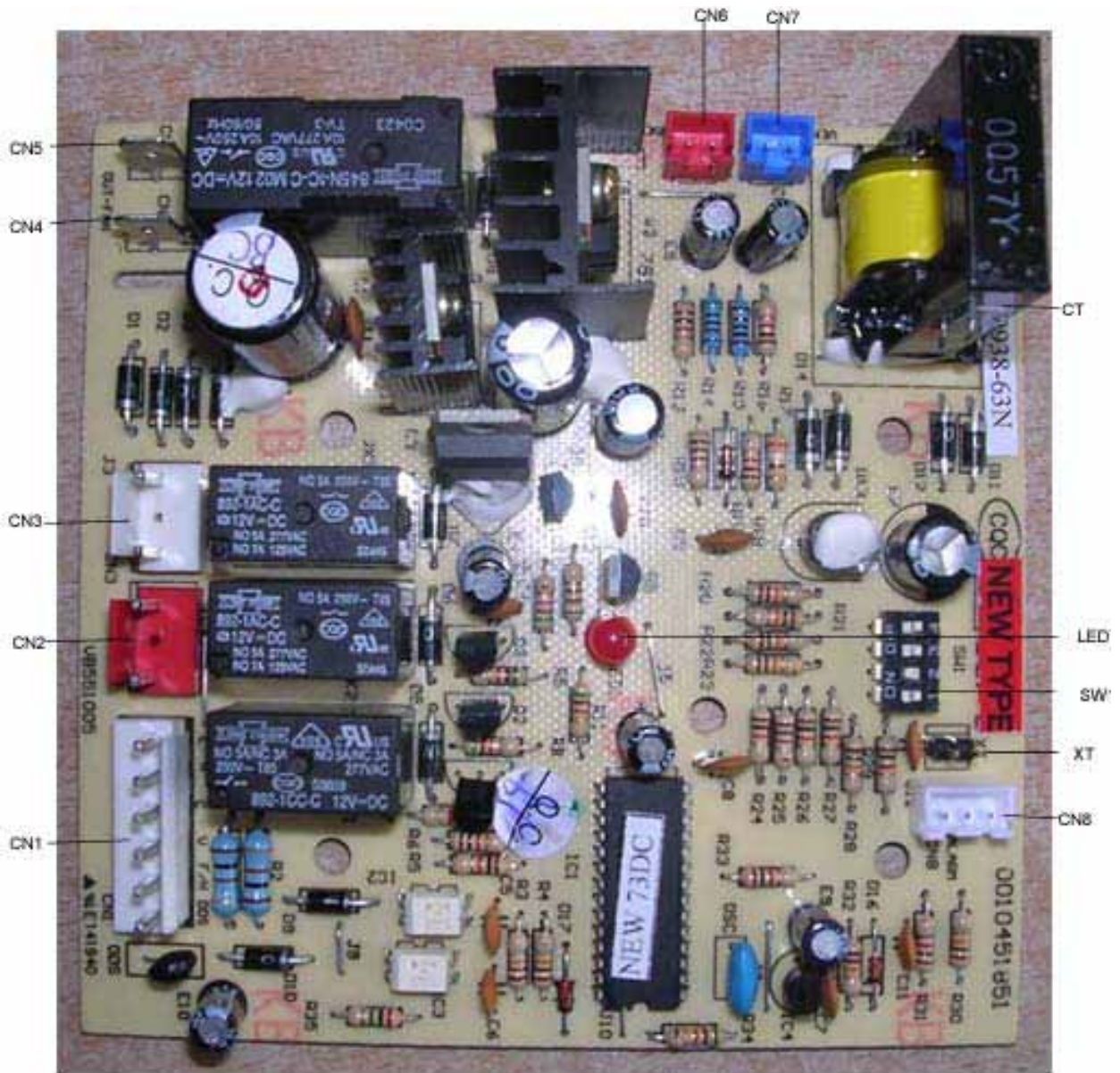

Heat pump control board

1. Failure code



Note: 1/2 second flash cycle indicates problem indication.

Failure indication: LED will flash for alarm. Flash frequency: 0.5 second on and 0.5 second off with a 2 seconds interval between flashes.

- 1.1 Outdoor coil temp. sensor failure: flash once
- 1.2 Compressor discharging temp. sensor failure: flash twice
- 1.3 Pressure switch failure: three times
- 1.4 Over current protection: four times

Indicator function:

When LED is used as failure indication, refer to the failure code.

When LED is used as a status indicator, the following codes will be shown:

1.5 In defrost, the LED will flash 2 seconds on, 2 seconds off.

1.6 In the normal operation state and the compressor is running – outdoor PCB LED will be in the ON state.

1.7 In normal state, if compressor not running – outdoor PCB LED will be OFF.

2. Function selection



Function selection for SW1:

2.1 SW1-1: ON-quick defrosting mode, used for very cold area, please see 5.2

OFF-default setting, normal defrost program, please see 5.1

2.2 SW1-2: ON-temperature point from which begin to count for defrost $T_p < 32^\circ\text{F}$

OFF- temperature point from which begin to count for defrost $T_p < 35.6^\circ\text{F}$

The setting for SW1-1, SW1-2 when out of factory: OFF, OFF.

2.3 Combinatoin of SW1-3, SW1-4:

OFF-OFF: current protection value 1

OFF-ON: current protection value 2

ON- OFF: current protection value 3

ON-ON: current protection value 4

The above current values are set when the equipment is shipped from factory, and they will be different values for different models. For the relationship between the dip switch setting and the compressor winding circles across CT, please refers to the wiring diagram with the unit.

3. Parameters value of temp. sensors

3.1 Outdoor coil temp. sensor: R25=5K Ω , B25/50=3450K, with copper terminal

T($^\circ\text{F}$)	Rnom(K Ω)	T($^\circ\text{F}$)	Rnom(K Ω)	T($^\circ\text{F}$)	Rnom(K Ω)	T($^\circ\text{F}$)	Rnom(K Ω)	T($^\circ\text{F}$)	Rnom(K Ω)
-4	47.12	28.4	19.39	60.8	7.661	93.2	3.368	125.6	1.667
-2.2	45.17	30.2	18.39	62.6	7.295	95	3.23	127.4	1.608
-0.4	43.24	32	17.45	64.4	6.949	96.8	3.098	129.2	1.551
1.4	41.35	33.8	16.55	66.2	6.622	98.6	2.973	131	1.457
3.2	39.49	35.6	15.7	68	6.313	100.4	2.845	132.8	1.445
5	37.68	37.4	14.89	69.8	6.021	102.2	2.741	134.6	1.395
6.8	35.92	39.2	14.13	71.6	5.744	104	2.633	136.4	1.347
8.6	34.21	41	13.41	73.4	5.482	105.8	2.536	138.2	1.301
10.4	32.56	42.8	12.73	75.2	5.235	107.6	2.432	140	1.257
12.2	30.37	44.6	12.08	77	5	109.4	2.339		
14	29.44	46.4	11.47	78.8	4.778	111.2	2.25		
15.8	27.57	48.2	10.9	80.6	4.567	113	2.165		
17.6	26.57	50	10.35	82.4	4.36	114.8	2.084		
19.4	25.22	51.8	9.837	84.2	4.179	116.6	2.006		
21.2	23.94	53.6	9.351	86	3.993	118.4	1.932		
23	22.72	55.4	8.892	87.8	3.819	120.2	1.862		
24.8	21.55	57.2	8.458	89.6	3.657	122	1.793		
26.6	20.45	59	8.048	91.4	3.514	123.8	1.729		

- 3.2 Outdoor discharging temp. sensor: $R_{80}=50K \pm 3\%$, $B_{25/80}=4450K \pm 3\%$, with copper terminal
- 3.3 High pressure switch: N.C. type pressure switch, the open pressure: 435Psi / close pressure: 377Psi; (adjustable)
- 3.4 Low pressure switch: N.C. type pressure switch, the open pressure: 7.25Psi / close pressure: 21.75Psi; (adjustable)
- 3.5 Signal continuous detecting time:

Pressure switch	30seconds	
Sensor value	20seconds	
Sensor failure (short circuit/open circuit)		2minutes

4. PCB port function

4.1 CN1—1,2,3,4 are corresponding to the input signal of R,C,Y,O. R: live line, 24VAC; C: neutral line, 0VAC; Y: 24V compressor input signal; O: 24V 4-way valve input signal. 5 is electric heating output signal, and used as 24V signal output to start up the electric heating function when defrosting. 6: pre-set.



See the figure, from left to right, they are 1,2,3,4,5,6.

4.2 CN2—24VAC control signal + 0VAC neutral line output; to control AC contactor winding.



4.3 CN3—24VAC control signal + 0VAC neutral line output; to control 4-way valve winding.



4.4 CN4, CN5—fan motor control port to control the neutral line of outdoor motor.



4.5 CN6—outdoor coil temp. sensor connector; the coil temp. sensor connected /disconnected failure: 30seconds later alarm; the failure can be resumable.

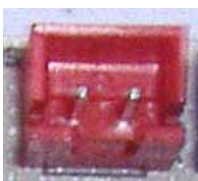

4.6 CN7 — — discharging temp. sensor connector; the discharging temp. sensor connected /disconnected failure: 30seconds later alarm; the failure can be resumable. When compressor is running, if the discharging temp. $>248^{\circ}\text{F}$, compressor will stop; if the discharging temp. $<203^{\circ}\text{F}$ for 3 minutes, compressor will run.



4.7 XT——time shorted function; twin-core pin; if it is with a jumper after being electrified, the PCB MCU time will be shorted;



4.8 CN8——pressure control port, can collect the signal.

If the pressure switch acts before the units start, the system will alarm immediately.

If the pressure switch hasn't acts before the units start, the system will alarm only when the switch acts 3 times within 30 minutes, the failure can not be resumable. Please reset the power to clear the alarm



4.9 CT——current value detected by current mutual inductor: after compressor is running, the running current will be detected, if it is over current protection value (depended by the dip switch setting) for continuous 20s, the unit will stop; 3 minutes later, it will resume to work. If it alarms for 3 times within 30 minutes, the failure can not be resumable. Please reset the power to clear the alarm



5. Defrosting operation (The unit of temp. is °F)

5.1 Defrosting procedure: SW1-1: OFF; SW1-2: OFF

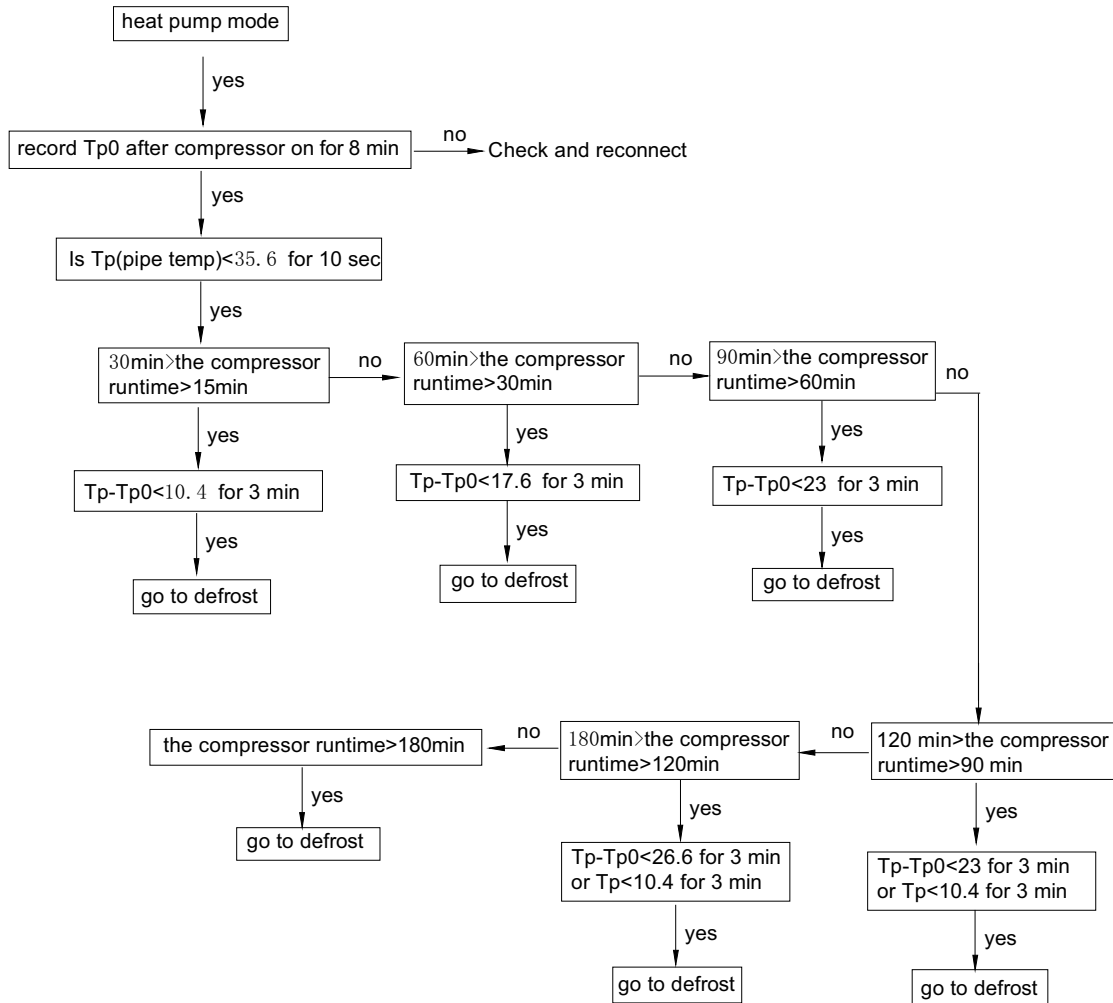

5.2 Defrosting procedure: SW1-1: ON; SW1-2: OFF

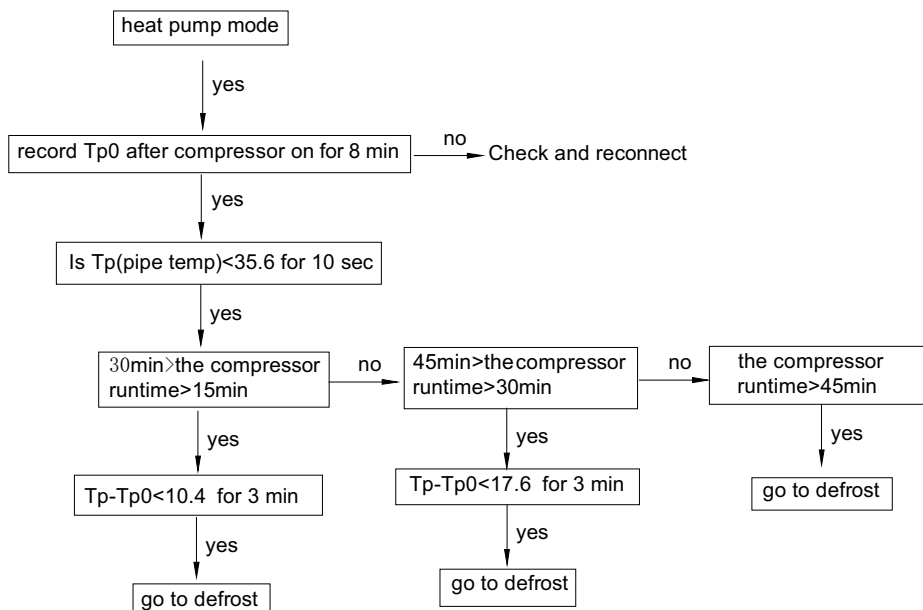

Note: The defrost action will be end when defrost has worked for 10 minutes or when the piping temp. arrives at or more than 50 °F.

5.3 Troubleshooting:

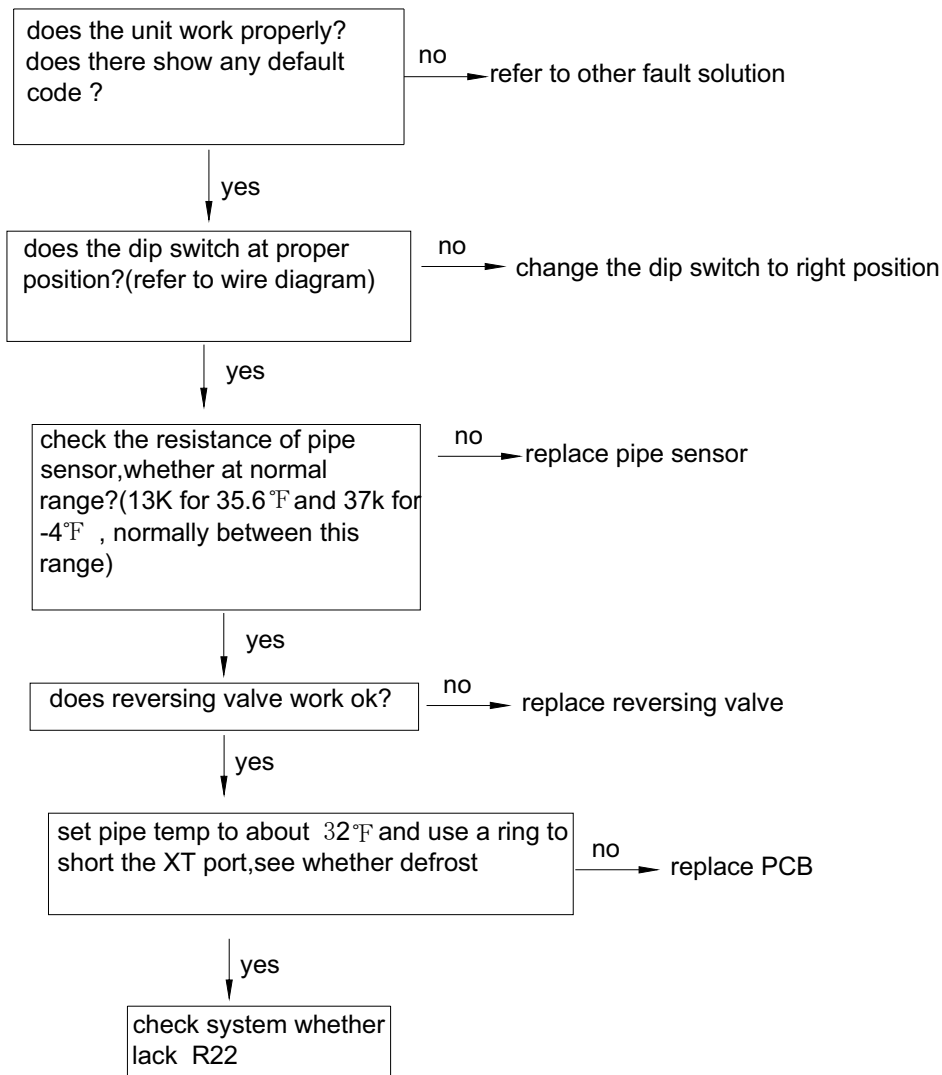

11. WIRING DIAGRAM

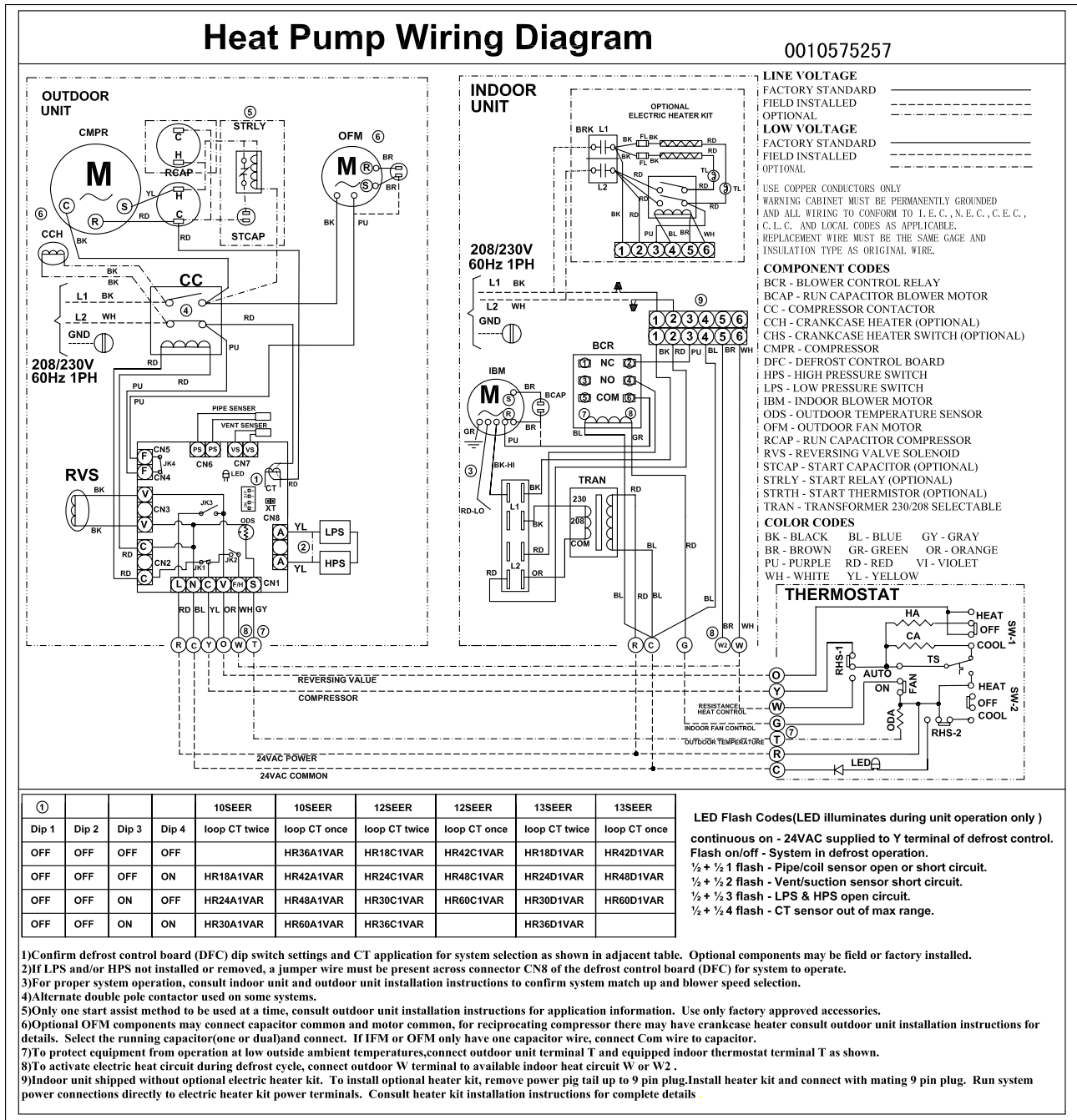

Note: The diagram wiring of the fan motor maybe have some difference from the real parts due to different types of fan motor, the detailed information can refer to the fan motor nameplate.
Outdoor Wiring Diagram (HR18D1VAR—HR60D1VAR)

Sincere Forever

Haier Group

Haier Industrial Park, No.1, Haier Road

266101, Qingdao, China

<http://www.haier.com>