

Frigidaire

Factory Parts Catalog

Product No.	BLTF2940FS0
Series	Frig/Brault
Market	Canada
Color	white
Volts	115
Wiring Diagram	134879500
Owner's Guide	134849000
Energy Guide	134816600
Installation Instructions	134848900
Operating Instructions	134848800



Electrolux Major Appliances
North & Latin America
5855 TERRY FOX WAY
MISSISSAUGA, ONTARIO, CANADA L5V
3E4

Publication No.
5995486759
07/03/20
(EN/SERVICE/BJH)
361

**FRONT-LOAD
WASHING MACHINE**

Model No.
BLTF2940F

Copyright © 2007 Electrolux Home Products, Inc.
All rights reserved.

CONTROL PANEL

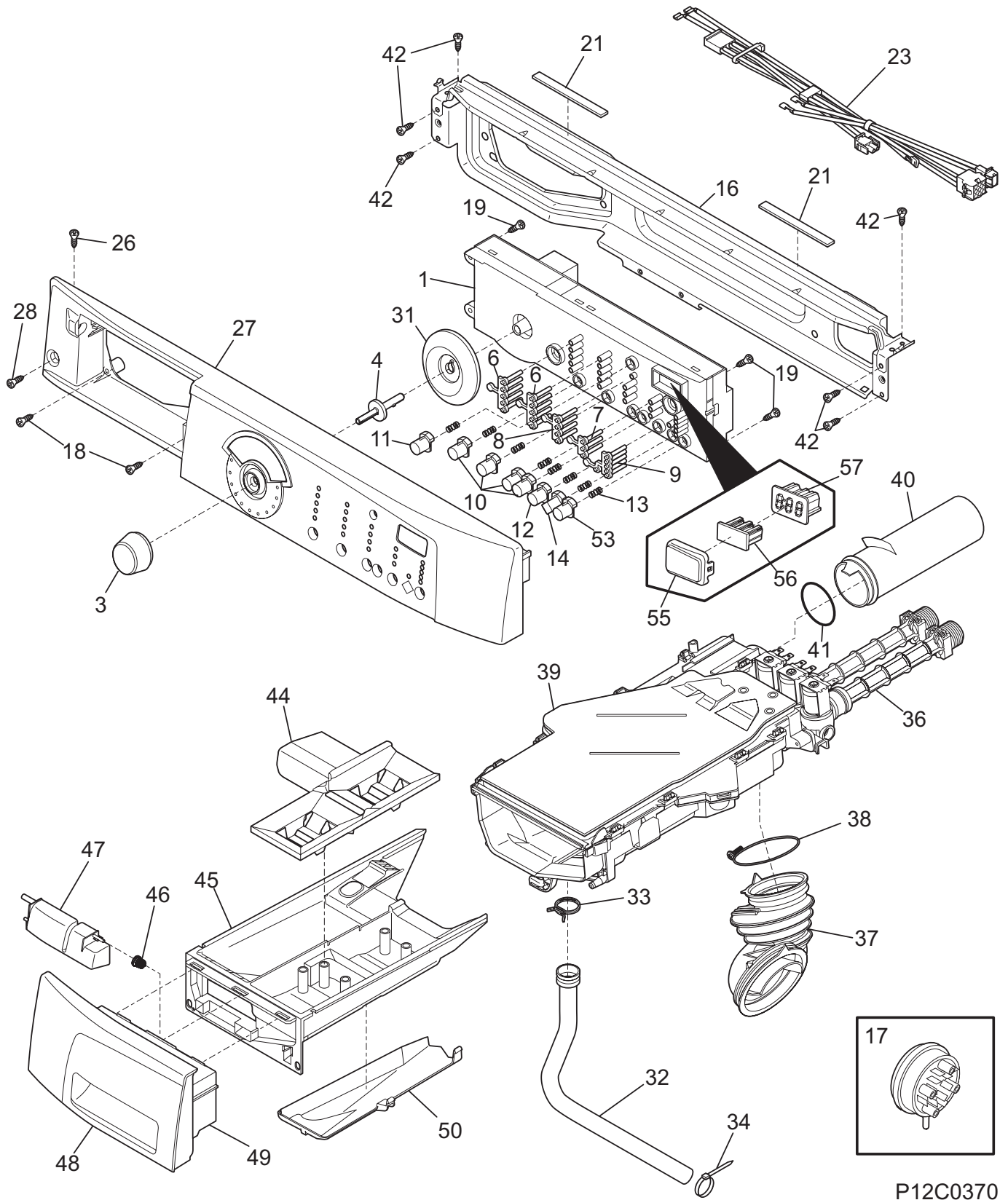

CONTROL PANEL

POS. NO	PART NO.	DESCRIPTION
1 #	134855503	Control Board, pc, with housing
3	134471500	Knob, program
4	134347700	Pin, program knob
6	134429100	Light Pipe, array, 1 row of 5
7	134429300	Light Pipe, array, 3 row of 3
8	134429200	Light Pipe, array, 2 row of 4
9	134429400	Light Pipe, array, 4 start group
10	134447160	Push Button, #1
11	134447560	Push Button, #5
12	134447460	Push Button, #4
13	134349400	Spring, push button
14	134447201	Push Button, #2
16	134364800	Bracket, top front
17 #	134407800	Switch, pressure, analog
18	131302800	Screw, 10-16AB x 0.375
19	134402900	Screw, phillips, 6-19 x 0.650
21	134407900	Dampener, vibration
23 #	134436600	Wiring Harness, controls
23*#	134743400	Wiring Harness, main
26	131205100	Screw, #8 pan head, 10-10B x 0.500, cr/sq drive
27	134543600	Panel, control console
28	131205300	Screw, 10-16 x 0.750
31	134761400	Bezel, knob flange
32	134586500	Hose, disp-to-bellows
33	131306216	Clamp
34	5303321209	Cable Tie, 5.60 inch
36 #	134371220	Valve, dispenser, NTC/short tube
36*	131311900	Screw, quadrex ph, 8-18AB x 0.500
37	134372300	Hose, disp-to-tub
38	134372400	Clamp, tub hose
39	134446120	Housing, dispenser, w/valve, cover
39*	134371300	Gasket, disp-to-valve
40	134372100	Tube, disp-to-overflo
41	134372200	O-ring, overflow tube
42	131168200	Screw, pan head, 8-18B x 0.31
44	134370200	Cover, dispenser
45	134370000	Drawer, dispenser
46	134349500	Spring, door latch
47	134386560	Latch, dispenser, black, lock
48	134798060	Handle, dispenser, front
49	134386260	Frame, drawer handle, black
50	134370100	Conveyor, dispenser, lower
53	134447301	Push Button, #3
55	134428900	Lens, digital display
56	134503400	Light Pipe, digital display
57 #	134503300	Display, digital

CABINET/TOP

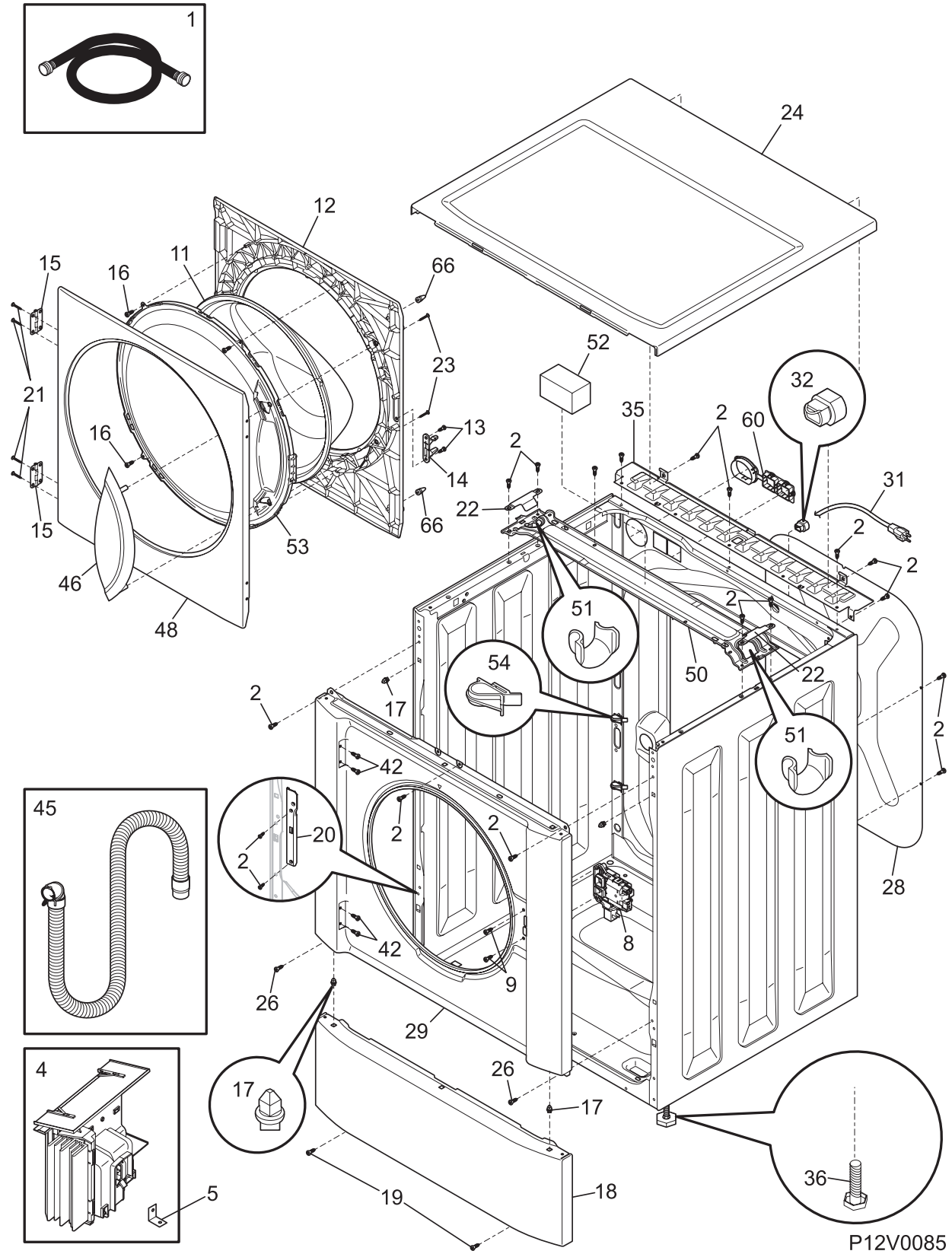

P12V0085

CABINET/TOP

POS. NO	PART NO.	DESCRIPTION
1	131454100	Hose, water inlet, 4 ft., hose & washer
2	131168200	Screw, pan head, 8-18B x 0.31
4 #	134409904	Control Board, motor
4* #	134547600	Wiring Harness, motor control
5	134522900	Bracket, angle, motor control
8 #	131763245	Door Lock/Switch Assy
8* #	134606800	Wiring Harness, door switch
9	131303300	Screw, pan head, 10-16AB x 0.500, locking
11	134366400	Panel, door glass
12	134507300	Panel, inner door, with bumper
13	131302901	Screw, 10-16 x 0.750
14	131763310	Striker, door/lock/sw
15	134412400	Hinge, door
16	134178901	Screw, 8-18AB x 0.455
17	134408700	Clip, assembly
18	134321702	Panel, front service, white
19	131258400	Screw, 10-16AB x 0.500
20	134434901	Bracket, LS panel, reinforcement
20*	134434900	Bracket, RS panel, reinforcement
21	134424700	Screw, comb flat head, 8-18AB x 0.75
22	134364700	Retainer, spring steel
23	134522100	Screw, #12 flat head, 10-14P, quad drive
24	134365000	Panel, work top, white
26	134521600	Screw, hex washer head, M5 0.8 x 15
28	134364300	Panel, service access, rear
29	134363300	Panel, cabinet front, white
31 #	134501000	Power Cord, electric svce
32	5303209428	Bushing, power cord
35	134365100	Bracket, top support, rear
36	134548800	Leveling Leg, screw, plastic
42	134156200	Screw, flat head, 8-18AB x 0.44, quad drive
45 #	134369400	Hose, drain, external
46	134472203	Handle, door
48	134412103	Panel, outer door, white
50	134364600	Bracket, tub suspension
51	134562100	Protector, tub brkt, spring hook, (2)
52	131931202	Dampener, vibration, foam
53	134507404	Adapter, door glass ring
54	134364900	Fastener, wire harn clip
60	134372000	Grommet, dispenser, back panel
66	134366500	Bumper, door
*	134591500	Plug Assy, shipping holes, back
*	134596200	Shipping Support Kit

MOTOR/TUB

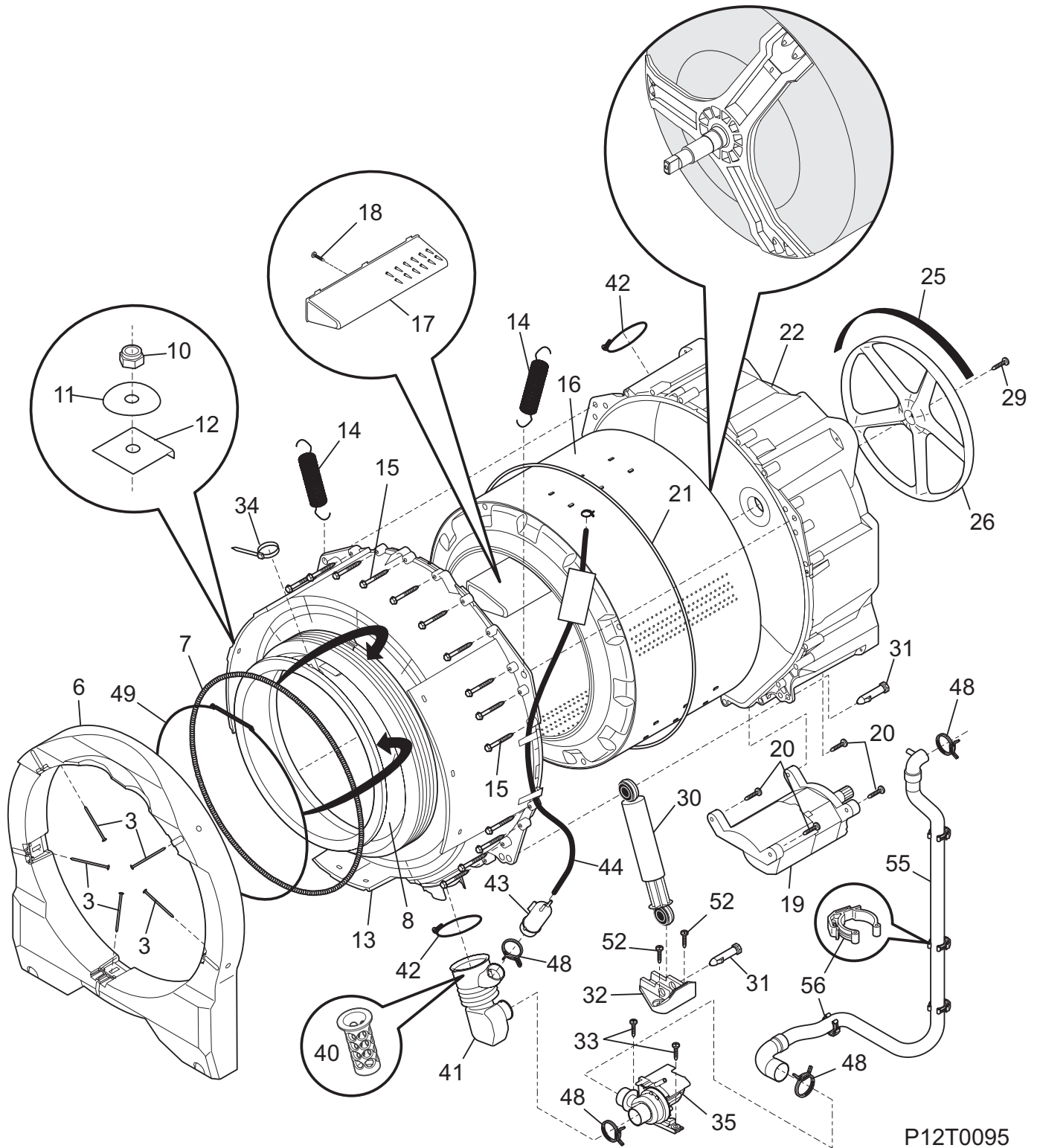

P12T0095

MOTOR/TUB

POS. NO	PART NO.	DESCRIPTION
3	131793303	Bolt, carriage, 1/4-20 x 2.60
6	134362200	Counterweight, front, one piece
7	134365300	Spring, bellows clamp, retainer
8 #	134515300	Bellows Kit, boot, no light hole
10	131304700	Nut, hex, 1/4-20 UNC-2B, (2)
11	131276900	Washer, Bellville, spring steel
12	134430600	Plate, counterweight
13	134362000	Shell, tub, front
14 #	134362800	Spring Assy, suspension
15	134408300	Screw, hex head, 6.5 x 51 mm
16	134360910	Drum Assy, spin basket
17	134509600	Vane Kit, drum
18	131302800	Screw, 10-16AB x 0.375
19 #	134362500	Motor, 120 V
20	131303500	Screw, 12-14AB x 1.50, motor mtg.
21	134361900	O-ring, tub
22	134509510	Shell, outer tub, rear, w/bearing, seal
25 #	134051001	Belt, drive, poly-V, 6-rib
26 #	134362600	Pulley, drum drive, large, rear
29	134408400	Screw, 10.9 class, M10 x 25 mm
30	134560400	Shock Absorber, dual stage
31	131268300	Pin, shock mtg.
32	134363200	Bracket, shock mtg.
33	134160900	Screw, washer hd, 10-16AB X 0.75
34	5303321209	Cable Tie, 5.60 inch
35 #	134051200	Pump, drain
40	134565200	Filter, pump
41	134455900	Hose, coin trap, tub-to-pump
42	134737300	Clamp, hose
43	134369000	Chamber, air
44	134369900	Hose, air pressure
48	131306234	Clamp, hose, wire
49	134527100	Clamp, bellows, spring held
52	131202300	Screw, 10-16AB x 0.625
55 #	134679000	Hose, internal drain
56	134369800	Fastener, hose clip, (3)
56*	134261300	Clip, drain hose, push-mount
*	134816600	Energy Guide

WIRING DIAGRAM

WARNING TO REDUCE THE RISK OF ELECTRICAL SHOCK DISCONNECT THIS APPLIANCE FROM THE POWER SUPPLY BEFORE ATTEMPTING ANY USER MAINTENANCE. TURNING THE CONTROLS TO THE OFF POSITION DOES NOT DISCONNECT THIS APPLIANCE FROM THE POWER SUPPLY.

AVERTISSEMENT POUR RÉDUIRE LE RISQUE DE CHOC ÉLECTRIQUE, DÉBRANCHER CET APPAREIL DE L'ALIMENTATION AVANT DE PROCÉDER À L'ENTRETIEN. EN TOURNANT LES COMMANDES À LA POSITION ARRÊT, L'ON NE COUPE PAS L'ALIMENTATION ÉLECTRIQUE DE L'APPAREIL.

ADVERTENCIA PARA REDUCIR EL RIESGO DE CHOQUE ELÉCTRICO, DESENCHUFE ESTE APARATO DE LA ALIMENTACIÓN ELÉCTRICA ANTES DE EFECTUAR EL MANTENIMIENTO. AL GIRAR LOS CONTROLES A LA POSICIÓN OFF (APAGADO) NO SE CORTA LA ALIMENTACIÓN ELÉCTRICA AL ARTEFACTO.

COMPONENT RESISTANCE TABLE

ELECTRICAL COMPONENT	RESISTANCE Ω @ 77°	
DOOR LOCK SOLENOID	1325 ±10%	
PUMP MOTOR	12.0 ±7%	
DISPENSER VALVE SOLENOIDS	800 ±7%	
MOTOR	M1 TO M2	5.3 ±7%
	M2 TO M3	5.3 ±7%
	M1 TO M3	5.3 ±7%
	M5 TO M4	118 ±7%

TABLEAU DE RÉSISTANCE DES COMPOSANTS

COMPOSANT ÉLECTRIQUE	RÉSISTANCE Ω @ 25°C	
SOLENOÏDE DU LOQUET DE PORTE	1325 ±10%	
MOTEUR DE POMPE	12.0 ±7%	
SOLENOÏDE DU ROBINET DISTRIBUTEUR	800 ±7%	
MOTEUR	M1 VERS M2	5.3 ±7%
	M2 VERS M3	5.3 ±7%
	M1 VERS M3	5.3 ±7%
	M5 VERS M4	118 ±7%

TABLA DE RESISTENCIA DE LOS COMPONENTES

COMPONENTE ELÉCTRICO	RESISTENCIA Ω @ 25°C	
SOLENOIDE DE CIERRE DE LA PUERTA	1325 ±10%	
BOMBA DE MOTOR	12.0 ±7%	
SOLENOIDE DE LA VALVULA DEL DISTRIBUIDOR	800 ±7%	
MOTOR	M1 A M2	5.3 ±7%
	M2 A M3	5.3 ±7%
	M1 A M3	5.3 ±7%
	M5 A M4	118 ±7%

SELECT MODELS\MODELS DE SELECTEUR\MODELOS DE SELECTOR

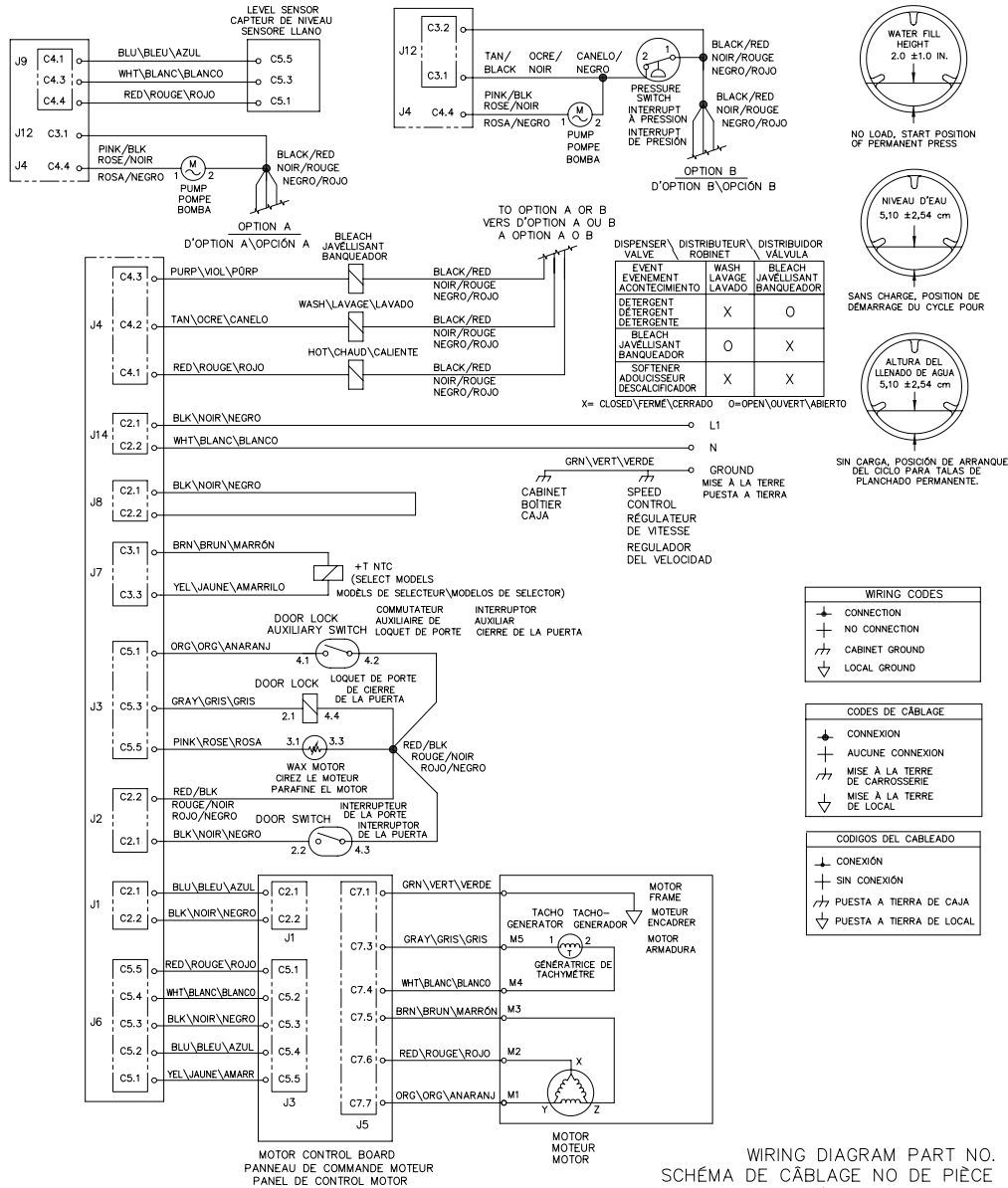

WIRING DIAGRAM PART NO. SCHEMA DE CÂBLAGE NO DE PIÈCE DIAGRAMA DE CONEXIONES NO DE PIEZA 134879500 A