

Masterbuilt Manufacturing, Inc
 1 Masterbuilt Court
 Columbus, Georgia 31907
 Customer Service 1-800-489-1581

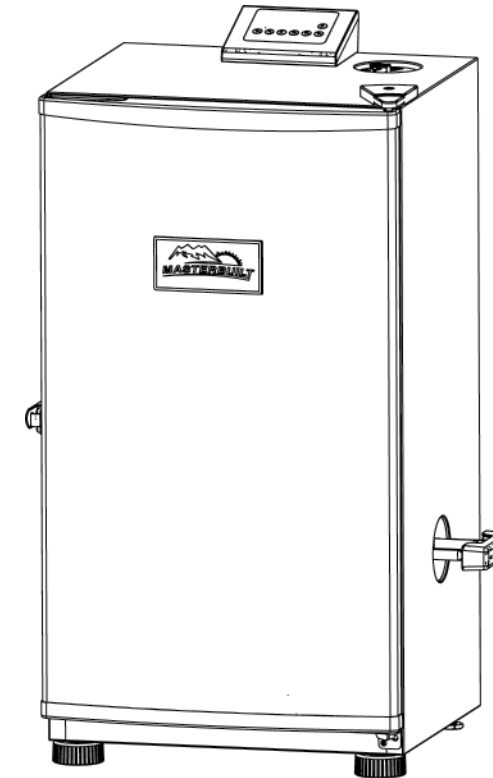





**ASSEMBLY, CARE & USE MANUAL
 WARNING & SAFETY INFORMATION
 MODEL 20070814 DIGITAL SMOKEHOUSE
 THIS PRODUCT IS FOR OUTDOOR USE ONLY ~ HOUSEHOLD TYPE**



Manual Code: 9807120050 062712-04SS

Approximate assembly time : 10 minutes.

Tools required for assembly: Phillips Head Screwdriver.

 CARBON MONOXIDE HAZARD 	 WARNING 
<p>Burning wood gives off carbon monoxide which can cause death.</p> <p>DO NOT burn wood chips inside homes, vehicles, tents, garages or any enclosed areas.</p> <p>Use only outdoors where it is well ventilated.</p>	<p>This manual contains important information necessary for the proper and safe use of this unit.</p> <p>Read and follow all warnings and instructions before using smoker and during use.</p> <p>Keep this manual for future reference.</p> <p>Some parts may have sharp edges handle with care.</p>
<p>Failure to follow these warnings and instructions properly could result in personal injury or death.</p>	



WARNINGS & IMPORTANT SAFEGUARDS



READ ALL INSTRUCTIONS

When using electrical appliances, basic safety precautions should always be followed including the following:

- For outdoor use only. Do not operate in an enclosed area.
- Unit **MUST** be on the ground. Do not place unit on tables or counters.
- Do not plug in electric smoker until fully assembled and ready for use.
- Use only on properly grounded outlet.
- Do not use during an electrical storm.
- Do not expose electric smoker to rain or water at anytime.
- To protect against electrical shock do not immerse cord, plug or controller in water or other liquid.
- Do not operate any appliance with a damaged cord or plug, or after appliance malfunctions or is dropped or damaged in any manner. Contact Masterbuilt Customer Service for assistance at 1-800-489-1581.
- Keep a fire extinguisher accessible at all times while operating electric smoker.
- Do not let cord touch hot surfaces.
- Do not place on or near a hot gas or electric burner, or in a heated oven.
- Keep children and pets away from electric smoker at all times. Do not allow children to use electric smoker. Close supervision is necessary should children or pets be in area where electric smoker is being used.
- Fuel, such as charcoal briquettes or heat pellets, are not to be used in electric smoker.
- Never use electric smoker as a heater (READ CARBON MONOXIDE HAZARD).
- Use electric smoker only on a level, stable surface to prevent tipping.
- Electric smoker is hot while in use and after.
- Electric smoker is HOT while in use and will remain HOT for a period of time afterwards. Use caution.
- Do not touch HOT surfaces.
- Do not allow anyone to conduct activities around electric smoker during or following its use until the unit has cooled. Electric smoker is HOT during operation and remains HOT for a period of time following use.
- The use of alcohol, prescription or non-prescription drugs may impair the user's ability to properly assemble or safely operate electric smoker.

WARNINGS & IMPORTANT SAFEGUARDS CONTINUED ON PAGE 2

LIMITED WARRANTY INFORMATION

Masterbuilt warrants its products to be free from defects in material and workmanship under proper assembly, normal use and recommended care for 90 days from the date of original retail purchase.

Masterbuilt warranty does not cover paint finish as it may burn off during normal use.

Masterbuilt warranty does not cover rust of the unit.

Masterbuilt requires reasonable proof of purchase for warranty claims and suggests that you keep your receipt. Upon the expiration of such warranty, all such liability shall terminate.

Within the stated warranty period, Masterbuilt, at its discretion, shall repair or replace defective components free of charge with owner being responsible for shipping. Should Masterbuilt require return of component(s) in question for inspection Masterbuilt will be responsible for shipping charges to return requested item.

This warranty excludes property damage sustained due to misuse, abuse, accident, damage arising out of transportation, or damage incurred by commercial use of this product.

This expressed warranty is the sole warranty given by Masterbuilt and is in lieu of all other warranties, expressed or implied including implied warranty, merchantability, or fitness for a particular purpose.

Neither Masterbuilt nor the retail establishment selling this product, has authority to make any warranties or to promise remedies in addition to or inconsistent with those stated above.

Masterbuilt's maximum liability, in any event, shall not exceed the purchase price of the product paid by the original consumer/ purchaser. Some states do not allow the exclusion or limitation of incidental or consequential damages. In such a case, the above limitations or exclusions may not be applicable.

California residents only: Notwithstanding this limitation of warranty, the following specific restrictions apply; if service, repair, or replacement of the product is not commercially practical, the retailer selling the product or Masterbuilt will refund the purchase price paid for the product, less the amount directly attributable to use by the original buyer prior to the discovery of the nonconformity. Owner may take the product to the retail establishment selling this product in order to obtain performance under warranty.

This expressed warranty gives you specific legal rights, and you may also have other rights which vary from state to state.

Go Online www.masterbuilt.com

or complete and return to

Attn: Warranty Registration

Masterbuilt Mfg. Inc.

1 Masterbuilt Court - Columbus, GA 31907

Name: _____

Address: _____

City, State/Province, Postal Code: _____

Phone Number: _____ E-Mail Address: _____

Model Number: _____ Serial Number: _____

Purchase Date: _____ Place of Purchase: _____

MASTERBUILT SMOKIN' RECIPES continued

SMOKED HAMBURGER JERKY

INGREDIENTS:
 Ground beef (lean) 2 lbs (0.91 kg)
 Ginger (grated) 2 tsp

 Allspice 1 tbs
 Sugar 4 tbs
 Garlic (minced) 1 clove
 Soy sauce ½ cup

SUGGESTED WOOD FOR SMOKING:
 Hickory or Mesquite chips

INSTRUCTIONS:

Press hamburger meat into flat strips 5" (13cm) long by 1 ½" (4cm) wide and ¼" (6mm) thick. Place one layer of hamburger strips in dish for marinating. Combine all marinade ingredients in a small bowl until blended well. Sprinkle marinade over meat, soaking well. Turn meat over and again sprinkle with marinade. Add layers of hamburger strips to marinating dish and repeat sprinkling process until both are used. Cover tightly and let marinate in refrigerator for 6 to 10 hours. Rotate meat layers occasionally during this time. Place in smoker at 140°F (60°C). Cook for 4 hours.

SMOKED PORK BUTT

Servings for 6

INGREDIENTS:
 Fresh Pork Butt 7 lbs (3.1kgs)
 Salt ½ tsp
 Brown sugar ¼ cup
 Chili Powder 2 tbs

SUGGESTED WOOD FOR SMOKING:
 Apple chips

INSTRUCTIONS:

Mix ingredients and rub onto pork butt. Cook pork butt for 5 hours in 225°F (107°C) smoker using apple wood chips during first 3 hours. After 5 hours remove butt and wrap in heavy foil. Cook for an additional 1 to 1 ½ hours. Internal temperature should be 160°F (71°C). Serve.

VENISON JERKY

INGREDIENTS:
 Venison 2 lbs (0.91kg)
 Brown sugar ½ cup
 Worcestershire ½ cup

 Garlic salt ½ tsp
 Soy sauce ½ cup
 Dry mustard ½ tsp
 Salt ¼ cup
 Pepper dash
 Water 3 cups

SUGGESTED WOOD FOR SMOKING:
 Hickory or Mesquite chips

INSTRUCTIONS:

Cut meat into ¼" to ½" (6-13mm) thick strips about 5" (13cm) long and 1 ½" wide (4cm). Combine all marinade ingredients in a small bowl until blended well. Marinate meat for 6 to 8 hours. Dry and place in smoker at 140°F (60°C). Smoke for 12 to 16 hours.

SMOKED SAUSAGE

INGREDIENTS:
 Fresh Pork or Beef sausage
 Seasonings to taste

SUGGESTED WOOD FOR SMOKING:
 Hickory or Mesquite chips

INSTRUCTIONS:

Place sausage in smoker at 150°F (65.5°C). Smoke for 5 to 6 hours or until outside casings begin to dry and change to a red color.

WOOD SMOKING GUIDE FOR MEATS

WOOD FLAVOR	POULTRY	FISH	HAM	BEEF	PORK	LAMB
Hickory Pungent, smoky, bacon-like flavor	✓	✓	✓	✓	✓	
Mesquite Sweet and delicate flavor	✓			✓		✓
Alder Delicate, wood smoke flavor	✓	✓			✓	
Pecan Bold and hearty flavor	✓	✓			✓	
Maple Sweet, subtle flavor	✓				✓	
Apple Sweet, delicate flavor	✓	✓			✓	
Cherry Sweet, delicate flavor	✓				✓	



WARNINGS & IMPORTANT SAFEGUARDS continued



- Avoid bumping or impacting electric smoker.
- Never move electric smoker when in use. Allow electric smoker to cool completely before moving or storing.
- Be careful when removing food from electric smoker. All surfaces are HOT and may cause burns. Use protective gloves or long, sturdy cooking tools.
- Do not cover cooking racks with metal foil. This will trap heat and cause severe damage to electric smoker.
- Drip tray is only for the bottom of electric smoker. Do not put drip tray on cooking racks this may damage electric smoker.
- Wood chip bowl is HOT when electric smoker is in use. Use caution when adding wood.
- To disconnect, turn controller "OFF" then remove plug from outlet.
- Remove plug from outlet when the appliance is not in use, before putting on or taking off parts, and before cleaning. Allow to cool before handling.
- Dispose of cold ashes by placing them in aluminum foil, soaking with water and discarding in a non-combustible container.
- Do not store electric smoker with HOT ashes inside unit. Store only when all surfaces are cold.
- Accessory attachments not supplied by Masterbuilt Manufacturing, Inc. are not recommended and may cause injury.
- Never use electric smoker for anything other than its intended purpose. This unit is not for commercial use.
- Always use electric smoker in accordance with all applicable local, state and federal fire codes.
- Longer extension cords are available and may be used if care is exercised in their use.
- If a longer extension cord is used the marked rating should be at least as great as the electrical rating of the appliance.
- The extension cord must be a grounding -type 3-wire cord.
- Outdoor extension cords must be used with outdoor use products and are marked with suffix "W" and with the statement "Suitable for Use with Outdoor Appliances."
- CAUTION - To reduce the risk of electric shock, keep extension cord connection dry and off the ground.
- Extreme caution must be used when moving an appliance containing hot liquids.
- Do not clean this product with a water spray or the like.

SAVE THESE INSTRUCTIONS.



WARNING



Combustion by-product produced when using this product contains chemicals known to the State of California to cause birth defects, other reproductive harm, or cancer.

The materials used in this product may contain lead a chemical known to the State of California to cause birth defects and other reproductive harm.

LET'S GET STARTED!

- This is a slow smoker...allow sufficient time for cooking. Smoker is for OUTDOOR USE ONLY.
- "Preseason" smoker prior to first use. See page 8.
- Pre-heat smoker for 30 to 45 minutes at max temperature before loading food.
- DO NOT cover racks with aluminum foil as this will not allow heat to circulate properly.
- Do not overload smoker with food. Extra large amounts of food may trap heat, extend cooking time and cause uneven cooking. Leave space between food on racks and smoker sides to ensure proper heat circulation. If utilizing cooking pans, place pans on center of rack to ensure even cooking. Please see manual for more detail.
- Close air damper on top of unit to retain moisture and heat. If cooking foods such as fish or jerky, open air damper to release moisture.
- Temperature reading on control panel will fluctuate + or - 10 to 15 degrees as smoker cycles on and off.
- Store smoker in a dry area after use.
- Extreme cold temperatures may extend cooking times.
- **CLEAN AFTER EVERY USE.** This will extend the life of your smoker and prevent mold and mildew.

ENJOY!

MASTERBUILT SMOKIN' RECIPES continued

SMOKED STUFFED SALMON

Servings for 4

INGREDIENTS:
 Salmon (drawn) 4 - 5 lbs (1.8-2.2 kgs)
 Oil 3 tbs
 Green onion (chopped) ¼ cup
 Tomato (peeled and chopped) 1 cup
 Dill (fresh and chopped) ¼ cup
 Bread cubes (dry) ½ cup
 Celery (chopped) ¼ cup
 Salt ¼ tsp
 Lemon pepper ½ tsp
 Garlic (minced) 1 clove

SUGGESTED WOOD FOR SMOKING:
 Hickory chips

INSTRUCTIONS:
 Prepare salmon and brush with oil. Combine remaining ingredients in a small bowl. Stuff salmon with mixture. Place salmon on a sheet of heavy aluminum foil that has been doubled and greased. Place in smoker at 225°F (107°C) and cook for 3 to 4 hours. Make sure there is room on either side of foil to allow airflow inside smoker.



SMOKED SUMMER VEGETABLES

Servings for 4-6

INGREDIENTS:
 Summer Squash
 Zucchini
 Onion
 Mushrooms
 French Cut Green Beans

SUGGESTED WOOD FOR SMOKING:
 Hickory or apple wood chips

INSTRUCTIONS:
 Rinse and thinly slice summer squash, zucchini and onion. Mix all vegetables together. Form cup shaped containers using heavy duty aluminum foil. Place about 1 cup of vegetable mix in each foil cup. Season to taste with your favorite herbs and spices. Pinch top of foil cups together. To allow smoke penetration put a couple of small holes around top of each vegetable cup. Place foil cups in smoker at 220°F (104°C) for 1 hour. Serve.

SMOKED TROUT

Servings for 6

INGREDIENTS:
 Trout fillets 4 - 6
 Water 2 cups
 Soy sauce ¼ cup
 Teriyaki sauce ¼ cup
 Salt ½ tsp
 Lemon pepper 1 tsp
 Garlic salt
 Dill seed

SUGGESTED WOOD FOR SMOKING:
 Hickory, alder or apple chips

INSTRUCTIONS:
 Mix recommended amounts of water, soy sauce, teriyaki sauce and salt with other ingredients to your liking in a small container. Place fillets into marinade, cover and let soak in refrigerator overnight. Smoke for 3 to 4 hours or until meat is flaky and dry in smoker at 225°F (107°C).

MAPLE GLAZED HAM

Servings for 6-8

INGREDIENTS:
 Ham shank or butt (fully cooked, bone-in) 5 - 7 lbs (2.2-3.1 kgs)
 Maple syrup 1 ½ cup
 Ginger 1 tsp
 Nutmeg ¼ tsp
 Allspice ½ tsp
 Cloves 16 whole
 Pineapple slices (canned) 1 can
 Maraschino Cherries 1 jar

SUGGESTED WOOD FOR SMOKING:
 Hickory or Mesquite chips

INSTRUCTIONS:
 Remove thick skin and trim fat leaving no more than 1/2" (13mm) thick covering on ham. Score ham. Combine syrup, ginger, nutmeg, and allspice in a small bowl. Place ham in a large dish and baste with syrup mixture. Let ham stand in syrup mixture for 1 to 2 hours basting frequently until ham at room temperature. When ready to smoke remove ham from dish and stud with cloves. Place ham in 225°F (107°C) smoker. Cook for 2 to 3 hours. Baste with syrup mixture at least two times during cooking time. Before last hour of smoking, decorate ham with canned pineapple and cherries and baste. Internal temperature of ham should be at 130°F to 140°F (54-60°C) when heated thru.

TO ENSURE THAT IT IS SAFE TO EAT, FOOD MUST BE COOKED TO THE MINIMUM INTERNAL TEMPERATURES LISTED IN THE TABLE BELOW.

USDA* Safe Minimum Internal Temperatures	
Fish	145°F (63°C)
Pork	160°F (71°C)
Egg Dishes	160°F (71°C)
Steaks and Roasts of Beef, Veal or Lamb	145°F (63°C)
Ground Beef, Veal or Lamb	160°F (71°C)
Whole Poultry (Turkey, Chicken, Duck, etc.)	165°F (74°C)
Ground or Pieces Poultry (Chicken Breast, etc.)	165°F (74°C)

* United States Department of Agriculture

IMPORTANT FACTS ABOUT USING SMOKER

- Maximum temperature setting is 275°F (135°C).
- Wood chip loader and wood chip holder **MUST** be in place when using smoker. This minimizes the chance of wood flare ups.
- Wood chips must be used in order to produce smoke and create the smoke flavor. See “Wood Smoking Guide for Meats” section in this manual.
- Check grease tray often during cooking. Empty grease tray when full. Grease tray may need to be emptied periodically during cooking.
- Do not open smoker door unless necessary. Opening smoker door causes heat to escape and may cause wood to flare up. Closing the door will re-stabilize the temperature and stop flare up.
- Do not leave old wood ashes in the wood tray. Once ashes are cold empty tray. Tray should be cleaned out prior to and after each use to prevent ash buildup.
- This is a smoker. There will be a lot of smoke produced when using wood chips. Smoke will escape through seams and turn the inside of smoker black. This is normal. To minimize smoke loss around door, door latch can be adjusted to further tighten door seal against body.

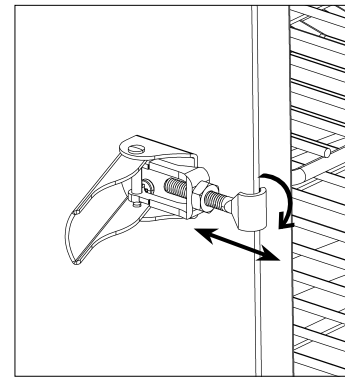

Loosen hex nut on door latch. Turn hook clockwise to tighten as shown. Secure hex nut firmly against door latch.

HOW TO CLEAN SMOKER

For cooking racks, water bowl and drip tray use a mild dish detergent. Rinse and dry thoroughly.

For wood chip holder and wood chip loader, clean frequently to remove ash build up, residue and dust.

For the interior and exterior of smoker simply wipe down with a damp cloth. Do not use a cleaning agent. Make sure to dry thoroughly.

Door seal and inside seam that seal attaches to **MUST** be cleaned after each use to keep seal in proper working condition.

ALWAYS MAKE SURE UNIT IS UNPLUGGED AND COOL TO THE TOUCH BEFORE CLEANING AND STORING.

PARTS LIST

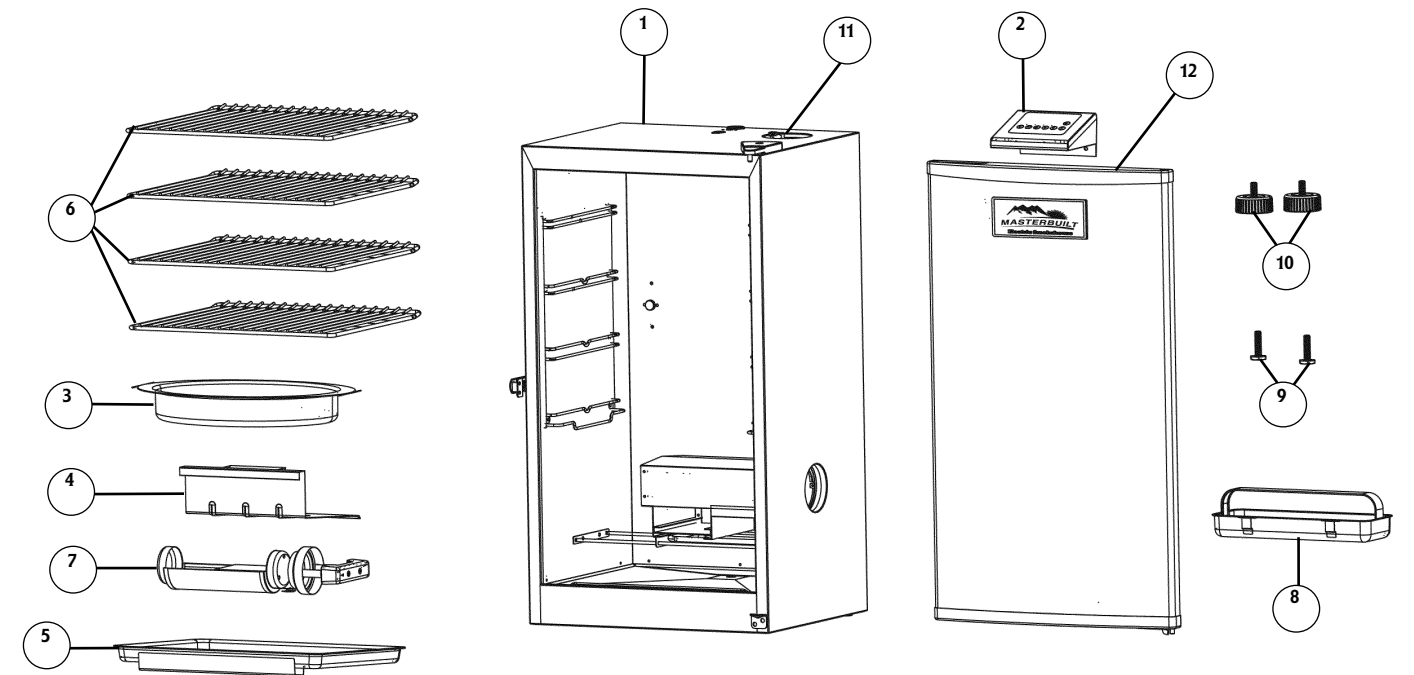

ITEM NO.	QUANTITY	DESCRIPTION	ITEM NO.	QUANTITY	DESCRIPTION
1	1	Smoker Body	7	1	Wood Chip Loader
2	1	Digital Control Panel	8	1	Grease Tray
3	1	Water Bowl	9	2	Adjustable Screw Leg (pre-assembled)
4	1	Wood Chip Holder	10	2	Leg Boot (pre-assembled)
5	1	Drip Pan	11	1	Air Damper (pre-assembled)
6	4	Cooking Rack	12	1	Door (pre-assembled)

PARTS LIST

ITEM NO.	DESCRIPTION	ITEM NO.	DESCRIPTION
9907090049	Door (Black)	910050029	Cooking Rack
990050048	Digital Control Panel Kit	910050030	Water Bowl
990050049	Cooking Rack Support Rack Kit	9007090093	Wood Chip Loader
990070024	Wood Chip Holder Kit	910070028	Drip Pan
9007090092	Wood Chip Holder	910060047	Grease Tray
9907090033	Element Kit	9900500024	Grease Tray Bracket Kit
9907090047	Body Kit (Black)	910050006	Adjustable Screw Leg
990060221	Air Damper Kit	910050009	Leg Boot
990050222	Door Latch Kit (Black)	9807120050	Instruction Manual
9907090041	Door Hinge Kit (Black)	998050010	Hardware Kit
		9007120057	Cover

STOP!

DO NOT RETURN TO RETAILER
For Assembly Assistance, Missing or Damaged Parts
Call: MASTERBUILT Customer Service at 1-800-489-1581.

ASSEMBLY INSTRUCTIONS

Tools required for assembly: Phillips Head Screwdriver.

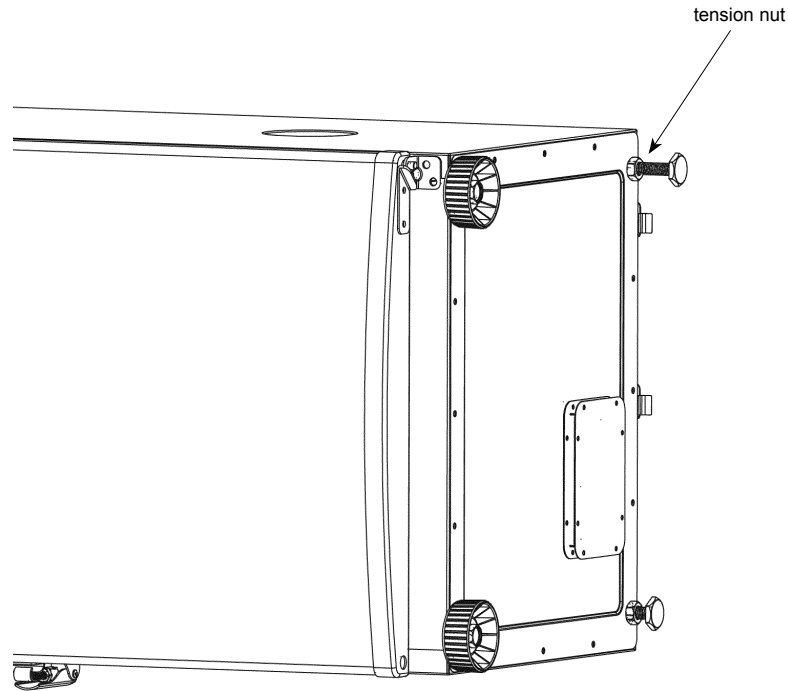

Step 1

Adjust feet by turning clockwise/counter-clockwise so that smoker is level when unit is upright. Once level, secure back leg positions with attached tension nuts.

Step 2

Position control panel to top of smoker.

Align slot on wire connector from control panel with tab on wire connector on smoker as shown and connect together.

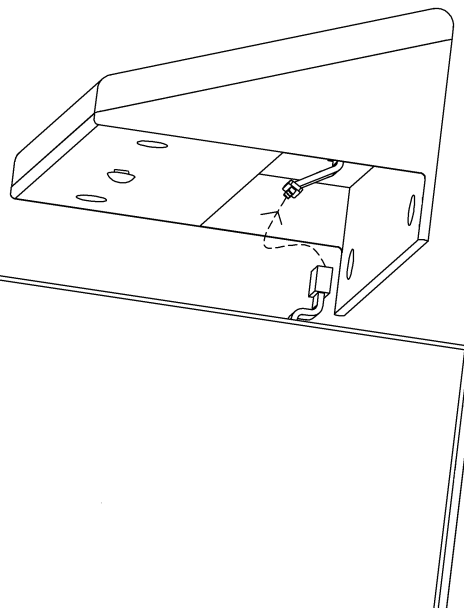

CONTROL PANEL OPERATING INSTRUCTIONS

Note: Direct sunlight may interfere with reading LED display, block light if needed.

To set temperature:

- Press ON button.
 - Press SET TEMP button once-LED display will blink.
 - Use +/- to set temperature.
 - Press SET TEMP button again to lock in temperature.
- Note:** Heating will not begin until timer is set.

To set timer:

- Press SET TIME button once-LED display for hours will blink.
- Use +/- to set hours.
- Press SET TIME button again to lock in hours. The minutes LED will start blinking.
- Use +/- to set minutes.
- Press SET TIME to lock in minutes and start cook cycle.

Heat will turn off when time has expired.

To RESET control panel:

If control panel shows an error message, turn electric smoker off, unplug unit from outlet, wait ten seconds, plug unit back into outlet, then turn electric smoker on. This will reset control panel.

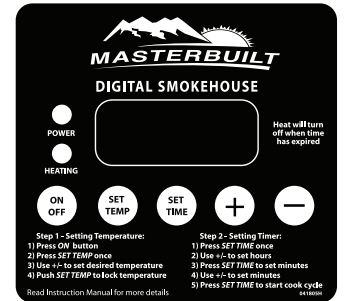

TROUBLESHOOTING GUIDE



Symptom	Cause	Possible Solution
Power light won't come on	Not plugged into wall	Check wall connection
	House fuse tripped	Make sure other appliances are not operating on the same electrical circuit. Check household fuses.
	Wire connector on controller not properly connected to smoker	See Step 2 on Page 5
	Controller malfunctioning	Contact Masterbuilt at 1.800.489.1581
Unit takes excessive amount of time to heat up (longer than 60-70 min)	Unit plugged into an extension cord	Set unit so an extension cord does not have to be used
	Door not closed properly	Close door and fasten latch securely
	Controller malfunctioning	Contact Masterbuilt at 1.800.489.1581
There is a gap between the door and the smoker when in use	Latch not holding door closed	Adjust latch to hold door tighter against body
	Door alignment	Contact Masterbuilt at 1.800.489.1581
	Damaged door seal	Contact Masterbuilt at 1.800.489.1581
Grease is leaking out of smoker through door and legs	Drip pan not in place	Reposition so hole lines up with drain hole in bottom of unit
	Excess grease or oil build-up in unit	Clean unit
	Drain tube in back of unit is not draining	Check drain tube positioning at back of unit
No smoke	No wood chips	Add wood chips See Page 9
Temperature rapidly decreased, or shut down after few hours of use	Faulty control unit	Contact Masterbuilt at 1.800.489.1581
Controller displaying error message	Controller malfunctioning	Contact Masterbuilt at 1.800.489.1581
Power light is on, unit isn't heating	Controller/unit malfunctioning	Contact Masterbuilt at 1.800.489.1581
Controller does not adjust heat	Controller/unit malfunctioning	Contact Masterbuilt at 1.800.489.1581

HOW TO USE WOOD CHIP LOADER

Before starting unit, place 1 cup of wood chips in chip loader.

Never use more than 1 cup of wood chips at a time.

Insert wood chip loader into smoker. Wood chips should be level with top rim of wood chip loader.

Turn handle to "Unload" mark on smoker. Wood will drop onto wood chip holder. Turn handle to "Load" and leave wood chip loader in place inside smoker.

Check wood chip holder periodically to see if wood has burned down by removing wood chip loader and looking into smoker through hole. Add more chips as needed.

Wood chip loader must be pulled out completely from smoker when checking wood chip level.

Adding more wood during smoking process:

Caution: Keep smoker door closed when adding wood chips.

Note: Wood chip loader will be HOT even if handle is not.

To add wood, turn handle to "Load" mark on smoker.

Pull wood chip loader from smoker.

Place wood chips in wood chip loader and re-insert into smoker.

Turn handle to "Unload" mark on smoker. Wood will drop onto wood chip holder.

Temperature may spike briefly after wood is added. It will stabilize after a short time. Do not adjust.

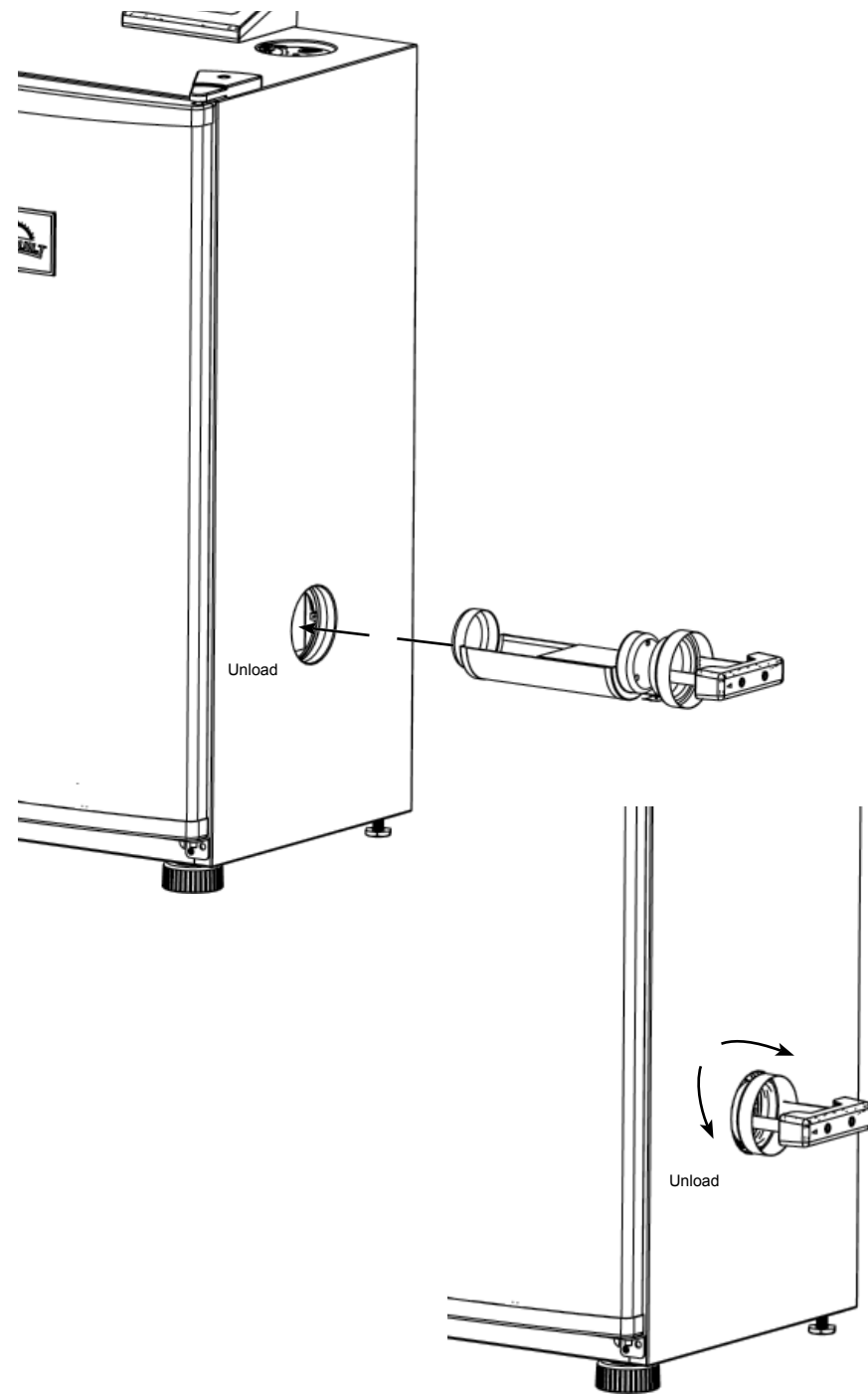

ASSEMBLY INSTRUCTIONS Continued

Step 3

Mount control panel by inserting stabilizing screw head into keyhole as shown.

Note: Stabilizing screw may need slight adjustment for snug fit.

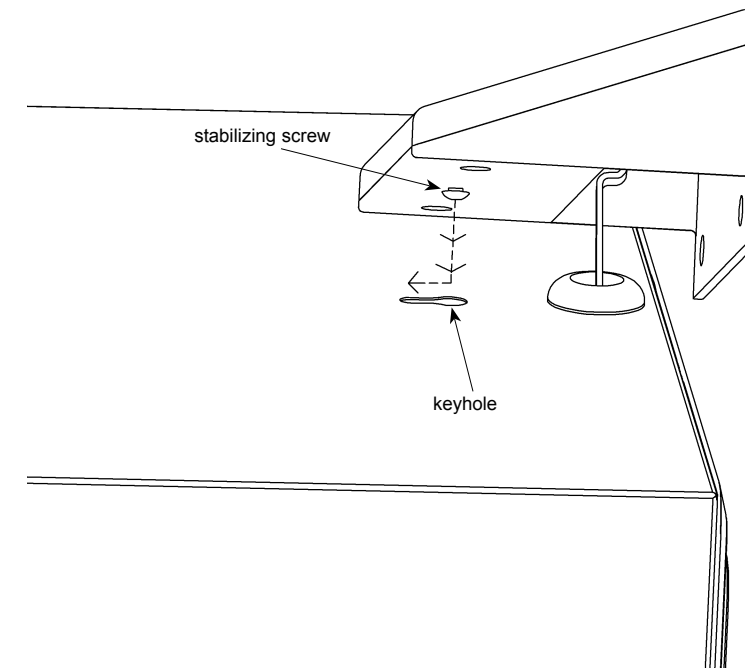

Step 4

Secure control panel to smoker with (2) m5X.08x10 panhead screws provided.

Note: Do not over tighten.

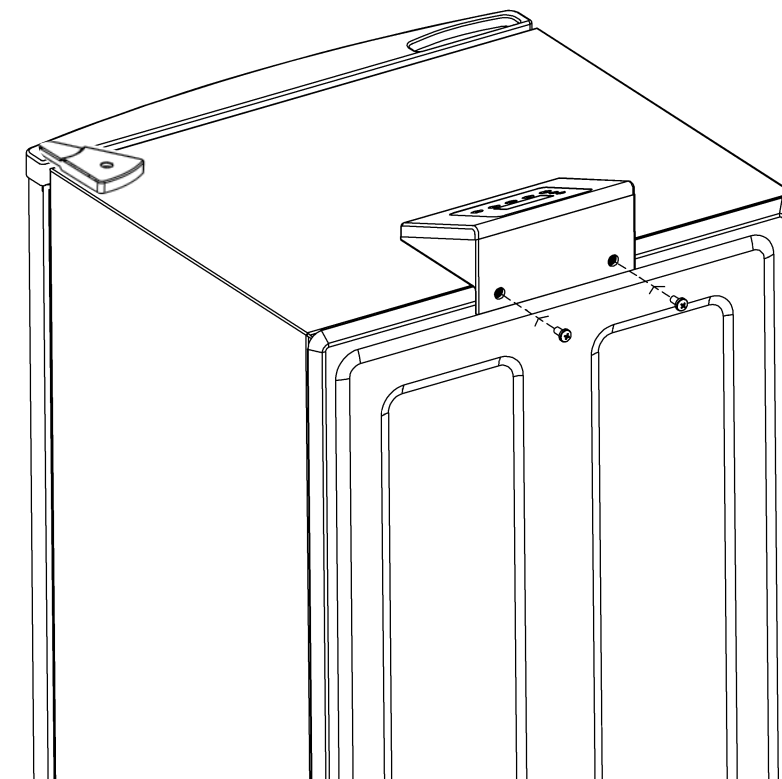

CAUTION



When door is opened a flare up may occur. Should wood chips flare up, immediately close door, wait for wood chips to burn down then open door again. Do not spray with water.

ASSEMBLY INSTRUCTIONS Continued

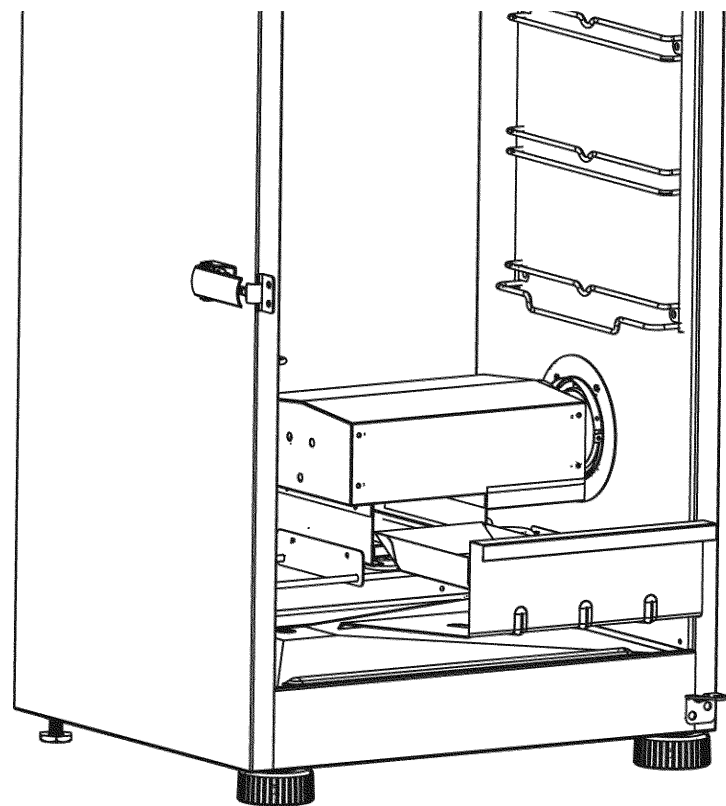

SOME PARTS NOT SHOWN FOR CLARITY.

Step 5

Place wood chip holder in smoker as shown.

Note: Wood chip holder and wood chip loader **MUST** be in place when using smoker. This minimizes the chance of wood flare ups.

ASSEMBLY INSTRUCTIONS Continued

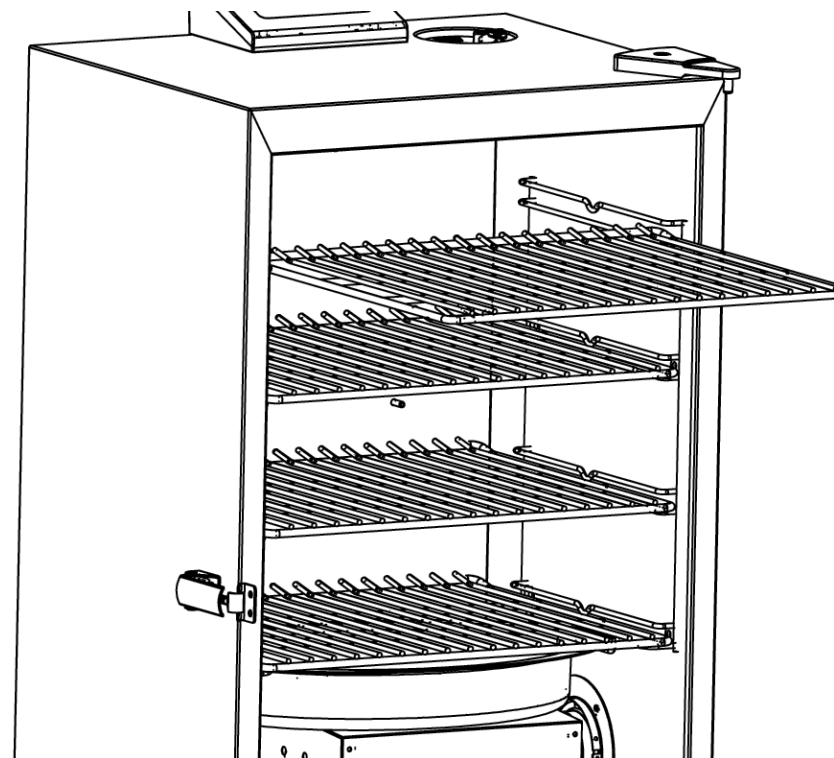

SOME PARTS NOT SHOWN FOR CLARITY.

Step 7

Slide cooking racks onto guides inside smoker.

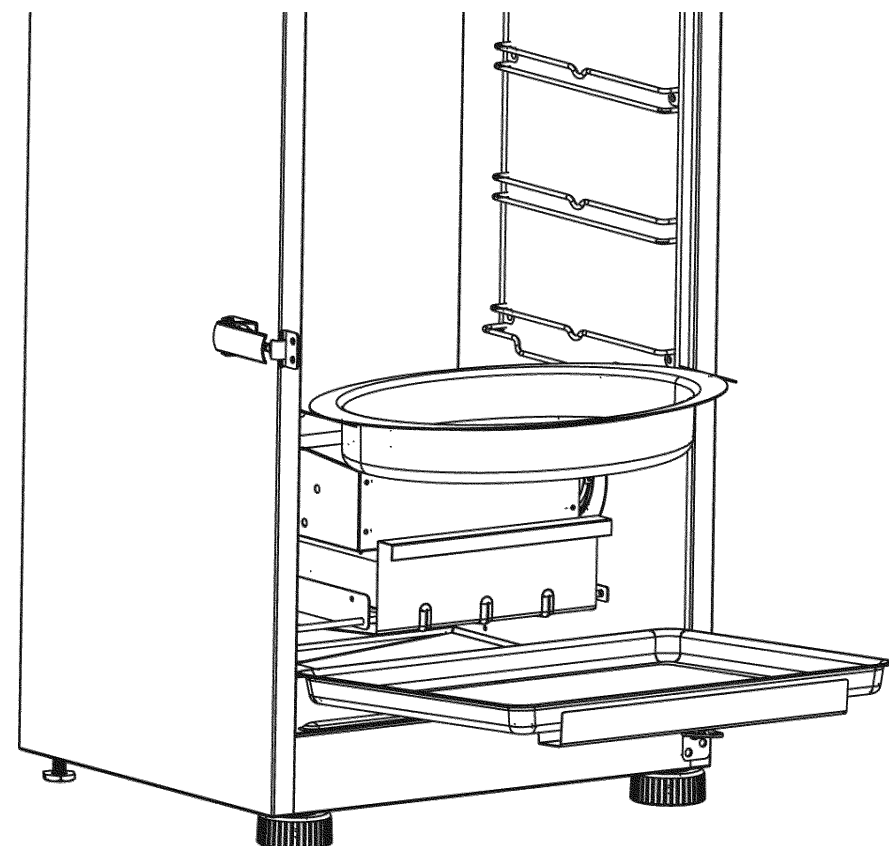

SOME PARTS NOT SHOWN FOR CLARITY.

Step 6

Place water bowl onto lower bracket inside smoker.

Place drip tray inside smoker below heating element as shown.

Note: Water bowl must always be in place during smoking process, even if there is no water or other liquid in bowl. Bowl will prevent food from dripping onto wood chips.

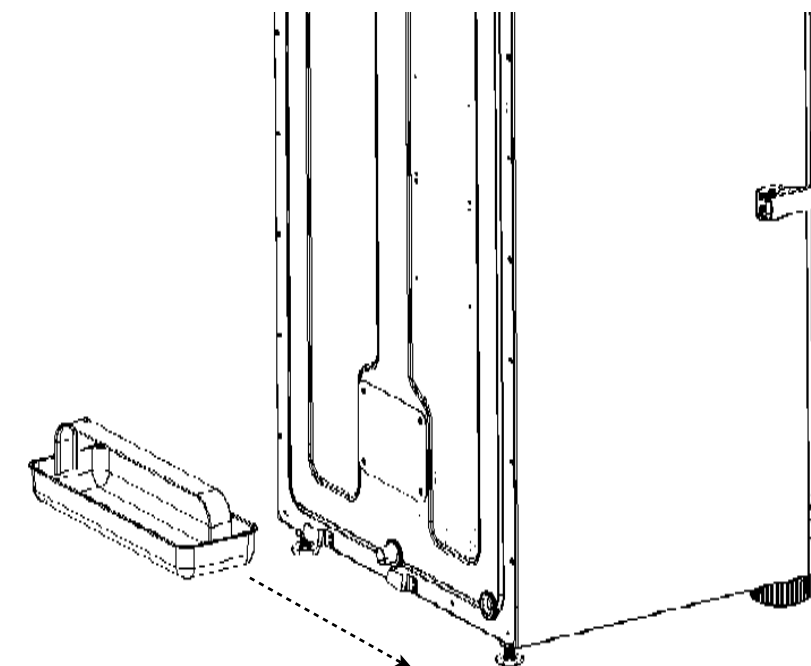

Step 8

Slide brackets on back of grease tray onto tabs on back of smoker body until grease tray stops.

PRESEASON INSTRUCTIONS

Preseason smoker prior to first use. Make sure water pan is in place with **NO WATER**. Set temperature to 275°F (135°C) and run unit for 3 hours. Shut down and allow to cool. Some smoke may appear during this time, this is normal.

During last 45 minutes, add 1 cup of wood chips in chip loader to complete preseasoning.

SMOKER IS READY TO USE