

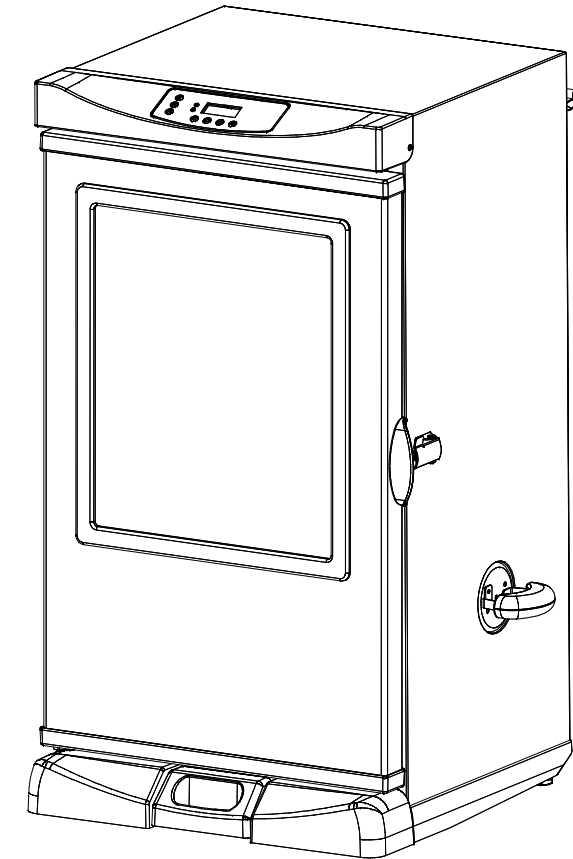

Masterbuilt Manufacturing, Inc.
 1 Masterbuilt Ct.
 Columbus, GA 31907
 Customer Service 1-800-489-1581
 www.masterbuilt.com







ASSEMBLY, CARE & USE MANUAL
WARNING & SAFETY INFORMATION
 ELECTRIC SMOKER MODELS 20070312, 20070512, 20072612, 20072712
 THIS PRODUCT IS FOR OUTDOOR USE ONLY



Manual Code: 9807120001 031612-23JH

Approximate assembly time : 25 minutes

Tool needed for assembly: Phillips Head Screwdriver

 CARBON MONOXIDE HAZARD 	 WARNING 
<p>Burning wood chips gives off carbon monoxide, which has no odor and can cause death.</p> <p>DO NOT burn wood chips inside homes, vehicles, tents, garages or any enclosed areas.</p> <p>Use only outdoors where it is well ventilated.</p>	<p>This manual contains important information necessary for the proper and safe use of this unit.</p> <p>Read and follow all warnings and instructions before using smoker and during use.</p> <p>Keep this manual for future reference.</p> <p>Some parts may have sharp edges handle with care.</p>
<p>Failure to follow these warnings and instructions properly could result in personal injury or death.</p>	



GENERAL WARNINGS AND SAFETY INFORMATION



READ ALL INSTRUCTIONS

When using electrical appliances, basic safety precautions should always be followed including the following:

- For outdoor use only. Do not operate in an enclosed area.
- Unit **MUST** be on the ground. Do not place unit on tables or counters. Do **NOT** move unit across uneven surfaces.
- Do not lift unit by rear handle.
- Do not plug in electric smoker until fully assembled and ready for use.
- Use only approved grounded electrical outlet.
- Do not use during an electrical storm.
- Do not expose electric smoker to rain or water at anytime.
- To protect against electrical shock do not immerse cord, plug or control panel in water or other liquid.
- Do not operate any appliance with a damaged cord or plug, or after appliance malfunctions or has been damaged in any manner. Contact Masterbuilt Customer Service for assistance at 1-800-489-1581.
- Keep a fire extinguisher accessible at all times while operating electric smoker.
- Do not let cord hang touch hot surfaces.
- Do not place on or near a hot gas or electric burner, or in a heated oven.
- Keep children and pets away from electric smoker at all times. Do not allow children to use electric smoker. Close supervision is necessary should children or pets be in area where electric smoker is being used.
- Fuel, such as charcoal briquettes or heat pellets, are not to be used in electric smoker.
- Never use electric smoker as a heater (READ CARBON MONOXIDE HAZARD ON FRONT COVER).
- Use electric smoker only on a level, stable surface to prevent tipping.
- Electric smoker is **HOT** while in use and will remain **HOT** for a period of time afterwards. Use caution.
- Do not touch **HOT** surfaces.
- Do not allow anyone to conduct activities around electric smoker during or following its use until the unit has cooled. Electric smoker is **HOT** during operation and remains **HOT** for a period of time following use.
- The use of alcohol, prescription or non-prescription drugs may impair the user's ability to properly assemble or safely operate electric smoker.
- Avoid bumping or impacting electric smoker.
- Never move electric smoker when in use. Allow electric smoker to cool completely before moving or storing.
- Be careful when removing food from electric smoker. All surfaces are **HOT** and may cause burns. Use protective gloves or long, sturdy cooking tools.

WARNINGS & IMPORTANT SAFEGUARDS CONTINUED ON PAGE 2

LIMITED WARRANTY

Masterbuilt warrants its products to be free from defects in material and workmanship under proper assembly, normal use and recommended care for 90 days from the date of original retail purchase. Masterbuilt warranty does not cover paint finish as it may burn off during normal use. Masterbuilt warranty does not cover rust of the unit.

Masterbuilt requires reasonable proof of purchase for warranty claims and suggests that you keep your receipt. Upon the expiration of such warranty, all such liability shall terminate.

Within the stated warranty period, Masterbuilt, at its discretion, shall repair or replace defective components free of charge with owner being responsible for shipping. Should Masterbuilt require return of component(s) in question for inspection Masterbuilt will be responsible for shipping charges to return requested item. This warranty excludes property damage sustained due to misuse, abuse, accident, damage arising out of transportation, or damage incurred by commercial use of this product.

This expressed warranty is the sole warranty given by Masterbuilt and is in lieu of all other warranties, expressed or implied including implied warranty, merchantability, or fitness for a particular purpose. Neither Masterbuilt nor the retail establishment selling this product, has authority to make any warranties or to promise remedies in addition to or inconsistent with those stated above.

Masterbuilt's maximum liability, in any event, shall not exceed the purchase price of the product paid by the original consumer/ purchaser. Some states do not allow the exclusion or limitation of incidental or consequential damages. In such a case, the above limitations or exclusions may not be applicable.

California residents only: Notwithstanding this limitation of warranty, the following specific restrictions apply; if service, repair, or replacement of the product is not commercially practical, the retailer selling the product or Masterbuilt will refund the purchase price paid for the product, less the amount directly attributable to use by the original buyer prior to the discovery of the nonconformity. Owner may take the product to the retail establishment selling this product in order to obtain performance under warranty. This expressed warranty gives you specific legal rights, and you may also have other rights which vary from state to state.



Go Online www.masterbuilt.com

or complete and return to

Attn: Warranty Registration

Masterbuilt Mfg. Inc.

1 Masterbuilt Court - Columbus, GA 31907

Name: _____ Address : _____ City: _____

State/Province: _____ Postal Code: _____ Phone Number: (____) - _____

E-mail Address: _____

*Model Number: _____ *Serial Number: _____

Purchase Date: ____ - ____ - ____ Place of Purchase: _____

**Model Number and Serial Number are located on silver label on back of unit.*

This device complies with Part 15 of the FCC Rules. Operation is subject to the following two conditions :

- (1) this device may not cause harmful interference, and
- (2) this device must accept any interference received, including interference that may cause undesired operation.

FCC Warning

Warning: Changes or modifications to this unit not expressly approved by the party responsible for compliance could void the user's authority to operate the equipment.

FCC Statement

NOTE: This equipment has been tested and found to comply with the limits for a Class B digital device, pursuant to Part 15 of the FCC Rules. These limits are designed to provide reasonable protection against harmful interference in a residential installation. This equipment generates uses and can radiate radio frequency energy and, if not installed and used in accordance with the instructions, may cause harmful interference to radio communications.

However, there is no guarantee that interference will not occur in a particular installation. If this equipment does cause harmful interference to radio or television reception, which can be determined by turning the equipment off and on, the user is encouraged to try to correct the interference by one or more of the following measures:

1. Reorient or relocate the receiving antenna.
2. Increase the separation between the equipment and receiver.
3. Connect the equipment into an outlet on a circuit different from that to which the receiver is connected.
4. Consult the dealer or an experienced radio/TV technician for help.



GENERAL WARNINGS AND SAFETY INFORMATION



- **Do not cover cooking racks with metal foil. This will trap heat and cause severe damage to electric smoker.**
- **Drip tray is only for the bottom of electric smoker. Do not put drip tray on cooking racks this may damage electric smoker.**
- **Wood tray is HOT when electric smoker is in use. Use caution when adding wood.**
- **To disconnect, turn control panel "OFF" then remove plug from outlet.**
- **Unplug from outlet when not in use and before cleaning. Allow unit to cool completely before adding/removing grates, tray or water bowl.**
- **Dispose of cold ashes by placing them in aluminum foil, soaking with water and discarding in a non-combustible container.**
- **Do not store electric smoker with HOT ashes inside unit. Store only when all surfaces are cold.**
- **Accessory attachments not supplied by Masterbuilt Manufacturing, Inc. are not recommended and may cause injury.**
- **The use of accessory attachments not recommended by the appliance manufacturer may cause injuries.**
- **Never use electric smoker for anything other than its intended purpose. This unit is not for commercial use.**
- **Always use electric smoker in accordance with all applicable local, state and federal fire codes.**
- **Longer detachable power-supply cords or extension cords are available and may be used if care is exercised in their use.**
- **If a longer detachable power-supply cord or extension cord is used: 1. The marked electrical rating of the cord set or extension cord should be at least as great as the electrical rating of the appliance; and 2. The cord should be arranged so that it will not drape over the counter top or tabletop where it can be pulled by children or tripped over intentionally.**
- **The extension cord must be a grounding -type 3-wire cord.**
- **Outdoor extension cords must be used with outdoor use products and are marked with suffix "W" and with the statement "Suitable for Use with Outdoor Appliances.**
- **CAUTION - To reduce the risk of electric shock, keep extension cord connection dry and off the ground.**
- **Extreme caution must be used when moving an appliance containing hot liquids.**
- **Do not clean this product with a water sprayer or the like.**

SAVE THESE INSTRUCTIONS



WARNING



COMBUSTION BY-PRODUCT PRODUCED WHEN USING THIS PRODUCT CONTAINS CHEMICALS KNOWN TO THE STATE OF CALIFORNIA TO CAUSE BIRTH DEFECTS, OTHER REPRODUCTIVE HARM, OR CANCER.

THE MATERIALS USED IN THIS PRODUCT MAY CONTAIN LEAD A CHEMICAL KNOWN TO THE STATE OF CALIFORNIA TO CAUSE BIRTH DEFECTS AND OTHER REPRODUCTIVE HARM.

LET'S GET STARTED!

- This is a slow smoker...allow sufficient time for cooking. Smoker is for OUTDOOR USE ONLY.
- "Preseason" smoker prior to first use. See page 12.
- Pre-heat smoker for 30 to 45 minutes at max temperature before loading food.
- DO NOT cover racks with aluminum foil as this will not allow heat to circulate properly.
- Do not overload smoker with food. Extra large amounts of food may trap heat, extend cooking time and cause uneven cooking. Leave space between food on racks and smoker sides to ensure proper heat circulation. If utilizing cooking pans, place pans on center of rack to ensure even cooking. Please see manual for more detail.
- Close air damper on side of unit to retain moisture and heat. If cooking foods such as fish or jerky, open air damper to release moisture.
- Temperature reading on control panel will fluctuate + or - 10 to 15 degrees as smoker cycles on and off.
- Store smoker in a dry area after use.
- Extreme cold temperatures may extend cooking times.
- CLEAN AFTER EVERY USE. This will extend the life of your smoker and prevent mold and mildew.

ENJOY!

IMPORTANT FACTS ABOUT USING SMOKER

- Maximum temperature setting is 275°F (135°C).
- Do NOT move unit across uneven surfaces.
- Rear handle is NOT for lifting.
- Wood chip loader and wood chip tray MUST be in place when using smoker. This minimizes the chance of wood flare ups.
- Wood chips must be used in order to produce smoke and create the smoke flavor.
- Check grease tray often during cooking. Empty grease tray before it gets full. Grease tray may need to be emptied periodically during cooking.
- Do not open smoker door unless necessary. Opening smoker door causes heat to escape and may cause wood to flare up. Closing the door will re-stabilize the temperature and stop flare up.
- Do not leave old wood ashes in the wood chip tray. Once ashes are cold, empty tray. Tray should be cleaned out prior to, and after each use to prevent ash buildup.
- Glass in door is tempered and will not break under normal operation.
- This is a smoker. There will be a lot of smoke produced when using wood chips. Smoke will escape through seams and turn the inside of smoker black. This is normal. To minimize smoke loss around door, door latch can be adjusted to further tighten door seal against body.
- Opening smoker door during cooking process may extend cooking time due to heat loss.
- When outside temperature is cooler than 65°F (18°C) and/or altitude is above 3,500 feet (1067m), additional cooking time may be required. To insure that meat is completely cooked use a meat thermometer to test internal temperature.

- To adjust door latch, loosen hex nut on door latch. Turn hook clockwise to tighten as shown. Secure hex nut firmly against door latch.

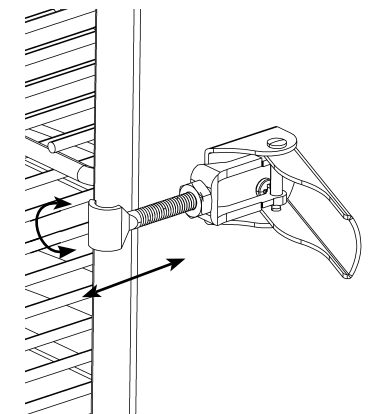

HOW TO CLEAN SMOKER

For grate supports, smoking racks, water bowl and drip pan use a mild dish detergent. Rinse and dry thoroughly.

For wood chip tray and wood chip loader, clean frequently to remove ash build up, residue and dust.

Dispose of cold ashes by placing them in aluminum foil, soaking with water and discarding in a non-combustible container.

For the interior, glass in door, meat probe, and exterior of smoker simply wipe down with a damp cloth. Do not use a cleaning agent. Make sure to dry thoroughly.

Door seal and inside seam that seal attaches to MUST be cleaned with a damp cloth after each use to keep seal in proper working condition.

ALWAYS MAKE SURE UNIT IS UNPLUGGED AND COOL TO THE TOUCH BEFORE CLEANING AND STORING.

TROUBLESHOOTING GUIDE

SYMPTOM	CAUSE	POSSIBLE SOLUTION
Power light won't come on	Not plugged into wall	Check wall connection
	House fuse tripped	Make sure other appliances are not operating on the same electrical circuit. Check household fuses.
	Controller malfunctioning	Contact Masterbuilt at 1.800.489.1581
Unit takes excessive amount of time to heat up (longer than 60-70 min)	Unit plugged into an extension cord	Set unit so an extension cord does not have to be used
	Door not closed properly	Close door and fasten latch securely
	Controller malfunctioning	Contact Masterbuilt at 1.800.489.1581
There is a gap between the door and the smoker when in use and door latch has no more adjustment	Door alignment	Contact Masterbuilt at 1.800.489.1581
	Damaged door seal	Contact Masterbuilt at 1.800.489.1581
Grease is leaking out of smoker through door and legs	Drip pan not in place	Reposition so hole lines up with drain hole in bottom of unit
	Excess grease or oil build-up in unit	Clean unit
	Drain tube is not draining	Check drain tube
No smoke	No wood chips	Add wood chips (See Page 12)
Temperature rapidly decreased or shut down after few hours of use	Faulty control unit	Contact Masterbuilt at 1.800.489.1581
Controller displaying error message	Controller malfunctioning	Contact Masterbuilt at 1.800.489.1581
Power light is on, unit isn't heating	Controller/unit malfunctioning	Contact Masterbuilt at 1.800.489.1581
Controller does not adjust heat	Controller/unit malfunctioning	Contact Masterbuilt at 1.800.489.1581
Meat probe temperature does not show on display	Probe malfunctioning	Contact Masterbuilt at 1.800.489.1581
Remote will not control smoker	Batteries are weak or installed wrong	Refer to page 13 instructions
	Remote is not linked properly to controller	Contact Masterbuilt at 1.800.489.1581
	Remote malfunctioning	Contact Masterbuilt at 1.800.489.1581



DO NOT RETURN TO RETAILER For Assembly Assistance, Missing or Damaged Parts
 Call: MASTERBUILT Customer Service at 1-800-489-1581.
 Please have Model Number and Serial Number available when calling.
 These numbers are located on silver label on back of unit.

PARTS LIST

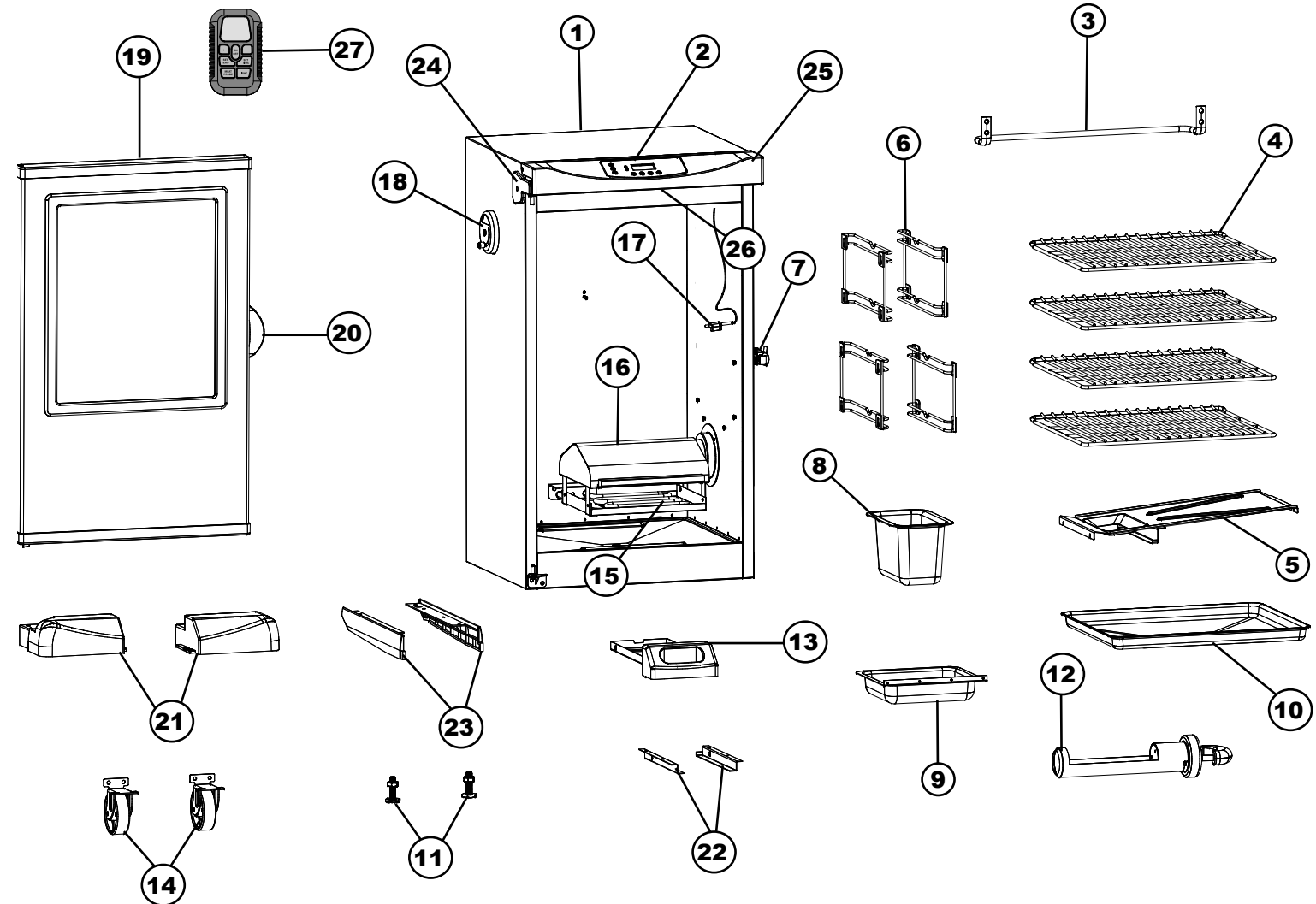

PART NO	QTY	DESCRIPTION	PART NO	QTY	DESCRIPTION
1	1	Smoker Body	14	2	Wheel
2	1	Control Panel	15	1	Element
3	1	Rear Handle	16	1	Wood Chip Lid
4	4	Smoking Rack	17	1	Meat Probe
5	1	Drip Deflector	18	1	Air Damper
6	4	Grate Supports	19	1	Door w/ Window
7	1	Door Latch	20	1	Door Handle
8	1	Water Bowl	21	2	Front Foot
9	1	Wood Chip Tray	22	2	Grease Tray Bracket
10	1	Drip Pan	23	2	Side Panel
11	2	Adjustable Screw Leg	24	1	Door Hinge
12	1	Wood Chip Loader	25	1	Control Panel Housing
13	1	Grease Tray	26	1	LED Light
			27	1	Remote Control

HARDWARE LIST



(A)
M6x25
Screw
Qty: 16



(B)
ST4x10
Screw
Qty: 8



(C)
M6x9
Screw
Qty: 8

PARTS LIST

MODEL 20070312		
PART NO	REPLACEMENT PART	ITEM NO
1	Body Kit, Black	9907120003
2	Digital Smoker Control	9007120007
3	Rear Handle Kit	9907120015
4	Smoking Rack	9007120002
5	Drip Deflector Pan	9007120003
6	Cooking Grate Support	9007120001
7	Door Latch Kit, Black	9907120004
8	Water Bowl	9007120004
9	Wood Chip Tray	9007120006
10	Drip Pan	9007120009
11	Adjustable Screw Leg	910050006
12	Wood Chip Loader	9007120005
13	Grease Tray	9007120019
14	Wheel Kit	9907120017
15	Element Kit, 800 Watt	9907120011
16	Wood Chip Housing Kit	9907120014
18	Air Damper Kit	9907120005
19	30" Door Kit, SS	9907120001
20	Door Handle Kit	9907120012
21	Right Front Foot Kit	9907120006
	Left Front Foot Kit	9907120007
22	Grease Tray Bracket Kit	9907120016
23	Right Trim Panel Kit	9907120009
	Left Trim Panel Kit	9907120010
24	Door Hinge Kit	9907120013
	Hinge Cover Kit	9907120008
25	Control Panel Housing Kit	9907120002
26	LED Light Kit	9907120018
27	Digital Remote	9007120008
	Hardware Kit	9907120019
	Instruction Manual	9807120001

MODELS 20070512, 20072612, 20072712		
PART NO	REPLACEMENT PART	ITEM NO
1	Body Kit, Black	9907120022
2	Digital Smoker Control	9007120015
3	Rear Handle Kit	9907120028
4	Smoking Rack	9007120012
5	Drip Deflector Pan	9007120013
6	Cooking Grate Support	9007120011
7	Door Latch Kit, Black	9907120004
8	Water Bowl	9007120014
9	Wood Chip Tray	9007120006
10	Drip Pan	9007120016
11	Adjustable Screw Leg	910050006
12	Wood Chip Loader	9007120005
13	Grease Tray	9007120018
14	Wheel Kit	9907120017
15	Element Kit, 1200 Watt	9907120027
16	Wood Chip Housing Kit	9907120014
18	Air Damper Kit	9907120005
19	40" Door Kit, SS	9907120020
20	Door Handle Kit	9907120012
21	Right Front Foot Kit	9907120023
	Left Front Foot Kit	9907120024
22	Grease Tray Bracket Kit	9907120016
23	Right Trim Panel Kit	9907120025
	Left Trim Panel Kit	9907120026
24	Door Hinge Kit	9907120013
	Hinge Cover Kit	9907120008
25	Control Panel Housing Kit	9907120021
26	LED Light Kit	9907120018
27	Digital Remote	9007120008
	Hardware Kit	9907120019
	Instruction Manual	9807120001

DO NOT RETURN TO RETAILER For Assembly Assistance, Missing or Damaged Parts
Call: MASTERBUILT Customer Service at 1-800-489-1581.
Please have Model Number and Serial Number available when calling.
These numbers are located on silver label on back of unit.

STOP!

HOW TO USE CONTROL PANEL & REMOTE CONTROL

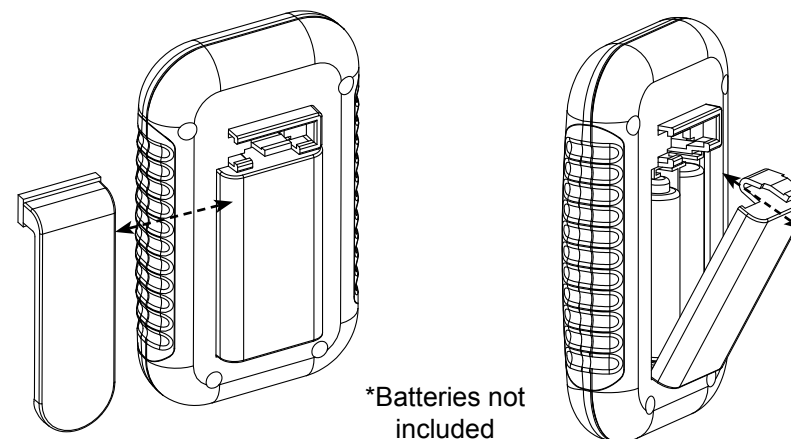

*Batteries not included

To replace batteries:

- Slide belt clip to the left to remove.
- Press tab down on battery cover and pull out.
- Install 2 "AAA" Alkaline batteries. Check positive (+) and negative (-) symbols, on the case and battery, to insure proper installation.
- Replace the battery cover.
- Remove batteries before storing remote control.

To test frequency range:

- Turn unit on.
- Use remote to turn light on and off as you move away from unit.
- Remote control is out of frequency range when light will no longer turn on and off.

IMPORTANT

- Do not leave remote control exposed to sunlight for prolonged periods of time.
- Remote control has frequency range of up to 100ft (30m).
- Test frequency range before and during use.

TROUBLESHOOTING

If the remote is not working properly or not interfacing correctly with the controller, it may be due to weak batteries, batteries being incorrectly installed or the remote is not correctly linked to controller.

Possible solutions

- Replace batteries and install according to image in battery housing
- Link remote and controller by:
 - a. Turn Controller & Remote "OFF",
 - b. Press and HOLD "SET TEMP" on controller for 3 seconds.
 - c. On the Remote press "MEAT PROBE", "LIGHT", "MEAT PROBE", "LIGHT" (*all buttons must be pressed within 5 seconds of each other*) A short beep will occur after each button press.

CAUTION

- Keep batteries away from small children. If battery is swallowed consult a physician immediately.
- Be sure to insert batteries correctly. Improper installation may result in leaks and/or possible explosion.
- Do not dispose of batteries in fire.
- Do not mix old and new batteries.
- Do not mix alkaline, standard (carbon-zinc), or rechargeable (ni-cad, ni-mh, etc) batteries.

HOW TO USE CONTROL PANEL & REMOTE CONTROL

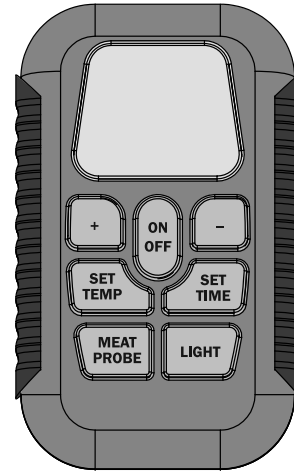
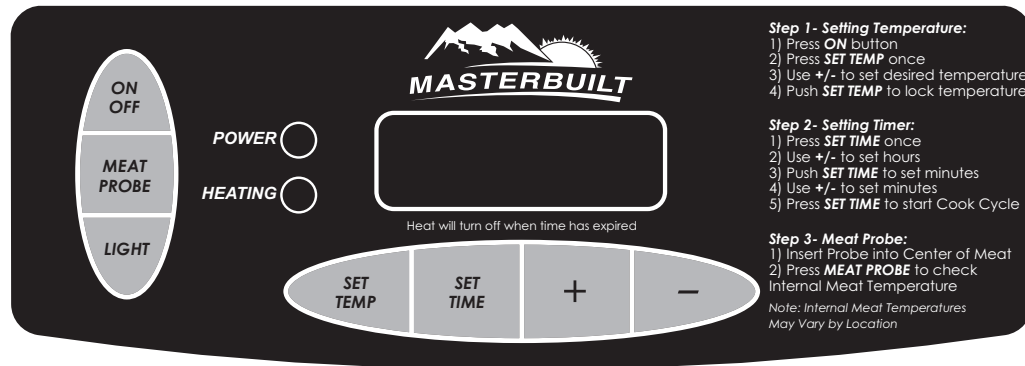

Note: Direct sunlight may interfere with ability to read LED display, block light if needed.

To set temperature:

- Press ON button.
- Press SET TEMP button once-LED display will blink.
- Use +/- to set temperature.
- Press SET TEMP button again to lock in temperature.

Note: Heating will not begin until timer is set.

To set timer:

- Press SET TIME button once-LED display for hours will blink.
- Use +/- to set hours.
- Press SET TIME button again to lock in hours. The minutes LED will start blinking.
- Use +/- to set minutes.
- Press SET TIME to lock in minutes and start cook cycle.

Heat will turn off when time has expired.

To use meat probe:

- Insert meat probe into center of meat to get most accurate reading.
- Press and hold MEAT PROBE button-LED display will show internal temperature of meat.
- Once MEAT PROBE button is released-LED display will return to set temperature or set time.

To use light:

- Press LIGHT button to turn light on.
- Press LIGHT button to turn light off.

To RESET control panel:

If control panel shows an error message, turn electric smoker off, unplug unit from outlet, wait ten seconds, plug unit back into outlet, then turn electric smoker on. This will reset control panel.

ASSEMBLY

- BEFORE ASSEMBLY READ ALL INSTRUCTIONS CAREFULLY.
- ASSEMBLE UNIT ON A CLEAN, FLAT SURFACE.
- TOOL NEEDED: PHILLIPS HEAD SCREWDRIVER

****Some assembly steps may already be completed due to pre-assembly at the factory.****

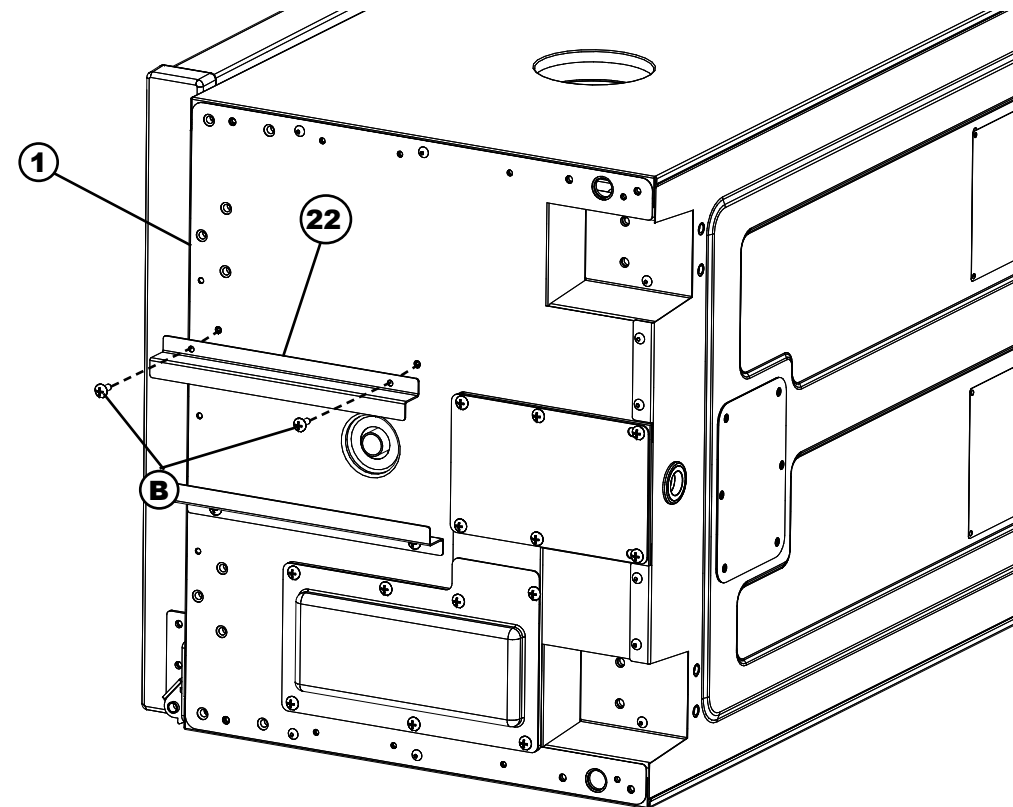

STEP 1

Remove all components on inside of smoker before beginning assembly.

Carefully position smoker on side as shown. Alternatively, the smoker can be positioned upside down for assembly. However, make sure styrofoam packaging remains on top to prevent damage to control panel.

Attach grease tray bracket (22) to bottom of smoker body (1) using screws (B).

Repeat step for remaining grease tray bracket.

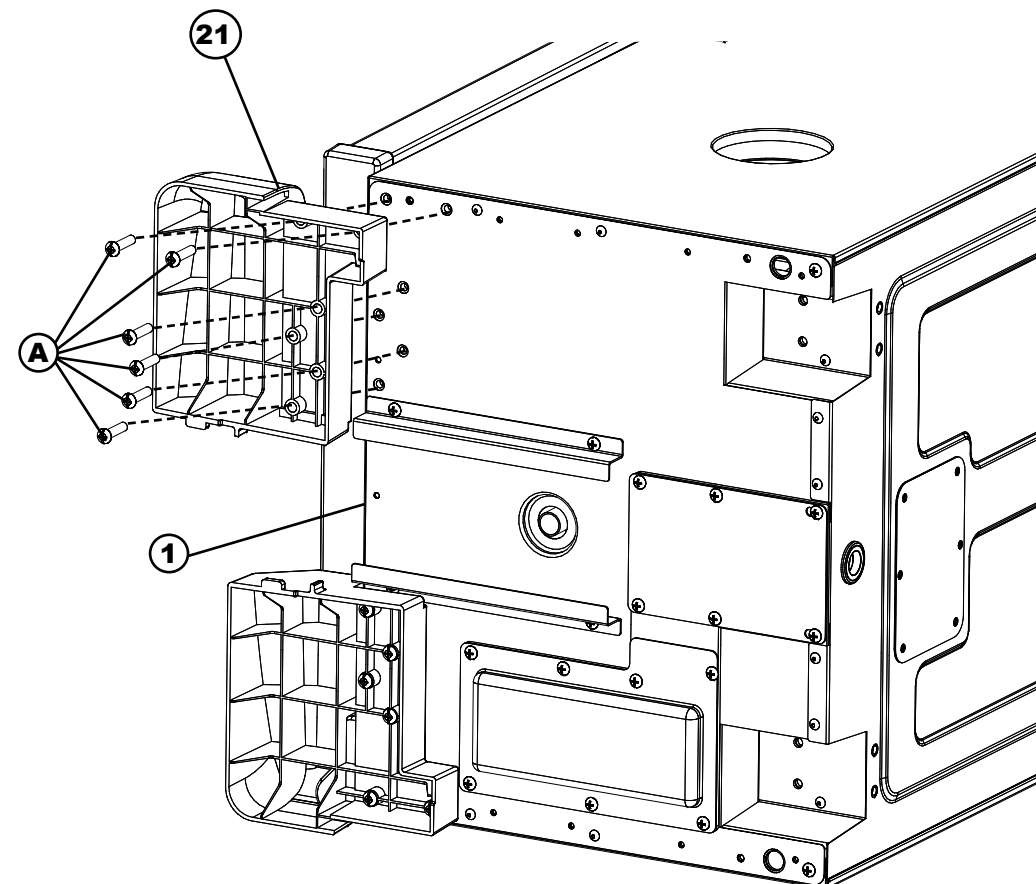

STEP 2

Secure front foot (21) to bottom of smoker body (1) using screws (A).

Repeat step on opposite side for remaining front foot.

ASSEMBLY

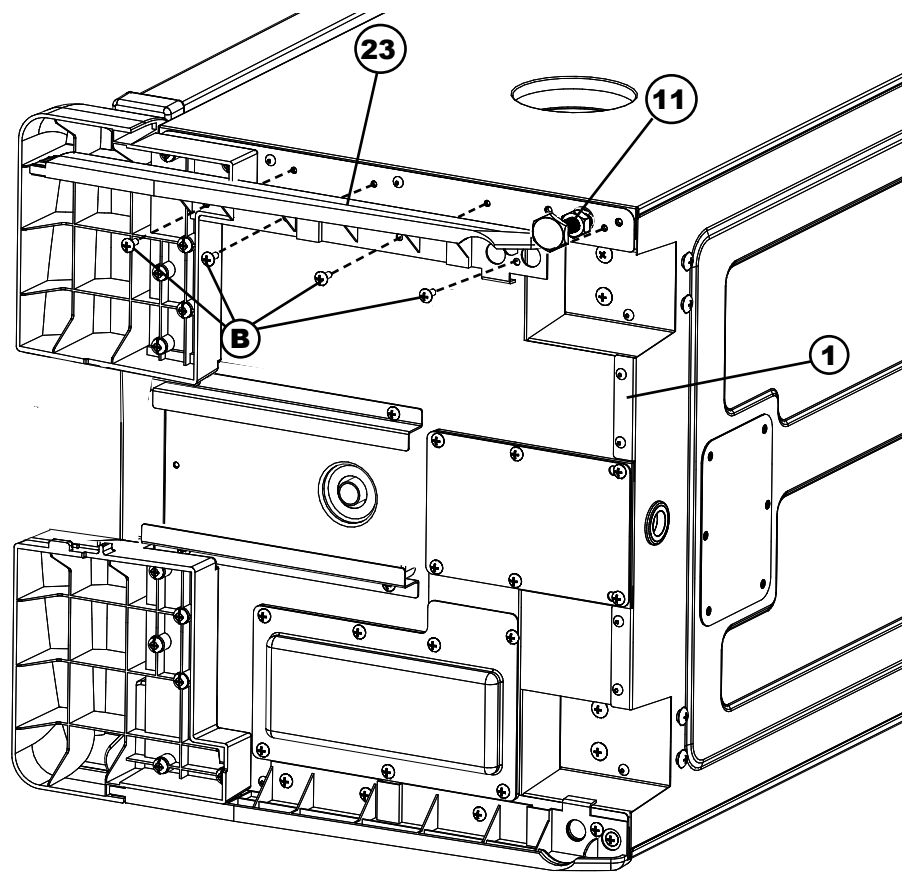

STEP 3

Remove adjustable screw leg (11). Set aside to be used in Step 5.

Attach side panel (23) to smoker body (1) using screws (B) as shown.

Repeat step on opposite side for remaining side panel.

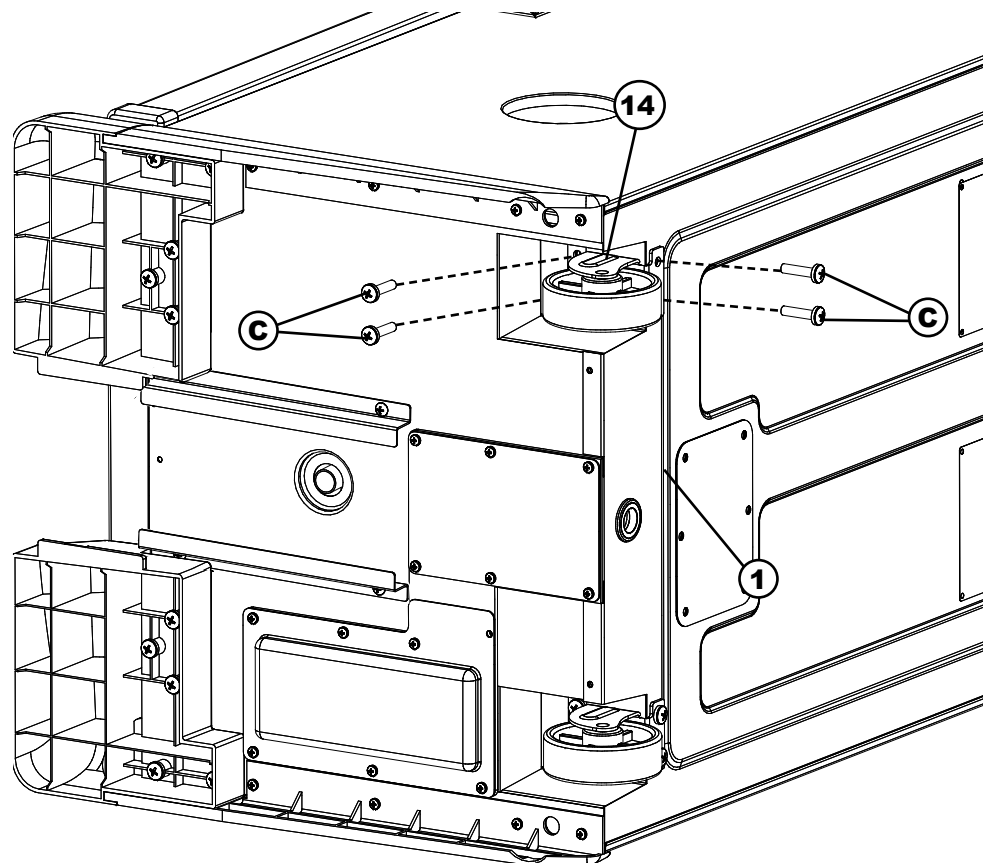

STEP 4

Position wheel (14) on bottom of smoker body (1) as shown. Secure using screws (C).

Repeat step on opposite side for remaining wheel.

PRESEASON INSTRUCTIONS

1. Make sure water pan is in place with NO WATER.
2. Set temperature to 275°F (135°C) and run unit for 3 hours.
3. Shut down and allow to cool. Some smoke may appear during this time, this is normal.
4. During last 45 minutes, add 1 cup of wood chips in chip loader to complete preseasoning.

HOW TO USE WOOD CHIP LOADER

Before starting unit, place 1 cup of wood chips in chip loader.

Never use more than 1 cup of wood chips at a time. Never use wood chunks.

Insert wood chip loader into smoker. Wood chips should be level with top rim of wood chip loader.

Turn handle to "Unload" mark on smoker. Wood will drop onto wood chip tray. Turn handle to "Load" and leave wood chip loader in place inside smoker.

Check wood chip tray periodically to see if wood has burned down by removing wood chip loader and looking into smoker through hole. Add more chips as needed.

Wood chip loader must be pulled out completely from smoker when checking wood chip level.

ADDING MORE WOOD DURING SMOKING PROCESS:

Caution: Keep smoker door closed when adding wood chips.

Note: Wood chip loader will be HOT even if handle is not.

To add wood, turn handle to "Load" position on smoker.

Pull wood chip loader from smoker.

Place wood chips in wood chip loader and re-insert into smoker.

Turn handle to "Unload" mark on smoker. Wood will drop onto wood chip tray.

Temperature may spike briefly after wood is added. It will stabilize after a short time. Do not adjust temperature setting.

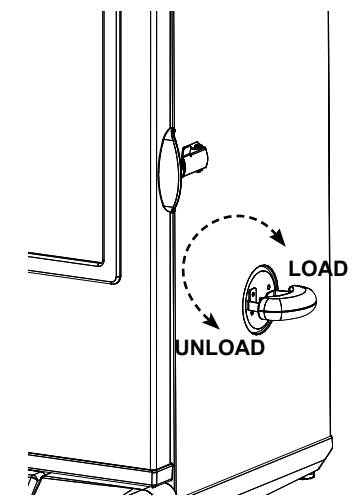

CAUTION

When door is opened a flare up may occur. Should wood chips flare up, immediately close door, wait for wood chips to burn down then open door again. Do not spray with water.

ASSEMBLY

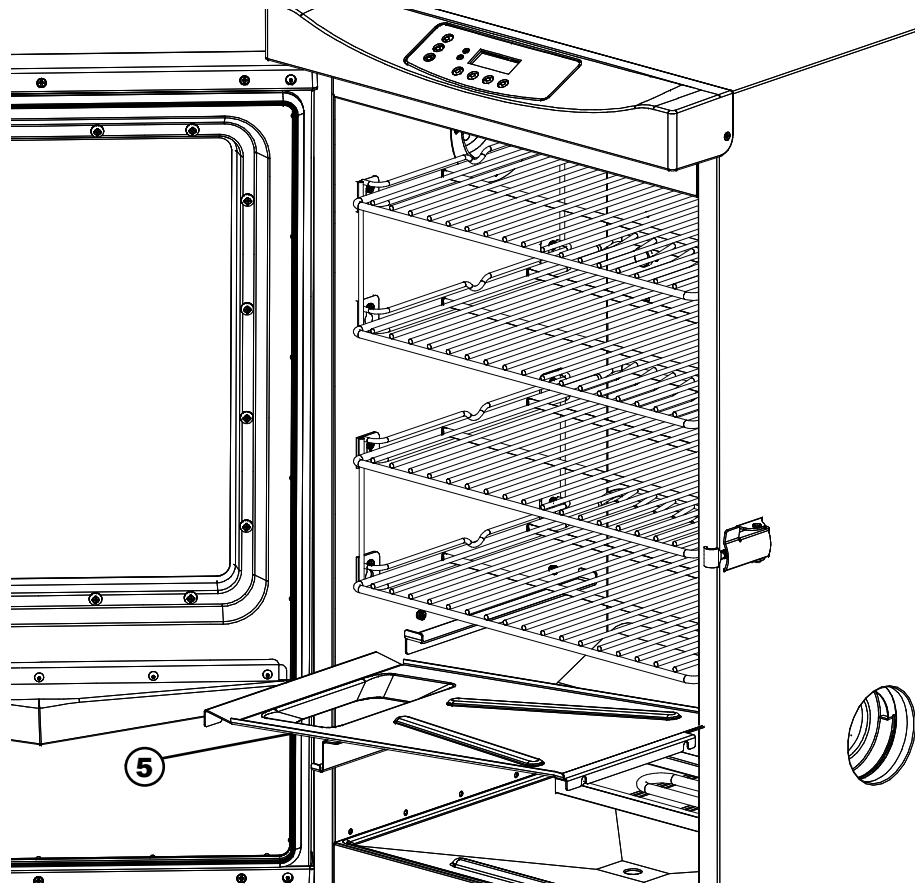

STEP 11

Align keyholes on drip deflector (5) with studs on the inside of smoker body. Press drip deflector down to secure in place.

ASSEMBLY

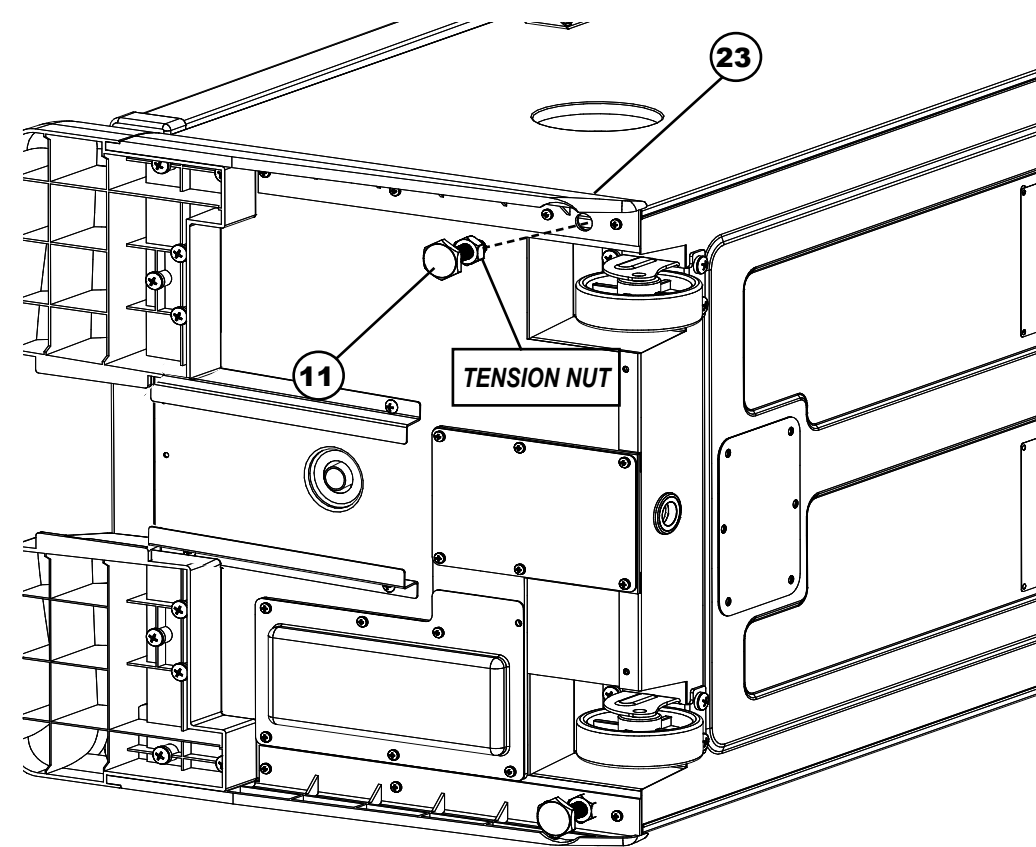

STEP 5

Insert adjustable screw leg (11) through bottom of side panel (23) as shown, and into smoker body.

Repeat step on opposite side for remaining adjustable screw leg.

Note: When unit is upright, set adjustable screw leg height by turning clockwise/counterclockwise, so that smoker is level. Once level, secure leg positions by tightening tension nuts.

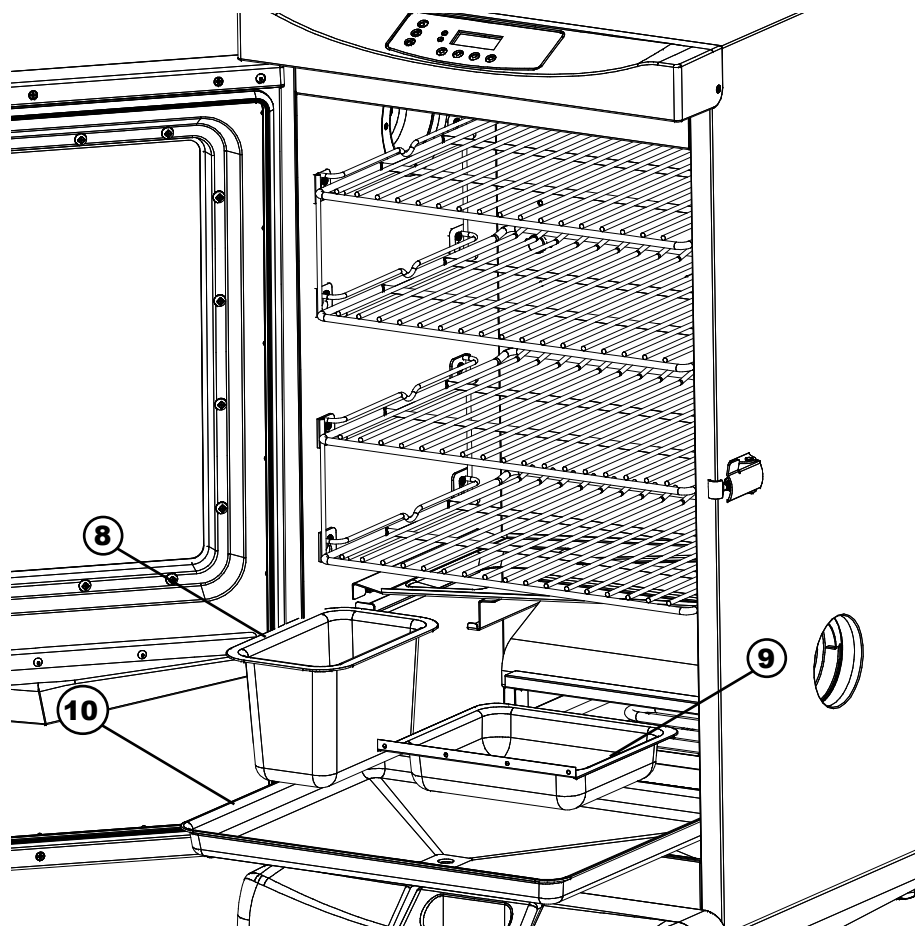

STEP 12

Place water bowl (8), wood chip tray (9), and drip pan (10) inside smoker as shown.

Insert wood chip loader (12) into side of smoker.

Assembly is complete.

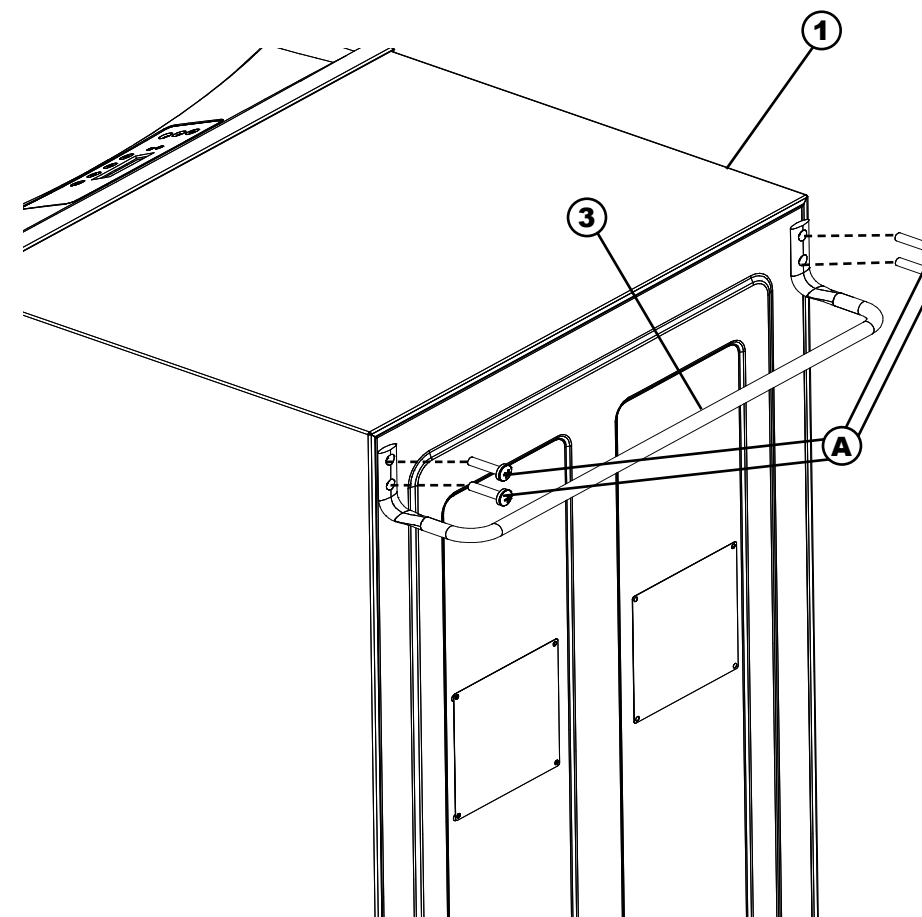

STEP 6

Carefully position smoker as shown.

Attach rear handle (3) to back of smoker body (1) using phillips screws (A) as shown.

Note: Do not lift unit by rear handle.

ASSEMBLY

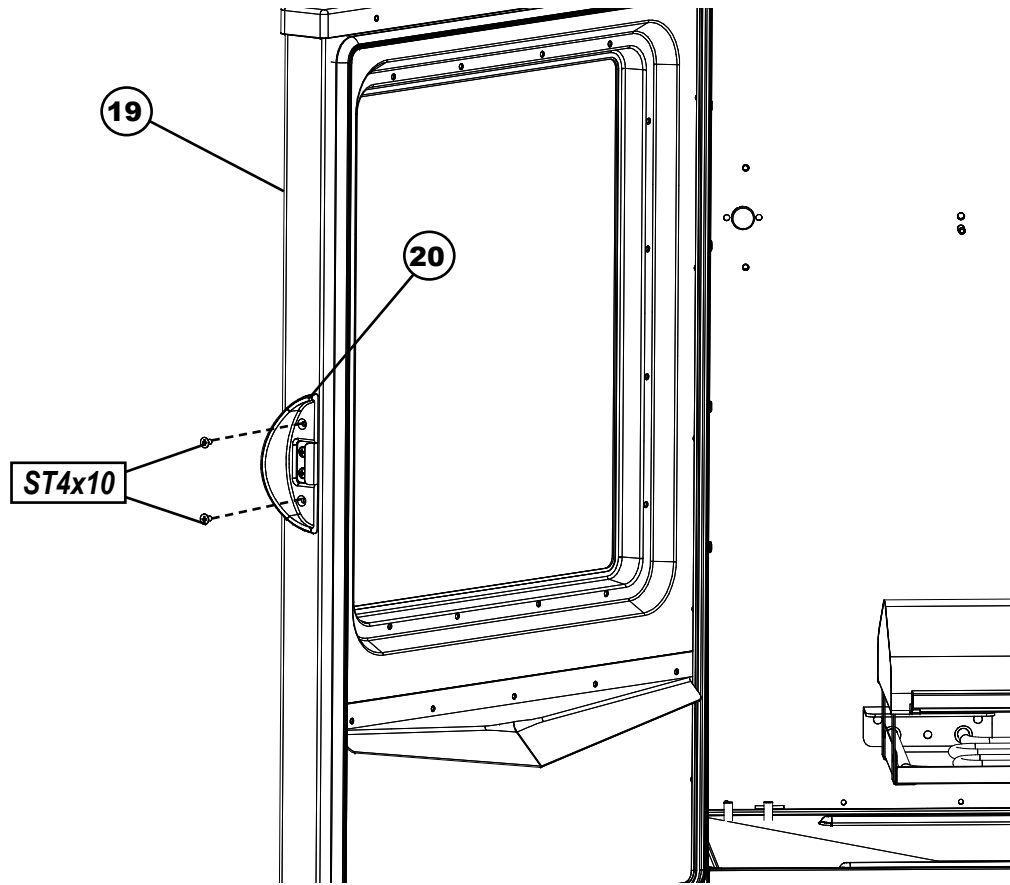

STEP 7
Position door handle (20) on door w/window (19) as shown. Secure using ST4x10 flat head screws.

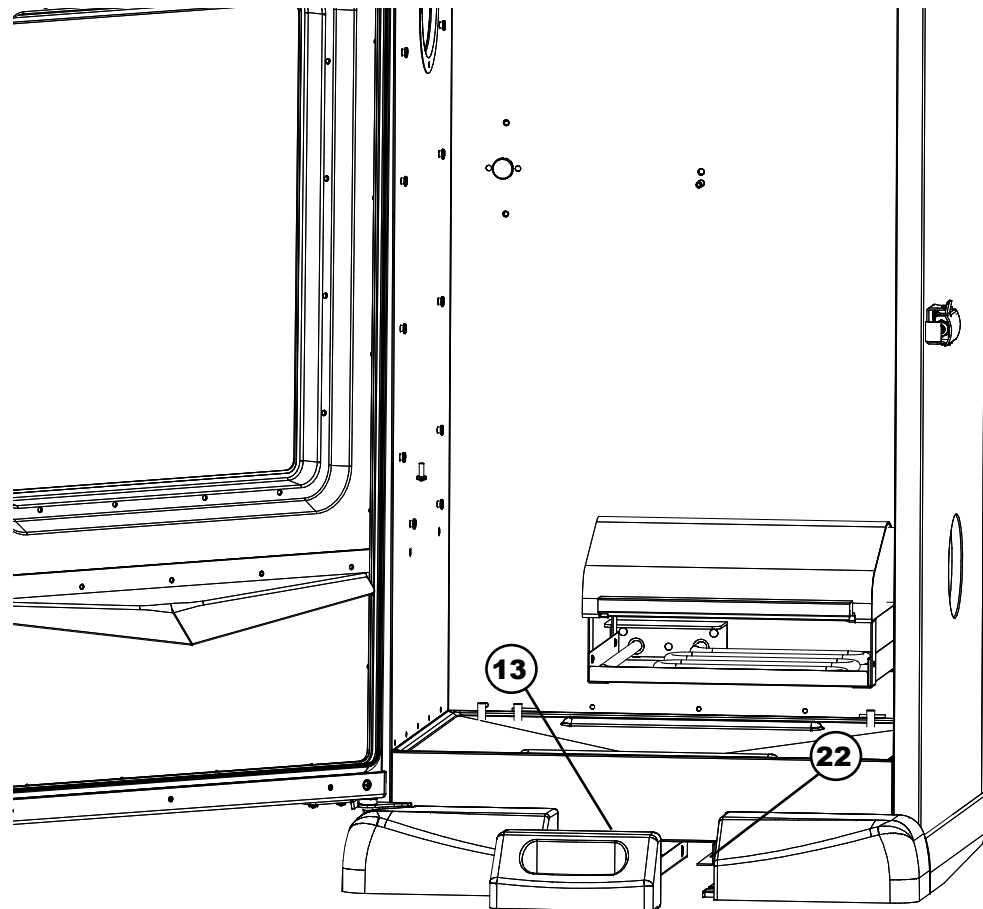

STEP 8
Slide grease tray (13) onto grease tray brackets (22).

ASSEMBLY

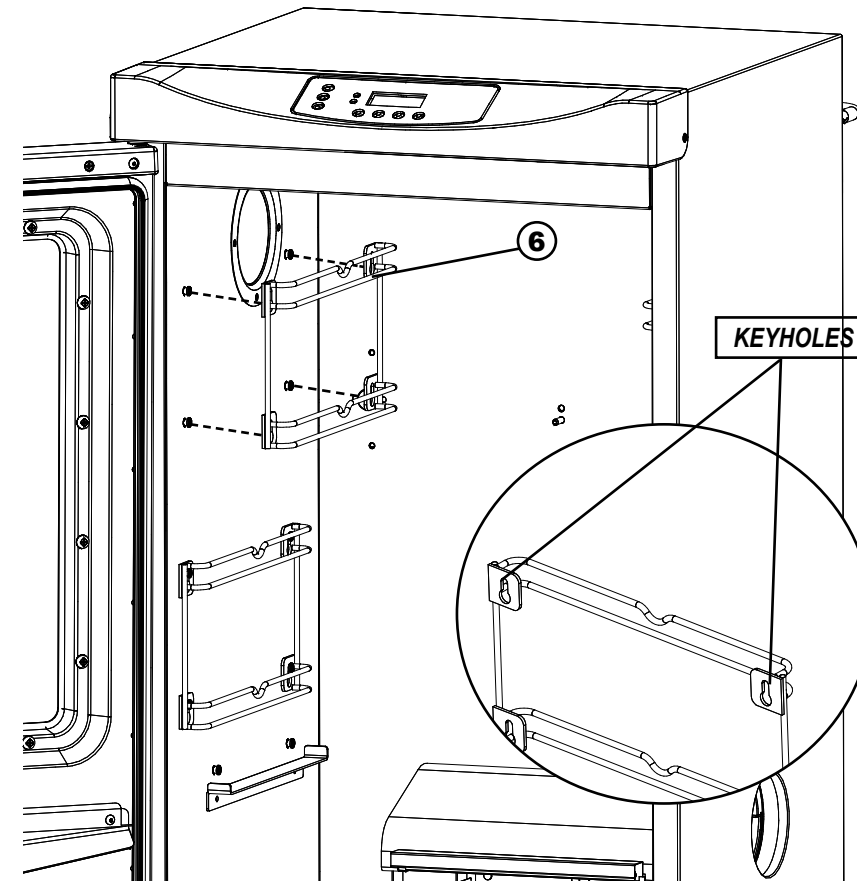

STEP 9
Align keyholes on grate supports (6) with studs on the inside of smoker body as shown. Press grate support down to secure in place.

Repeat step for remaining grate supports on both sides.

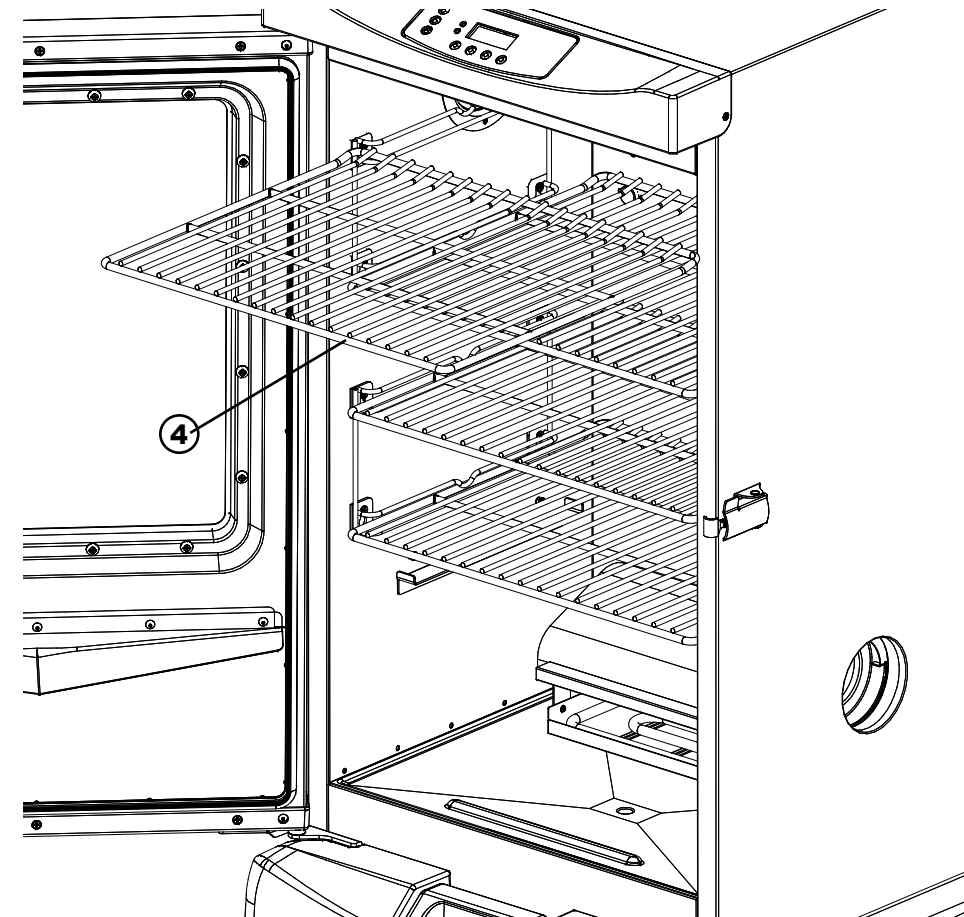

STEP 10
Place smoking racks (4) inside smoker as shown.