

grandhall

Operator's Manual

Liquid Propane Gas (LPG) Grill

Model XI08ALP

Natural Gas (NG) Grill

Model XI08ANG

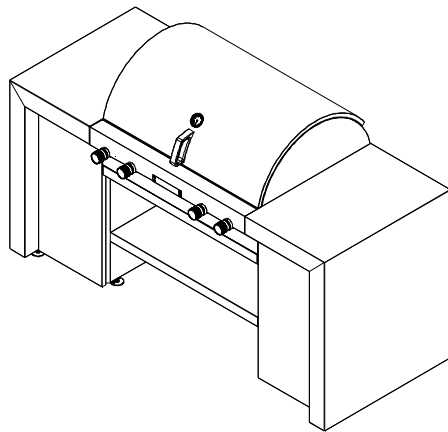

XI08ALP

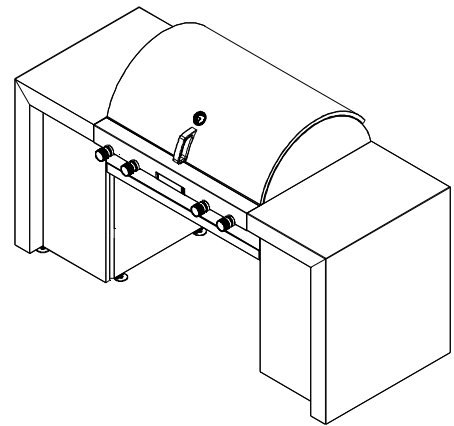

XI08ANG

FREE HELP FROM THE GRILL EXPERTS

At Grand Hall we're the experts on this product and trained to help you with:

- Y Assembly Questions
- Y Grill Operation
- Y Replacement of Damaged or Missing parts

visit www.grandhall.com or call:

1-877-934-7455

Monday - Friday 8:00am-4:30pm CST

IMPORTANT:

Y NOTE TO ASSEMBLER/INSTALLER:

Leave this manual with the consumer.

Y NOTE TO CONSUMER:

Keep this manual for future reference.

Y RECORD YOUR SERIAL # _____

(see silver CSA label on main body of grill)



WARNING



- Y Failure to comply with these instructions could result in a fire or explosion that could cause serious bodily injury, death or property damage.
- Y Whether this grill was assembled by you or someone else, you must read this entire manual before using your grill to ensure the grill is properly assembled, installed and maintained.
- Y **Use your grill at least 3 feet away from any wall or surface.** Use your grill at least **3 feet away** from combustible objects that can melt or catch fire such as vinyl or wood siding, fences and overhangs or sources of ignition including pilot lights on water heaters and live electrical appliances.
- Y **THIS GAS APPLIANCE IS DESIGNED FOR OUTDOOR USE ONLY.**
- Y **Never** use your gas grill in a garage, porch, shed, breezeway or any other enclosed area.
- Y **Never** obstruct the flow of ventilation air around your gas grill housing.
- Y **Never** disconnect the gas regulator or any gas fitting while your grill is lit. A lit grill can ignite leaking gas and cause a fire or explosion which could result in property damage, personal injury or death.

Table of Contents

Primary Safety Warnings	1-3
Pre-Assembly Instructions.....	3
Part Diagrams and Lists	4-7
Assembly Instructions.....	8-12
Use & Care Instructions:	
• Gas Safety and Leak Tests.....	13-16
• Natural Gas Connection.....	16
• Use & Care Instructions - LCD.....	17-18
• Lighting Instructions	19
• Troubleshooting	20
• Rotisserie Instruction.....	21-23
Cleaning and Maintenance	24
Cooking Guide.....	A1-A5
Frequently Asked Questions	A6-A7
Warranty Terms.....	Back Cover



Registered and unregistered Trademarks held by Grand Hall include the following:

Grand Hall and design®, DS Grill and design®, Crossray™ Lateral Infrared Burner Technology, Command Flame®, Smooth Start® Electronic Ignition System, Ceramic Savor Plates®, Sear-zzler®, Stainless Clad Therma-Core® Cooking Grids, Grand Café and design®, Grand Mark and design®, Grand Chef and design®, Grand Royale and design®, Globe Café and design®, Urban Café and design®, Smokeless Grill and design®.



Patents held by Grand Hall include the following:

The Crossray Burner System by Grand Hall is covered by Australian Patent No. 2006100635, Chinese Patent No. 960361, European Patent Pending, French Patent 0607231, German Patent No. 20 2006 012 212.5, U.K Patent GB2440714, and U.S. Patent 7,475,632.



©2008 Grand Hall. All Rights Reserved.

 **WARNING** 



- This appliance, when installed, must be electrically grounded in accordance with local codes or, in the absence of local codes, with the *National Electrical Code, ANSI/NFPA 70*, or the *Canadian Electrical Code, CSA C22.1*.
- Keep any electrical supply cord and the fuel supply hose away from any heated surfaces.

 **WARNING** 

1. Always keep the Grease/Water Tray 1/2 filled with water during operation. Failure to follow this could result in a grease fire that could cause serious bodily injury or property damage.
2. Handle this Grease/Water tray with a flame retardant BBQ mitt.

 **WARNING** 



1. Do not store or use gasoline or other flammable liquids or vapors in the vicinity of this or any other appliances.
2. An LP cylinder not connected for use shall not be stored in the vicinity of this or any other appliance.

 **WARNING** 

- LPG models must be used with Liquid Propane Gas and the regulator assembly supplied. Natural Gas models must be used with Natural Gas only. Any attempt to convert the grill from one fuel type to another is extremely hazardous and will void the warranty.
- Keep gas regulator hose away from hot grill surfaces and dripping grease. Avoid unnecessary twisting of hose. Visually inspect hose prior to each use for cuts, cracks, excessive wear or other damage. If the hose appears damaged do not use the gas grill. Call 1-877-934-7455 for a certified replacement hose.
- **California Proposition 65**
Combustion byproducts produced when using this product contain chemicals known to the State of California to cause cancer, birth defects, or other reproductive harm.

Brass components on the grill, such as hose fittings, propane cylinder valves (sold separately) and burner valve stems, contain lead which is known to the State of California to cause cancer, birth defects, or other reproductive harm.

- **Never use charcoal** or lighter fluid in this gas grill. Failure to comply with these instructions could result in a grease fire or explosion that could cause serious bodily injury, death or property damage.
- The Grease Tray must be visually inspected before each grill use. Remove any grease and wash Grease Tray with a mild soap and warm water solution. **Failure to comply with these instructions could result in a grease fire or explosion that could cause serious bodily injury, death or property damage.**

 **DANGER** 

If you smell gas:

1. Shut off gas to the appliance.
2. Extinguish any open flame.
3. Open lid.
4. If odor continues, keep away from the appliance and immediately call your gas supplier or your fire department.

Pre-Assembly Instructions For Your Safety

Congratulations on your selection of one of the finest outdoor kitchen appliances available. Your Grill is equipped with the unique Crossray Infrared Cooking System® by Grand Hall, which offers restaurant style grilling performance.

Infrared grilling technology cooks the food directly (and not the air around it) which offers many advantages over conventional grilling systems:

- MORE FLAVORFUL FOOD** as the intense heat sears the food and locks in the juices while also cooking it faster which usually means more succulence.
- FEWER FLAREUPS** as the higher infrared heat vaporizes more drippings which also adds natural flavoring to your food.
- MORE EFFICIENCY AND CONVENIENCE** as the higher heat means shorter cooking times, more fuel efficiency and easier year round grilling.

To begin your “restaurant quality” grilling, become familiar with all of the cooking elements of your Grand Hall Grill lighting and operating instructions.

IMPORTANT NOTE: Your infrared Grand Hall Grill is equipped with an innovative Grease/Water Tray that is designed to trap excess grease drippings but also to moisturize your food. It is important to keep this tray half-filled with water while grilling in order to get the best possible results.

WARNING: Grease and water can get very hot. Always handle the Grease/Water Tray with a flame retardant BBQ mitt. Before removing the Tray, always be sure that the grill has properly cooled. Be aware that the tray does contain water and grease and be extremely careful when removing the tray to prevent spillage. Failure to follow these instructions could cause serious bodily injury or property damage.

US Patented.: 7,475,632
Europe Patent Pending
Australia Patent No.: 2006100635
Germany Patent No.: 202006012212.5
France Patent No.: 0607231
UK Patent No.: GB2440714
China Patent No.: 960361

PRE-ASSEMBLY

Read and perform the following pre-assembly instructions:

- Tools Required for Assembly:**
 - protective work gloves
 - protective eyewear
 - #2, #3 Phillips head screwdriver
- You will need assistance from two people to handle the grill head and other large, heavy parts.
- Open Lid of shipping carton and remove top sheet of cardboard and packing materials. Lay cardboard sheet on floor and use as a work surface to protect floor and grill parts from scratches.
- You may slice the carton front corners with a utility knife to lay open the carton front panel. This allows you to raise the Lid and remove the components packed inside, making it easier to lift.
- Use the Hardware and Part Diagrams to ensure all items are included and free of damage.
- Do not assemble or operate the grill if it appears damaged. If there are damaged or missing parts when you unpack the shipping box or you have questions during the assembly process call
1-877-934-7455 M-F 8AM-4:30PM CST for assistance.

Grill Installation Codes

The installation must conform with local codes or, in the absence of local codes, with either the National Fuel Gas Code, ANSI Z223.1/NFPA 54, Natural Gas and Propane Installation Code, CSA B149.1, or Propane Storage and Handling Code, B149.2.

Hardware Pack Parts List for Models XI08ALP & XI08ANG

PART #	PART DESCRIPTION	QTY	PURPOSE OF PART
P06030003A	Hardware Pack	1	For use in assembly of Model XI08ALP
P06030007A	Hardware Pack	1	For use in assembly of Model XI08ANG
S125G04092	Phillips Head Screw, PT 1/4"x1-5/16"	16	Install Island Side Panel Bracket Assembly
S182G03062	Pan Head Screw 3/16"x3/8"	4	Install Rotisserie Motor
S164G04121	Socket Head Cap Screw 1/4"x3/4"	4	Install Island Side Panel Set
P05515006B	Wrench/M3	1	
S355G04001	Wing Nut 1/4"	4	
S411G05101	Plain Washer 5/16"	4	
P05515129C	Wrench	1	
S192G03062	Pan Head Screw 3/16"x3/8"	4	Install Island Side Panel Bracket to Island Side Panel Set
S165G04092	Hex Head Screw, PT 1/4"x2-1/16"	8	
S313G04062	Flange Nut 1/4"	8	
S182G04062	Pan Head Screw 1/4"x3/8"	4	Install Partition Panel Bracket to Island Decorative Panel (For XI08ALP Model)
S182G03062	Pan Head Screw 3/16"x3/8"	8	Install Island Decorative Panel
S162G04062	Hex Head Screw 1/4"x3/8"	4	Install Partition Panel (For XI08ALP Model)
P05515128Y	Wrench/M5	1	For use in removing/installing the replacement part for Lid

Hardware Pack Diagram for Models XI08ALP & XI08ANG

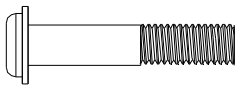

Phillips Head Screw,
PT 1/4"x1-5/16"
Qty. 16
Part # S125G04092

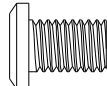

Pan Head Screw
1/4"x3/8"
Qty. 4 (LPG Model)
Part # S182G04062

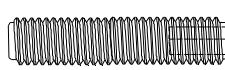

Socket Head Cap
Screw 1/4"x3/4"
Qty. 4
Part # S164G04121

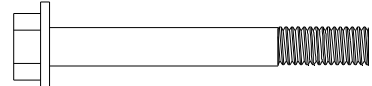

Hex Head Screw,
PT 1/4"x2-1/16"
Qty. 8
Part # S165G04092

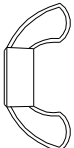

Wing Nut 1/4"
Qty. 4
Part # S355G04001



Plain Washer 5/16"
Qty. 4
Part # S411G05101

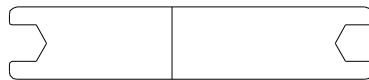

Wrench
Qty. 1
Part # P05515129C



Wrench/M3
Qty. 1
Part # P05515006B

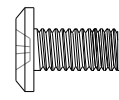

Pan Head Screw
3/16"x3/8"
Qty. 12
Part # S182G03062

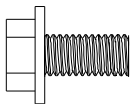

Hex Head Screws
1/4"x3/8"
Qty. 4 (LPG Model)
Part # S162G04062



Flange Nut 1/4"
Qty. 8
Part # S313G04062

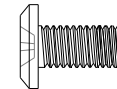
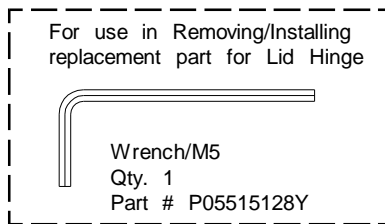

Pan Head Screw
3/16"x3/8"
Qty. 4
Part # S192G03062

Back Up Battery Parts List for Models XI08ALP & XI08ANG

PART #	PART DESCRIPTION	QTY	PURPOSE OF PART
P05301005Q	Spare Battery Box	1	Temporary Replacement for the Battery Pack/Rechargeable

Back Up Battery Diagram for Models XI08ALP & XI08ANG

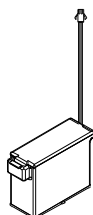

Spare Battery Box
Qty. 1
Part # P05301005Q

* One Battery/AA included in the Hardware Pack.

Parts Diagram for Models XI08ALP & XI08ANG

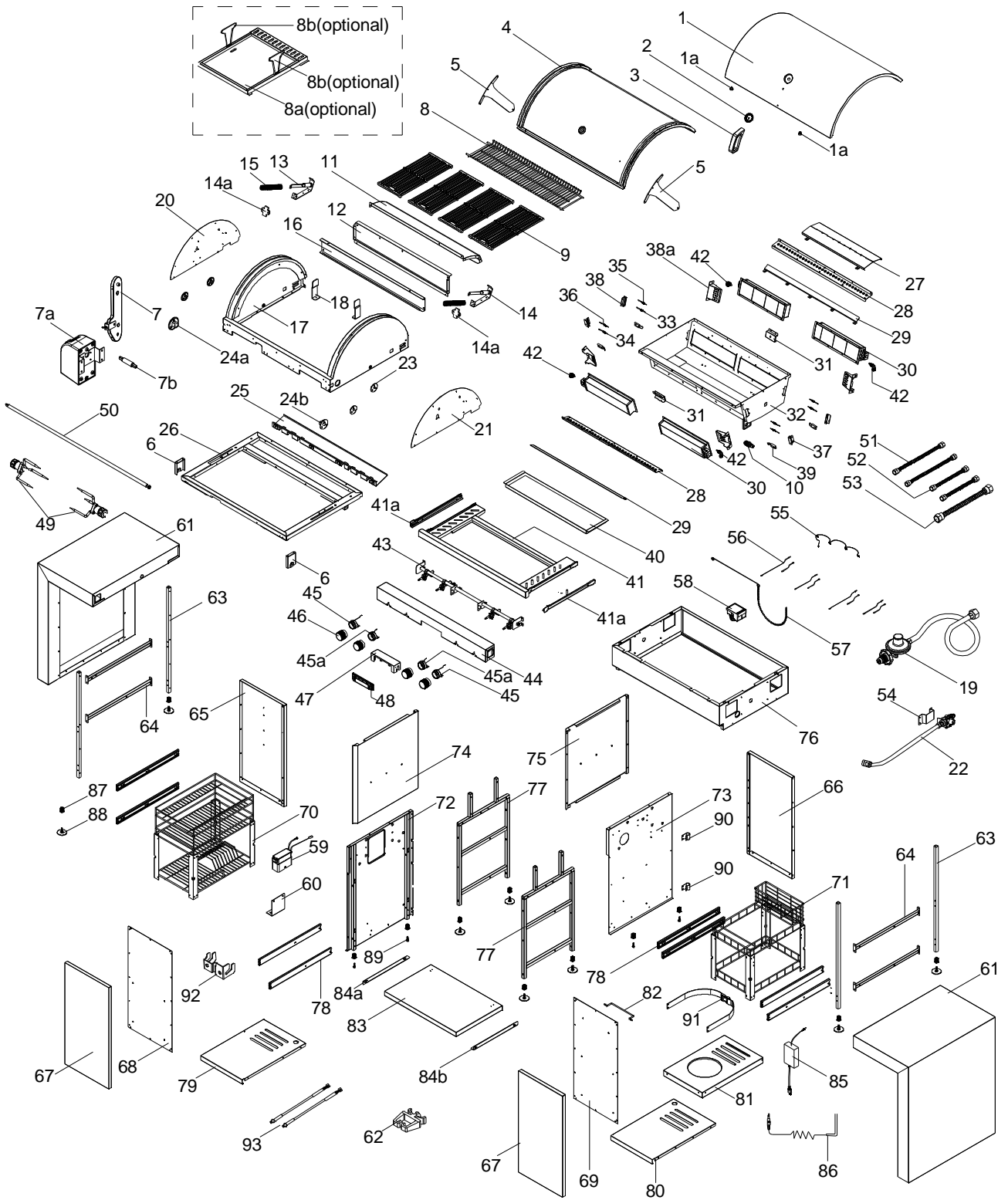

Parts List for Models XI08ALP & XI08ANG

KEY	DESCRIPTION	PART#	QTY
1	Lid Assembly Outer	P0014513A5	1
1a	Protective Pad	P05518018I	2
2	Temperature Gauge	P00601371A	1
3	Lid Handle	P00215034F	1
4	Lid Assembly Inner	P0014514E5	1
5	Lid Hinge	P05547004D	2
6	Lid Bracket	P033031165	2
7	Motor Transmission	P05378002B	1
7a	Motor/DC	P07102002A	1
7b	Gear Shaft	P05508201C	1
8	Cooking Rack/Secondary	P015160275	1
9	Cooking Grid	P01615035F	4
10	Gas Fitting	P03907008A	1
11	Bowl Panel, Rear/Upper	P007560265	1
12	Bowl Panel Fixed Shield, Rear/Upper	P0075603E5	1
13	Lid Spring Bracket Set, Left	P055510037	1
14	Lid Spring Bracket Set, Right	P055510047	1
14a	Protective Pad for Spring Bracket	P05518045I	2
15	Spring	P05504113N	2
16	Bowl Frame A Panel, Rear	P007259865	1
17	Bowl Frame A	P0071363S5	1
18	Bowl Frame A Bracket	P013180035	2
19	Regulator with Hose Assembly (LPG)	P03603050A	1
20	Bowl Frame Trim panel, Left	P0072091B5	1
21	Bowl Frame Trim panel, Right	P0072192B5	1
22	Regulator with Hose Assembly (NG)	P03628003A	1
23	Cooking Rack Bracket/Secondary	P01529001A	4
24a	Spit Bracket - Left	P05552001A	1
24b	Spit Bracket - Right	P05552002A	1
25	Control Panel Heat Shield	P0300917EB	1
26	Bowl Frame B	P013180055	1
27	Grease Tray Heat Shield	P069040485	1
28	Grease Shield, Lower	P069021245	2
29	Grease Shield, Upper	P069021255	2
30	Infrared Burner Assembly	P020050235	4
31	Cross Lighting Channel	P02212377A	2
32	Bowl Assembly	P0073957E5	1
33	Thermocouple for Gas Valve	P05305047A	2
34	Thermocouple for Gas Valve	P05305040D	2
35	Thermocouple for LED Light - Long	P05305048A	2
36	Thermocouple for LED Light - Short	P05305049A	2
37	Thermocouple Bracket	P03327058C	2
38	Thermocouple Bracket	P03327059C	2
38a	Thermocouple/Ignition Electrode Cover	P03343015C	4
39	Ignition Electrode	P02614055A	4
40	Grease Tray	P02717575B	1
41	Grease Tray Bracket Assembly	P03327073D	1
41a	Grease Tray Bracket Slide Set	P05516140M	1
42	Orifice (LPG)	P06539028A	4
	Orifice (NG)	P06539029A	4
43	Gas Valve/Manifold Assembly (LPG)	Y0060657	1
	Gas Valve/Manifold Assembly (NG)	Y0060658	1
44	Control Panel (LPG)	P02914208A	1
	Control Panel (NG)	P02914208F	1
45	Control Knob Seat with LED Light and Wire - Long	P03401444V	2
45a	Control Knob Seat with LED Light and Wire - Short	P03401454V	2
46	Control Knob	P03401424V	4
47	LCD Heat Insulating Spacer	P05357005D	1
48	LCD Assembly	P05357006B	1
49	Rot. Holding Fork	P05508198M	2
50	Rot. Spit	P05508199A	1
51	Connection Hose - Long	P03720001F	2

Parts List for Models XI08ALP & XI08ANG

KEY	DESCRIPTION	PART#	QTY
52	Connection Hose - Short	P03702035F	2
53	Connection Hose	P03715016F	1
54	NG Regulator Bracket (NG)	P033110415	1
55	Electric Wire, 4-Contact	P02627011A	1
56	Electric Wire Set	P02615150A	1
57	Lighting Stick	P05507140M	1
58	Electric Ignitor, 4-Port	P02502364C	1
59	Battery Pack/Rechargeable	P05301004B	1
60	Battery Bracket	P03348001D	1
61	Side Panel, Island	P011060495	2
62	Cord Holder	P055530013	1
63	Bracket/Island	P03334006D	4
64	Connection Bracket/Island	P03331017D	4
65	Panel, Left/Rear/Island	P07702107B	1
66	Panel, Right/Rear/Island	P07702108B	1
67	Door	P04304010B	2
68	Door Trim Panel, Left	P04316002B	1
69	Door Trim Panel, Right	P04316003B	1
70	Basket, Left	P05203009G	1
71	Basket, Right	P05203010G	1
72	Panel, Left/Island	P07617047B	1
73	Panel, Right/Island	P07618048B	1
74	Decorative Panel, Left/Island	P07605034B	1
75	Decorative Panel, Right/Island	P07606036B	1
76	Frame Assembly/Island	P01306027D	1
77	Side Panel Bracket Assembly/Island	P03334007D	2
78	Slide Set	P05516139M	4
79	Bottom Panel, Left/Island	P01001039D	1
80	Bottom Panel, Right/Island	P01001040D	1
81	Tank Tray	P04021010C	1
82	Towel Rack	P05212014A	1
83	Partition Panel (LPG)	P07515021B	1
84a	Partition Panel Bracket, Left (LPG)	P03303126D	1
84b	Partition Panel Bracket, Right (LPG)	P03303127D	1
85	Charger	P05384001B	1
86	Temperature Probe	P05385001B	1
87	End Cap, Leg	P06802008G	12
88	Level Adjuster A	P05322005B	8
89	Level Adjuster B	P05322006A	4
90	Hose Holder (NG)	P03338003D	2
91	Tank Fastening Strap (LPG)	P05314002V	1
92	Grate Handle Hook	P05514135G	1
93	Connection Wire Set	P02615170A	1
	Hardware Pack (LPG)	P06030003A	1
	Hardware Pack (NG)	P06030007A	1
	Operator's Manual	P80134004C	1

Optional Parts to Purchase for Models XI08ALP & XI08ANG

KEY	DESCRIPTION	PART#	QTY
8a	Griddle (optional)	P057050035	1
8b	Griddle Handle (optional)	P055151255	2
	Cover (optional)	P07007055A	1

For the repair or replacement parts you need:

Call 1-877-934-7455 M-F 8AM-4:30 PM CST

To obtain the correct replacement parts for your gas grill, please refer to the part numbers in this parts list. The following information is required to ensure you receive the correct parts:

1. Model and Serial Number (see CSA label on grill)
2. Part Number
3. Part Description
4. Quantity of parts needed

Important: Use only Grand Hall replacement parts. The use of any part that is not a Grand Hall replacement part can be dangerous and will also void your product warranty. Keep this Operator's Manual for convenient referral and for part replacement.

Assembly Instructions

CAUTION : To assemble this grill, you should obtain assistance from 2 people when handling the larger, heavier pieces.

1

Install Island Side Panel Bracket Assembly

- Lay a piece of cardboard on the ground (refer to Pre-Assembly Instructions). With the help of your assistant, remove the Grill Head from the box and put it on the cardboard. Reserve the box for next step.
- Remove all cooking components from the Grill Head. Raise the Grill Head and put it on top of the box as shown.
- Align the 8 holes on the Left Island Side Panel Bracket Assembly with the 8 holes on the Left Bowl Panel. Insert 8 Phillips Head Screws, PT 1/4"x1-5/16" and tighten securely.
- Repeat previous steps for the Right Island Side Bracket Assembly.
- Once the Bracket Assemblies have been securely installed, place the Grill Head with Bracket Assemblies onto the ground. Carefully remove the box from underneath the Grill Head.

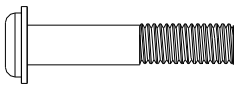

Phillips Head Screw,
PT 1/4"x1-5/16"
Qty. 16
Part # S125G04092

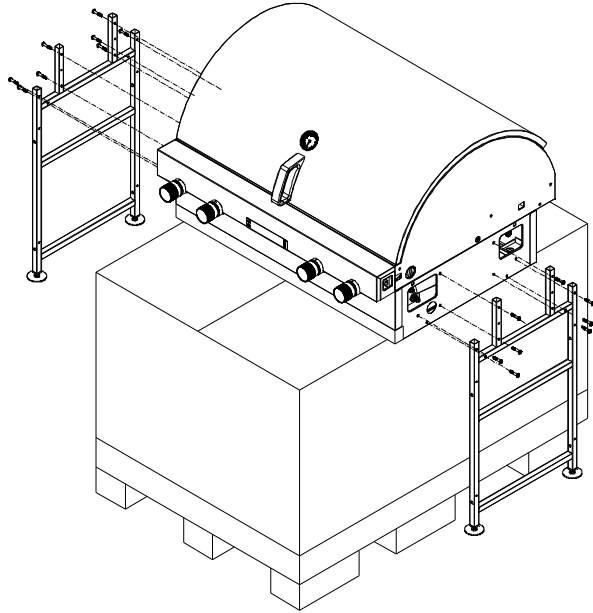

2

Install Rotisserie Motor

- Insert the Gear Shaft into the Rotisserie Motor as shown in diagram below.
- Insert the other end of the Gear Shaft with Motor into the hole on the Motor Transmission. Next, align the 4 holes on the Motor Bracket with the 4 holes on the Left Grill Bowl, then insert 4 Pan Head Screws 3/16"x3/8" and tighten as shown.

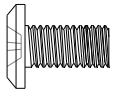

Pan Head Screw 3/16"x3/8"
Qty. 4
Part # S182G03062

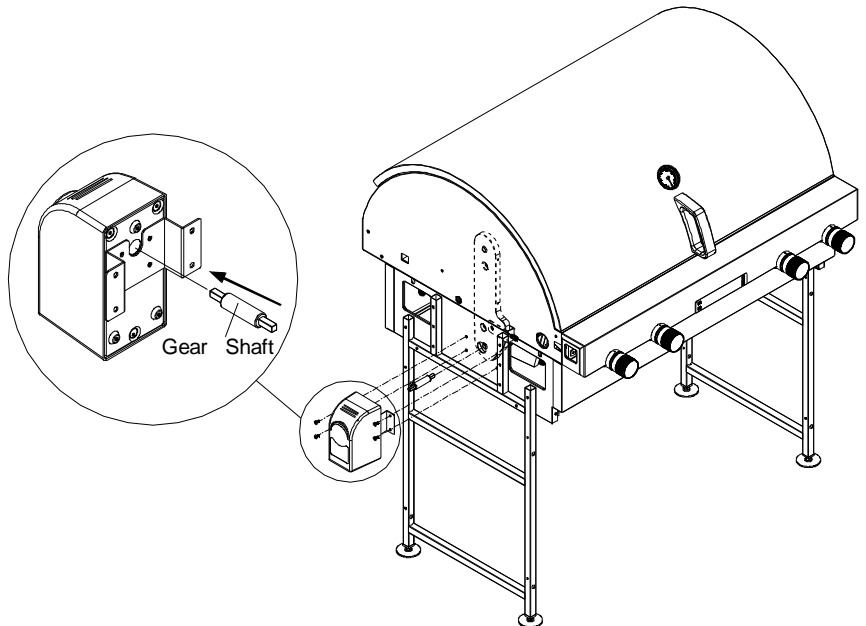

3

Install Island Side Panel Sets

- Insert 2 Socket Head Cap Screws 1/4"x3/4" into the Bowl Frame Trim Panel/Left. Tighten and secure using the Wrench/M3 as shown.
- With your assistants, lift the Side Panel, Left/Island and slide it towards the Left Island Side Bracket Assembly. Insert the 2 Electric Wires from the left side of the Control Panel into the holes on the Bowl Frame Trim Panel/Left and the Side Panel, Left/Island as shown. Align them by making sure the 2 Socket Head Caps in the Bowl Frame Panel go into the holes in the Island Side Panel Bracket Assembly.
- Open the Left Island Door. Find the ends of the 2 Socket Head Cap Screws (they should be where the Bowl Frame Trim Panel/Left and Side Panel, Left/Island meet). Install 1 Plain Washer 5/16" onto each Socket Head Cap Screw. Secure by installing 1 Wing Nut 1/4" on top of each washer.
- Repeat previous steps for the Side Panel Right/Island.
- If the Island Side Panels and the Grill are not level with each other, use the wrench to adjust the level adjusters on the bottom of the Bracket Assemblies.
 - Turn the adjusters clockwise to raise the height of the Grill.
 - Turn the adjusters counterclockwise to lower the height of the Grill.
 - FOR YOUR SAFETY DO NOT TILT your Grill at any time.

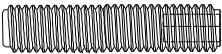

Socket Head Cap
Screw 1/4"x3/4"
Qty. 4
Part # S164G04121



Wrench/M3
Qty. 1
Part # P05515006B

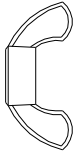

Wing Nut 1/4"
Qty. 4
Part # S355G04001



Plain Washer 5/16"
Qty. 4
Part # S411G05101



Wrench
Qty. 1
Part # P05515129C

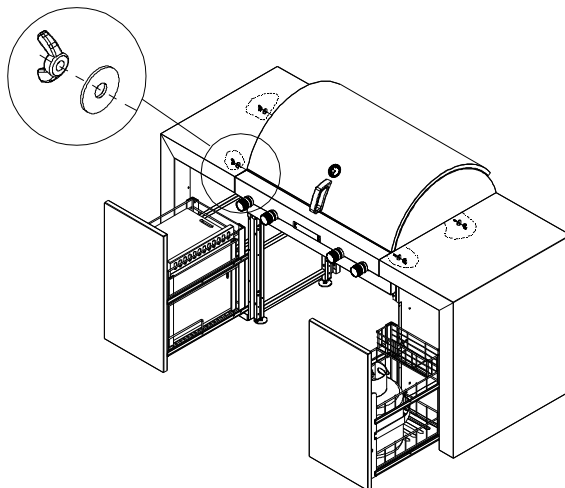
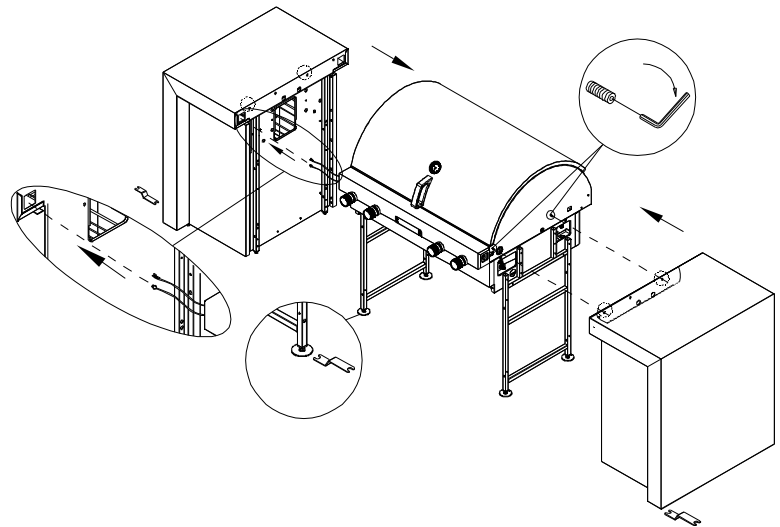

4 Install the Island Side Panel Bracket Assemblies onto the Island Side Panel Sets

- Align the 2 holes on the left Island Side Panel Bracket Assembly with the 2 holes on left Island Side Panel Set, insert 2 Pan Head Screws 3/16"x3/8" and tighten.
- Align the 4 holes on the Left Island Side Panel Bracket Assembly with the 4 holes on the Left Island Side Panel Set. Insert and install 4 Hex Head Screws PT 1/4"x2-1/16" Secure them by installing 4 Flange Nuts 1/4" as shown below.
- Repeat steps for the Right Island Side Panel Bracket Assembly.

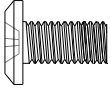

Pan Head Screw
3/16"x3/8"
Qty. 4
Part # S192G03062

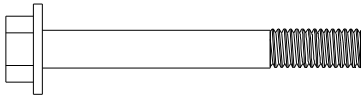

Hex Head Screw,
PT 1/4"x2-1/16"
Qty. 8
Part # S165G04092



Flange Nut 1/4"
Qty. 8
Part # S313G04062

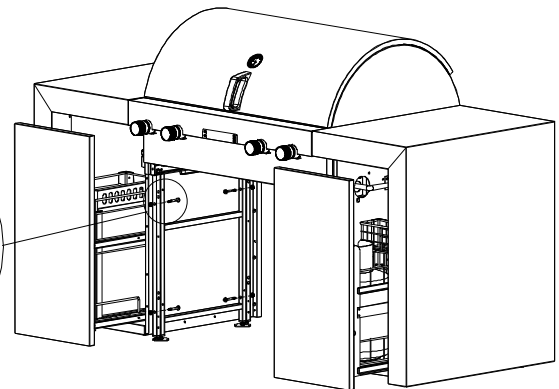
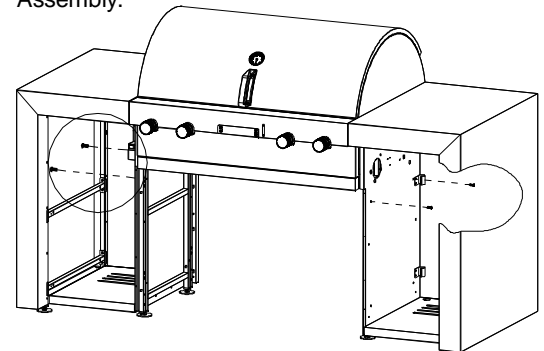
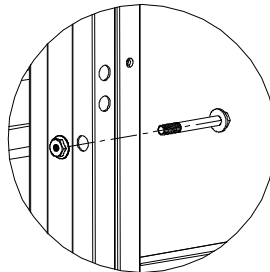

5 Install Partition Panel Bracket (For XI08ALP Model) and Island Decorative Panel

- Install the Left Partition Panel Bracket onto the Left Island Decorative Panel using 2 Pan Head Screws 1/4"x3/8" and tighten securely.
- Open the Left Island Door and insert the 4 pins on the Left Island Decorative Panel into the 4 holes on the rear of the Left Island Panel set. Push the Left Island Decorative Panel into position. Make sure the Decorative Panel is crossed over the Left Side Panel as shown in the diagram below.
- Align the 4 holes on the Left Island Decorative Panel with the 4 holes in the front of the Left Island Panel Set. Insert 4 Pan Head Screws 3/16"x3/8" and tighten securely.
- Repeat steps for installing the Right Partition Panel Bracket and the Right Island Decorative Panel.

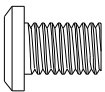

Pan Head Screw
1/4"x3/8"
Qty. 4 (LPG Model)
Part # S182G04062

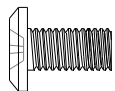

Pan Head Screw
3/16"x3/8"
Qty. 8
Part # S182G03062

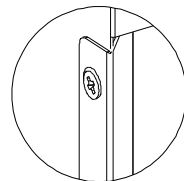

The Decorative Panel is crossed over the Side Panel

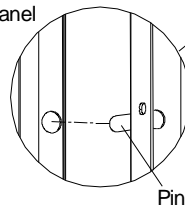

Pin

Left Island
Decorative
Panel

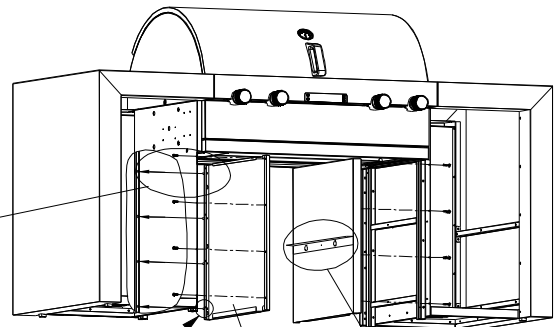
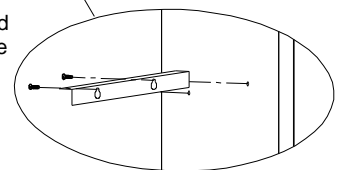

6-1 Install Battery Pack and Connect Electric Wires

- Put the Battery Pack into Battery Bracket as shown.
 - Thread the two Electric Wires through the Cord Holder as shown, then push Electric Wire Plug of the Battery Pack into the Electric Wire Socket for the LCD Display. Push Electric Wire Plug of the LCD Display into the Electric Wire Socket for the DC Motor.
- (Please refer to the Use and Care Instructions-LCD on pages 17-18 for more information).

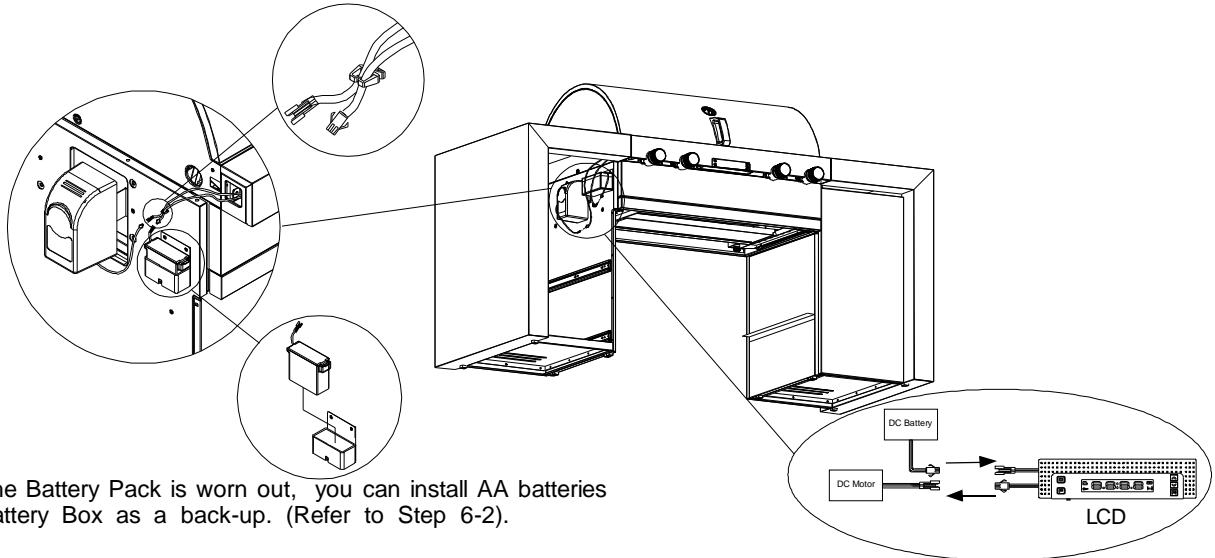

Note: If the Battery Pack is worn out, you can install AA batteries in the Battery Box as a back-up. (Refer to Step 6-2).

6-2 Install Back Up Batteries in the Battery Box. Connect Electric Wires.

- Unplug the Battery Box wire from the Electric Wire Socket for the LCD display. Next, take out the Battery Pack from the Battery Bracket.
- Open the cap for the Battery Box and put 8 AA batteries (sold separately) inside.
- Close the cap and then put the Battery Box into the Battery Bracket as shown in the diagram.
- Push Electric Wire Plug of the Battery Pack into the Electric Wire Socket for the LCD Display.

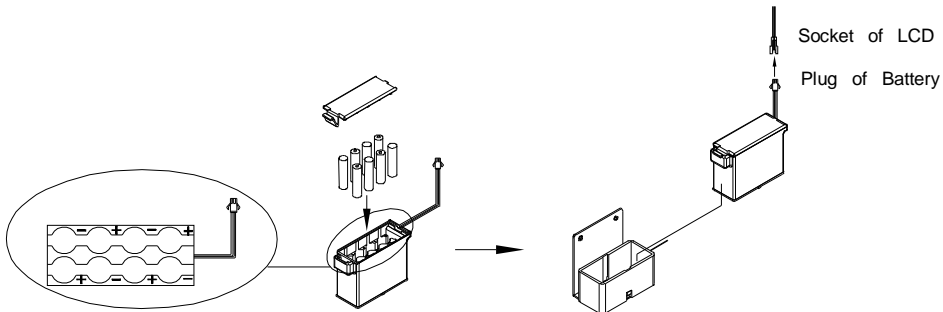

7 Install Partition Panel (For XI08ALP Model)

- Line up the fittings in the Partition Panel with the slots in the Partition Panel Brackets. From the underside of the Partition Panel, insert 4 Hex Head Screws 3/16"x3/8" and tighten securely (see diagram).

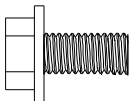

Hex Head Screws
1/4"x3/8"
Qty. 4 (LPG Model)
Part # S162G04062

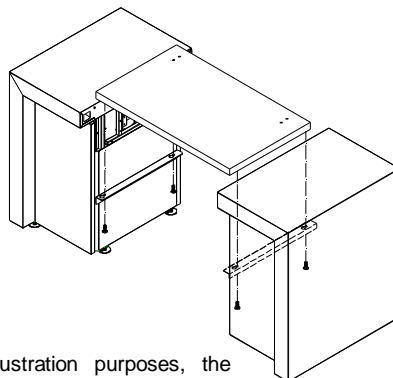

For illustration purposes, the Grill Head is not shown.

8 Install the Grease Tray Heat Shield and Grease Tray

- Place the 4 pins on the Grease Tray Heat Shield into the 4 Holes in the Grill Bowl as shown.
- Pull out the Grease Tray Bracket. Place the Grease Tray into the Grease Tray Bracket as shown. Push the Grease Tray Bracket back into position.

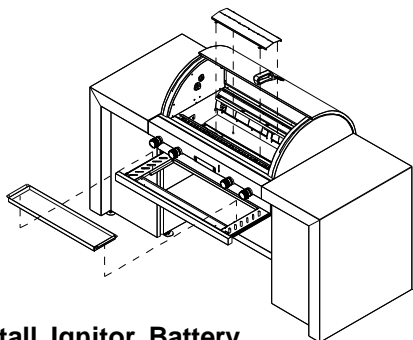

9 Install Ignitor Battery

- Remove Ignitor Cap from the bottom of the Island.
- Place AA battery into the Ignitor Slot with positive pole out.
- Position the Cap and Spring over the AA battery and tighten securely.

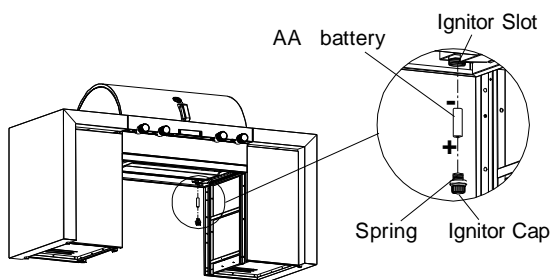

10 Main Burners Electrode Check Perform this Electrode Check with the assistance of another person

This test will ensure that the Spark Electrode Tips are correctly positioned so your grill lights easily and properly.

- Be sure all Control Knobs are set to "OFF" and open the Grill Lid.
- Have your assistant stand behind you to the right of the grill and look at both the front and rear burner locations of the grill bowl. **Never** put your face inside the Grill Bowl.
- Select any one of the Main Burner Control Knobs. Turn Control Knob to and push in. Have your assistant watch for a blue spark within the Ignition Electrode. Repeat process to test other burners.
- If no spark is seen, the Spark Gap needs to be adjusted as follows:
 - If the gap between the Spark Electrode tip and receiver is more than 1/8" wide, use needle nose pliers to gently squeeze the Ignition Electrode to narrow the gap. Try the Electrode Check again. If no "clicking" sound is heard:
 - AA Battery may be installed backwards.
 - Electric wires may be loose. Remove the AA battery and inspect the Ignitor Junction Box found underneath the Grill Head and reconnect any loose wires.

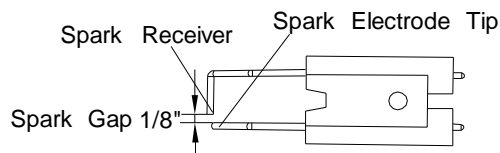

11 Install Cooking Components

- Place Cooking Grids on bowl ledge.
- Place the Secondary Cooking Rack into the slots on Grill Bowl Side Panels.
- Note: If you want to install the optional griddle, remove 2 cooking grids from the bowl ledge and install the griddle in their place. Store the remaining grids for later use. To Lift the Griddle: Insert the 2 griddle handles into the slots on opposite sides of the griddle. Once the handles have been installed, lift the griddle by the attached handles. Detach the handles from the griddle once you have finished moving the griddle and store them in the cabinet. (Refer to Figure 1).
- If the Griddle is not used, put it into the Left Basket as shown in Figure 1.

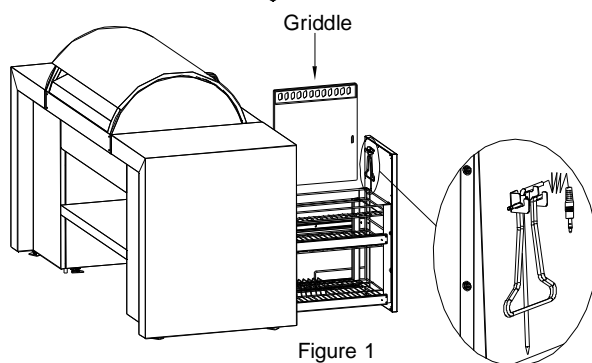
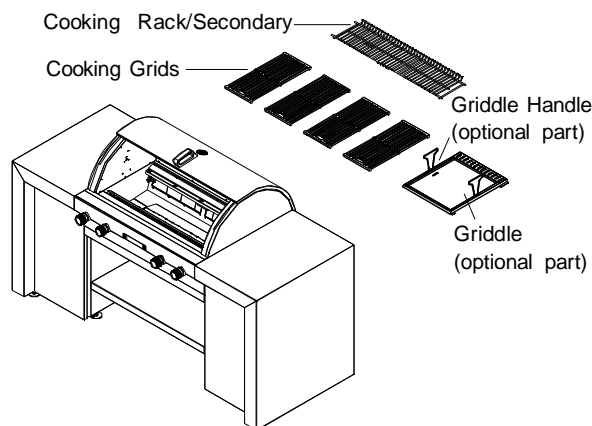

Final Grill Assembly Step

When you have finished assembling your grill, be sure that all screws are tightened for safe operation of your grill.

Before each use of the grill, the Grease/Water Tray should be filled approximately 1/2 full with water and fully seated under the grill bowl.

CAUTION: The Grease/Water Tray should be inspected before each grill use to be sure there is no excessive grease buildup. Clean the Tray frequently to eliminate grease build-up and to prevent grease fires.

LP Gas Tank Installation

CORRECT LP GAS TANK USE

- LP Gas models are designed for use with a standard 20 lb. Liquid Propane Gas (LP Gas) tank (sold separately). **Never** connect your gas grill to an LP Gas tank that exceeds this capacity. A tank of approximately 12 inches in diameter by 18-1/2 inches high is the maximum size LP Gas tank to use. **You must use an "OPD" gas tank which offers a listed Overfill Prevention Device.** This safety feature prevents the tank from being overfilled which can cause a malfunction of the LP Gas Tank, regulator, and/or grill.
- The LP Gas tank must be constructed and marked in accordance with the Specifications for LP-Gas Cylinders of the U.S. Department of Transportation (D.O.T.) or the National Standard of Canada, CAN/CSA-B339, Cylinders, Spheres and Tubes for Transportation of Dangerous Goods; and Commission, as applicable.
- The LP Gas tank must have a shutoff valve, terminating in an LP Gas supply tank valve outlet, that is compatible with a Type 1 tank connection device. The LP Gas tank must also have a safety relief device that has a direct connection with the vapor space of the tank.
- The tank supply system must be arranged for vapor withdrawal.
- The LP Gas tank must have a collar to protect the tank valve.
- Never** connect an unregulated LP gas tank to your gas grill. The gas regulator assembly supplied with your gas grill is adjusted to have an outlet pressure of 11" water column (W.C.) for connection to an LP gas tank. Only use the regulator and hose assembly supplied with your gas grill. **Replacement regulators and hose assemblies must be those specified by Grand Hall.**
- Have your LP Gas dealer check the relief valve after every filling to ensure it remains free of defects.
- Always keep LP Gas tank in upright position.
- Do not subject the LP Gas tank to excessive heat.
- Never store an LP Gas tank indoors. If you store your gas grill in the garage **always** disconnect the LP Gas tank first and store it safely outside.
- LP Gas tanks must be stored outdoors in a well-ventilated area and out of the reach of children.
- Disconnected LP Gas tanks must not be stored in a building, garage or any other enclosed area.
- The regulator and hose assembly can be seen after opening the door and must be inspected before each use of the grill. If your regulator and hose are damaged in any way, they must be replaced prior to using the grill again.
- Any attempt to convert the grill from one fuel type to another is extremely hazardous and will void the warranty.
- Never** light your gas grill with the lid closed or before checking to ensure the burners are fully seated over the gas valve orifices.

- Never** allow children to operate your grill. Do not allow children or pets to play near your grill. Always supervise children and pets if they are in the vicinity of the unit.
- Use of alcohol, prescription or non-prescription drugs can impair your ability to properly assemble and safely operate your grill.
- Keep fire extinguisher readily accessible. In the event of a oil/grease fire, do not attempt to extinguish with water. Use type B extinguisher or smother with dirt, sand or baking soda.
- In the event of rain, turn off the burners and gas supply. Wait for the grill to cool, and then place a cover on it.
- Use your grill on a level, stable surface in an area clear of combustible materials.
- Do not leave grill unattended when in use.
- Do not move the appliance when in use.
- Allow the grill to cool before moving or storing.
- Do not use your grill as a heater.
- This grill is not intended to be installed in or on recreational vehicles and/or boats.
- The grill is not intended for commercial use.
- Never use charcoal or lighter fluid in this gas grill.



WARNING



A. Do not store a spare LP-Gas tank under or near this appliance.

B. Never fill the tank beyond 80 percent full; and

C. If the information in "(a)" and "(b)" is not followed exactly, a fire causing death or serious injury may occur.



WARNING



- Use your grill at least 3 feet away from any wall or surface.
- Use your grill 3 feet away from any combustible objects that can melt or catch fire such as vinyl or wood siding, fences, overhangs (See Diagram Below), or any other sources of ignition; including pilot lights and live electrical appliances.
- Do not use your grill under any overhead combustible construction.
- Never use your gas grill in a garage, porch, shed, breezeway, or any other enclosed area.
- In windy conditions, always position the front of the grill to face oncoming wind to reduce heat and smoke blowing in your face, and to prevent potential hazards to yourself and the grill.

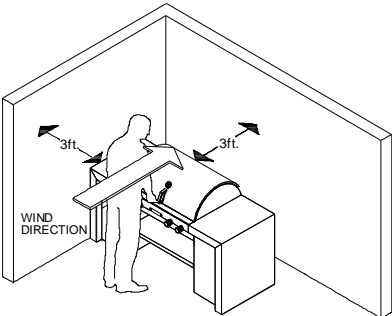

USE AND CARE INSTRUCTIONS

NOTE about LP Gas Tank Exchange Programs

- Many retailers that sell grills offer you the option of replacing your empty LP Gas tank through an exchange service. Use only those reputable exchange companies that inspect, precision fill, test, and certify their tanks. Exchange your tank only for an OPD safety feature-equipped tank as described in the LP Gas tank section of this Guide.
- Always keep new and exchanged LP Gas tanks in an upright position during use, transit or storage.
- Leak test new and exchanged LP Gas tanks BEFORE connecting one to your grill.

How to Leak Test your LP Gas Tank

For your safety:

- All leak tests must be repeated each time your LP Gas tank is exchanged or refilled.
 - When checking for gas leaks do not smoke.
 - Do not use an open flame to check for gas leaks.
 - Your grill must be leak tested outdoors in a well-ventilated area away from ignition sources such as gas fired or electrical appliances. During the leak test, keep your grill away from open flames or sparks.
 - Do not use household cleaning agents. Damage to gas assembly components can result.
- ☞ Use a clean paintbrush and a 50/50 mild soap and water solution.
- ☞ Brush soapy solution onto LP Gas tank in the areas indicated by the arrows. See diagram.
- ☞ If growing bubbles appear do not use or move the LP Gas tank. Call an LP Gas Supplier or your Fire Department.

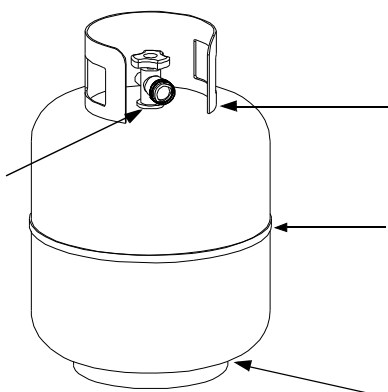

Secure a 20lb LP Gas Tank to Gas Grill

- Turn your LP Gas Tank Valve clockwise to the closed or OFF position.
- Slide the Tank Tray out of the cabinet until it is fully extended, then place the LP Gas tank into tank hole on bottom shelf.
- Install the Tank so the Tank Valve faces the left of the cabinet.
- Secure LP Gas Tank with the Fastening Strap.

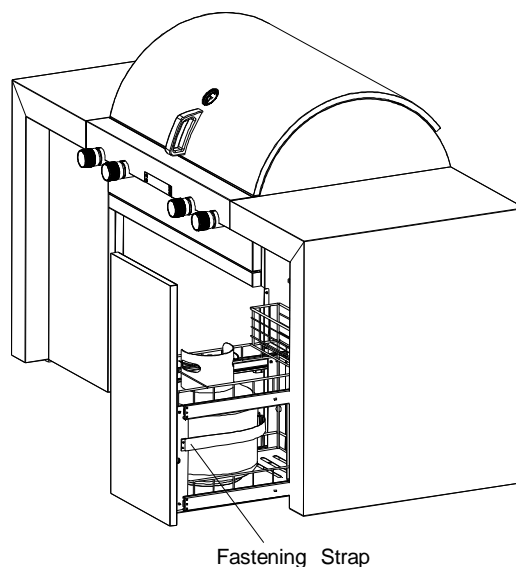

WARNING



If growing bubbles appear do not use or move the LP Gas tank. Contact an LP Gas Supplier or your fire department!

USE AND CARE INSTRUCTIONS

LP Gas Model only:

Connect Regulator with Hose to your LP Gas Tank

- Turn all Burner Valves to the OFF position.
- Inspect the valve connection port and regulator assembly for damage or debris. Remove any debris. Never use damaged or plugged equipment.
- Connect the regulator assembly to the tank valve and HAND TIGHTEN nut clockwise to a full stop. DO NOT use a wrench to tighten because it could damage the Quick Coupling Nut and result in a gas leak/fire hazard.
- Open the tank valve (counterclockwise) 1/4 to 1/2 of a full turn, and use a soapy water solution to check all connections for leaks before attempting to light your grill. See "**Check all connections for LP Gas Leaks**". If a leak is found, turn the tank valve off and do not use your grill until the leak is repaired.

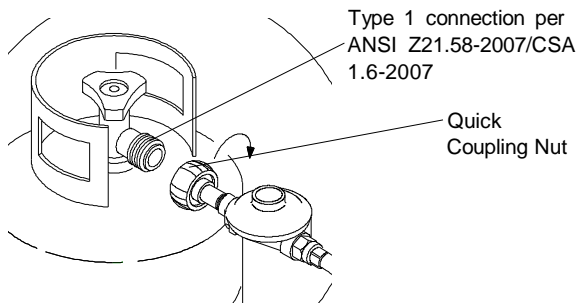

CAUTION: When the appliance is not in use the gas must be turned off at the tank. Place dust cap on cylinder valve outlet whenever the cylinder is not in use. Only install the type of dust cap on the cylinder valve outlet that is provided with the cylinder valve. Other types of caps or plugs may result in leakage of propane.

WARNING

If you have a gas leak that cannot be repaired by tightening the tank valve, turn off the gas at the source and disconnect fuel line from your grill. Call 1-877-934-7455 or your gas supplier for repair assistance.

WARNING

1. Do not store spare LP cylinder within 10 feet (3m) of this appliance.
2. Do not store or use gasoline or other flammable liquids and vapors within 25 feet (8m) of this appliance.
3. When cooking with oil/grease, do not allow the oil/grease to get hotter 350°F (177°C)
4. Do not leave oil/grease unattended.

Check all connections for LP Gas Leaks

Never test for leaks with an open flame. Prior to first use, at the beginning of each season, or every time your LP Gas tank is changed, you must check for gas leaks. Follow these three steps:

- Make a soap solution by mixing one part liquid detergent and one part water.
- Turn the grill Control Knobs to the full OFF position, then turn the gas ON at source.
- Apply the soap solution to all gas connections indicated by the arrows. See Diagram. If bubbles appear in the soap solution the connections are not properly sealed. Check each fitting and tighten or repair as necessary.

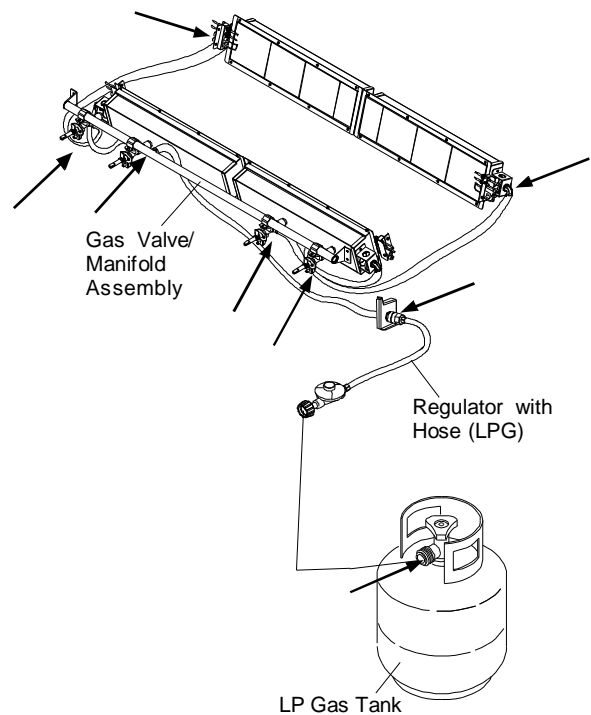

Disconnecting A Liquid Propane Gas (LPG) Tank From Your Grill

- Make sure the Burner Valves and LP Gas tank valve are off. (Turn clockwise to close.)
- Detach the hose and regulator assembly from the LP Gas tank valve by turning the Quick Coupling Nut counterclockwise. Do not use a wrench or any tools when turning the Quick Coupling Nut.

WARNING

Failure to read and follow the Use and Care Instructions could result in a fire or explosion that could cause serious bodily injury, death or property damage.

Natural Gas Connection

Natural Gas Model only: Connecting Natural Gas To Your Grill

- Connect the Swivel nut of the 12' Natural Gas Hose to the horizontal fitting of NG Regulator as shown in **Fig.1**. Connect the other hose end (male plug) to the gas supply line from your home. Read and follow the "Natural Gas Safety Instructions" below.

Natural Gas Safety Instructions

- Your natural gas grill is designed for use with natural gas (NG) only. The gas pressure Regulator supplied with this appliance **must** be installed and used on your grill. The unit and Regulator are set to operate with an outlet pressure of 4" W.C.
- Install a Shutoff Valve at the gas supply source outdoors at a point after the gas pipe exits the outside wall and before the quick-disconnect hose. Or install it at the point before the gas line piping enters the ground. See **Fig. 2**.
- Pipe sealing compound or pipe thread tape resistant to the action of natural gas must be used on all male pipe thread connections.
- Disconnect your gas grill from fuel source when the gas supply is being tested at high pressures. This gas grill and its individual shutoff valve must be disconnected from the gas supply pipe system during any pressure testing of that system at pressure in excess of 1/2 psi (3.5kpa).
- Turn off your gas grill when the gas supply is being tested at low pressures. The grill must be isolated from the gas supply pipe system by closing its individual manual shutoff valve during any pressure testing of the gas supply pipe system at pressures equal to or less than 1/2 psi (3.5kpa).

Fig.2

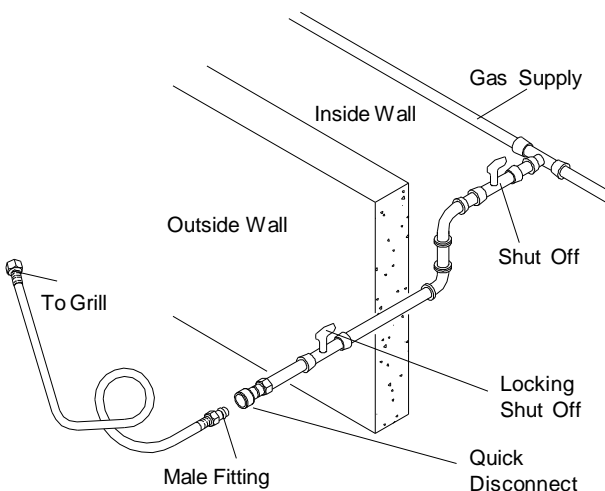
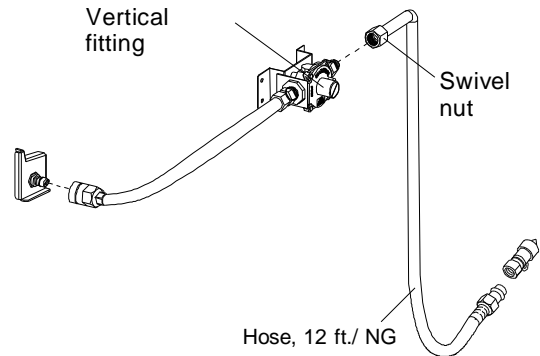

Fig.1



Check All Connections for Natural Gas Leaks

Never test for leaks with an open flame. Prior to first use and at the beginning of each season, you must check for gas leaks. Follow these three steps:

- Make a soap solution by mixing one part liquid detergent and one part water.
- Turn the grill Control Knobs to their full OFF positions. Next, turn the gas ON at the source.
- Apply the soap solution to all gas connections indicated by the arrows. See **Fig.3**. If bubbles appear in the soap solution the connections are not properly sealed. Check each fitting and tighten or repair as necessary.

Fig.3

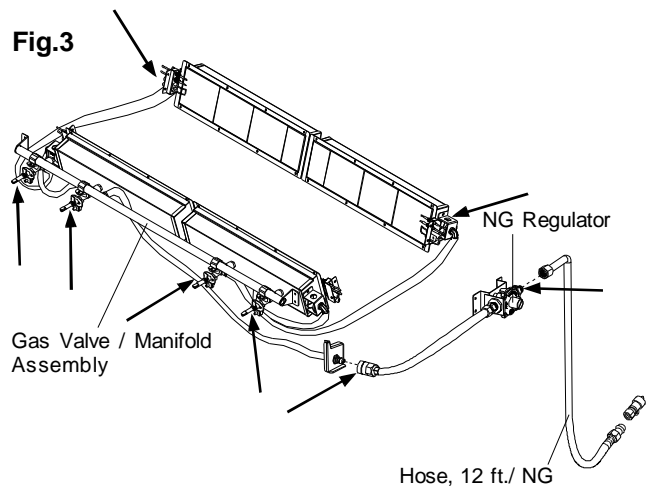

USE AND CARE INSTRUCTIONS - LCD



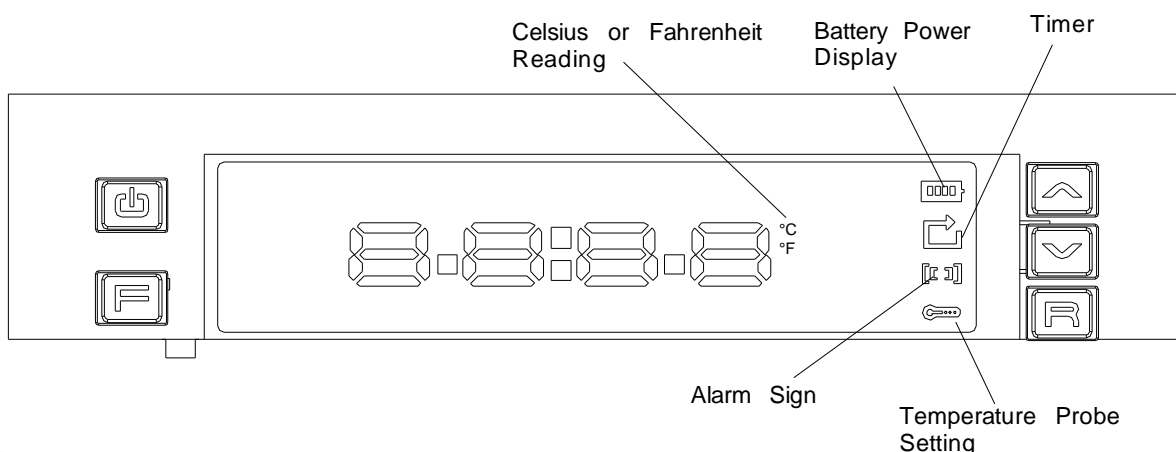

1 LCD Functions:

1. Cooking Timer (shows cooking time remaining)
2. Grill Temperature Display (indicates temperature of grill)
3. Flame Level Detector (indicates flame level)
4. Battery Power Display (indicates how much battery power is remaining)
5. Rotisserie Motor Controls





2 LCD Symbols:







3 Key Functions

-  This key turns the LCD Panel on/off.
-  This key allows you to navigate the LCD Panel's display settings. For example, you can use this key to display the temperature in Fahrenheit or Celsius, or set the display so that no temperature settings are shown.
-  This key is a directional key. It can be used to navigate the LCD display functions. (Ex: raising the temperature setting).
-  This key is a directional key. It can be used to navigate the LCD display functions. (Ex: lowering the temperature setting).
-  This key is for controlling the Rotisserie Motor. You can turn the motor on/off, and turn off the LCD display for the Rotisserie Motor.

4 How to Operate LCD Modes

Setting the Timer: Press  to reach the Timer mode. When  appears, press  or  to set the desired cooking time. (Note: The timer can only measure in minute units ranging from 0-200 minutes.) When you have selected your desired time, wait 3 seconds and your time will be saved.  will disappear from the LCD Panel, and the alarm will sound once. When the timer reaches the pre-set time, the alarm will sound for 10 seconds. If you press any key the alarm will stop. If you fail to press a key the alarm will continue to sound every minute for four minutes.

Setting Cooking Temperature for the Temperature Probe: Your temperature probe is used to measure the internal temperature of any meat that you are cooking. Your meat must reach a certain internal temperature before it can be considered fully cooked. Your temperature probe system allows you to preset and measure a cooking temperature. (Note: Do not leave the Temperature Probe inside a lit grill for an extended period of time-this can melt the wire. Check meat by placing the Probe in periodically, and taking it out after getting a reading. Do not leave the Probe inside the meat for the entire cooking duration. Do not use the Probe to measure the internal temperature of the grill.)

Press  to reach the mode. When °C or °F appears, press  or  to set your desired cooking temperature. (This temperature can be set from 0 to 250°F/120°C.) When you have selected your cooking temperature, wait 3 seconds and your cooking temperature will be saved. The  will disappear from the LCD Panel. When the set temperature is reached, the alarm will beep every 8 seconds until the meat's temperature is lower than the set temperature. At this point, you should remove your meat from the grill and check to see if it is fully cooked.

USE AND CARE INSTRUCTIONS - LCD

5 Using the Temperature Probe

Insert the plug of the Temperature Probe into the Temperature Control Outlet of the LCD Panel. When  appears, select whether you want the temperature displayed in Celsius or Fahrenheit.

Note: Do not measure the temperature of the burners by using this probe. Do not expose this probe to open flame. The highest temperature that the probe can measure is 250°F/120°C. Be cautious when using the probe to measure hot food. Use a flame retardant BBQ mitt to remove the probe from hot food. If the temperature probe is not in use, please place it on the Grate Handle Hook as shown in Figure 1 on page 12.

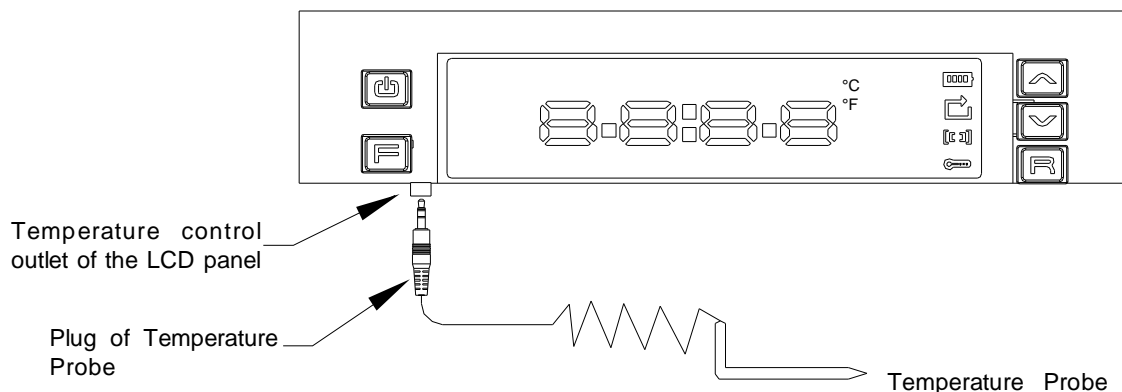

6 Flame Detector

This system detects the flame level within the grill, and whether the burners are lit. When a burner is fired up, the corresponding lamp on the knob seat will light up. If a burner is shut off or if the flame goes out, the corresponding lamp on the knob seat will turn off.

7 Notes

1. If the low-voltage  sign appears, you must charge the battery. If you do not charge the battery, this will affect the accuracy of the grill's temperature measuring instruments. The battery is rechargeable, but will need to be replaced depending on how frequently the grill is used.
2. Charge the battery for 24 hours prior to its first use. You will need to connect the charger as shown below.

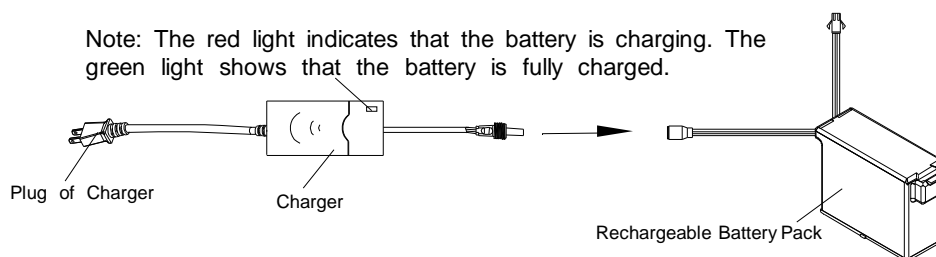

3. Disconnect the battery box from the charger, and disconnect the charger from the outlet when they are not in use. Do not leave the battery connected to the charger for extended periods of time; this will shorten the life of your rechargeable battery. Fully charged batteries will lose power if they are not used. Do not short-circuit the battery. Short circuiting the battery will damage both the battery and components connected to the battery.
4. Do not expose the battery to heat. Do not put batteries in the grill. Do not burn batteries. If you do any of these actions, your batteries will explode. Dispose of batteries according to your local codes.

USE AND CARE INSTRUCTIONS

Grill Lighting Instructions

1. Before each use, check all hoses for cracks, nicks, cuts, burns, or abrasions. If a hose is damaged in any way, do not use your grill before replacing the hose with an authorized part from the Parts List. Also make sure all gas supply connections are securely tightened.
2. Familiarize yourself with the safety and Use and Care instructions in this Guide. Do not smoke while lighting grill or checking gas supply connections.
3. Be sure the LP Gas tank is filled, and lock Casters to prevent movement during grill operation.
4. Open the Grill Lid.





WARNING



Failure to replace a faulty hose, secure gas supply connections or to open the Lid before proceeding to the Lighting Procedures could result in a fire or explosion that could cause serious bodily injury, death, or property damage.

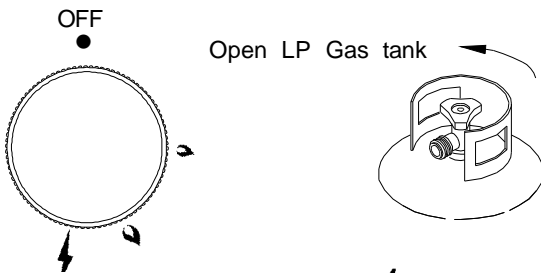

5. Set Control Knobs to OFF and open the LP Gas tank valve **SLOWLY 1/4 of a full turn**. For Natural Gas, open the Shut Off Valve at the source.

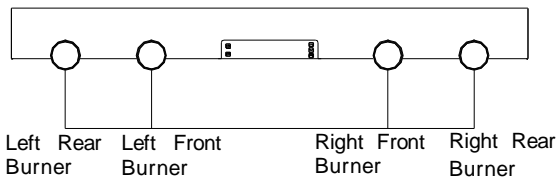
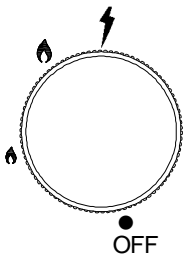

6. Push and turn the control knob to  and hold it in 3-5 seconds to ignite the Burner. Once the burner is ignited, continue to depress the knob and rotate to . Turn on the LCD panel, hold the knob until burner indicator light turns on then release it.



Infrared Burners

7. If ignition does not occur in 5 seconds, turn gas off at source and turn Control Knobs OFF. Wait at least 5 minutes for gas to clear, then retry. If your grill still fails to light turn the burner Control Knob(s) and gas source OFF and conduct a leak test of ALL gas connections and gas sources as explained in the Use and Care section of this guide. If no leaks are detected, wait 5 minutes for any gas to clear and repeat the lighting procedure.
8. If the burner indicator light does not work, check the LCD Battery Pack.
9. After one Burner is lit, turn the tank valve **SLOWLY** one more 1/4 of a turn. If other burners need to be lit, turn each other burner knob to  to light, then back to .

Manually Lighting Your Grill By Paper Match

To light your gas grill by match, insert a match into the Lighting Stick and follow steps 1 through 5 of the Grill Lighting Instructions. Then, light the match and place Lighting Stick through the Cooking Grid on the grill as shown below. Turn the nearest Control Knob to the  setting to release gas. The Burner should light immediately.

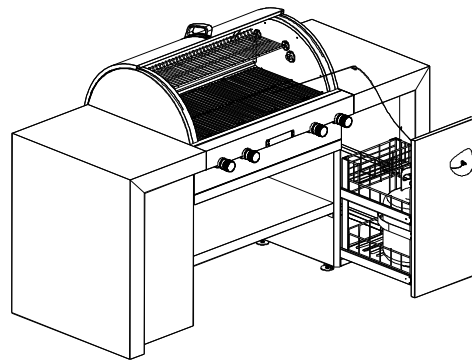

Note: Place the Lighting Stick inside the basket on the Right Cart when it is not in use.

USE AND CARE INSTRUCTIONS

Troubleshooting

If the grill fails to light :

1. Turn gas off at source and turn Control Knobs to OFF. Wait at least 5 minutes for gas to clear, then retry.
2. If your grill still fails to light, check gas supply and connections.
3. Repeat lighting procedure. If your grill still fails to operate, turn the gas off at source, turn the Control Knobs to OFF, then check for the following:

- Obstruction in gas line
Correction: Remove regulator hose from grill. Do not smoke! Open gas supply for one second to clear any obstruction from fuel line. Close off gas supply at source and reconnect fuel line to grill.
- Disconnected Electric Wires
Correction: Inspect the Electric Ignitor (see Parts List) found underneath the Grill Head. Connect loose Electric wires to Junction Box and try to light the grill.
- Weak AA battery
Correction: Remove the Ignitor Cap and replace the battery.
- If the grill still does not light you may need to purge air from the gas line or reset the regulator excess gas flow device. **Note:** This procedure should be done every time a new LP Gas tank is connected to your grill.



Never lean over the grill cooking area while lighting your gas grill. Keep your face and body a safe distance (at least 18 inches) from the front of the grill when lighting your grill by match.

To purge air from your gas line and/or reset the regulator excess gas flow device:

- Turn Control Knobs to the OFF position.
- Turn off the gas at the tank valve.
- Disconnect regulator from LP Gas tank. For Natural Gas, disconnect regulator from 12 ft. Natural Gas Hose.
- Let unit stand 5 minutes to allow air to purge from gas line.
- Reconnect regulator to the LP Gas tank. For Natural Gas reconnect regulator to 12 ft. Natural Gas Hose.
- Turn tank valve on SLOWLY 1/4 of a full turn. For Natural Gas, open Shut Off valve.
- Open the Grill Lid.
- Push and turn the Control Knob to ⚡ and hold it in 3-5 seconds to ignite the burner.



Should a FLASHBACK fire occur in or around the Burners, follow the instructions below. Failure to comply with these instructions could result in a fire or explosion that could cause serious bodily injury, death, or property damage.

- Y Shut off gas supply to the gas grill.
- Y Turn the Control Knobs to OFF position.
- Y Open the Grill Lid.
- Y Put out any flame with a Class B fire extinguisher.

USE AND CARE INSTRUCTIONS

CORRECT ROTISSERIE USE

Read all instructions before initial use.

IMPORTANT: When using electrical appliances, basic safety precautions should always be used.

The Rotisserie Motor is set for 12V, 5W DC.

The Rotisserie is for outdoor use only.

Do not equip your rotisserie with meat in excess of 12-15 pounds.

Do not let children operate or play nearby your grill or Rotisserie. Always supervise children and pets if they are in the vicinity of the unit.

Operating Rotisserie

The use of third part accessory attachments is not recommended by the manufacturer and may cause injuries. Do not use this Rotisserie other than for its intended use.

Do not immerse Motor in water or expose to rain, as this may result in an electrical shock.



Disconnect Rotisserie

After rotisserie cooking, the grill and rotisserie parts will be hot. Use a flame retardant BBQ mitt when handling the rotisserie.

Should a grease fire occur, turn the burners and gas off and leave the grill lid closed until the fire is out.

Store the Rotisserie indoors

When Rotisserie is not in use, store it indoors in a dry place.

 **WARNING** 



To protect against electrical shock, do not immerse electrical cord, plugs or motor in water or expose to rain. Protect electrical elements from burners, hot grill surfaces and grease.

 **CAUTION** 

To protect against electrical shock, connect only to properly Grounded Outlet.

ELECTRICAL EQUIPMENT USE

1. To protect against electric shock, do not immerse cord or plugs in water or other liquid.
2. Unplug from the outlet when not in use and before cleaning. Allow to cool before putting on or taking off parts.
3. Do not operate any cooking gas appliance with a damaged cord, plug, or if the appliance has been damaged in any manner or cannot be safely operated. Contact Grand Hall for replacement parts.
4. Do not let the cord hang over the edge of a table or touch hot surfaces.
5. Do not use an outdoor cooking gas appliance for any purposes other than its intended use.
6. When connecting, first connect plug to the outdoor cooking gas appliance then plug appliance into the outlet.
7. Use only a Ground Fault Interrupter (GFI) protected circuit with this outdoor cooking gas appliance.
8. Never remove the grounding plug or use with an adapter of 2 prongs.
9. Use only extension cords with a 3 prong grounding plug, rated for the power of the equipment, and approved for outdoor use with a W-A marking.

 **WARNING** 

This appliance, when installed, must be electrically grounded in accordance with local codes or, in the absence of local codes, with the *National Electrical Code, ANSI/NFPA 70*, or the *Canadian Electrical Code, CSA C22.1*.

Keep any electrical supply cord and the fuel supply hose away from any heated surface.

Rotisserie Instructions

1. Remove all components from the carton.
2. Slide a Holding Fork onto each end of the Rotisserie Spit. Adjust spacing between Holding Forks to accommodate your food, then turn clockwise until the screw stops.

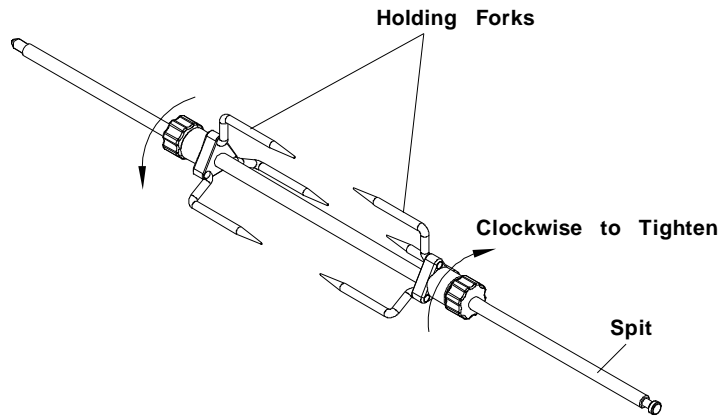

Note: In order to avoid damaging the holding fork, do not tighten unless it is assembled on the spit rod.



3. Refer to Motor installation steps on page 8. Be sure the Motor attaches to the Motor transmission with the electrical cord facing down.

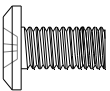

Pan Head Screw 3/16"x3/8"
Qty. 4
Part # S182G03062

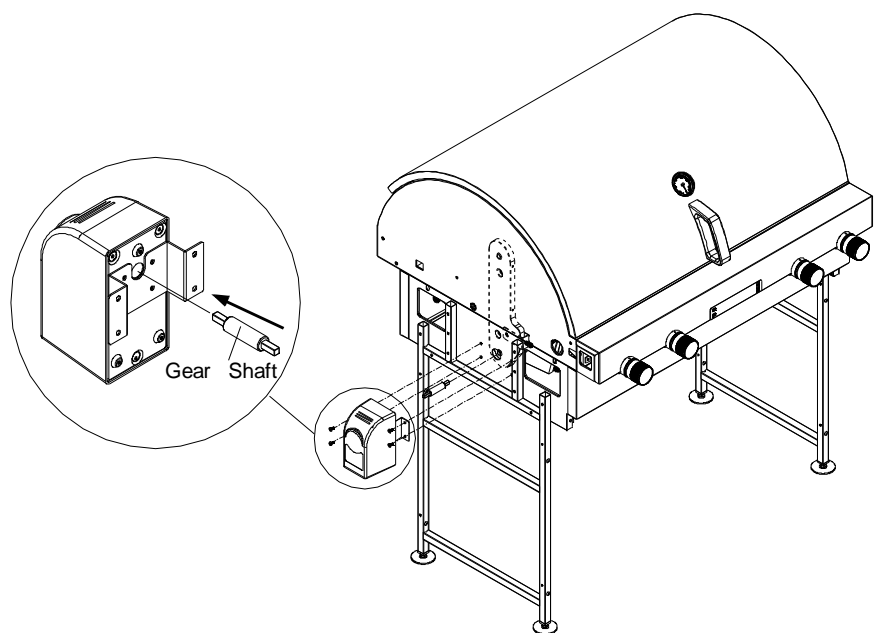

4. Insert the left side of the assembled Rotisserie Spit into the Motor Transmission. Next insert the right side of the Spit into the hole on the Right Bowl Frame Panel. (See diagram below.)

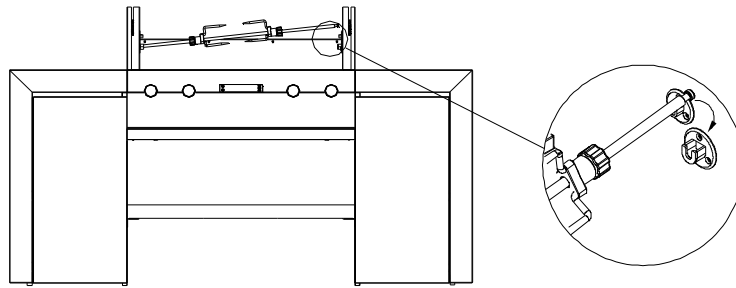

5. Make sure that you have completed installation step 6 on page 11 before testing the rotisserie or turning it on.

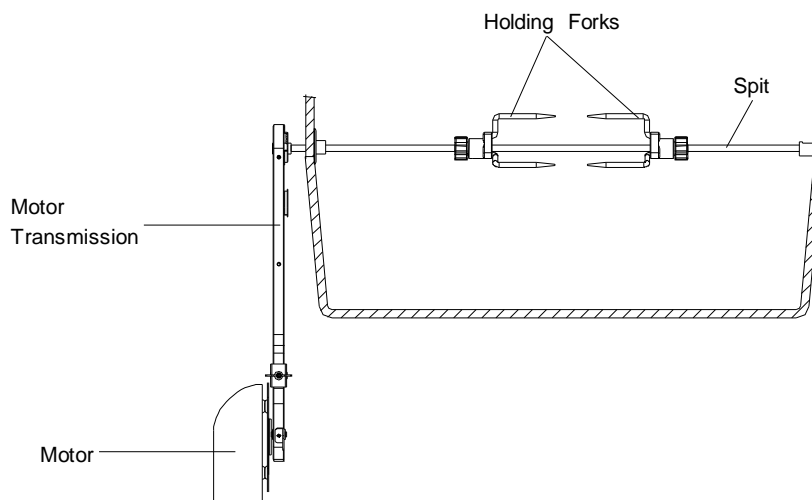

BEFORE rotisserie cooking, you will need to remove the Cooking Grids and possibly the Griddle from your grill.

6. If the Rotisserie is not used, you can put the Rotisserie Spit in the Grease Tray Bracket and put the Holding Forks in the Right Basket as shown.

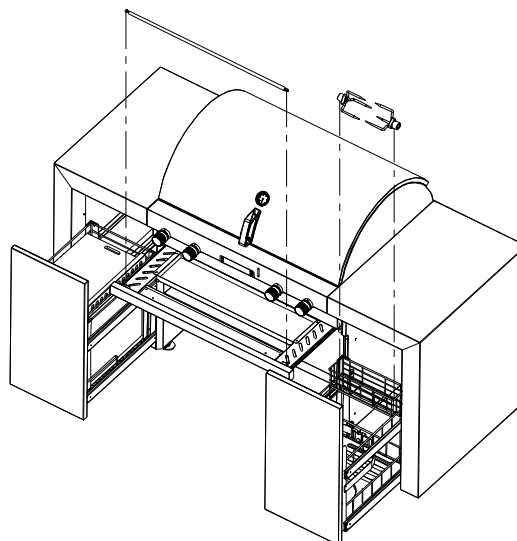

CLEANING AND MAINTENANCE

Proper care and maintenance will keep your grill in top operating condition and prolong its life. Follow these cleaning procedures on a timely basis and your grill will stay clean and operate with minimum effort.

CAUTION: Be sure your grill is OFF and cool before cleaning.

Cleaning The Cooking Grids

- Before initial use and periodically thereafter, wash your Cooking Grids in a mild soap and warm water solution. You can use a wash cloth or vegetable brush to clean your Cooking Grids.

Cleaning the Grease Tray

- To reduce the chance of fire, the Grease Tray should be visually inspected before each grill use. Remove any grease and wash Grease Tray with a mild soap and warm water solution.

Cleaning the Inside of the Grill Lid

- Grease can build up on the inside of the Grill lid over time. This grease can drip onto your deck or patio when the lid is opened. Visually inspect the inside of the Grill Lid before each grill use. Remove any grease and wash with a mild soap and warm water solution.

Routine Cleaning of The Grill Interior

- Burning-off excess food after every cookout will keep it ready for instant use. However, at least every 3 months you must give the entire grill a thorough cleaning to minimize your risk of grease fire and keep the grill in top shape. Follow these steps:

1. Turn all Burner Knobs to the full OFF position.
2. Turn the LP gas tank valve to the full OFF position.
3. Disconnect the regulator from the gas tank. Inspect the hose for cracking, cuts or any other damage, and replace as necessary. Refer to the Parts List in this Operator's Manual.
4. Remove and clean the Cooking Grids and Secondary Cooking Rack.
5. Brush the inside and bottom of the grill with a fiber pad or nylon brush and wash with a mild soap and warm water solution. Rinse thoroughly and let dry.
6. Check each Spark Electrode, adjusting as needed. The space between the Spark Electrode Tip and Spark Receiver should be approximately 1/8" .
7. Replace the Cooking Grids and Secondary Cooking Rack.
8. Reconnect the gas source and observe the Burner flame for correct operation.

Cleaning Exterior Painted Surfaces:



- Before initial use, and periodically thereafter, we suggest you wash your grill using a mild soap and warm water solution. You can use a wash cloth or sponge for this process. Do not use a stiff wire or brass brush. These will scratch stainless steel and chip painted surfaces during the cleaning process.

Cleaning Exterior Stainless Steel Surfaces:

- Routine care and maintenance is required to preserve the appearance and corrosion resistance of stainless steel. The fact is stainless steel can corrode, rust and discolor under certain conditions. Rust is caused when regular steel particles in the atmosphere become attached to the stainless steel surface. Steel particles can also become attached to your grill if you use steel wool or stiff wire brushes to clean the grill instead of non-abrasive cloth, sponge or nylon cleaning tools. In coastal areas rust pits can develop on stainless surfaces that cannot be fully removed. Bleach and other chlorine based solutions used for household and pool cleaning can also cause corrosion to stainless steel. Weathering, extreme heat, smoke from cooking and machine oils used in the manufacturing process of stainless steel can cause stainless steel to turn tan in color. Although there are many factors which can affect the surface appearance of stainless steel, they do not affect the integrity of the steel or the performance of the grill.

- To help maintain the finish of stainless steel follow these cleaning tips for the best results:

1. After every use (after your grill has cooled down), wipe stainless surfaces with a soft, soapy cloth or sponge then rinse with water. Be sure to remove all food particles, sauces or marinades from stainless steel because these can be highly acidic and damaging to stainless surfaces.
2. Never use abrasive cleaners, scrubbers or stiff wire brushes of any type on your grill.
3. Use a heat resistant Stainless Steel Cleaner and rub or wipe in the direction of the stainless steel grain or polish lines. Do not polish against the grain.

 **WARNING** 

Failure to comply with these instructions could result in a fire or explosion that could cause serious bodily injury, death or property damage.

Keep grill area clear and free from combustible materials, gasoline and other flammable vapors and liquids.

Do not obstruct the flow of air for combustion and ventilation.

Keep the ventilation openings of the tank enclosure cabinet free and clear of debris.

Visually check burner flames occasionally to ensure proper flame pattern as shown below.

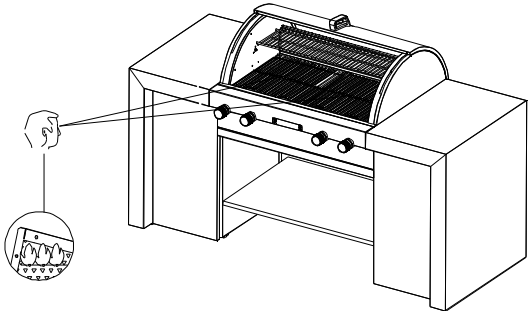

MAGNIFIED VIEW OF INFRARED BURNER FLAME THROUGH OPEN LID.

 **WARNING** 

Do not leave the grill unattended during burn off. Empty and clean the grease tray before doing burn-off.

Infrared Grill Cooking Instructions

Burn-Off

- Before cooking on your gas grill for the first time, you should "burn off" the grill to eliminate any odor or foreign matter. Ignite the burners, lower the Lid, and operate grill on 🔥 setting for 3 to 5 minutes.

CAUTION: Infrared cooking times will be much shorter than traditional grilling so never operate this appliance unattended.

Preheating

- To preheat, light your grill on 🔥, lower the Lid and follow this timetable.
- ℥ For searing and high temperature cooking, preheat grill 3 to 5 minutes.
- ℥ For low temperature cooking, preheat grill 3 minutes.
- ℥ To slow cook, preheating is not necessary.

Control Knob Settings

- High setting:** The 🔥 Control Knob setting should only be used to pre-heat your grill the first 3-5 minutes, for searing foods and for burning food residue off the grill for 3-5 minutes after cooking is complete.

CAUTION: Infrared cooking times will be much shorter than traditional grilling so never operate this appliance unattended.

- Low setting 🔥:** Most recipes specify the low setting for baking, roasting, rotisserie cooking and grilling delicate foods such as fish, vegetables and bread.

An Important Note About Infrared Heat Settings

- The suggested heat settings and cooking times shown in the following pages are approximate. Unlike the controlled environment inside your kitchen, variables including outside temperatures, direction and conditions of wind, as well as grill location will affect your grill's heat distribution. Because these conditions vary, and no two backyards are alike, we offer these tips as general guidelines for your reference. We recommend you monitor your grill closely and rotate foods often to prevent overcooking and ensure the most delicious results every time.
- ℥ The heat from the front and rear infrared burners overlap in the mid section of each cooking grid. This area offers the most intense heat for quickly locking in the natural juices and flavor of poultry and meats.
- ℥ The Secondary Cooking Rack offers less intense heat for preparing breads and firm vegetables like potatoes and corn.
- ℥ Infrared heat sears the food surface and cooks from the inside out. Infrared heat does not cook through aluminum foil and reflective pans. For roasting and baking you'll find a cast-iron pan works beautifully as it absorbs and conducts the infrared heat very well.

Direct Cooking

- The direct cooking method can be used with the food placed on the mid section of each cooking grid where the infrared heat is most intense. **Direct Cooking requires the Grill Lid to be open.** This method is ideal for searing and grilling as well as deep frying in a cast-iron pan or stir-frying in a steel wok.

Indirect Cooking

- To cook **indirectly**, the food should be placed on the left or right side of your grill (or Secondary Rack) with the Burners lit on the opposite side. Rotate the food as needed to ensure even browning. This is the slow cooking method. A faster indirect method is to place your food in an optional cast-iron cooking pan and place it in the center of the grill with all burners on LOW. Be sure to add liquid if using a pan to keep food moist. If higher heat is desired, turn Left Front (LF) and Right Rear (RR) burners on HIGH with Left Rear (LR) and Right Front (RF) burners on LOW to create a crossray cooking pattern. Either way, **indirect cooking must be done with the Lid down.**

Prepare Cooking Grids for Grilling

- Greasing the cooking surface will help keep foods from sticking during the cookout, produces beautiful sear marks and reduces the amount of cleanup required. Use a brush to apply a thin layer of cooking oil or vegetable shortening onto each Cooking Grid before each cookout. We do not suggest spray type oils unless they are specified for high-temperature cooking.

To Reduce Flare-Ups and Smoke

- Fat and juice dripping from grilled food can cause flare-ups and smoke. To minimize this, cook your food in the mid section of each cooking grid so drippings fall through the center of the grill into the Grease/Water Tray below.

	WARNING	
<p>Failure to comply with these instructions could result in a fire or explosion that could cause serious bodily injury, death or property damage.</p> <ul style="list-style-type: none">℥ Never cover the cooking grids, bottom of grill bowl or Grease/Water Tray with charcoal, aluminum foil, sand or any substance that can absorb grease.℥ Before or after each use of your grill: Pull out the Grease/Water Tray and remove all grease and food debris to prevent a grease fire. It is important to keep this Tray 1/2 filled with water while grilling to get the best possible results. Wear a flame retardant BBQ Mitt when handling the Grease/Water Tray.℥ Use your grill at least 3 feet away from any wall or surface. Use your grill at least 3 feet away from combustible objects that can melt or catch fire (such as vinyl or wood siding, fences and overhangs) or sources of ignition including pilot lights on water heaters and live electrical appliances.℥ Never use your gas grill in a garage, porch, shed, breezeway or any other enclosed area.℥ Your grill will get very hot. Always wear a flame retardant BBQ Mitt when cooking on your grill and handling the Grease/Water Tray. Never lean over cooking areas while using grill. Do not touch cooking surfaces, Lid, grill housing or other parts while grill is in operation, or until the grill has cooled down after use. Be aware that the Tray does contain water and grease and be extremely careful when removing to prevent spillage.		

Guide to Infrared Grilling using the Direct Cooking Method

Grilling Steak and Ribs

Fill Grease/Water Tray half-full. Turn the grill Burners on 🔥, close the Lid and preheat your grill 3 to 5 minutes. Open Lid and place food on the mid section of a Cooking Grid. Sear 2-3 minutes on each side then adjust the Infrared Burners to LOW and continue cooking until desired doneness. You can also move the seared meat to the Secondary Cooking Rack to finish cooking. This method allows you to sear and prepare larger amounts of meat and keep cooked food warm. Grilling times will vary according to meat thickness.

Grilling Hamburgers, Brats and Sausages

Fill Grease/Water Tray half-full. Turn the grill Burners on 🔥, close Lid and preheat your grill 3 to 5 minutes. Open Lid and place food on the mid section of a Cooking Grid. Sear 2-3 minutes on each side then adjust the Infrared Burners to LOW and continue cooking until desired doneness. Grilling times will vary according to meat thickness.

Grilling Poultry

Fill Grease/Water Tray half-full. Turn the grill Burners on 🔥, close Lid and preheat your grill 2 to 3 minutes. Open Lid and place food on the mid section of a Cooking Grid. Sear 2-3 minutes on each side then adjust the Infrared Burners to LOW and continue cooking until desired doneness.

To minimize flare-ups, use skinless poultry or use the indirect method. Place the poultry on one side of the grill with the opposing Burners on LOW heat, and lower the grill Lid.

Grilling Pork

Fill Grease/Water Tray half-full. Turn the grill Burners on 🔥, close Lid and preheat your grill 3 to 5 minutes. Open Lid and place food on the mid section of a Cooking Grid. Sear 2-3 minutes on each side then adjust the Infrared Burners to LOW and continue cooking until desired doneness. Grilling times will vary according to meat thickness.

Whole Fish and Whole Fillets

Fill Grease/Water Tray half-full. Turn the grill Burners on 🔥, close Lid and preheat your grill 3 to 5 minutes. Open Lid and place food (skin down) on the mid section of a Cooking Grid. Sear 2 minutes on each side then adjust the Infrared Burners to LOW and continue cooking until fish is opaque but still moist.

Vegetables and Fruit

Fill Grease/Water Tray half-full. Prepare your fruit or vegetables and brush with butter or basting sauce if desired. In some instances, you may want to grill vegetables and fruit **directly** over the heat, using the supplied Cooking Grids. Foods that work best with direct heat are relatively soft and require a short cooking time: mushrooms, zucchini, tomatoes and skewered fruit such as apricots, peaches, pineapple, strawberries and kiwis. Remember the **Grill Lid must remain up when cooking directly.**

To cook **indirectly**, the food should be placed on the left or right side of your grill (or Secondary Rack) with the Burners lit on the opposite side. Either way, **indirect cooking must be done with the Lid down.**

Cut of Meat

T-bone steak
Sirloin steak
Beef spare ribs
Porterhouse Steak
New York strip steak

Approx. Total Cooking Times

Rare: 4-6 minutes
Medium: 6-8 minutes
Well done: 8-10 minutes

Hamburgers
Brats
Sausages

Rare: 3-4 minutes
Medium: 5-6 minutes
Well done: 6-8 minutes

Chicken breast
(cook with bone down)
Chicken wings
Drumsticks

Direct method:
approximately 6-8 minutes
Indirect method:
up to 30 minutes

Whole bird
(cook with breast up)

Indirect method:
approximately 1 hour

Chops
Loins
Cutlets

Medium: 10-12 minutes
Well done: 12-14 minutes

Whole fish
Whole fish fillets

Approx. 8 - 18 minutes or
until fish is opaque

For very firm vegetables—particularly potatoes and yams, we recommend that you partially boil until almost cooked, before placing them on the grill.

CAUTION: Infrared cooking times will be much shorter than traditional grilling so never operate this appliance unattended.

NOTE: Do not use aluminum foil to wrap vegetables and fruit. Infrared heat does not cook through aluminum foil and reflective pans.

Guide to Roasting & Baking using the Indirect Cooking Method

An Important Note About Infrared Heat Settings

The suggested heat settings and cooking times shown are approximate. Unlike the controlled environment inside your kitchen, variables including outside temperatures, direction and conditions of wind, as well as grill location will affect your grill's heat distribution. Because these conditions vary, and no two backyards are alike, we offer these tips as general guidelines for your reference. We recommend you monitor your grill closely and rotate foods often to prevent overcooking and ensure the most delicious results every time.

Preparing to Roast

Roasting uses the **indirect cooking** method. Therefore, the food should be placed on the left or right side of your grill with the Burners lit on the opposite side. You can also use an optional cast-iron pan underneath food allowing you to collect juices for making gravies. Remember, indirect cooking requires the Lid of your grill to be down.

Fill Grease/Water Tray half-full. Preheating your grill is not required for slow cooking methods such as roasting. If you do choose to preheat your grill before roasting, turn the Burners on HIGH and close Lid for approximately 2 minutes.

Food preparation

Trim meat of excess fat. Truss meat and poultry with cooking string to retain shape if desired. Bacon strips can be used to cover the outside surface of lean meat and poultry to help prevent it from drying out. To keep food moist during roasting be sure to keep the Grease/Water Tray filled. If using an optional cast-iron pan for cooking, you should also add liquid to prevent burning the bottom of your food.

Tips for roasting

Except when roasting with water in a roasting pan, the juices that collect in the pan can be used as the base for a tasty sauce or gravy. Place a cooking pan directly over the cooking grids, add extra butter if needed, then add several spoonfuls of flour to thicken sauce. Finally, add sufficient chicken or beef stock to obtain the desired consistency.

Once the meat is cooked, remove it from your grill and cover with a piece of foil. Allow it to stand for 10-15 minutes which allows the juices to settle. This will make carving easier and ensure a tender, juicy roast.

Type of Food	How Cooked	Approximate Cooking Times
Beef	Rare	14 minutes per pound
	Medium	18 minutes per pound
	Well done	20 minutes per pound
Lamb	Medium	14 minutes per pound
	Well done	18 minutes per pound
Veal		22 minutes per pound
Pork		23-26 minutes per pound
Chicken		17-20 minutes per pound
Duck		20 minutes per pound
Fish		8 minutes per pound
Turkey, under 16 pounds		17-20 per pound + 20 minutes
Turkey, over 16 pounds		14-18 per pound + 10 minutes

BAKING TECHNIQUES

Preparing to Bake

To bake in your new grill you'll need a baking dish or cast-iron cooking pan, and a pair of flame retardant BBQ Mitts. If the cooking pan is cast-iron be sure to season the pan before use.

Fill Grease/Water Tray half-full. Preheat your grill 3 minutes, then lower heat as needed. Baking uses the **indirect cooking** method. To cook **indirectly**, the food should be placed on the left or right side of your grill with the Burners lit on the opposite side. This is the slow cooking method. A faster indirect method is to place your food in an optional cast-iron cooking pan and place it in the center of the grill with all burners on LOW. If higher heat is desired, turn Left Front (LF) and Right Rear (RR) burners on HIGH with Left Rear (LR) and Right Front (RF) burners on LOW to create a crossray cooking pattern. Either way, **indirect cooking must be done with the Lid down.**

Tips for Baking

Prepare your favorite recipe as you would in the kitchen. You will need to stir the food several times as it bakes, and add additional liquid as required. Watch the temperature, and adjust to cook according to your recipe directions.

Oven Temperature

Slow	300° - 340° F
Moderate	355° - 390° F
High	410° - 480° F

Safe Minimum Internal Temperatures	
Fish	145°F/63°C
Pork	160°F/71°C
Egg Dishes	160°F/71°C
Steaks and Roasts of Beef, Veal or Lamb	145°F/63°C
Ground Beef, Veal or Lamb	160°F/71°C
Whole Poultry (Turkey, Chicken, Duck, etc.)	165°F/74°C
Ground or Pieces Poultry (Chicken Breast, etc.)	165°F/74°C

Recommended Grill Setting

Left or right 2 burners on LOW
All 4 burners on LOW
LF + RR burners on HIGH and LR + RF burners on LOW

Infrared Rotisserie Cooking

Balancing the Food

In rotisserie cooking, balancing the food is of utmost importance. The rotisserie must turn evenly or the stopping and starting action will cause the food to cook unevenly and possibly burn the heavier side.

The easiest foods to balance are those of uniform shape and texture. To test if the food is balanced correctly when secured, place the ends of the rotisserie spit loosely in the palms of your hands. If there is no tendency to roll, give the spit a quarter turn. If it is still stable, give it a final quarter turn. It should rest without turning in each of these positions. It can then be attached to your grill.

Food Preparation

When preparing poultry, truss the birds tightly so that wings and drumsticks are close to the body of the bird. The cavity of the bird may be stuffed prior to this. Pull the neck skin down and, using a small skewer, fix it to the back of the bird. Push the rotisserie spit through lengthwise, catching the bird in the fork of the wishbone. Center the bird and tighten with the holding forks. Test the balance as described before.

A rolled piece of meat requires the rotisserie skewer to be inserted through the center of the length of meat, then secured and balanced. For meats that contain bones, it is best to secure the rotisserie skewer diagonally through the meaty sections.

Slow Cooking with a Rotisserie

Your Crossray Infrared Cooking System® by Grand Hall is the ideal set-up for Rotisserie cooking because of the unique position and angle of the infrared burners. Rotisserie cooking produces foods that are moist, flavorful and attractive. The Rotisserie Kit is most commonly used for cooking meat or poultry and is designed to cook food slowly.

After your food is balanced on the Rotisserie Spit and attached to your grill, **fill Grease/Water Tray half-full** and turn the Rotisserie motor on. Observe the rotation to be sure the Rotisserie is turning evenly, then turn the front and rear Burners on LOW. Infrared rotisserie cooking on LOW heat can be done with the Lid open or closed.

CAUTION: DO NOT rotisserie cook with all burners on high and the Lid closed. The intense infrared heat will overcook your food and can damage your grill. Never operate this appliance unattended.

	WARNING	
FIRE HAZARD		
<ul style="list-style-type: none">• DO NOT use a cooking pan beneath food while rotisserie cooking.		

Guide to Smoking

Preparing to Smoke

Smoking gives food a distinctive, delicious flavor. You will find a variety of wood chips available for use in smoking grilled foods. Pre-soaking of wood chips may be required so read and follow the manufacturer's instructions for preparing smoking chips prior to use.

NOTE: It is our experience that many smoking chip products do not actually produce a smoke but instead infuses the food with flavor. Please read product labels carefully and if in doubt, ask your retailer for details.

Using A Cast-Iron Smoker Box

There are many optional smoker boxes available for purchase but cast-iron is the type recommended for use with your infrared grill. Follow these guidelines and always refer to the label of your smoking chips for specific directions.

Fill Grease/Water Tray half-full. Turn the front or rear grill burners on HIGH, close Lid and preheat your grill 3 to 5 minutes. Fill your smoker box with your prepared smoking chips. Wear a flame retardant BBQ Mitt and place your smoker box about 6 inches from the back of a Cooking Grid directly above a lit grill Burner. Allow smoker chips to heat about 30 minutes (or until the scent of smoke is evident) then turn Burners to LOW and add your food.

To cook **indirectly**, the food should be placed on the left or right side of your grill (or Secondary Rack) opposite the lit burners and smoker box. **When cooking with a smoker box the Lid must be down.**

Tips for Smoking

You can reduce the strength of the smoke flavor by only smoking for half or three quarters of the cooking time.

Foods naturally high in oils lend themselves well to smoking, while drier foods benefit from a marinade.

- **Tuna steaks**, marinated in Asian flavors of sesame oil, soy sauce and sherry.
- **Pork fillets**, rubbed with ginger, orange rind and brushed with maple syrup.
- **Mussels**, brushed with lemon rind and chili oil.
- **Lamb cutlets**, marinated in virgin olive oil, lemon, oregano and black pepper. The same marinade can be used for a whole leg or rack of lamb.
- **Chicken**, boneless chicken pieces—especially sliced breasts.
- **Fish**, sliced fillets of firm fish, assorted seafood such as prawns, scallops and calamari.
- **Pork**, sliced fillets, diced or minced pork, sliced leg steak, sliced chops.
- **Beef**, sliced fillet, rib-eye, round, rump, sirloin.
- **Lamb**, sliced fillet, round, loin.

Guide to Stir-Frying and Deep-Frying

STIR-FRYING TECHNIQUES

This method of cooking is popular around the world and can be easily accomplished outdoors on your gas grill. It's a quick and healthy way of preparing a complete meal using meat, poultry or seafood in infinite combinations with other interesting ingredients like vegetables, rice or noodles.

Preparing to Stir-fry

Although it is possible to stir fry in other dishes, a wok is your best tool. Its high sides enable the cook to stir food without spillage. Its construction allows you to cook quickly at high temperatures, with instant control of heat which is essential for successful stir frying.

Food Preparation

Slice meat and poultry into long thin strips and cube fish filets. Remove all fat from meat and poultry and cut large vegetables into even slices or cubes.

Marinate foods for extra flavor and tenderness. Marinating times will vary for red meat, fish and or various cuts. Less tender cuts of meat should be marinated longer. Remember to always chill marinating food in the refrigerator prior to cooking.

Stir-fry meats, poultry or fish first. Next, add hard vegetables like carrots. Then continue with softer vegetables like snowpeas and peppers. To ensure even cooking, continually stir and toss the food in the wok using a wooden spoon or spatula.

Tips for Stir-frying

Place a wok on a Cooking Grid in the path of direct infrared heat. Add only a small amount of food at a time to ensure fast cooking and also to allow the wok to reheat between ingredients.

DEEP-FRYING TECHNIQUES

A wide variety of foods can be deep-fried outdoors on your grill, from potatoes, to seafood and chicken. Deep-frying uses a large portion of oil, preferably saturated. The outdoor location is ideal for deep-frying as smoke, grease and smells disperse in the open air instead of collecting on the ceiling of your kitchen.

Preparing to Deep-fry

Deep-fry on your grill using an optional cast-iron pan placed on a Cooking Grid in the path of direct infrared heat.

Fill a cooking pan no more than half full of vegetable or corn oil. **Fill Grease/Water Tray half-full.** Turn the grill Burners on 🔥, close Lid and preheat your grill 3 to 5 minutes. Open Lid and place cast-iron pan on the mid section of a Cooking Grid then adjust the Infrared Burners to LOW.

Check the temperature of the oil carefully with a frying thermometer or test with a cube of bread. The cube of bread should brown in about 30 seconds for most cooking needs. 350° F (177° C) is the optimal temperature for preparing the majority of deep-fried foods.

Food Preparation

Foods being deep-fried taste better when coated with either batter or breadcrumbs to add flavor and prevent moisture from escaping.

Tips for Deep-frying

Wear a flame retardant BBQ Mitt and slowly lower foods into the hot oil using a wire scoop, fry-basket or stainless steel tongs. Add only a small quantity of food to the oil, allow it to cook, then repeat with another small quantity. This ensures the oil doesn't drop in temperature. Once the food is cooked, remove it carefully and drain onto a paper towel. Turn the heat off as soon as you have finished deep-frying and allow your pan to cool. When the oil is cool, remove all remnants of fried foods by straining it through a fine metal sieve, and store it in a clean bottle for future use.

Guide to Using the Secondary Cooking Rack

Vegetables are generally easy to cook on the grill. The Secondary Cooking Rack makes it convenient because you can still use the main cooking area while the vegetables are suspended above the grids.

Pre-cook hard vegetables by briefly boiling or microwaving them before cooking on the grill. Do not grill your vegetables wrapped in aluminum foil.

Infrared heat does not cook through aluminum foil and reflective pans. To keep vegetables moist, brush them with butter or oil often.

The Secondary Cooking Rack can be used for purposes other than just the obvious. Consider using the rack for warming French bread, garlic bread, croissants or even bagels.

Question:

Can I convert my grill from one fuel type to another in other words from LPG to NG or vice versa?

Answer:

No, your gas grill is manufactured to exact specifications and is certified for LPG (Liquid Propane Gas) or NG (Natural Gas) use only. For your safety, conversion kits are not available, nor will we sell or otherwise provide parts or information to be used to convert your grill. Any attempt to convert your grill is dangerous and will void your warranty.

Question:

Are the serial and model numbers of my grill listed somewhere for reference?

Answer:

The serial and model numbers are listed on a silver CSA label placed on the grill. Depending on the grill model the silver CSA label will be located on the left or right side bowl panel underneath the side shelf, underneath the right side of the control panel, outside left or right of control panel or on the back of the grill cabinet.

Question:

My grill will not light properly. Why?

Answer:

Always light the Main Burner farthest from the fuel source first. This will draw gas across the manifold helping prevent air pockets which obstruct gas-flow and prevent proper grill lighting. Also try this procedure:

1. Turn gas off at source and turn Control Knobs OFF. Wait at least 5 minutes for gas to clear, then retry.
2. If your grill still fails to light, turn the Burner Control Knob(s) and gas source OFF and conduct a leak test of ALL gas connections and gas sources as explained in the Use and Care section of this manual.
3. If no leaks are detected, wait 5 minutes for any gas to clear and repeat the lighting procedure.

Question:

If my ignitor or battery is not working how can I light my grill manually? And - Why would I need the silver lighting stick that hangs from the side of my grill?

Answer:

If your ignition fails to work or your battery needs replacing, you can light your grill using the Manual Lighting Stick. The Lighting Stick is designed to hold a paper match and allows you to safely insert a match through the Cooking Grid without getting close to the Burner. To light your gas grill manually, insert a paper match into the Manual Lighting Stick and follow steps 1 through 5 of the Basic Lighting Procedures. Then, light the match and place the Lighting Stick through the Cooking Grid. Turn the nearest main Burner Control Knob to the 🔥 setting to release gas. The Burner should light immediately.



WARNING



Never lean over the grill cooking area while lighting your gas grill. Keep your face and body a safe distance (at least 18 inches) from the front of grill when lighting your grill by match.

Question:

Sometimes I hear a humming sound coming from my regulator. What causes this? And - My grill has a low flame and sometimes will not light. Why?

Answer:

The humming sound is gas flowing through the regulator. A low volume of sound is normal and will not interfere with the operation of your grill. Loud or excessive regulator humming and/or low flow and intermittent lighting may be caused by the regulator's excess gas flow device. Opening the tank valve all the way or too quickly is what triggers the regulator's safety device to restrict gas flow, preventing excess gas flow to your grill. Lighting the main Burner farthest from the fuel source every time will help eliminate air pockets in the manifold. Note: This procedure should be done every time a new LP Gas tank is connected to your grill.

- Turn all Control Knobs to the OFF position.
- Turn off the LP Gas tank at the tank valve. For Natural Gas shut off NG valve.
- Disconnect regulator from LP Gas tank. For Natural Gas disconnect regulator from 12 ft. Natural Gas Hose.
- Let unit stand for 5 minutes.
- Reconnect regulator to the LP Gas tank. For Natural Gas reconnect regulator to 12 ft. Natural Gas Hose.
- Open grill Lid.
- Turn the tank valve slowly ¼ of one turn. For Natural Gas open Shut Off valve.
- Light main Burner farthest from fuel source.
- Turn the tank valve slowly one more ¼ of one turn for ½ of one complete turn.
- Continue to light Burners moving towards the fuel source.
- Do not turn tank valve more than ½ of one turn on LPG models.

Question:

Where do I use my grill for safer operation and better performance?

Answer:

- Strong winds and low temperatures can affect the heating and performance of your gas grill so factor in these elements when positioning your grill outdoors for cooking.
- In **windy conditions**, always position the front of grill to face oncoming wind to reduce heat and smoke blowing in your face and prevent potential hazards to yourself and the grill.
- Use your grill at least 3 feet away from any wall or surface.
- Use your grill at least **3 feet away** from combustible objects that can melt or catch fire (such as vinyl or wood siding, fences and overhangs) or sources of ignition including pilot lights on water heaters and live electrical appliances.
- Never** use your gas grill in a garage, porch, shed, breezeway or any other enclosed area.
- Never** obstruct the flow of ventilation air around your gas grill housing.

Question:

The Regulator and Hose supplied with my gas grill does not fit the older LP Gas tank I've used for years. Why not?

Answer:

The U.S. Government regulates gas appliances and LP Gas tanks. When regulations are changed the LP Gas tank fittings are altered to insure compliance. If your LP Gas tank does not fit the Regulator and Hose supplied with your new grill, the tank is outdated and must be replaced. Note: Effective April 1, 2002 all LP Gas tanks sold must include an "OPD" Overfill Prevention Device. The OPD tanks are identified by their triangular-shaped valve wheel. This internal device prevents the LP Gas tank from being overfilled. Tanks without an OPD valve can not be refilled.

Question:

What causes grill parts to rust and what effect does it have on my grill?

Answer:

Rusting is a natural oxidation process and will not affect the short term performance of your grill.

To slow the rusting process on the Cooking Grids, we recommend greasing the grids before and after each cookout. Use a brush to apply a thin layer of cooking oil or vegetable shortening onto each grid. We do not suggest spray type oils unless they are specified for high-temperature cooking.

Routine care and maintenance is required to preserve the appearance and corrosion resistance of stainless steel. The fact is stainless steel can corrode, rust and discolor under certain conditions. Rust is caused when regular steel particles in the atmosphere become attached to the stainless steel surface. Steel particles can also become attached to your grill if you use steel wool or stiff wire brushes to clean the grill instead of non-abrasive cloth, sponge or nylon cleaning tools. In coastal areas rust pits can develop on stainless surfaces that cannot be fully removed. Bleach and other chlorine based solutions used for household and pool cleaning can also cause corrosion to stainless steel.

Weathering, extreme heat, smoke from cooking and machine oils used in the manufacturing process of stainless steel can cause stainless steel to turn tan in color. Although there are many factors which can affect the surface appearance of stainless steel, they do not affect the integrity of the steel or the performance of the grill. To help maintain the finish of stainless steel follow these cleaning tips for the best results:

After every use (after your grill has cooled down), wipe stainless surfaces with a soft, soapy cloth or sponge then rinse with water. Be sure to remove all food particles, sauces or marinades from stainless steel because these can be highly acidic and damaging to stainless surfaces.

Never use abrasive cleaners, scrubbers or stiff wire brushes of any type on your grill. Use a heat resistant Stainless Steel Cleaner and rub or wipe in the direction of the stainless steel grain or polish lines. Do not polish against the grain.

Grand Hall Limited Warranty

Grand Hall will warrant to the ORIGINAL PURCHASER of this product that it will be free of defects in material and workmanship for set periods below from the date of purchase when used under normal outdoor use and correct assembly:

All Stainless Steel Parts - Limited Lifetime Warranty

All Electrical Components (excluding Ignitor Battery) - 1 Year Limited Warranty

All Other Grill Parts - 5 Year Limited Warranty

Grand Hall will require reasonable proof of your date of purchase. Therefore, you should send in the owner registration card or register online at www.grandhall.com. Save your receipt in case it is required as proof of purchase.

This Limited Warranty is limited to replacement of parts at Grand Hall's option that proved to be defective under normal use and service.

Grand Hall may require the return of defective parts for examination before issuing replacement parts. If you are required to return defective parts, shipping charges must be prepaid. No returns will be accepted without prior authorization from Grand Hall.

Upon examination and to Grand Hall's satisfaction, if the original part is proven defective, Grand Hall may approve your claim and elect to replace such parts without charge. You will be charged for shipping and handling of the replacement parts.

This Warranty does not cover any failures or operating difficulties due to accident, abuse, misuse, alteration, misapplication, vandalism, improper installation, maintenance, operation or service, as set out in the Operator's Manual.

This Warranty does not cover cosmetic wear and tear such as scratches, dents, corrosion or discoloration caused by weather, heat, chemicals, paint loss, or surface rust. Deterioration or damage due to severe weather conditions such as hail, hurricanes, earthquakes, tsunamis, tornadoes, Act of God or terrorism is not covered by this Limited Warranty.

To Obtain Warranty:

Call 1-877-934-7455

Monday through Friday

8am - 4:30pm CST

Warranty Restrictions

This Warranty is non-transferable and is void if product is used for commercial or rental purposes.

This Warranty applies only when the product is used in the United States or Canada.

This Warranty gives you specific legal rights, and you may also have other rights which vary from state to state.

Manufacturer:

Grand Hall Enterprise Co., Ltd.

9th Fl., No. 298, Rueiguang Rd., Neihu,

Taipei, Taiwan (114)