

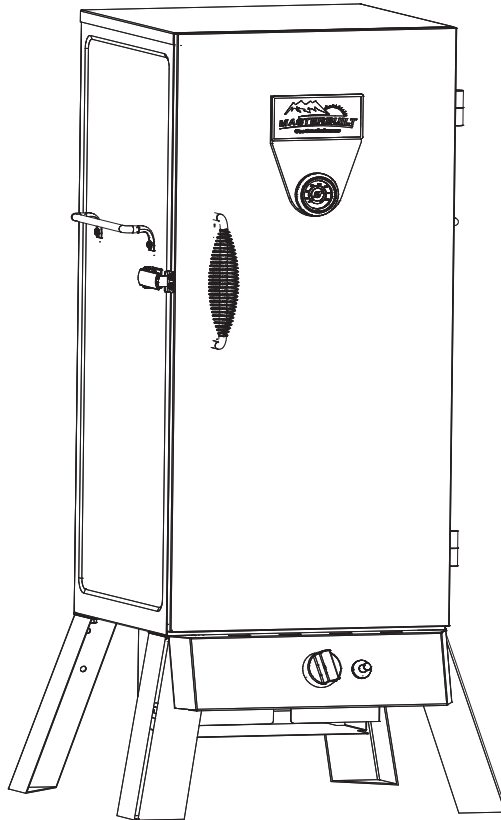





**ASSEMBLY, CARE & USE MANUAL  
WARNING & SAFETY INFORMATION  
PROPANE SMOKER MODEL 20051011  
THIS PRODUCT IS FOR OUTDOOR USE ONLY**

Manual Code: 9805100022 041811-04JH



\*Actual product may differ from picture shown

Tools needed for assembly: Adjustable Wrench, Phillips Head Screwdriver

 <b>CARBON MONOXIDE HAZARD</b> 	 <b>WARNING</b> 
<p align="center"><b>Burning wood chips gives off carbon monoxide, which has no odor and can cause death.</b></p> <p align="center"><b>DO NOT burn wood chips inside homes, vehicles, tents, garages or any enclosed areas.</b></p> <p align="center"><b>Use only outdoors where it is well ventilated.</b></p>	<p align="center"><b>This manual contains important information necessary for the proper assembly and safe use of the appliance.</b></p> <p align="center"><b>Read and follow all warnings and instructions before assembling and using the appliance.</b></p> <p align="center"><b>Follow all warnings and instructions when using the appliance.</b></p> <p align="center"><b>Keep this manual for future reference.</b></p>
<p align="center"><b>Failure to follow these warnings and instructions properly could result in fire or explosion, which could cause property damage, personal injury, or death.</b></p>	

⚠ DANGER ⚠	⚠ DANGER ⚠
<p>If you smell gas:</p> <ol style="list-style-type: none"> <li>1. Shut off gas to the appliance.</li> <li>2. Extinguish any open flame.</li> <li>3. Open/remove door.</li> <li>4. If odor continues, keep away from the appliance and immediately call your Fire Department.</li> </ol>	<ol style="list-style-type: none"> <li>1. Never operate this appliance unattended.</li> <li>2. Never operate this appliance within 10 feet (3m) of any structure, combustible material or other gas cylinder.</li> <li>3. Never operate this appliance within 25 feet (7.5m) of flammable liquids.</li> <li>4. If fire should occur keep away from appliance and immediately call your fire department. Do not attempt to extinguish an oil/grease fire with water.</li> </ol>
<p><b>FAILURE TO FOLLOW THESE INSTRUCTIONS COULD RESULT IN FIRE, EXPLOSION OR BURN HAZARD, WHICH COULD CAUSE PROPERTY DAMAGE, PERSONAL INJURY OR DEATH.</b></p>	

⚠ GENERAL WARNINGS AND SAFETY INFORMATION ⚠
<ul style="list-style-type: none"> <li>• Unit is for outdoor use only.</li> <li>• Never use inside enclosed areas such as patios, garages, buildings or tents.</li> <li>• Never use inside recreational vehicles or on boats.</li> <li>• Never operate unit under overhead construction such as roof coverings, carports, awnings, or overhangs.</li> <li>• Never use unit as a heater.</li> <li>• Maintain a minimum distance of 10ft (3m) from overhead construction, walls, rails or other structures.</li> <li>• Keep a minimum 10ft (3m) clearance of all combustible materials such as wood, dry plants, grass, brush, paper, or canvas.</li> <li>• Keep appliance clear and free from combustible materials such as gasoline and other flammable vapors and liquids.</li> <li>• Use unit on a level, non-combustible, stable surface such as dirt, concrete, brick or rock.</li> <li>• Keep children and pets away from unit at all times. Do NOT allow children to use unit.</li> <li>• Unit has an open flame. Keep hands, hair, and face away from burner flame. Do NOT lean over burner when lighting. Loose hair and clothing may catch fire.</li> <li>• Allow unit to cool below 115°F (46°C) before moving or storing.</li> <li>• Avoid bumping or impacting unit.</li> <li>• This unit is HOT while in use and during cooling process. Wear protective gloves/mitts.</li> <li>• Use of alcohol, prescription or non-prescription drugs may impair user's ability to properly assemble or safely operate unit.</li> <li>• Never use glass, plastic or ceramic cookware in unit.</li> <li>• Do NOT allow anyone to conduct activities around unit during or following its use until it has cooled.</li> <li>• Accessory attachments not supplied by Masterbuilt Manufacturing, Inc. are not recommended.</li> <li>• Never use unit for anything other than its intended use. This unit is NOT for commercial use.</li> <li>• Use in accordance with local, state and federal fire codes.</li> </ul>

⚠ GENERAL WARNINGS AND SAFETY INFORMATION ⚠
<ul style="list-style-type: none"> <li>• Use 20LB (9kgs) gas cylinder that has protective collar (cylinder not included with unit).</li> <li>• Installation of unit must conform with local codes or in the absence of local codes, with National Fuel Gas Code, ANSI Z223.1/NFPA 54, Storage and Handling of Liquefied Petroleum Gases, ANSI/NFPA 58 or CSA B149.1, Natural Gas Installation Code; Propane Storage and Handling, CSA B149.2; or the Standard for Recreational Vehicles, ANSI A119.2/NFPA 1192; and Recreational Vehicle Code, CSA Z240 RV Series as applicable.</li> <li>• LP gas cylinder being used must be constructed and marked in accordance with specifications for LP gas cylinders of the US Department of Transportation (DOT) or the Standard for Cylinders, Spheres and Tubes for the Transportation for Dangerous Goods, CAN/CSA-B339.</li> <li>• Always perform soapy water test (see "Soapy Water Test Instructions" in this manual) EVERY TIME you use unit.</li> <li>• Before each use check all nuts, screws and bolts to make sure they are tight and secure.</li> <li>• Before each use inspect gas hose for signs of damage.</li> <li>• Always disconnect gas cylinder from unit when not in use.</li> <li>• Never attach/disconnect gas cylinder, move or alter gas fittings when unit is in operation.</li> <li>• Never use gas cylinder if there is evidence of dents, gouges, bulges, fire damage, erosion, leakage, excessive rust, or other forms of visible external damage. This may be hazardous and cylinder should be taken to a liquid propane supplier to be checked.</li> <li>• Regulator and hose assembly supplied with unit MUST be used. For replacement parts, if needed, contact Masterbuilt Customer Service at 1-800-489-1581.</li> <li>• When lighting burner remove all smoker parts to prevent explosion from gas build up.</li> <li>• If ignition does not take place within five seconds using ignitor button, turn gas control valve to off position and wait five minutes and repeat lighting procedures.</li> <li>• Keep fuel supply hose away from unit while in operation.</li> <li>• Keep fuel supply hose away from any heated surface.</li> <li>• Do NOT obstruct flow of combustion and ventilation. Keep ventilation openings of cylinder enclosure free and clear of debris.</li> <li>• When use is complete, always turn regulator control valve OFF first, then gas cylinder valve OFF.</li> <li>• Gas MUST be turned off at the supply cylinder when not in use.</li> <li>• Do NOT store spare LP gas cylinder under or near unit. Gas cylinder safety relief valve may overheat allowing gas to release causing fire which may cause death or serious injury.</li> <li>• Never fill cylinder over 80% full or cylinder may release gas causing fire which may cause death or serious injury.</li> <li>• If you smell, hear or see gas escaping, immediately get away from gas cylinder and call the Fire Department. Fire may cause death or serious injury.</li> <li>• Place a dust cap on cylinder valve outlet whenever cylinder is not in use. Only install dust cap provided with cylinder. Other caps or plugs may cause leaks.</li> <li>• Cylinder MUST be stored outdoors, out of children's reach and must NOT be stored in a building, garage, or any other enclosed area.</li> <li>• This appliance is not for frying turkeys.</li> </ul>

## SOAPY WATER TEST WARNINGS & PROCEDURES

### WARNINGS

- Soapy Water Test **MUST** be performed each time gas cylinder is connected to burner/hose or each time it is used.
- Soapy Water Test **MUST** be performed outdoors in well ventilated area.
- When performing Soapy Water Test keep smoker away from open flames, sparks or lit cigarettes.
- Smoker is designed to work with propane gas only. Only use gas cylinders marked propane with this unit. This product will **NOT** operate with natural gas.
- Never use an open flame to test for gas leaks.

### PREPARATION:

- Remove any cookware from smoker.
- Make sure regulator and gas cylinder valve to OFF position.
- Prepare soapy water solution: (1) part dish washing liquid (or more if desired), (3) parts water.
- Apply soapy water solution to gas cylinder valve, regulator and hose length up to burner.

Apply solution to gas cylinder valve

Apply solution to hose regulator and the full length of the hose

Apply solution underneath control panel where burner and hose are connected

Failed test will present bubbles as shown below.

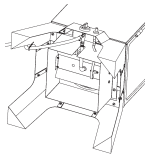
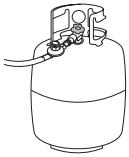

(Smoker shown on back for clarity only)

### TESTING GAS VALVE:

- Turn gas cylinder valve ON and watch for bubbles. **DO NOT LEAVE GAS ON MORE THAN 12 SECONDS.** If bubbles appear, stop, turn gas cylinder OFF and retighten fitting. Repeat test.

### TESTING REGULATOR AND HOSE:

- **AFTER** gas cylinder valve has passed Soapy Water Test, turn gas cylinder valve ON, open regulator control valve one full turn and check for bubbles at valve location, along full length of hose and at burner connection. **DO NOT LEAVE GAS ON MORE THAN 12 SECONDS.** If bubbles appear, stop, turn regulator valve OFF, turn gas cylinder OFF and retighten the connection that is leaking gas. If hose is source of leak, STOP, do not use unit. Hose must be replaced.
- When test is complete, and there are no leaks, wait minimum of 5 minutes for gas fumes to diminish before lighting cooker.

**DURING ANY PORTION OF SOAPY WATER TEST IF BUBBLES CONTINUE TO APPEAR, STOP, DO NOT USE UNIT. CONTACT LOCAL PROPANE DEALER OR MASTERBUILT CUSTOMER SERVICE @ 1-800-489-1581.**

**Note:** Use 20LB (9kgs) gas cylinder that has a protective collar with this unit. Cylinder NOT included with this unit.

## WARNING

**PERFORM "SOAPY WATER TEST" BEFORE EACH USE. SEE "SOAPY WATER TEST" SECTION IN MANUAL. EXTINGUISH ALL OPEN FLAMES BEFORE CONNECTING REGULATOR TO GAS CYLINDER. TURN GAS OFF AFTER EACH USE.**

## REGULATOR, BURNER AND GAS VALVE CONNECTION & OPERATION

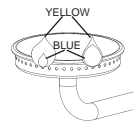
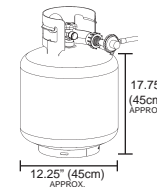
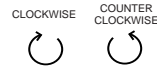

- Inspect hose before each use. If there are signs of wear, cuts, or leaks, replace unit. **DO NOT USE.**
- Inspect burner before each use. Check burner and burner ventura tube for insects and insect nests. A clogged tube can lead to a fire beneath appliance.
- Connect hose regulator to LP Gas Cylinder
  1. Make sure gas cylinder valve is closed. Turn knob clockwise until it stops.
  2. Make sure control knob on smoker is in the "OFF" position.
  3. Remove protective cap from gas cylinder and coupling nut if applicable.
  4. Center and insert regulator nipple into valve outlet on gas cylinder as shown in figure on the left. Turn regulator coupling nut clockwise until it stops. **DO NOT OVER TIGHTEN.**
- Perform Soapy Water Test.
- To use turn gas cylinder ON, turn regulator control valve ON, push burner control knob in and turn counter-clockwise ¼ turn. Push ignitor button to light.
- If ignition does not take place within five seconds, turn gas control valve to off position and wait five minutes and repeat lighting procedures. If ignition still does not occur, see match light directions below.
- After use turn burner control knob OFF, turn regulator control valve OFF, then turn gas cylinder OFF.
- Burner control knob adjusts burner flame. Turn knob counter-clockwise to decrease flame. Turn knob clockwise **SLOWLY** to increase flame. Push burner control knob in and turn clockwise to shut flame off.
- Visually check burner flame. A **CORRECT FLAME** should be blue with a small amount of yellow at the tip. An **INCORRECT FLAME** is excessively yellow and irregular. If an incorrect flame occurs, turn burner control knob to "OFF" position, turn off regulator and propane tank. Allow unit to cool and then clean burner. Let burner completely dry before re-lighting.

## MATCH LIGHT INSTRUCTIONS

1. Read all instructions and warnings before lighting.
2. Check gas control valve and gas cylinder valve to be certain it is in OFF position before connecting to gas cylinder. Perform soapy water test before each use.
3. Open door during lighting.
4. Turn gas control valve on, turn gas cylinder valve on.
5. Place a long, lit fireplace match stick close enough to burner to ignite.
6. After each use, first turn gas control valve off, then gas cylinder valve off. Always allow unit to cool completely before touching, moving or storing.

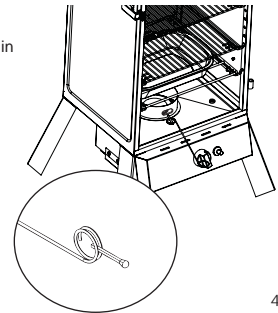



**DO NOT RETURN TO RETAILER** For Assembly Assistance, Missing or Damaged Parts  
Call: MASTERBUILT Customer Service at 1-800-489-1581.  
Please have Model Number and Serial Number available when calling.  
These numbers are located on silver label on back of unit.

**PARTS LIST**

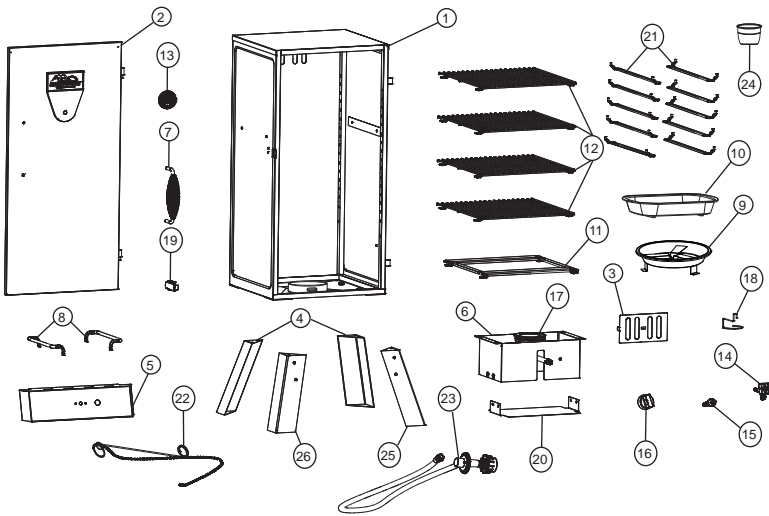

PART NO	QUANTITY	DESCRIPTION	PART NO	QUANTITY	DESCRIPTION
1	1	Smoker Body	14	1	Valve (pre-assembled)
2	1	Smoker Door	15	1	Ignitor (pre-assembled)
3	1	Air Damper (pre-assembled)	16	1	Control Knob (pre-assembled)
4	2	Rear Legs	17	1	Burner (pre-assembled)
5	1	Control Panel	18	1	Grease Clip
6	1	Burner Box	19	1	Door Latch
7	1	Door Handle	20	1	Heat Shield
8	2	Body Handle	21	10	Cooking Grate Support
9	1	Flame Disk Bowl	22	1	Matchstick w/Chain (pre-assembled)
10	1	Water Bowl	23	1	Regulator/Hose
11	1	Water Bowl Holder	24	1	Drip Cup
12	4	Cooking Grate	25	1	Right Front Leg
13	1	Temperature Gauge	26	1	Left Front Leg

**HARDWARE LIST**

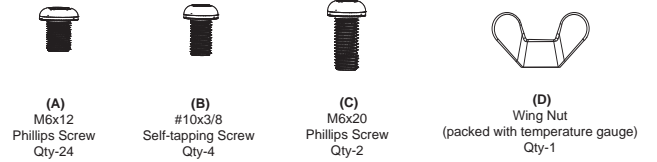

**REPLACEMENT PARTS LIST**

Model 20051011		
PART NO	REPLACEMENT PART	ITEM NO
1	Body Kit	990510009
2	Door with Logo Plate	9005100052
3	Air Damper Kit	9904090069
4	Rear Leg Kit	9905100002
5	Control Panel Kit	9905100011
6	Burner Box Kit	9905100005
7	Door Handle Kit	9905090003
8	Body Handle Kit	9905100003
9	Flame Disk Bowl	911060006
10	Water Bowl	9005100017
11	Water Bowl Holder	9005100016
12	Cooking Grate	9005100015
13	Temperature Gauge Kit	9907090034
14	Valve Kit	990060291
15	Ignitor Assembly Kit	990060328
16	Control Knob	911060014
17	Burner	9005100042
18	Grease Clip	9005100025
19	Door Latch Kit	990502222
21	Cooking Grate Support	9005100010
22	Match Stick with Chain	908060003
23	Regulator/Hose	911060001
24	Drip Cup	9005100039
25	Right Front Leg Kit	9905100021
26	Left Front Leg Kit	9905100020
	Hardware Kit	9905100008
	Instruction Manual	9805100022



**DO NOT RETURN TO RETAILER** For Assembly Assistance, Missing or Damaged Parts  
Call: MASTERBUILT Customer Service at 1-800-489-1581.  
Please have Model Number and Serial Number available when calling.  
These numbers are located on silver label on back of unit.

## ASSEMBLY

- BEFORE ASSEMBLY READ ALL INSTRUCTIONS CAREFULLY.
- ASSEMBLE UNIT ON A CLEAN, FLAT SURFACE.
- TOOLS NEEDED: ADJUSTABLE WRENCH, PHILLIPS HEAD SCREWDRIVER

Carefully position grill as shown.

Do not tighten screws all the way. Leg frames may need to be adjusted during assembly.

**STEP 1**  
Attach rear legs (4), right front leg (25) and left front leg (26) to bottom of smoker body (1) using phillips screws (A).

Do not fully tighten screws yet.

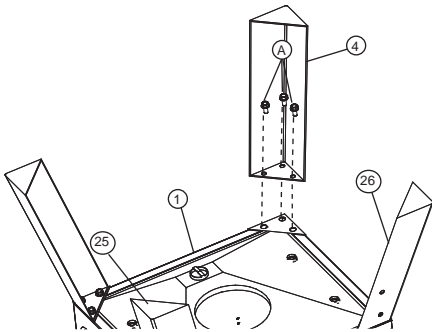

**STEP 2**  
Attach control panel (5) to right front leg (25) as shown using phillips screws (A).  
Repeat on opposite side attaching control panel (5) to left front leg (26).

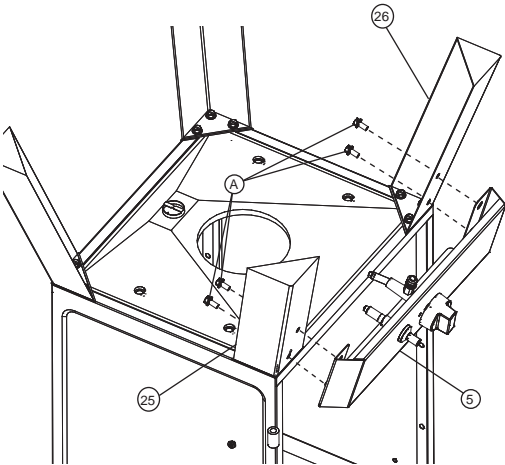

## ASSEMBLY

**STEP 3**  
Position burner box (6) over center hole in bottom of smoker body, carefully aligning venturi over valve orifice as shown. Attach burner box to smoker body using phillips screws (A).

Firmly attach ignition wire to piezo ignitor on control panel as shown in Figure B.

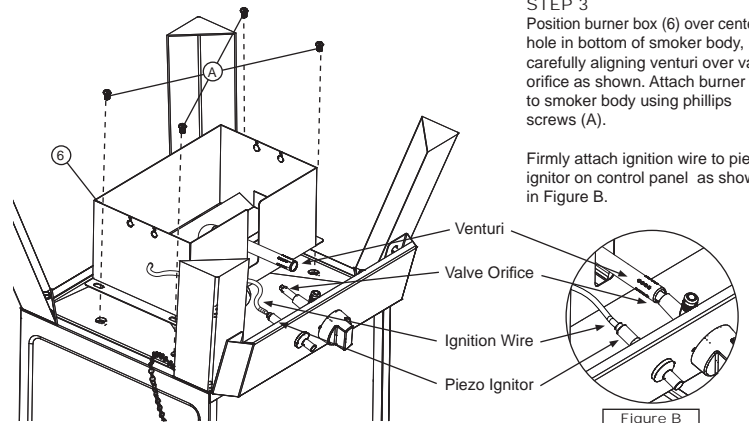

**STEP 4**  
Attach heat shield (20) to burner box (6) using self tapping screws (B) as shown.

**Tighten all hardware at this time.**

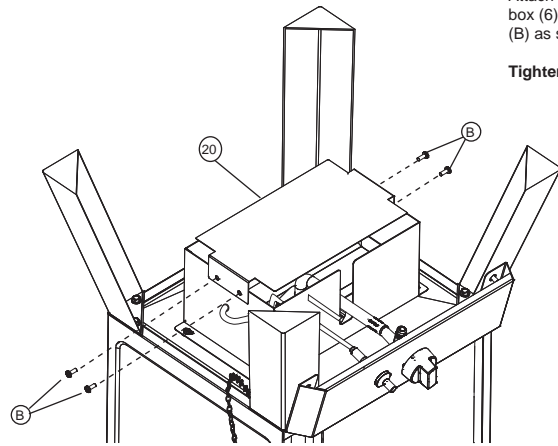

**ASSEMBLY**

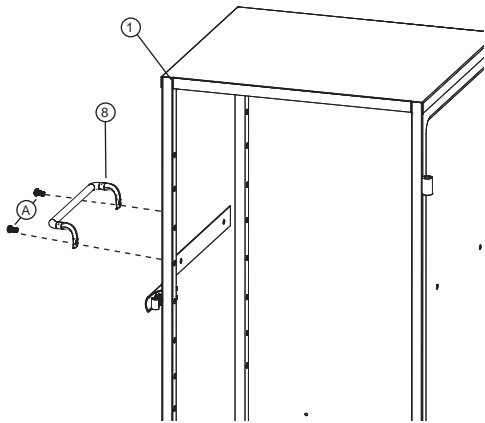

**STEP 5**  
Mount body handle (8) to smoker body (1) using phillips screws (A).

**ASSEMBLY**

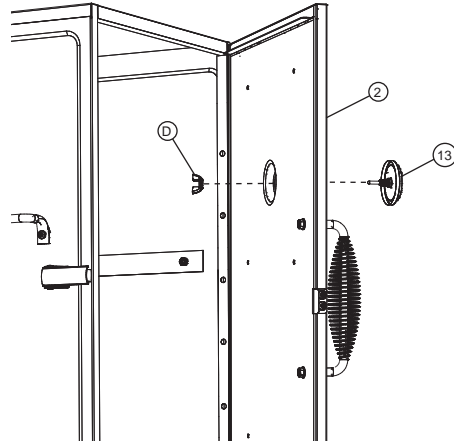

**STEP 7**  
Insert temperature gauge (13) into smoker door (2). Secure in place with wing nut (D).

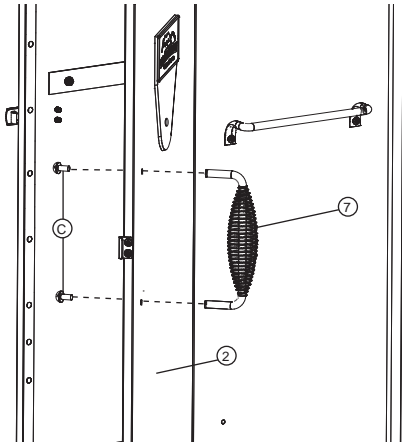

**STEP 6**  
Insert door handle (7) into smoker door (2). Secure using phillips screws (C).

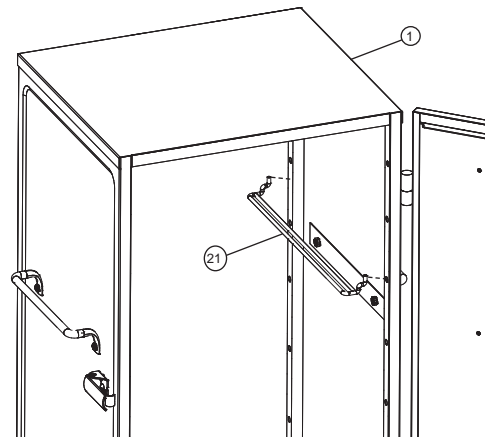

**STEP 8**  
Insert cooking grate supports (21) into smoker body (1).

**ASSEMBLY**

**STEP 9**  
Slide cooking grates (12), onto cooking grate supports (21).

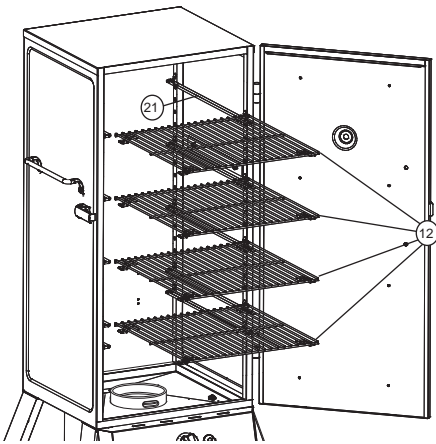

**ASSEMBLY**

**STEP 11**  
Insert small hook end of grease clip (18) all of the way up through large hole in bottom of smoker body (1), turn grease clip clockwise/counter-clockwise so that it is supported on small tab.

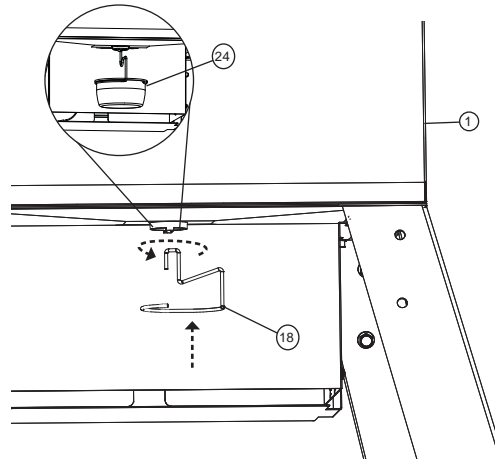

Position drip cup (24) on grease clip so it rests snugly.

Drip cup is needed to collect grease run-off.

**Note:** Clip may require adjustment to fit diameter of container.

**STEP 10**  
Insert water bowl (10) into water bowl holder (11) and slide water bowl holder (11) onto cooking grate support (21).

Place flame disk bowl (9) into smoker as shown.

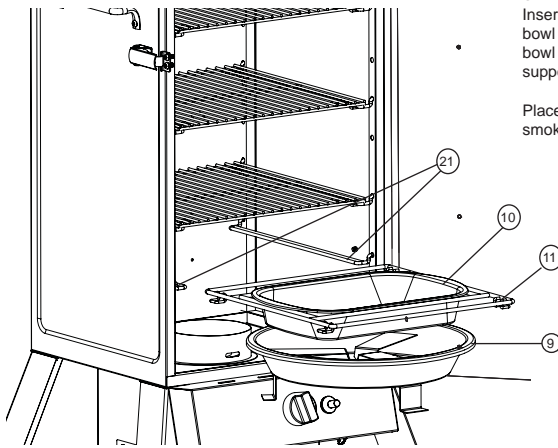

**STEP 12**  
Hang matchstick (22) on side of smoker body (1) as shown.

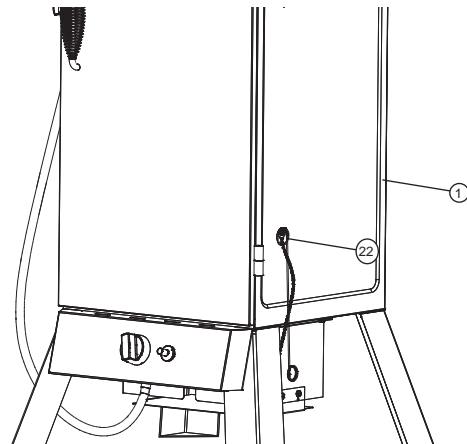

## ASSEMBLY

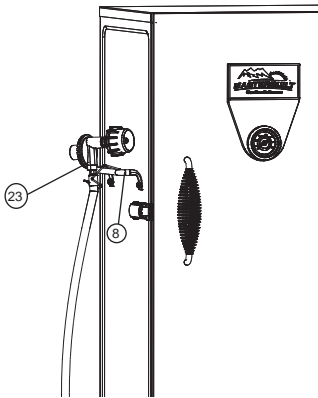

**STEP 13**  
When not in use, hang regulator/hose (23) on body handle (8) as shown.

## PRE-SEASON INSTRUCTIONS

Curing your smoker will rid the unit of chemicals and oils left over by the manufacturing process allowing them to burn off. **Preseason smoker prior to first use.**

1. Perform soapy water test (see pg. 3).
2. Using a napkin or cloth, rub a light coat of cooking oil on cooking grates and inside smoker door.  
Make sure water pan is in place with **NO WATER**.
3. Fill flame disk bowl with 1-2 cups (0.24l-0.56l) wood chips and light smoker. Close door.
4. Let the smoker burn for about 30 minutes. Make sure temperature gets up to 400°F (204°C).
5. Allow unit to cool completely.
6. Reapply light coat of cooking oil on the grilling surface and inside of smoker door.
7. Relight smoker and burn the oil for 20 minutes.

- Cure your smoker periodically to prevent excessive rust.

**SMOKER IS READY FOR USE**

## TIPS FOR USING WOOD CHIPS

- Pre-soak wood chips in water for at least 30 minutes.
- Before starting unit, place 1-2 cups (0.24l-0.56l) of wood chips in flame disk bowl.
- Never use more than 2 cups (0.56l) of wood chips at a time. Never use wood chunks.
- Check flame disk bowl periodically to see if wood has burned down. Add more chips as needed.

## WOOD SMOKING GUIDE FOR MEATS

WOOD FLAVOR	POULTRY	FISH	HAM	BEEF	PORK	LAMB
<b>Hickory</b> Pungent, smoky, bacon-like flavor	✓	✓	✓	✓	✓	
<b>Mesquite</b> Sweet and delicate flavor	✓			✓		✓
<b>Alder</b> Delicate, wood smoke flavor	✓	✓			✓	
<b>Pecan</b> Bold and hearty flavor	✓	✓			✓	
<b>Maple</b> Sweet, subtle flavor	✓				✓	
<b>Apple</b> Sweet, delicate flavor	✓	✓			✓	
<b>Cherry</b> Sweet, delicate flavor	✓				✓	



**WARNING**

**COMBUSTION BY-PRODUCT PRODUCED WHEN USING THIS PRODUCT CONTAINS CHEMICALS KNOWN TO THE STATE OF CALIFORNIA TO CAUSE BIRTH DEFECTS, OTHER REPRODUCTIVE HARM, OR CANCER.**

**THE MATERIALS USED IN THIS PRODUCT MAY CONTAIN LEAD A CHEMICAL KNOWN TO THE STATE OF CALIFORNIA TO CAUSE BIRTH DEFECTS AND OTHER REPRODUCTIVE HARM.**

**SAFE STORAGE & MAINTENANCE**

- ALWAYS allow unit to cool completely before handling.
- Inspect all hardware in assembled parts for tightness on a regular basis to insure unit is in safe working condition.
- Clean unit, including special surfaces such as cooking grates with mild cleaning agents. Wipe outside of unit with damp rag. DO NOT use oven cleaner.
- ALWAYS cover and store cold unit in a protected area.
- Unit is made of steel and may rust over time. If rusting occurs on outside surfaces, clean area with sand paper or steel wool, then cover with heat resistant paint.
- NEVER USE PAINT ON INSIDE SURFACES OF UNIT.

**HOW TO CLEAN SMOKER**

For cooking grates, water bowl and drip cup use a mild dish detergent. Rinse and dry thoroughly.

For flame disk bowl, clean frequently to remove ash build up, residue and dust.

For the interior and exterior of smoker, simply wipe down with a damp cloth. Do not use a cleaning agent. Make sure to dry thoroughly.

**ALWAYS MAKE SURE UNIT IS COOL  
TO THE TOUCH BEFORE CLEANING AND STORING.**

SMOKING CHART					
ITEM	SIZE	TEMP	WOOD CHIPS	COOK TIME	INTERNAL TEMP
<b>BEEF</b>					
Pot Roast (arm, top, chuck, blade)	4 - 5 lbs (1.8-2.3kgs)	225°F (107°C)	2 cups (0.47l)	3 - 5 hrs	140°F (60°C) Rare 160°F (71°C) Med 170°F (77°C) Well
Brisket	6-10lbs (2.7-4.5kgs)	225°F (107°C)	3 cups (0.83l)	6-8 hrs	170°F (77°C) Well Done
<b>PORK</b>					
Loin Roast (bone in)	4-5lbs (1.8-2.3kgs)	225°F (107°C)	2 cups (0.56l)	5 hrs	165°F (74°C) Well Done
Loin Roast (boneless)	3 - 5 lbs (1.4-2.3kgs)	225°F (107°C)	1 cup (0.24l)	2.5 - 4 hrs	165°F (74°C) Well Done
Spare Ribs	4 - 6 lbs (1.8-2.7kgs)	225°F (107°C)	2 cups (0.56l)	3 - 4.5 hrs	165°F (74°C) Well Done
<b>POULTRY</b>					
Chicken (2 whole)	2 - 3 lbs ea (0.9-1.4kgs)	225°F (107°C)	1 cup (0.24l)	2.5 - 3.5 hrs	165°F (74°C) Well Done
Turkey	11 - 14 lbs (5.0-6.4kgs)	225°F (107°C)	2 cups (0.83l)	6 - 7.5 hrs	165°F (74°C) Well Done
<b>SEAFOOD</b>					
Salmon Steaks	2 - 4 lbs ea (0.9-1.8kgs)	225°F (107°C)	1 cup (0.24l)	1 - 2 hrs	145°F (63°C)
Fish Fillets	2 - 4 lbs ea (0.9-1.8kgs)	225°F (107°C)	1 cup (0.24l)	1 - 2 hrs	145°F (63°C)
Shrimp, Clams, Crab Legs	5 lbs (2.3kgs)	225°F (107°C)	1 cup (0.24l)	1 - 2 hrs	145°F (63°C)
<b>WILD GAME</b>					
Quail, Dove, etc.	12 - 16 birds	225°F (107°C)	1 cup (0.24l)	1.5 - 2.5 hrs	165°F (74°C)
Pheasant, Duck, etc.	5 - 7 lbs (2.3-3.2kgs)	225°F (107°C)	1 cup (0.24l)	2.5 - 3.5 hrs	165°F (74°C)

- When outside temperature is cooler than 65°F (18°C) and/or altitude is above 3,500 feet (1067m), additional cooking time may be required. To insure that meat is completely cooked use a meat thermometer to test internal temperature.
- Opening smoker door during cooking process may extend cooking time due to heat loss.

**RECIPES**

**PORK OR BABY BACK RIBS**

2-4 lbs Pork or Baby Back Ribs  
 ½ tsp Salt  
 ¼ cup Brown Sugar  
 2 ½ tsp Chili Powder  
 1 ½ tsp Ground Cumin  
 2 tsp Cayenne Pepper  
 2 tsp Black Pepper (freshly ground)  
 2 tsp Garlic Powder  
 2 tsp Onion Powder  
 Hickory Chips

Mix ingredients and rub mixture on meat for 2 hours before cooking. Allow meat to reach room temperature.

Cook ribs for 3 hours at 225°F (107°C) in preheated smoker using hickory chips during the first 2 hours.

After 3 hours remove the ribs and wrap in heavy foil. Cook for an additional 1- 1 ½ hours until internal temperature reaches 160°F (71°C).

**HONEY CURED SMOKED SALMON**

1 qt Water  
 ½ tsp Salt  
 ¼ cup Honey  
 ¼ cup Golden Rum  
 ¼ cup Lemon Juice  
 10 Cloves  
 10 Allspice Berries  
 1 Bay Leaf  
 1 Large Fillet of Salmon  
 Hickory or Apple Chips

Combine all of the ingredients except salmon to make a brine. Place the salmon, skin side up, in a baking dish and cover with brining liquid. Allow fish to brine for two hours. Rinse salmon in cold water and pat dry.

Place salmon on a drying rack (or grill rack that you will use to smoke the salmon on) and allow to air dry for at least 1 hour. Smoke the salmon skin side down for about 1-1 ½ hours at 225°F (107°C) and internal temperature reaches 145°F (63°C).

**MAPLE GLAZED HAM**

5-7 lbs Ham Shank or Butt (Fully cooked, bone in)  
 1 ½ cup Maple Syrup  
 1 tsp Ginger  
 ¼ tsp Nutmeg  
 ½ tsp Allspice  
 16 Whole Cloves  
 1 Can Pineapple Slices (canned)  
 1 Jar Maraschino Cherries  
 Hickory or Mesquite Chips

Remove thick skin and trim fat leaving no more than ½" thick covering on ham. Score ham. Combine syrup, ginger, nutmeg, and allspice in a small bowl. Place ham in large dish and baste with syrup mixture. Let ham stand in syrup mixture for 1 or 2 hours basting frequently until at room temperature.

When ready to smoke remove ham from dish and stud with cloves. Place ham in preheated 225°F (107°C) smoker. Cook for about 2-3 hours. Baste with syrup mixture at least 2 times during cooking time. Before last hour of smoking decorate ham with canned pineapple and cherries and baste. Internal temperature of ham should be at 160°F (71°C) when heated.

**SMOKED CORNISH HEN & WILD RICE**

2 Cornish Game Hens  
 ¼ cup Green Onion (chopped)  
 3 tbsp Butter  
 1 cup Wild Rice (cooked)  
 ¼ cup Pecans or Walnuts (chopped)  
 ¼ cup Lime Marmalade  
 ¼ cup Orange Juice  
 Salt  
 Hickory Chips

Rinse and pat dry each hen. Season cavities with salt. Sauté onions in 1 tbsp butter. Stir in rice and chopped nuts.

Stuff hens with rice mixture. Close with skewers or kitchen string. Melt remaining 2 tbsp of butter in small saucepan. Add marmalade and orange juice blending until smooth. Brush hens with marmalade mixture.

Place hens on grate in 225°F (107°C) pre-heated smoker and cook for 2-2 ½ hours until internal temperature reaches 165°F (74°C) . Brush with remaining glaze before serving.

**LIMITED WARRANTY**

Masterbuilt warrants its products to be free from defects in material and workmanship under proper assembly, normal use and recommended care for 90 days from the date of original retail purchase. Masterbuilt warranty does not cover paint finish as it may burn off during normal use. Masterbuilt warranty does not cover rust of the unit. Masterbuilt requires reasonable proof of purchase for warranty claims and suggests that you keep your receipt. Upon the expiration of such warranty, all such liability shall terminate. Within the stated warranty period, Masterbuilt, at its discretion, shall repair or replace defective components free of charge with owner being responsible for shipping. Should Masterbuilt require return of component(s) in question for inspection Masterbuilt will be responsible for shipping charges to return requested item. This warranty excludes property damage sustained due to misuse, abuse, accident, damage arising out of transportation, or damage incurred by commercial use of this product.

This expressed warranty is the sole warranty given by Masterbuilt and is in lieu of all other warranties, expressed or implied including implied warranty, merchantability, or fitness for a particular purpose. Neither Masterbuilt nor the retail establishment selling this product, has authority to make any warranties or to promise remedies in addition to or inconsistent with those stated above. Masterbuilt's maximum liability, in any event, shall not exceed the purchase price of the product paid by the original consumer/ purchaser. Some states do not allow the exclusion or limitation of incidental or consequential damages. In such a case, the above limitations or exclusions may not be applicable.

**California residents only:** Notwithstanding this limitation of warranty, the following specific restrictions apply; if service, repair, or replacement of the product is not commercially practical, the retailer selling the product or Masterbuilt will refund the purchase price paid for the product, less the amount directly attributable to use by the original buyer prior to the discovery of the nonconformity. Owner may take the product to the retail establishment selling this product in order to obtain performance under warranty. This expressed warranty gives you specific legal rights, and you may also have other rights which vary from state to state.



Go Online [www.masterbuilt.com](http://www.masterbuilt.com)  
 or complete and return to  
 Attn: Warranty Registration  
 Masterbuilt Mfg. Inc.  
 1 Masterbuilt Court - Columbus, GA 31907

Name: \_\_\_\_\_ Address : \_\_\_\_\_ City: \_\_\_\_\_

State/Province: \_\_\_\_\_ Postal Code: \_\_\_\_\_ Phone Number: (\_\_\_\_) - \_\_\_\_\_

E-mail Address: \_\_\_\_\_

\*Model Number: \_\_\_\_\_ \*Serial Number: \_\_\_\_\_

Purchase Date: \_\_\_\_ - \_\_\_\_ - \_\_\_\_ Place of Purchase: \_\_\_\_\_

*\*Model Number and Serial Number are located on silver label on back of unit.*



**Masterbuilt Manufacturing, Inc.**  
**1 Masterbuilt Ct.**  
**Columbus, GA 31907**  
**Customer Service 1-800-489-1581**  
**[www.masterbuilt.com](http://www.masterbuilt.com)**