



Models K-30 and K-40 Gas Grill

[click here for Legacy Series
ASSEMBLY, OPERATING
& MAINTENANCE INSTRUCTIONS](#)



PACIFIC GAS SPECIALTIES CORPORATION
P.O. BOX 16097, IRVINE, CALIFORNIA 92623
Phone (949) 757-7723 • FAX (949) 474-5559



Please note: We have made our catalogs, specification sheets, and other materials relating to our line of outdoor cooking products as comprehensive and accurate as possible. We are constantly trying to improve all aspects of our products and therefore, reserve the right to make changes anytime, without notice. Because product improvements may have been made since the time our materials were printed, please check with your Authorized PGS Dealer or Distributor, if you have any specific questions concerning our products. PGS is dedicated to producing the finest leisure gas appliances for the home.

Revised 5/1/2003

TABLE OF CONTENTS

Safety Responsibilities, Warning Symbol	Page 2
Grill Model Identification (Location of Serial Number)	Page 3
Very Important Safety Tips & Warnings	Page 4 - 5
Liquid Propane Gas Safety, Connections, Handling and Storage	Page 6 - 87
Natural Gas Pressure Requirements	Page 9
Definition of Key Terms	Page 9
Required Tools and Nuts, Bolts and Fasteners Part Numbers	Page 10
Drawings of Nuts, Bolts, and Fasteners	Page 10
Part Numbers & Descriptions	Page 11
Parts Breakdown	Pages 12
Check List of Grill Box Contents	Page 13
Permanent Post Installation	Pages 14 - 15
Patio Base/Patio Cart to Grill Head Assembly	Pages 15 - 16
Orifice Engagement	Page 16
Side Shelf Installation	Page 17
Finish Assembly	Page 17
Connecting Your Gas Supply	Page 18
Lighting Your Grill / If Burner Fails to Light	Page 20
Periodic Cleaning	Page 20
Flashback (Spider Fires)	Page 21
Electrode Adjustment	Page 22
Flare Ups	Page 22
Grease Tray Clean Out	Page 22
Gas Grill Conversion	Page 22
Helpful Hints	Page 23
Flame Adjustment	Page 24
Trouble Shooting	See PGS Web Site for Troubleshooting Guide
PGS Accessories	Page 25



SPECIAL ATTENTION:

THIS SYMBOL NOTES SAFETY RELATED ITEMS OR PRODUCT WARNINGS

IT IS YOUR RESPONSIBILITY TO:

ASSEMBLE, INSTALL, LEAK CHECK, CARE AND OPERATE YOUR GAS GRILL. SAVE THESE INSTRUCTIONS FOR FUTURE REFERENCE.

FOR YOUR SAFETY IF YOU SMELL GAS:

1. SHUT OFF GAS TO THE APPLIANCE.
2. EXTINGUISH ANY OPEN FLAME.
3. OPEN LID.
4. IF ODOR CONTINUES, IMMEDIATELY CALL YOUR GAS SUPPLIER.

THIS GAS GRILL IS DESIGNED FOR OUTDOOR USE ONLY

FOR YOUR SAFETY:

DO NOT STORE OR USE GASOLINE OR OTHER FLAMMABLE VAPOR AND LIQUIDS IN THE VICINITY OF THIS APPLIANCE.

THIS GRILL IS NOT INTENDED FOR USE ON A BOAT/HOUSE BOAT OR RECREATION VEHICLE

STORE THE LP GAS (PROPANE) CYLINDER OUTDOORS IN A WELL-VENTILATED SPACE. DO NOT STORE A PROPANE GAS CYLINDER IN DIRECT SUNLIGHT. DO NOT STORE EXTRA CYLINDERS IN CART OR NEAR GRILL. DO NOT STORE THE PROPANE CYLINDER ON ITS SIDE.



Teflon tape or pipe joint compound will be required on all steel pipe connections.

Never use a sealer when your connection is brass to brass. Brass to brass is self-sealing. Using a sealant on a brass to brass connection may cause a leak!

The grill itself is partially assembled, with the burner, venturi, ignitor, collector box, and ignitor lead wire installed. Take your time in assembly. Please read instructions thoroughly before starting assembly.

This manual is based on information available when the manual was printed. Continued improvements in design could cause changes in the grill that may or may not be included herein.

Please consult your authorized PGS dealer if you have any questions concerning assembly, installation or operation of your grill.



The display of a test agency certification seal on the product label indicates that the unit is constructed according to the certified testing agency.

MODEL IDENTIFICATION

Your PGS Grill is identified by a model number and the serial number stamped on the stainless steel collar box located under the control panel and included with your grill head. TAKE THE TIME NOW TO RECORD THE MODEL AND SERIAL NUMBER (located on the collar box) OF YOUR GRILL IN THE SPACE PROVIDED BELOW. Always use both the model number and the serial number when calling or writing PACIFIC GAS SPECIALTIES about your grill. We can be reached at: PO Box 16097, Irvine, CA 92623-6097 (949) 757-7723 FAX (949) 474-5559. Email: pgs@pgscorp.com.

PLEASE RETAIN INSTRUCTIONS FOR FUTURE REFERENCE, AND RETURN THE OWNERS REGISTRATION CARD IMMEDIATELY. RETURN OF WARRANTY CARD INSURES WARRANTY REGISTRATION. MAINTAINING YOUR SALES RECEIPT WILL EXPEDITE WARRANTY CLAIMS.

DATE PURCHASE: _____

DEALERSHIP: _____

CITY, STATE: _____

MODEL NUMBER: _____

TYPE OF GAS: NATURAL GAS ___ PROPANE ___

SERIAL NUMBER _____

The grill must be located no closer than 30" from any combustible surface above, behind or to the sides. The grill should not be located under overhead-unprotected combustible materials.



VERY IMPORTANT SAFETY TIPS AND WARNINGS

PGS is most concerned about the safe use of our product. The following two pages are a summarization of the safety tips found throughout this manual. Please take the time to review them, as they are critical in the enjoyable use of your grill. Improper assembly, neglect, or insufficient care of your PGS gas grill may result in serious bodily injury and/or property damage.



GIVE THIS SYMBOL SPECIAL ATTENTION THROUGHOUT THIS MANUAL. IT NOTES SAFETY RELATED ITEMS OR PRODUCT WARNINGS

Our grills are tested in accordance with ANSI Z21.58a-1999*CGA 1.6a-M99 Standard for Outdoor Gas Cooking Appliances. Check your local building codes for the proper methods of installation. In the absence of local codes, this grill should be installed in compliance with the National Fuel Code No. Z223.1-1995 and the National Electrical Code ANSI/NFPA No. 70-1995. GAS GRILLS ARE NOT AGA DESIGN CERTIFIED OR RECOMMENDED FOR USE ON RECREATIONAL VEHICLES, PORTABLE TRAILERS, BOATS/HOUSE BOATS, OR ANY OTHER MOVING INSTALLATION.

- California Proposition 65 Warning: The burning of gas cooking fuel generates some by-products which are on the list of substances and are known by the State of California to cause cancer or reproductive harm. California law requires that businesses warn consumers of potential exposure to such substances. To minimize exposure to these substances, always operate this gas grill according to the use and care instructions found in this manual. Be certain to provide adequate ventilation when cooking.
- **WARNING:** Do not try to light this appliance without first reading: the "LIGHTING YOUR GRILL" section of this manual found on page 21.
- Do not modify original equipment. Your grill has been designed and engineered to operate safely as outlined in this manual. Only replace components with genuine PGS replacement parts, which are available from your local dealer and/or distributor. Use of non-genuine parts may result in inferior performance and/or safety hazards and will void the warranty.
- Children should not be left alone or unattended in an area where the grill is in operation. We suggest placement of your grill well away from areas where children play. Do not store items that may interest children in or around the grill, in the cart, or in the masonry enclosure. Never allow children to crawl or play inside a masonry enclosure.
- **NEVER STORE ADDITIONAL OR EMPTY PROPANE CYLINDERS IN GRILL CABINET OR AROUND THE GRILL. DO NOT STORE A PROPANE CYLINDER INDOORS OR ON ITS SIDE. NEVER ALLOW A PROPANE CYLINDER TO BE OVERFILLED.** Never use a dented, rusty or damaged propane cylinder. Never replace the safety coupler fittings on the grill with any other connections.
- Never store pool chemicals or other flammable materials in any cabinet below or near the grill. Never allow loose clothing, potholders, synthetic materials, or other flammable materials to come in contact with the grill and/or its parts. Flammable materials could ignite and cause personal injury and/or property damage.
- Never move your gas grill when operating. Never move grill when HOT. Never cover grill when HOT.
- Do not heat up unopened food containers on the grill as a buildup of pressure may cause the container to burst.
- The LP cylinder that you use with your grill should be equipped with an overfill protection device (OPD). If you use a tank exchange system, be sure to exchange this tank for another tank with the same safety system.
- Use an insulated glove when opening and operating the grill. Open grill lid slowly to allow heat and smoke to escape before fully opening.

- Never lean over hot grill surface or look directly into grill when attempting to light. The grill hood must be opened fully when lighting. Be sure that all family members are aware of safe lighting and operating procedures for the grill.
- If a professional installer or dealer installs the grill, be sure that he shows you where your gas supply shut off is located. All gas lines must have a shut off that is readily and easily accessible. If you smell gas, check for gas leaks immediately. Check only with a soap and water solution. Never check for gas leaks with an open flame.
- Never use charcoal, volcanic rock, wood chip materials, or non-PGS briquettes in your grill.
- Keep the optional rotisserie motor and electrical supply cord away from heated casting, cooking grids, other hot parts or water. Store rotisserie motor and parts in a dry place when not in use.
- Never use grill in a windy area and never use the grill during an extremely windy day. Climatic conditions will impact the performance of the grill. In consistently windy conditions, we suggest installing a suitable windbreak.
- Always adhere to the required clearances from combustibles. **THE GRILL IS DESIGNED FOR USE OUTDOORS ONLY**; never operate in garage, buildings, shed, breezeways or other enclosed areas.
- Store your grill in a well-vented area. Remove the LP cylinder, if equipped with one, and store it outdoors in a well-ventilated area away from heat and where children may possibly tamper with it.
- When using the optional side burner kit, use pots that have flat bottoms and are large enough to cover the entire burner. Adjust the flame so that it only heats the bottom of the pot or pan to avoid the possible lighting of clothing. Position handle in a way that it does not conflict with the opening and closing of grill lid. You cannot operate your side burner kit and rotisserie motor simultaneously.
- Grease is extremely flammable. Let hot grease cool down before attempting to handle or dispose. Please clean out your grease tray or grease can on a regular basis.
- Never cover cooking grid with a material that will trap heat beneath cooking grids, such as large pans or aluminum foil. Heat reflected below may cause damage to rock grates, burners, gas valve assembly and possibly to gas train. You need only to "Pre-Heat" your grill five to seven minutes before cooking. You do not need to "Burn-Off" your gas grill for extended times after use.
- Spiders and other small insects can build nests or webs in the burners of your PGS grill, which will cause gas to flow out from the front of the burner tubes. This can cause a fire to burn behind your control panel, thereby damaging your grill and makes the grill unsafe to operate. Inspect your grill twice a year or immediately when symptoms appear. See "FLASHBACK" on page 22.
- Please refer to specific sections of this manual (see Table of Contents) if you have questions regarding different types of fuels, lighting, or trouble-shooting. If you have questions that are not answered in this manual, please call your local dealer.
- The grill must be located no closer than 30" from any combustible surface above, behind or to the sides. The grill should not be located under overhead-unprotected combustible materials.
- Keep the area around the grill clear of combustible materials, flammable vapors or liquids such as gasoline. The grill surfaces become very hot during use. Keep children and pets away. Use hot pads or oven mitts.

GAS

Both natural gas (NG) and propane gas (LP) have a long history of safe use when simple rules are followed. If not, there is danger of fire or explosion.

Check Local Codes. Consult your local LP dealer or Natural Gas company listed in your local directory for recommended installation procedures and regulations. In the absence of local codes, installation must conform with the National Fuel Gas Code, ANSI Z21.58a-1999*CGA 1.62-M99.



NEVER USE NATURAL GAS IN A UNIT DESIGNED FOR LIQUID PROPANE OR THE REVERSE. IF YOU WISH TO CONVERT YOUR GRILL FROM ONE TYPE OF GAS TO THE OTHER, PLEASE CONTACT YOUR LOCAL DEALER OR DISTRIBUTOR.

Never connect an unregulated propane gas cylinder or unregulated natural gas to your gas grill (Note: most homes equipped with natural gas have a regulator near the gas meter.

USER SAFETY INFORMATION OF PROPANE MODELS

Your PGS grill is designed to operate on Propane Gas regulated at a gas pressure of 11" water column (W.C.) (2.7kPa). If you are hooking your grill into "System LP" which fuels your home, please be certain that you are at this pressure.



Operating your grill at pressure higher or lower than recommended may damage the grill or result in a hazard or poor performance.

A regulator adjusted to this pressure must be installed in the gas supply line before the grill is connected to the propane source. PGS propane gas grills include an 11" W.C. regulator and a "TYPE II" Cylinder Connection Device. This system complies with the specifications and requirements of ANSI Z21.58a-1999*CGA 1.62-M99 standards. This system can only be used with a "quick couple" type of tank. Our regulated hoses include an excess flow safety system that will limit the flow of gas to your grill in the event of leaking gas or a damaged hose.

PLEASE NOTE. In the event that you inadvertently have the valves of your grill turned to the "ON" position, and then open the valve on top of your tank, the excess flow device will activate and shut off the flow of gas. If this

should occur, turn the valves to the "OFF" position on your grill head, then the valve on the tank. Wait two minutes and then open the valve on the tank BEFORE turning the valves of your grill head. Always turn on the valve at the top of your tank and then the valves to your grill head to the "ON" position.

The safety system detailed above has been incorporated into your PGS gas grill to provide you and your family the maximum in safety when operating the grill.



PLEASE DO NOT CHANGE THE LP HOSE OR USE WITH A STANDARD 20 LB. P.O.L. CYLINDER OR TANK EQUIPPED WITH A "QCCI" FITTING.



TURN VALVE THAT IS LOCATED AT THE TOP OF TANK TO "OFF" WHEN GRILL IS NOT IN USE.

DO NOT CONNECT THE GRILL TO A PROPANE GAS CYLINDER GREATER THAN 20 LB. CAPACITY.

Check with your LP gas utility or your PGS dealer for a local source for tanks that accommodate a "TYPE II" Tank nipple.

PROPANE CYLINDER FILLING

Federal Law requires any tank used for a gas grill must include an overfill protection device. If you are uncertain whether your tank complies, check with selling dealer. A "TYPE II" FILL ADAPTER has been supplied with your PGS LP cart that can be used by any LP filling station in the event they do not have the proper tank filling adapter. Please do not allow a fueling station operator to change or modify this safety system. If for any reason the fueling station is not familiar with this adapter, please find another fueling station.

PUT THE "TYPE II" FILL ADAPTER IN A SAFE PLACE SO THAT IT IS AVAILABLE WHEN NEEDED

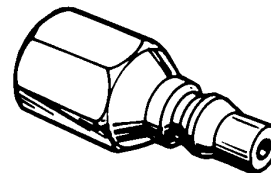

TYPE II
FILL ADAPTER

When the hose is disconnected from the quick coupler on the tank, the flow of gas is safely shut off. You must still shut off the main tank valve located at the top of the tank when transporting your tank or when the unit is not in use.

PROPANE CYLINDER FILLING AND HANDLING SAFETY TIPS

- Be certain tank is equipped with an overfill protection device.
- Do not modify hose or LP fittings. Contact a local dealer or distributor if tank, hose or fittings need replacement.
- If it is evident there is excessive abrasion or wear, or the hose is cut, it must be replaced prior to the grill being operated. Please see your local PGS dealer/distributor or call PGS for an exact replacement.
- Store propane tank outdoors in a cool, well-ventilated area. Never store extra tanks in, on, or around your grill.
- Turn off tank when not in use.
- Transport tanks upright ONLY.
- Never allow a tank to be overfilled. 100% full tank holds only 4.5 gallons of propane.
- Inspect your grill cabinet often to ensure that ventilation openings in sides and back of pedestal are free from debris and have proper air circulation.
- Never paint LP cylinder a dark color. This may cause OVERHEATING. Do not apply heat directly to tank.
- LP Gas is stored under high pressure and must be handled with care. Do not handle a tank roughly.
- You must use the "TYPE II" fill adapter that was provided with your propane grill. If unable to locate, see your local dealer, distributor or PGS.
- Be sure your LP gas dealer checks the cylinder with a soapy solution for leaks after filling.
- Do not turn gas valve on unless connection between regulator and coupler is complete.
- Storage of your gas grill indoors is permissible only if the cylinder is disconnected, removed from grill and cylinder stored outdoors.



BEFORE ATTEMPTING TO LIGHT GRILL, BE CERTAIN THE GAS VALVE KNOBS ARE IN THE OFF POSITION. TURN TANK VALVE ON BY TURNING KNOB ON TOP OF TANK, COUNTER CLOCKWISE. CHECK ALL CONNECTIONS WITH A SOLUTION OF 50% LIQUID SOAP, 50% WATER. SOLUTION CAN BE SPRAYED ON WITH A SPRAY BOTTLE OR PAINTED ON ALL CONNECTIONS WITH A BRUSH. IF BUBBLES APPEAR THERE IS A LEAK, TURN OFF GAS, TIGHTEN FITTINGS AND REPEAT THIS CHECK.

The cylinder must be provided with a shut-off valve terminating in an LP-gas supply cylinder, valve outlet specified, as applicable, for Connection No. 510 in the Standard for Compressed Gas Cylinder Valve Outlet

and Inlet Connections, ANSI/CGA-V-1, or Connection No. 600 in the Compressed Gas Association's Limited Standard Cylinder Valve Outlet Connection for Propane Small Valve Series or a combination LP-gas cylinder valve and quick-disconnect assembly complying with 1.5.5-c and a safety relief device making a direct connection with the vapor space of the cylinder.

The cylinder supply system must be arranged for vapor withdrawal and must include a collar to protect the cylinder valve.

****Special Note**** All new tanks are filled with air, not propane. Air must be purged before the tank is filled. When purchasing an LP gas tank, be certain it meets all standards, and allow only a qualified LP-gas dealer to fill the propane gas cylinder.

PROPANE GAS CYLINDER



DISCONNECTED CYLINDER MUST NOT BE STORED IN A BUILDING, GARAGE OR ANY OTHER ENCLOSED AREA. BEFORE LIGHTING YOUR GRILL, INSPECT THE HOSE TO ENSURE THAT IT IS IN TACT AND THERE ARE NO LEAKS.

All LP-gas cylinders used with this grill shall be approximately 12" in diameter and about 18" in height. The maximum fuel capacity must be 20 lbs. of propane (47.7 lbs. nominal water capacity or 4.5 gallons). DO NOT connect your grill to a propane gas cylinder that exceeds this capacity.

All propane-gas cylinders used with the grill must be constructed and marked in accordance with the specifications for propane-gas cylinders of the U.S. Department of Transportation (DOT). In Canada, gas cylinders must meet CTC specs. Federal Law requires any tank used for a gas grill must include an overfill protection device.

All refillable propane-gas cylinders used with the gas grill must be inspected at every filling and must be re-qualified by a licensed LP-gas cylinder filler in accordance with DOT (US) or CTC (Canadian) requirements for LP-cylinders.

LP-Gas Tank Specifications:

Weight (filled)	40 lbs.	(18.14 kg)
Capacity	4.5 gallons	
Diameter (outside)	12 1/8"	(30.8 cm)
Height	18"	(45.7 cm)
Connection	TYPE II Couple Safe	

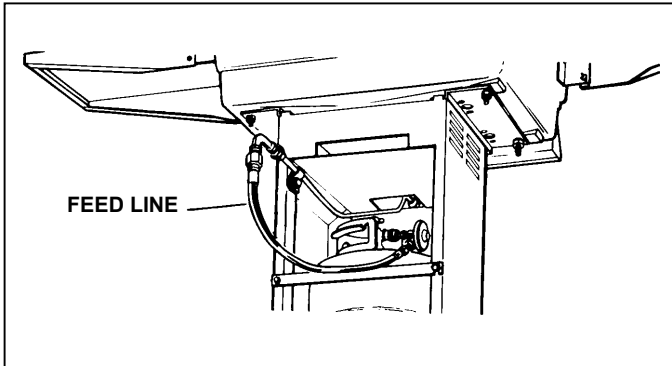

LP Tank, Hose and Feedline Assembly

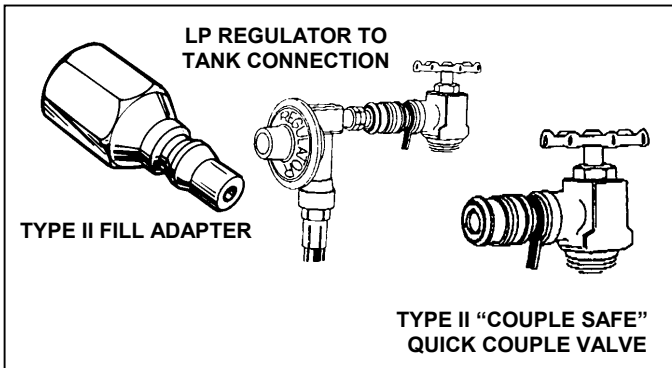

TYPE II LP Connections

NATURAL GAS MODELS

Your PGS gas grill has been designed and produced for outdoor use only! Every gas-burning appliance produces carbon monoxide and should not be allowed to accumulate in confined areas. **DO NOT OPERATE YOUR PGS GAS GRILL INSIDE A HOME, GARAGE, RECREATIONAL VEHICLE, BOAT/HOUSE BOAT, OR ANY OTHER ENCLOSED AREA.**

When choosing a location for your grill, you must locate it at least 30" away from any combustible material and out of traffic paths. The grill and its individual shutoff valve must be disconnected from the gas supply piping system during any pressure testing of that system at test pressures in excess of 1/2 psig (3.5kPa).

The grill must be isolated from the gas by closing its valves during any pressure testing of the gas supply piping system at test pressures equal to or less than 1/2 psig (3.5kPa).

DEFINITION OF KEY TERMS

GRILL HEAD: Entire BBQ grill (lid & pit) that can be mounted on a variety of options.

GRILL MOUNT: Supports gas grill head, can be a post mount, pedestal mount (stationary or mobile) or built in frame inserted in a masonry enclosure.

GRILL UPPER CASTING: Top (lid) of gas grill head, made of aluminum and powder coated black.

GRILL LOWER CASTING: Bottom (pit) of gas grill head made of aluminum and powder coated black.

BASE: Stationary or designed to be used with wheels made of aluminum and powder coated black.

RACK: Warming area made of stainless steel and removable.

COOKING GRIDS: Area most used for grilling, with variably spaced grid tines for flexibility.

ROCK GRATES: Solid stainless steel plates with square holes in them for heat convection.

MOON ROK II: The highest quality grill rock for great BBQ flavor and flare control.

COLLAR BOX: Stainless steel box between grill mount and grill head.

IGNITOR MODULE: Battery powered ignition for instant spark.

VALVE: Device used to control amount of gas (and heat) grill produces.

ORIFICES: Openings at end of valve that restrict amount of gas going to BBQ.

VENTURI: Banana shaped tube that allows gas to flow from the valve to the burner.

FEEDLINE: Aluminum gas line from back to grill mount to bottom of valve. Used only on models that include pedestal.

HINGE PINS AND COTTER PINS: Hinge pin goes through lower and upper casting with cotter pins permanently holding.

GASKET: Insulator between pedestal and base.

WATER COLUMN (W.C.): A measurement of gas pressure.

YOU WILL NEED THE FOLLOWING TOOLS TO ASSEMBLE YOUR PGS GAS GRILL:

- 1 - Mallet or Hammer
- 2 - 6" Adjustable Wrenches
- 50% Soap and Water Solution

- 1 - Med. Phillips Head Screw Driver
- 1 - Small Roll of Teflon Tape (Natural Gas Only)
- 1 - Spray bottle or brush

Having these additional tools on hand will make assembly easier:

1 - 1/2" Socket and Drive

















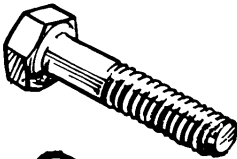



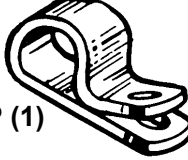

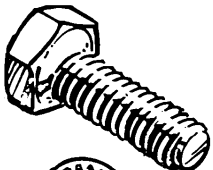
1 - 7/16" Socket and Drive

PGS NUTS, BOLTS AND FASTENERS FOR IDENTIFICATION

(PLEASE NOTE: NOT ALL OPTIONS REQUIRE QTY. BELOW)

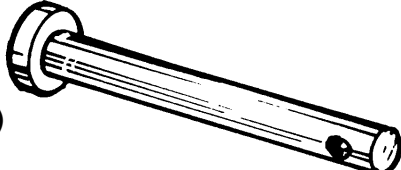
REF #	DESCRIPTION	QTY.	PART #	USED FOR:
1	5/16 X 3/4" BOLT	6	101030	Base to Pedestal
2	5/16" WASHER	6	101260	Base to Pedestal
3	5/16" LOCK WASHER	6	101280	Base to Pedestal
4	5/16" NUT	6	101130	Base to Pedestal
5	1/4 X 20 X 1-1/4" BOLT	4	101010	Head to Pedestal Assembly
6	CAGE NUT	4	101220	Head to Pedestal Assembly
7	1/4" WASHER	4	101240	Head to Pedestal Assembly
8	1/4" LOCK WASHER	4	101270	Head to Pedestal Assembly
9	3/8 X 16 X 1" BOLT	2	101035	Side Handle Bolt
10	3/8" STAR WASHER	2	101200	Side Handle Washer
11	HINGE PIN	2	101050	Upper Casting to Lower Casting
12	COTTER PIN	2	101040	Through Hinge Pin to Secure Top Casting
13	8 x 1/2" SHEET METAL SCREW	2	101150	Collar Box to Pedestal / Control Panel
14	TINNERMAN CLIP	2	101210	Collar Box to Pedestal / Control Panel*
*NOTE: 2 ADDITIONAL SCREWS/TINNERMAN CLIPS ARE PRE-ATTACHED TO THE BOTTOM OF THE CONTROL PANEL				
15	FEEDLINE MOUNTING CLIP	1	100340	To Secure Feedline (Pre-mounted on Feedline)
16	10-32 S.S. MACHINE SCREW	3	101160	1 for Feedline Mounting Clip, 2 for Tank Strap
17	1/4 X 20 X 3/4" BOLT	4	101020	Side Shelf Assembly
18	1/4" WASHER	4	101240	Side Shelf Assembly
19	1/4" LOCK WASHER	4	101270	Side Shelf Assembly
20	1/4" NUT	4	101140	Side Shelf Assembly
21	AXLE CAP	2	100160	Wheel Hubs
22	1/4 X 20 X 3/4" BOLT	3	101015	Permanent Post Head to Post Bolt (if purchased 48" Permanent Post)
23	1/4 X 20 NUT w/LOCK WASHER	3	101100	Nut for above (if purchased 48" Permanent Post)

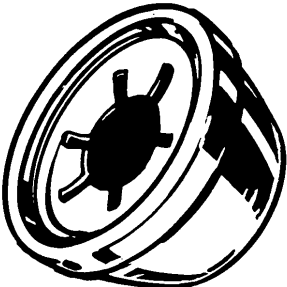
DRAWINGS OF NUTS & BOLTS AND FASTENERS

REF # DESCRIPTION (QUANTITY)	REF # DESCRIPTION (QUANTITY)
<p style="text-align: center;">BASE TO PEDESTAL</p> <p>1. 5/16 X 3/4" BOLT (6) </p> <p>2. 5/16" WASHER (6) </p> <p>3. 5/16" LOCK WASHER (6) </p> <p>4. 5/16" NUT (6) </p>	<p style="text-align: center;">COLLAR BOX TO PEDESTAL AND CONTROL PANEL</p> <p>13. 8 X 1/2" SHEET METAL SCREW (2) </p> <p>14. TINNEMAN CLIP (2) </p>
<p style="text-align: center;">HEAD TO PEDESTAL ASSEMBLY</p> <p>5. 1/4 X 20 X 1-1/4" BOLT (4) </p> <p>6. CAGE NUT (4) </p> <p>7. 1/4" WASHER (4) </p> <p>8. 1/4" LOCK WASHER (4) </p>	<p style="text-align: center;">FEEDLINE</p> <p>15. FEEDLINE MOUNTING CLIP (1) </p> <p>16. 10-32 S.S. MACHINE SCREW (3) </p>
<p style="text-align: center;">SIDE HANDLE</p> <p>9. 3/8 X 16 X 1" BOLT (2) </p> <p>10. 3/8" STAR WASHER (2) </p>	<p style="text-align: center;">SIDE SHELF ASSEMBLY</p> <p>17. 1/4 X 20 X 3/4" BOLT (4) </p> <p>18. 1/4" WASHER (4) </p> <p>19. 1/4" LOCK WASHER (4) </p> <p>20. 1/4" NUT (4) </p>
<p style="text-align: center;">UPPER CASTING TO LOWER CASTING</p> <p>11. HINGE PIN (2) </p> <p>12. HAIR COTTER PIN (2) </p>	<p style="text-align: center;">WHEEL HUB</p> <p>21. AXLE CAP (2) </p> <p>22. 1/4 20 X 3/4" BOLT (3) </p> <p>23. 1/4 20 NUT w/LOCK WASHER (3) </p>

PART NUMBERS AND DESCRIPTIONS

PLEASE NOTE: ALL PARTS MAY NOT COME WITH ALL MOUNTING OPTIONS

REF #	DESCRIPTION	QTY	MODEL K-40	MODEL K-30
1	UPPER GRILL CASTING	1	140125	130125
2	LOWER GRILL CASTING	1	140120	130120
3	WARMING RACK	1	140200	130200
4	COOKING GRID	2	140140	130140
5	ROCK GRATES (Not shown)	2	140170	130170
6	BURNER ASSEMBLY	1	140105	130110
7	VALVE ASSEMBLY FOR NATURAL GAS (Not shown)	1	140190	130190
7	VALVE ASSEMBLY FOR LIQUID PROPANE GAS (Not shown)	1	140180	130180
8	STAINLESS STEEL CONTROL PANEL	1	140130	130130
9	SIDE HANDLES	2	100520	
10	BOLT & STAR WASHER F/HANDLE	2	101035 / 101200	
11	MOON ROK II – CERAMIC ROCK	1	MOON ROK II	
12	CONTROL KNOBS	2	100240	
13	IGNITOR MODULE	1	100280	
14	IGNITOR WIRE (For K-30 Only) (Not shown)	1	100680	
15	COLLAR BOX	1	100220	
16	STAINLESS STEEL PEDESTAL	1	100540	
17	BLACK PEDESTAL	1	100550	
18	SIDE SHELF W/BRACKET	1	S.S. SHELF	
19	ALUMINUM BASE FOR PORTABLE CART	1	100130	
20	ALUMINUM BASE FOR PATIO BASE (Flat)	1	100120	
21	AXLE CAPS	2	100160	
22	1/2"X 21.5" SOLID STEEL AXLE	1	100140	
23	POLY WHEEL	2	100630	
24	16" LP HOSE & REGULATOR - TYPE 1	1	100500	
25	12" NATURAL GAS HOSE KIT	1	100480	
26	FEEDLINE WITH 3/8" FLR FITTINGS	1	100320	
27	FEEDLINE MOUNTING CLIP	1	100340	
28	TANK STRAP – STAINLESS STEEL	1	100600	
28	TANK STRAP – BLACK	1	100590	
29	TYPE II FILL ADAPTER	1	100370	
30	COLLECTOR BOX FOR IGNITOR (K-30 only)	1	100230	
31	2-PIECE GASKET FOR BASE TO PEDESTAL	1	100400	
32	3/8" FLARE X 3/8" FLARE ELBOW	1	100310	
33	48" POST FOR PERMANENT INSTALLATION	1	48PP	
34	28" FLEXIBLE FEEDLINE FOR PERMANENT POST	1	100365	
35	STIFFENING BRACKET SET FOR PERMANENT POST	1	100040	
36	K-40 ULTIMA BURNER IGNITION SYSTEM (Includes electrode/collector box/wire)	1	140105	
37	GREASE TRAY	1	100420 (Black)	100430 (S.S.)
38	VENTURI BRUSH (Not shown-see page 22)	1	100620	
39	NIPPLE (Only for LP Hose & Regulator Assembly)	1	100535	
ACCESSORIES FOR PGS GAS GRILLS (NOT SHOWN)				
	INFRA-BROIL REAR BURNER KIT		IBK UNIV	
	SIDE BURNER KIT (SPECIFY LP OR NG)		SBK	
	COVER FOR 0 SHELF OR FOLD DOWN SHELF		COVER0S	
	COVER FOR 1 SHELF		COVER1S	
	COVER FOR 2 SHELVES		COVER2S	
	SET OF 6 SHISH KA BOBS		SHISH	
	STAINLESS STEEL CLEANER		SSCII	
	ROTISSERIE KIT		ROTIIS	
	CADDE FOR BARBECUE TOOLS		CADDE	

PGS GAS GRILL PARTS BREAKDOWN

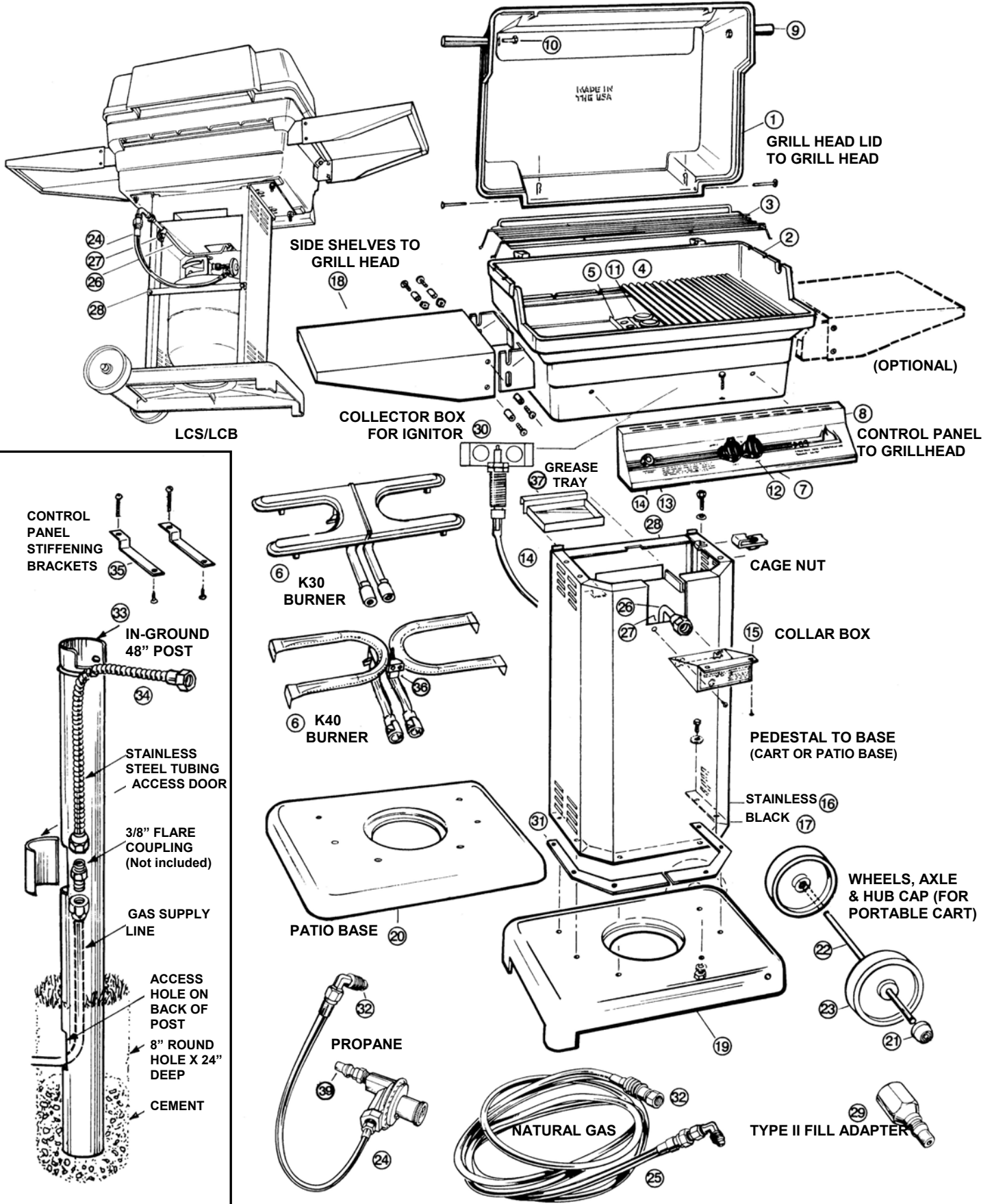

CHECK LIST OF GRILL BOX CONTENTS

1. REMOVE ALL CONTENTS FROM BASE AND PEDESTAL OR 48" POST BOX. YOU WILL FIND:

IF YOU PURCHASED AN LC (Liquid Propane Cart) YOU WILL FIND:

Qty 1 Cast Alum. Base with feet & holes for axle
Qty 2 Wheels
Qty 2 Axle push nuts
Qty 1 Solid 21 1/2" Long by 1/2" diameter axle
Qty 1 16" or 20" hose, LP Regulator/Assembly
Qty 1 3/8" by 3/8" flare brass elbow
Qty 1 Stainless Steel tank strap
Qty 1 TYPE II LP fill adapter

IF YOU PURCHASED A NC (Natural Gas Cart) BASE YOU WILL FIND:

Qty 1 Cast Alum. Base with feet & holes for axle
Qty 2 Wheels
Qty 2 Axle push nuts
Qty 1 Solid 21 1/2" long by 1/2" axle
Qty 1 12 foot hose and coupler assembly
Qty 1 3/8" by 3/8" brass elbow

IF YOU PURCHASED A NB (Natural Gas Base) YOU WILL FIND ONLY THE BASE IN THE BOX.

IF YOU PURCHASED A "S" PED (Stainless Steel Pedestal Kit) YOU WILL FIND:

Qty 1 Stainless Steel Pedestal

Within the Shelf Box you will find:

Qty 2 Pedestal to Base Gaskets
Qty 1 Grease Tray
Qty 1 Feed Line with 3/8" Female Flare Fitting
Qty 1 Feed Line mounting clip
Qty 1 Parts Bag for Grill Head to Pedestal/Base:
Qty 6 5/16" X 3/4" S.S. hex bolts
Qty 6 5/16" S.S. nuts
Qty 6 5/16" S.S. washers
Qty 6 5/16" S.S. lock washers
Qty 4 1/4" X 20 X 1 1/4" long S.S. bolts
Qty 4 1/4" S.S. washers
Qty 4 1/4" S.S. lock washers
Qty 4 Cage Nuts
Qty 2 #8 X 1/2" S.S. screws
Qty 2 Tinnerman Clips
Qty 3 10-32 S.S. screws
Qty 1 Side Shelf W/Brackets & Parts Bag
Qty 1 Left Hand Shelf Bracket
Qty 1 Right Hand Shelf Bracket
Qty 4 1/4" X 20 X 3/4" hex bolt
Qty 4 1/4" lock washers
Qty 4 1/4" X 20 hex nut
Qty 4 10-32 hex nuts

IF YOU PURCHASED A "B" PED (Black Pedestal Kit) YOU WILL FIND

All parts listed above in the "S" Ped box except pedestal and:

Qty 1 Black Galvanized Steel Pedestal

IF YOU PURCHASED A 48" PERMANENT POST (MODEL 48PP) FOR IN GROUND MOUNTING YOU WILL FIND:

Qty 1 48" black extruded alum. ground post
Qty 3 1/4" 20 kep nuts
Qty 3 1/4" 20 X 3/4" hex head bolt
Qty 1 28" flexible steel feed line
Qty 1 Wire grease cup holder
Qty 1 Bag of control panel securing brackets with screws, bolts, Tinnerman clips and nuts.

NOTE: SIDE SHELVES ARE OPTIONAL FOR PERMANENT POST MODEL. IF DESIRED, PLEASE PURCHASE PART #: S.S. SHELF. GRILL CAN ACCOMMODATE UP TO TWO SIDE SHELF KITS.

2. REMOVE ALL CONTENTS FROM THE GRILL HEAD BOX

Qty 1 Aluminum grill upper casting
Qty 1 Aluminum grill lower casting with burner, collector box and ignitor electrode with wire attached
Qty 1 Warming rack
Qty 2 "Vari Grid" 304 S.S. Cooking Grids
Qty 2 "Flare Guard" 304 S.S. Rock Grates
Qty 1 Box of ceramic Moon Rok II
Qty 1 Stainless Steel Control Panel with valve assembly attached, as well as two mounting bolts with four nuts attached (located underneath the control panel).
Qty 1 Collar box with AGA/CGA rating sticker, Model # and PGS Serial Number.
Qty 1 "Sure Start" Electronic Ignition Module that attaches to control panel w/black plastic retaining ring and red rubber weather cap.
Qty 1 AA Battery
Qty 1 Venturi Cleaning Brush
Qty 2 Control Valve Knobs

Within the Side Handle parts bag you will find:

Qty 2 "Stay Cool" side handles
Qty 2 Hood side handle bolts
Qty 2 Star Washers
Qty 2 Hinge pins & Cotter Pins

Be sure that the fuel source designated on your grill head is the same as that of the support system.

⚠ DO NOT USE A GRILL HEAD EQUIPPED FOR NATURAL GAS WITH LP GAS OR THE OPPOSITE.

Maximum inlet pressure from System LP cannot exceed 11" W.C. The proper orifices and valving for each gas is contained in the grill head. Maximum pressure for Natural Gas is 7" W.C.

3. VERIFY ALL PARTS. IF YOU ARE MISSING ANY PARTS, PLEASE CONTACT YOUR PGS DEALER.

4. REMOVE PROTECTIVE FILM FROM ALL STAINLESS STEEL COMPONENTS (Be careful not to scratch stainless steel parts).

PERMANENT POST (IN GROUND) MOUNTING

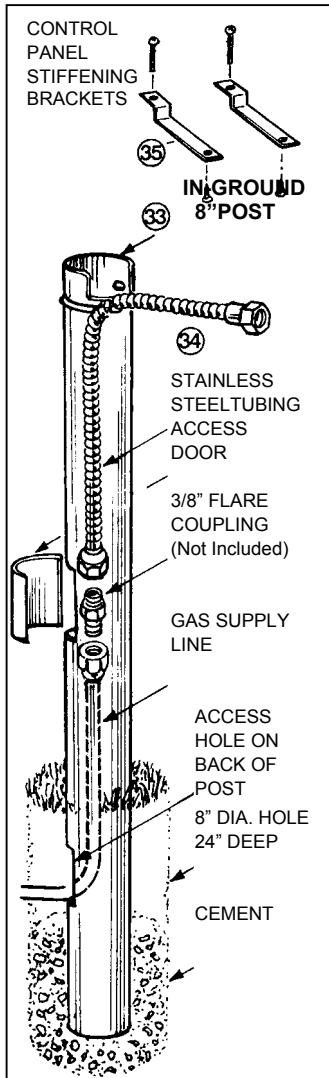

Your PGS permanent post is made of aluminum. Although aluminum is extremely resistant to outdoor conditions, caution should be taken to protect against soil conditions in your area. Please consult your dealer for further information.

PLEASE NOTE: THE GRILL HEAD IS NOT TO BE FASTENED TO THE 48" POST UNTIL THE POST IS CEMENTED INTO THE GROUND.

1. A gas supply line should be trenched at least 18" below the ground surface to prevent damage from digging. You must have a supply line regulated to 7" W.C. and have a master shut off valve.

PLEASE CHECK WITH LOCAL CODES FOR LOCAL REGULATIONS. 2. Dig a posthole 8" in diameter and two feet deep. Locate the hole so

the grill will be at least 30" away from any combustible object or surface: above, back, left or right. The

access hole is on the BACK of the post and the notches at the top are on the front of the post. Center the post in the hole and plumb it with a level. Pour cement up to the gas line access hole.

3. Run the gas supply line into the post making a 90-degree bend to reach the access door. Connect steel connector supplied with post to gas supply line.

4. Remove the grill burner from the lower grill casting by disengaging the burner from the lower casting.

5. Carefully set grill head in place. Pass three 1/4" X 20" X 3/4" bolts provided in permanent post box through grill head cast collar and then through holes in permanent post. Attach three 1/4" X 20" keps nuts. Then attach the grease cup holder at this time on rear center bolt. Securely tighten all nuts and bolts (see illustration below). Insert an empty soup can in grease cup holder to catch juices.

K-30 BURNER

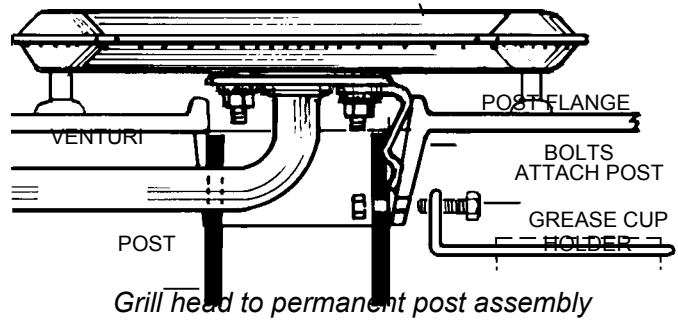

REMOVE PROTECTIVE FILM FROM CONTROL PANEL, COLLAR BOX AND ROCK GRATES

6. You will note that the bolts already attached to the control panel have two nuts on each of them. Remove the plastic thread protectors and discard. Remove the top nut on each bolt and make certain lower nut is securely tightened against control panel.

7. Attach gas line from permanent post to valve assembly. BE CERTAIN NOT TO CROSS THREAD. Hand-tighten only at this time.

8. Insert 3/4" bolts (Pre-assembled on control panel) through grill head, attach nuts and securely tighten. Tighten gas line to valve assembly.

9. TEST ALL FITTINGS FOR LEAKS. BEFORE ATTEMPTING TO LIGHT GRILL, BE CERTAIN BOTH CONTROL PANEL VALVES ARE IN THE OFF POSITION. TURN GAS SUPPLY ON AT THE SOURCE AND CHECK ALL CONNECTIONS WITH A SOLUTION OF 50% LIQUID SOAP, 50% WATER. SOLUTION CAN BE SPRAYED ON WITH A SPRAY BOTTLE OR PAINTED ON ALL CONNECTIONS WITH A BRUSH. IF BUBBLES APPEAR, TURN OFF GAS, TIGHTEN FITTINGS AND TRY AGAIN. NEVER CHECK FOR LEAKS WITH A MATCH OR FLAME.



10. Place Tinnerman clips, provided in stiffening bracket bag, in both pre-drilled holes on lower side of control panel (approximately 2" in from outside edges). Put #10 screw through control panel stiffener then into Tinnerman clips (see illustration below).

11. Lightly push down on front edge of control panel, while pushing machine screw through hole in bottom of casting, through stiffening bracket. Attach lock washer and nut. Repeat on other side of control panel (see illustration below).

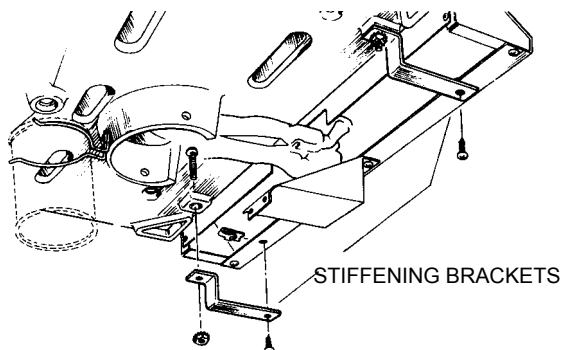

Stiffening Bracket Attached to Lower Casting

See the FINISH ASSEMBLY section on page 18 to finish setting up your grill. Attaching Collar Box on the permanent post is optional, if you choose to attach, please note that there is no lower member to attach collar box.

PATIO BASE/CART TO GRILL HEAD ASSEMBLY

IF YOU PURCHASED A NATURAL FLAT BASE PROCEED TO STEP 2.

1. If the model you purchased is a PORTABLE CART (LP or NAT), attach axle cap to one end of axle. Put one wheel on axle. Push axle and wheel assembly through hole in sidewall of the base then through other side of the base (see Fig. 1). Stand pedestal assembly on edge with installed wheel square on the ground and slide the other wheel over axle. Carefully drive the other axle cap onto end of axle. Set aside.



Figure 1 Wheel Assembly

2. Position pedestal with notched edge down. Place the 2-piece rubber gasket and align with holes in pedestal (see Fig. 2). Set aluminum base, inverted, lining up holes with previously positioned gasket and pedestal. Insert the 6 - 5/16" X 3/4" bolts with washers up through pedestal into base securing with lock washer and nut (see Fig. 3). Turn pedestal and base assembly right side up.



Figure 2 Rubber Gaskets on Bottom of Pedestal



Figure 3 Attaching Pedestal to Base

3. Clip Cage Nuts to top of pedestal matching holes (See Fig. 4).

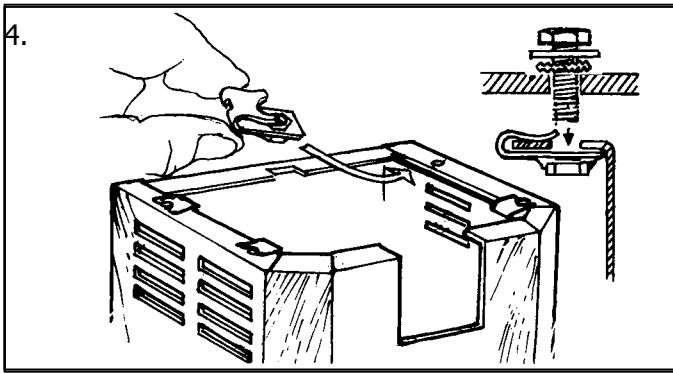

Figure 4 Installation of Cage Nuts on Pedestal

4. Place lower grill casting on top of pedestal lining up four bolt holes (located just above air vents) with cage nuts just installed (see Fig. 5). Then insert the 4-1/4" X 20" X 1 1/4" hex bolt each with a 1/4" flat washer and 1/4" lock washer. When all four are in place, tighten bolts securely.

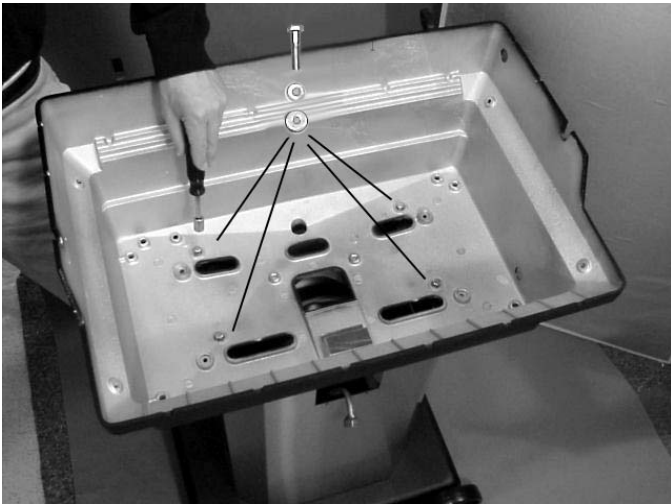
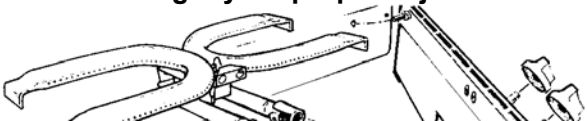

Figure 5 Placement Holes in Lower Grill Casting for Hex Bolts

5. Install burner assembly into lower casting by inserting venturi tubes through lower casting (see Fig. 6). The burner has a spring clip to secure the burner in the casting. Be sure that the burner "snaps" into position.

6. Attach control panel to grill head. You will note that both of the bolts attached to the control panel have two nuts on them. Remove plastic thread protectors at the end of bolts and discard. Remove the top nut leaving the remaining nut (closest to the back of the control panel) to act as a spacer. Insert 3/4" bolts (pre-assembled on control panel) through holes on front of lower casting. Be sure you line up the venturis over the valve stems protruding from the back of the control panel (see Orifice Engagement). Attach nuts and leave slightly loose at this time to allow for adjustment (see Fig. 6). **If the venturis do not align over the valve stems properly, they can be rotated slightly for proper adjustment.**



K-40

Figure 6 Control Panel/ Feedline to Valve Connection

ORIFICE ENGAGEMENT

At the end of each valve there is a tiny gas opening known as an orifice. Gas exits the orifice and enters the venturis where it mixes with air. The proper mixture of gas and air produces a clean blue flame with slight yellow tips from the burner.

BE CERTAIN THAT ORIFICES ARE ENGAGED INTO THE BURNER VENTURIS (see Fig. 7). Proper orifice engagement should be 1/4" to 3/8" into the venturis.



FAILURE TO PROPERLY ALIGN THIS CONNECTION MAY CAUSE A FIRE AND RESULT IN DAMAGE TO YOUR GRILL.

K-30

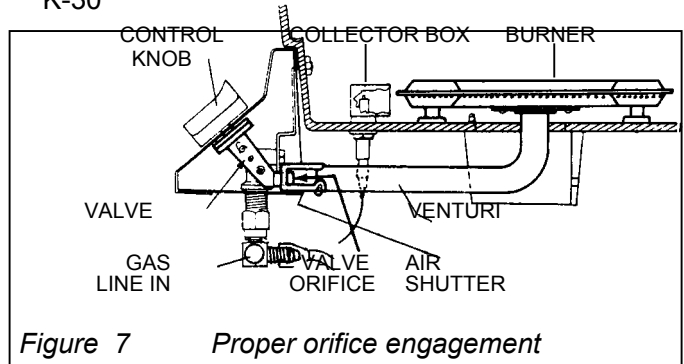

Figure 7 Proper orifice engagement

7. Insert feed line through the rear of the pedestal with the bent end coming through to the front of the pedestal. Attach 3/8" female brass flare nut to valve assembly.

NOTE: BE CAREFUL NOT TO CROSS THREAD THIS FITTING. This is a brass to brass flared fitting, IT WILL NOT REQUIRE ADDED SEALANT OR TEFLON TAPE. Once properly in place, tighten both control panel and feedline securely.

THIS CONNECTION WILL REQUIRE LEAK CHECK UPON ASSEMBLY COMPLETION. (see Fig. 18).

8. Attach feed line mounting clip to pedestal using #8 X 1/2" S.S. machine screw. BE SURE TO ALIGN SCREW TO AVOID STRIPPING THREADED NUTSERT.

9. Remove "Sure Start" Ignitor module from the underside of control panel by unscrewing black ring. Remove rear cover of module and insert a fresh AA alkaline battery into unit (included). Plug the end of the ignitor wire lead to the electronic ignitor module. NOTE: On the K-40, the wire is fed through the lower casting and connects to the electrode lead, which is attached to the burner. On the K-30, the wire attaches below the casting onto the electrode lead. Reinstall the black cover and insert the module back into the control panel (see Fig. 8). Be certain to put the red protective moisture cap on the button and secure the black plastic ring.

DO NOT OVER-TIGHTEN PLASTIC RING.

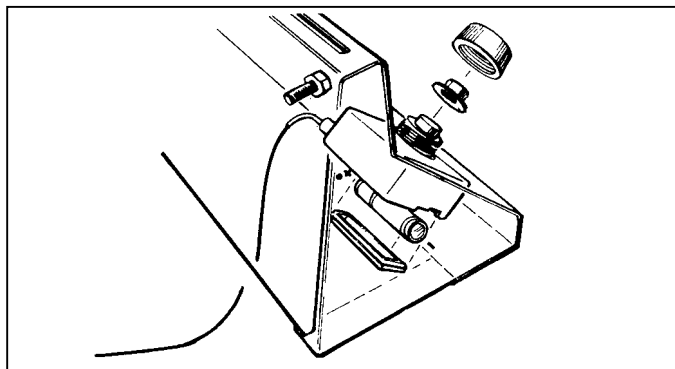

Figure 8 Ignition Module Assembly

NOTE: Replace battery when sparking sound either stops or noticeably slows down or every six months, whichever occurs first. If you are not going to use your grill for more than 30 days, remove the battery. Reinstall when you are ready to use your grill again.

SIDE SHELF ASSEMBLY

10. Install the left and right shelf brackets to the lower casting of your barbecue, using the four 1/4 X 20 X 3/4" hex bolts, secure with four 1/4" lock washes and four 1/4" hex nuts to hold each bracket (see Fig. 9). Attach shelf to the brackets by inserting the threaded screws on the shelf through the lower slots on the brackets. Let the shelf hang down. Attach the 10-32 Hex Nuts (see Fig. 10).



Figure 9 Installing Shelf Bracket

On portable models, this shelf, in the upright position, is to be used as a handle to move the barbecue around. It is a sturdy handle properly hinged securely into place (see Fig. 10).

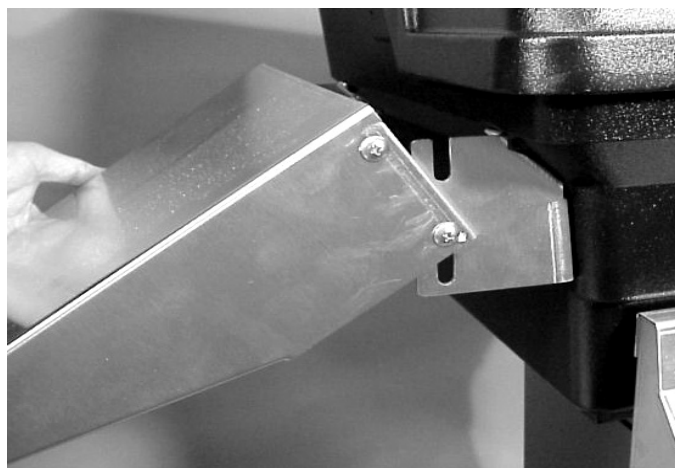

Figure 10 Hinging Shelf

11. Attach two control valve knobs to end of valve stems located in center of control panel. White mark should be pointing up to the OFF position.

FINISH ASSEMBLY

1. Be sure to remove plastic protective film. Place "Flare Guard" rock grate so that feet (bent ends) face down.
2. Place ceramic "Moon Rok II" on rock grate by evenly placing side by side. **DO NOT COVER HOLES IN THE "FLARE GUARD" ROCK GRATES.** Do not put more than one layer of rock on the grates (see Fig. 11).



Figure 11 Proper placement of rock grates and "Moon Rok II"

3. Place cooking grids in casting, "VARI GRID" cooking grids can be placed with close tines together in the middle or separated to the outside of the casting whichever better suits your grilling needs (see Fig. 12).



Figure 12 Placement of Cooking Grids

4. Place the warming rack in slots on top of the lower casting.

5. Place lid on lower casting. Insert hinge pins through top lid casting, then through pre-drilled hole in lower casting and attach cotter pins through hole in hinge pins to secure top to bottom casting (see Fig. 13).



Figure 13 Hinge Pins/Cotter Pins

6. Attach twin lid side "Stay Cool" handles using 5/16" X 3/4" bolt and star washer, tighten securely.

7. Slide grease tray into slot at top rear of pedestal. Tray must be tilted up before inserting in.

8. If you purchased a LC base kit you will need to attach the tank strap to the back of the cart. Attach as follows: Screw one of the #8 X 1/2" S.S. screws into the left hand nut that is pre-attached at the midpoint of the back of the pedestal so that it remains 1/4" out. Push the other #8 X 1/2" S.S. screw through tank strap. Screw this assembly into the pre-attached nut at the right hand side of the midpoint of pedestal. Tighten so that tank strap can still be raised up.

BE SURE TO START THESE SCREWS SLOWLY AND CAREFULLY TO ENSURE YOU DO NOT CROSS THREAD THE NUT OR SCREW.

CONNECTING GAS SUPPLY

1. If you have a portable model, connect 3/8" X 3/8" flare elbow fitting from either the 16" or 20" LP hose or the 12 foot gas hose to flare fitting on the feedline at back of pedestal (see Figs.14,15, &16). This is a brass to brass connection. **DO NOT USE ANY PIPE SEALER. DO NOT CROSS THREAD. TIGHTEN SECURELY.**

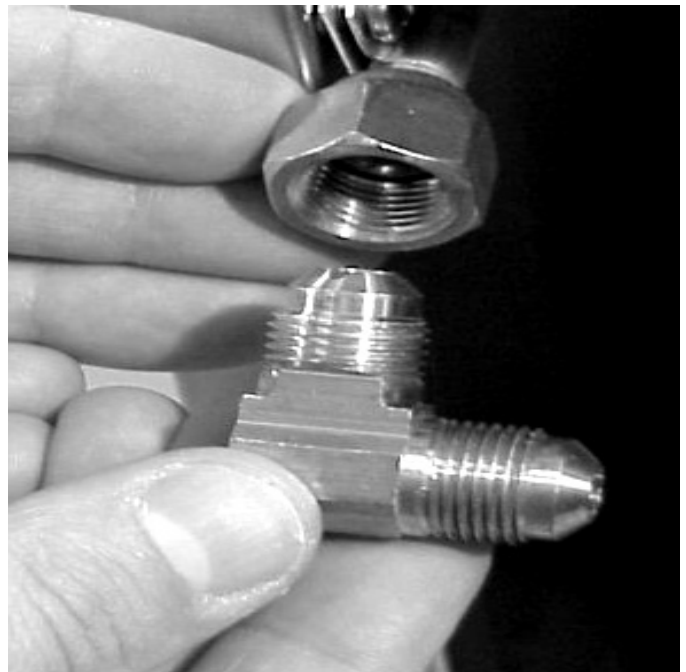

Figure 14 Brass Elbow

2. If you have natural gas, connect your gas supply to the feedline ending in a 3/8" female flare fitting at the back of the pedestal with an approved connector with shut off valve at a natural gas stub.



Figure 15 LP Hose/Regulator Connection

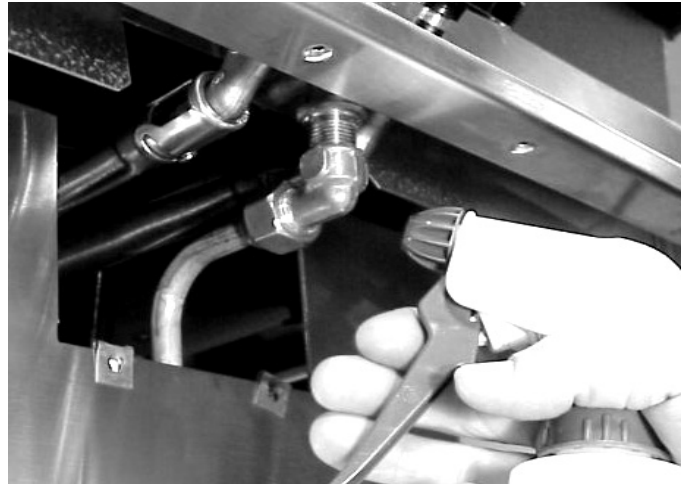

Figure 17 Leak Checking the Valve Connection



Figure 16 Natural Gas Hose Connection



2. TURN YOUR GAS SUPPLY (LP OR NAT) ON AND TEST ALL FITTINGS FOR LEAKS. BEFORE ATTEMPTING TO LIGHT GRILL, BE CERTAIN BOTH VALVES ARE IN THE OFF POSITION. TURN GAS SUPPLY ON (leaving both control knobs in the "OFF" position) AND CHECK ALL CONNECTIONS WITH A SOLUTION OF 50% LIQUID SOAP, 50% WATER. SOLUTION CAN BE SPRAYED ON WITH A SPRAY BOTTLE (see Fig. 17) OR PAINTED ON ALL CONNECTIONS WITH A BRUSH. IF BUBBLES APPEAR, TURN OFF GAS, TIGHTEN FITTINGS AND TRY AGAIN. NEVER CHECK FOR LEAKS WITH A MATCH OR FLAME.

4. If no gas leaks appear (bubbles), turn off gas supply and continue assembly. **IF YOU ARE UNABLE TO STOP A LEAK, CONTACT YOUR LOCAL DEALER FOR ASSISTANCE BEFORE PROCEEDING.**

5. If there are no gas leaks, attach the collar box with AGA/CGA rating sticker attaching to the pedestal as follows (see Fig. 18):

- Remove two #8 x 1/2" screws from bottom of control panel leaving attached Tinnerman clips.
- Attach two Tinnerman clips (found in pedestal parts bag) to lower two holes in the collar box.
- Place collar box inside opening in pedestal.
- Insert two #8 x 1/2" screws (found in pedestal parts bag) through pedestal into collar box and Tinnerman clips.
- Insert two #8 x 1/2" screws removed from control panel going first through top of collar box.

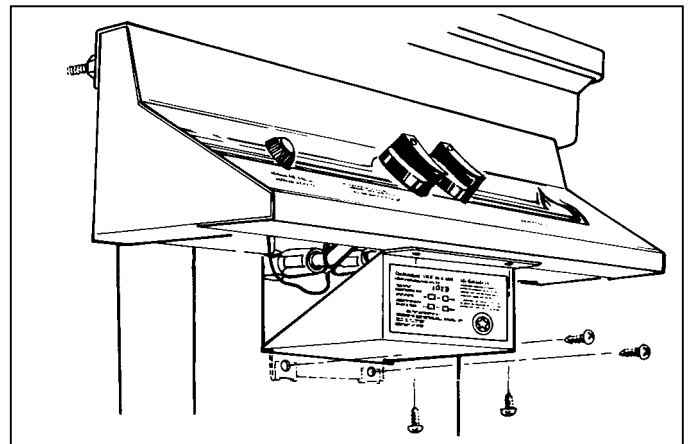

Figure 18 Collar box installation to pedestal and control panel

LIGHTING YOUR GRILL

BEFORE ATTEMPTING TO LIGHT YOUR GRILL, INSPECT THE HOSE OR GAS SUPPLY. If it is evident there is excessive abrasion or wear, or the hose is cut, it must be replaced prior to the grill being operated. Please contact your local dealer/distributor for an exact replacement hose.

ALWAYS OPEN THE LID COMPLETELY BEFORE LIGHTING THE BURNER. This is to avoid trapping gas fumes, which could ignite. Do not stand with your head over the grill when lighting the burner.

- ✓ Open the lid. Examine the interior to be sure it appears normal.
- ✓ Turn control knobs to OFF position. Either control knob may be used when lighting your PGS gas grill.
- ✓ Turn gas ON at tank or supply.
- ✓ Turn either knob to Medium and gently push the red button on control panel ignitor module. You should hear the ignitor clicking and one half of the burner should be lit within four seconds. Turn the other control knob on "HI" and the other burner will cross light automatically.
- ✓ Visually verify that the burner lights and the flame is acceptable. Close the grill top and let the ceramic rocks get hot. Pre-heat the grill on HI with the lid down for five to seven minutes. This will ensure even heat and allow cooking at MEDIUM, for the most part.

WE STRONGLY SUGGEST OBSERVING GRILL FOR TWO MINUTES BEFORE LEAVING. SMALL LEAKS AND OR SPIDER FIRES CAN EASILY BE REMEDIED IF CAUGHT IMMEDIATELY.

IF THE BURNER FAILS TO LIGHT

Immediately turn controls OFF to prevent gas build-up. Wait five minutes for gas to clear and try the above procedure again. If the burner does not light with the electronic ignition, light the burner with a match or other hand held ignitor. On the right hand side of the lower grill casting, near the bottom, there is a match lighting hole (see Fig. 19). Raise the grill lid. Light a long match (or other ignitor) and turn the RIGHT hand control knob to HI. Insert the lit match (or ignitor) into the hole to the end of the burner and light the grill. Under some adverse wind conditions it may be necessary to turn the grill or to light the burner via a vent opening under the grill head.

DO NOT TOSS A LIT MATCH INTO THE UNIT AND TURN THE GAS ON!



IF THE GRILL STILL FAILS TO LIGHT, CHECK THE GAS SUPPLY. YOU COULD BE OUT OF LP GAS OR THE MAIN GAS SUPPLY FOR NATURAL GAS MAY HAVE BEEN TURNED OFF. IF THE LP TANK HAS GAS OR THE NATURAL GAS IS TURNED ON AND THE GRILL STILL WILL NOT LIGHT: CHECK THE ELECTRONIC IGNITOR TO MAKE SURE IT IS SPARKING. IF NOT, CHECK THE BATTERY IN THE MODULE AND ALSO MAKE SURE THE IGNITOR WIRE IS CONNECTED BOTH TO THE MODULE AND TO THE BOTTOM OF THE ELECTRODE.

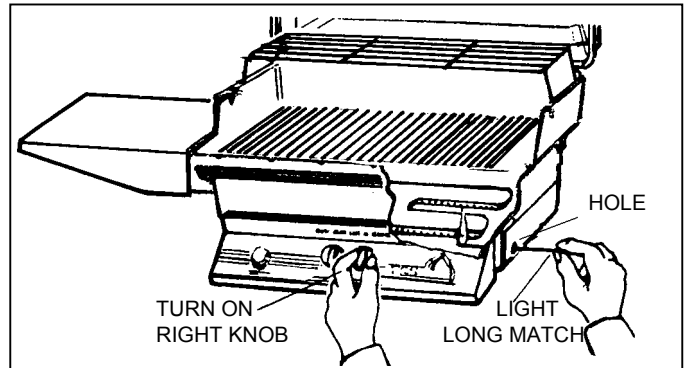

Figure 19 Manual Lighting of Grill

PERIODIC CLEANING

Knowing how to remove and replace the burner allows you to easily and thoroughly clean your grill. Even though "Burning Off" the grill after every cookout will keep it ready for instant use, once or twice a year you should perform basic maintenance to keep your grill in top operating condition.

BE SURE THAT YOUR BARBECUE IS COLD, GAS SUPPLY IS OFF AND THAT YOUR FEEDLINE IS BLED OF ANY GAS.

1. After removing cooking grids, ceramic rock and rock grates, remove your burner assembly by first carefully disconnecting the lead wire from your ignitor module. Gently pull the burner forward to release the spring clip, then pull the burner assembly forward and up. Cover the valve orifices with a small piece of aluminum foil to keep out dirt. Brush both sides and the bottom of the burner with a stiff wire brush. Any clogged flame holes may be opened using a thin wire. Use a venturi brush (or bottlebrush), pipe cleaner or long flexible wire to clean out the venturis. Since the grill housing is heavy rust-free cast aluminum, you are only trying to remove built up grease and debris.

2. DO NOT DAMAGE THE CERAMIC PROBE OR COLLECTOR BOX.

After cleaning burner assembly and the lower casting of grill, reinstall burner to lower casting.



TURN YOUR GAS SUPPLY (LP OR NAT) ON AND TEST ALL FITTINGS FOR LEAKS. BEFORE ATTEMPTING TO LIGHT GRILL, BE CERTAIN BOTH VALVES ARE IN THE OFF POSITION. TURN GAS SUPPLY ON (leaving both control knobs in the "OFF" position). CHECK ALL CONNECTIONS WITH A SOLUTION OF 50% LIQUID SOAP, 50% WATER. SOLUTION CAN BE SPRAYED ON WITH A SPRAY BOTTLE OR PAINTED ON ALL CONNECTIONS WITH A BRUSH. IF BUBBLES APPEAR, TURN OFF GAS, TIGHTEN FITTINGS AND TRY AGAIN. BE SURE ORIFICES ARE ENGAGED INTO THE BURNER VENTURIS.

3. The exterior of your grill has been powder coated and baked with a special high temperature powder process that seals the paint to the grill housing. The grill will retain its appearance with a little care. Occasional white oxidation may be washed off with a mild soap and warm water. Once oxidation is removed, turn your grill burners to low heat, close lid and allow to heat up for FIVE MINUTES. After grill housing is WARM apply a small amount of vegetable oil or PGS Stainless Steel Cleaner with a clean lint free cloth and apply evenly to grill housing. This method will keep your grill looking new for many years.

We also recommend keeping your grill covered at all times, when not in use.

For stubborn cases, high temperature touch up paint can make an old grill appear new. Allow 24 hours for paint to dry before using grill.

4. If your pedestal is black galvanized steel you can protect this with a car finish protectant. If you have a stainless support use a good grade of stainless cleaner such as our PGS "SSC" (Stainless Steel Cleaner).

5. To maintain cooking grids, we recommend brushing with a grill cleaning brass brush after grill has completely cooled. A light vegetable oil on grids just before cooking will prevent food from sticking to the surface. NEVER PLACE COOKING GRIDS IN A SELF-CLEANING OVEN. If grids are very dirty, you may want to see your PGS Dealer for a commercial quality grid cleaner. Be sure to oil before using.

In many areas, spiders or small insects have been found to create "flashback" problems. The spiders spin webs and/or insects build nests in the grill's venturi tube(s). The web and/or nests can lead to gas flow obstruction, which can damage your grill as it results in a "flashback" (a fire in the venturi tube(s)). The grill may still light, but the obstruction does not allow full gas flow to the burner. Therefore, some gas will back up and escape at the venturi air shutter. This will ignite, causing flashback, which could also damage your grill (see Fig. 20 a, b).

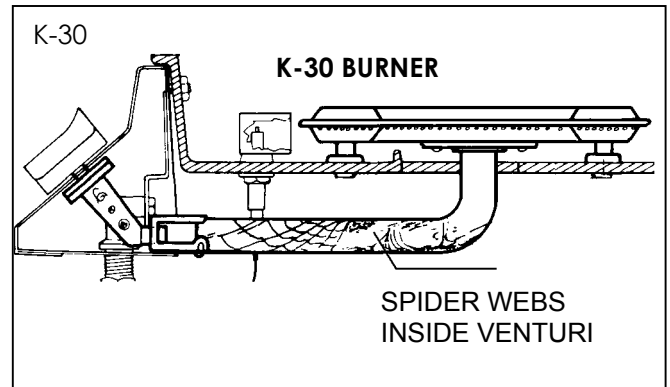

Figure 20 a Spider webs inside venturi

Your PGS grill has fine mesh brass screening placed around the burner venturis to minimize this problem. Please DO NOT damage or remove these screens when you clean your burners.

If you live in an area where spiders are plentiful, you should make it a point to clean the venturis often. You may want to spray around the bottom of your base with an insect repellent on a regular basis. You may also put MOTHBALLS in the bottom of your base.

PLEASE BE CERTAIN TO KEEP THEM AWAY FROM ANIMALS AND CHILDREN.

TO CLEAN BURNERS OF SPIDER WEBS SEE INSTRUCTION #1 OF PERIODIC CLEANING.

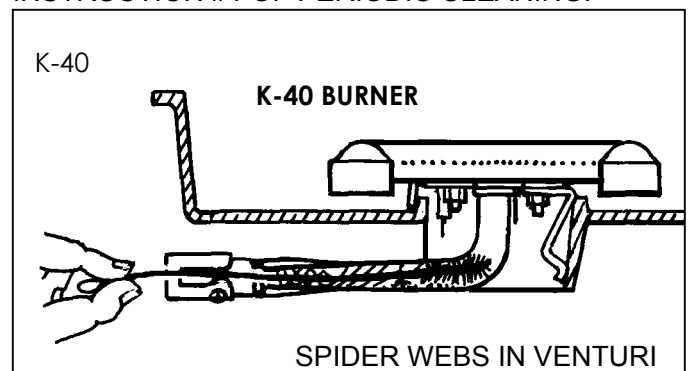

Figure 20 b Venturi cleaning out

FLASHBACK

BEFORE LIGHTING YOUR GRILL:

TURN YOUR GAS SUPPLY (LP OR NAT) ON AND TEST ALL FITTINGS FOR LEAKS. BEFORE ATTEMPTING TO LIGHT GRILL, BE CERTAIN BOTH VALVES ARE IN THE OFF POSITION. BE CERTAIN THAT YOUR GAS SUPPLY IS OFF AND YOUR GAS FEED LINE HAS BEEN BLED OF ANY FUEL. WHEN REINSTALLING BURNER, BE CERTAIN THAT THE BURNER VENTURIS ARE ENGAGED ON THE VALVES AT LEAST 1/4". TO TEST FOR GAS LEAKS TURN GAS SUPPLY ON (leaving both control knobs in the "OFF" position) AND CHECK ALL CONNECTIONS WITH A SOLUTION OF 50% LIQUID SOAP, 50% WATER. SOLUTION CAN BE SPRAYED ON WITH A SPRAY BOTTLE OR PAINTED ON ALL CONNECTIONS WITH A BRUSH. IF BUBBLES APPEAR, TURN OFF GAS, TIGHTEN FITTINGS AND TRY AGAIN.

ELECTRODE ADJUSTMENT

Model K-40 with the "Ultima" burner, the electrode is attached pre-set at the factory and should not require adjustment. In the model K-30 the electrode, inside the collector box, is also adjusted and checked at the factory for optimum spark. The tip is 1/8" from the inside surface of the collector box. In the event that the ceramic insulator should crack and need replacement, the collector box is easily removed by removing the large nut holding it to the bottom grill casting. The grill head must be removed from the pedestal support to replace the collector box (electrode and collector box are one unit).

Check the new part for proper spacing of the electrode end before installing. Since the feed-through fixture is threaded its full length, loosening and tightening two jam nuts will move the electrode tip closer or farther away from the collector box surface. For best spark, set at 1/8" (see Fig. 21 & 22).

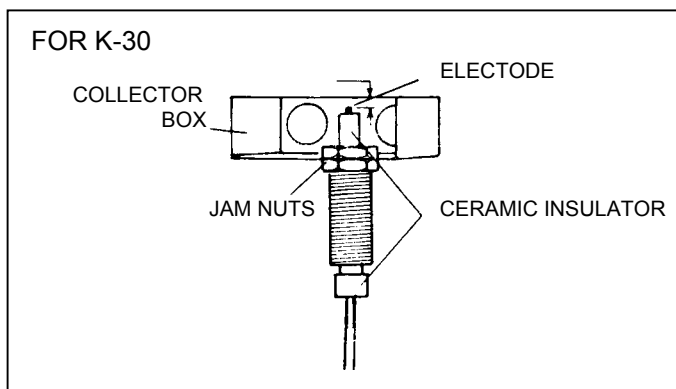

Figure 21 Proper electrode adjustment for K-30



Figure 22 Proper electrode adjustment for K-40

NOTE: Replace battery when sparks noticeably slows down or every six months (depending on usage). If you are not going to use your grill for 30 days or more, remove battery.

FLARE-UPS

When you cook fatty foods over an open flame, you can expect flare-ups. Natural juices falling on the hot ceramic rock results in flame and smoke that give foods cooked on your grill that delicious outdoor flavor and appearance. Expect and encourage a MODERATE amount of flare-up. We suggest that you trim off excess fat before cooking. Excessive flare-ups occur when cooking extra fatty foods, or if cooking temperatures are too high. To control flare-ups:

1. Turn your control knob to a lower heat setting.
2. Move the meat to another part of the grill, if possible. With a dual burner, you can cook on one side and move food, as necessary to the unlighted side or lower heat setting.
3. Cook with the lid open to reduce heat inside of grill head. Periodically flip rock so that it can self clean residual grease build-up.
4. If you need to immediately control any excessive flare-up, spray the flame with water or throw a small amount of baking soda directly on briquettes (avoid baking soda on food).

GREASE TRAY CLEAN OUT

We recommend periodic inspection and clean out of the grease tray provided with your PGS gas grill.

GAS GRILL CONVERSION

We strongly recommend having your gas grill converted by a servicing dealer, your local gas utility or other trained personnel.



**PLEASE NOTE: IMPROPER ORIFICE SIZE
COULD RESULT IN EITHER INSUFFICIENT
OR EXCESS GAS GOING TO BURNER,
AND MAY POSE A SAFETY RISK.**

HELPFUL TIPS

1. Before using your grill for the first time, please light and turn both burners on HI heat for ten to fifteen minutes. This will burn off any oils that are on new surfaces. Before grilling, we suggest putting a light coat of vegetable oil on your cooking grids. This should be done before you turn on your grill. A spray on oil, safflower or similar oil will work just fine.

2. Burning unit after each use is not required or recommended. Extended burning may cause premature wear on components or may damage your unit if left unattended. Pre-heating grill 5-7 minutes before each use will burn off most residue.

After the cooking grid has cooled, we recommend that you lightly rub the cooking grid with a nylon cleaning pad or similar material to remove any baked on foods. Please remember to lightly oil the cooking grid with a spray on oil, vegetable or safflower oil before using the next time.

If your grids have a lot of food on them, you may want to put them in a plastic bag with a cup of ammonia and leave them in the sun for a day... be sure to wash them thoroughly before using.

**YOU MAY CLEAN YOUR STAINLESS STEEL
COOKING GRIDS WITH A BRASS WIRE BRUSH.
DO NOT PLACE COOKING GRIDS, ROCK GRATES
OR ROCK IN A SELF-CLEANING OVEN.**

**ALWAYS KEEP YOUR GRILL COVERED WHEN
NOT IN USE.**

FLAME ADJUSTMENT TIPS

Your PGS burner has been designed to operate efficiently under widely varying operating conditions and is adjusted at the factory for proper operation so no adjustments should be required. Occasionally, vibration during transport or variations in local fuels and gas pressure, altitude, or other external conditions might require minor burner adjustments. Sometimes your burner will burn differently if your propane cylinder has been recently filled or it is near empty. Sometimes air will need to be purged from your natural gas line.

A qualified technician should make burner adjustments at the time of installation. Extreme care should be exercised if adjustments are required after installation. If you need to inspect and adjust burners while unit is operating:

Carefully remove rock grates, cooking grids, and rock from bottom casting. Burner adjustments can be best performed in low light and in **non-windy conditions** so you can properly view burner operation and make proper flame adjustments. Turn gas supply on and light grill as usual.

Inspect the burner when it is on low. Flames should be mostly blue and stable. The flame tips will be yellow at the ends and this is normal. When you re-install the rock grates the burner flames impinging on the rock grates will also cause the flame pattern to appear more yellow, this is normal and does not in any way affect the performance of your grill. A burner in an outdoor appliance operates in a different environment than an indoor appliance burner or flame and as a result will visually look different.

If you see the flames lifting from the burner, or only parts of the burner are burning, or if you hear excessive noise from the burner, please check the following: valve/orifice engagement in the venturis, that the burner is level in the casting, and also check burner tubes to be certain they are not obstructed with debris or spider webs. These conditions will more often be the case than the burner being out of adjustment. If you feel that you do need to adjust the burners please follow directions below when burners are cool to the touch:

1. Disconnect ignition wire at module. Disengage your burner by unclipping it from the rear and lifting forward and up.

2. At the end of each of the burner venturis you will see an air mixer secured by a small setscrew. When the screw is loosen the air shutter can be rotated to allow more or less air.

3. If the flame is extremely yellow this indicates the burner is getting insufficient air. Turn the air mixer to

the open position to allow more air to the burner. Tighten screw to insure mixer stays in this position.

4. If the flame is noisy and tends to lift away from the burner tube there is too much air being fed to the burner. Turn the air mixer to reduce the opening and air volume to the burner. Tighten screw to insure air mixture does not move.

5. Reinstall burner and light as normal and inspect flame. If burner requires additional adjustment repeat above procedure. There is not a significant degree of adjustment required to these burners. Differences in altitude, operating conditions, weather conditions, gas pressures, odorants and stabilizers used in both natural gas and propane will often cause burners to burn differently. As long as you are getting good ignition, even cooking performance, and the burner flame is blue with yellow tips and operating consistently, you should not have to adjust the burners. If you have any additional questions in this area, you should contact your local natural gas or propane utility or contact your authorized PGS dealer or distributor.

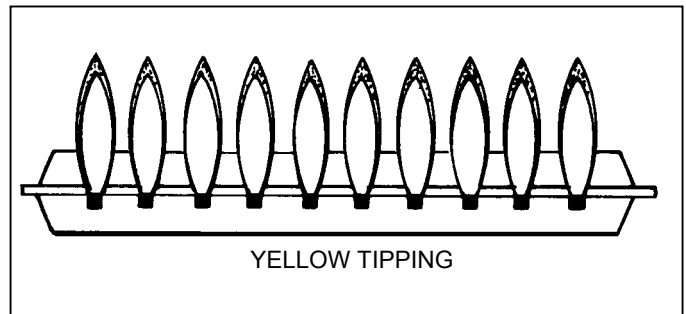

Properly adjusted burner

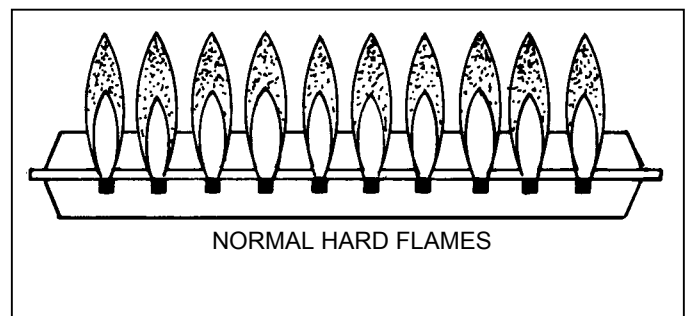

Slightly out of adjustment burner

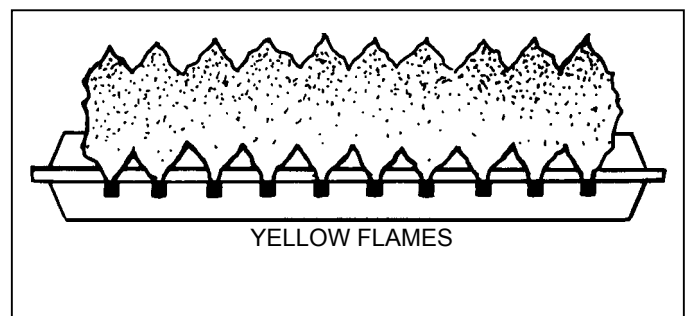

Extremely out of adjustment burner

PGS ACCESSORIES

To more fully enjoy your gas grilling experience, PGS has designed and manufactures a variety of accessories and barbecue Covers (not pictured). Please find a brief description of PGS accessories below:

INFRA-BROIL KIT

The PGS Infra-Broil Kit comes as a standard feature on our models K60, K40 ULTRA and K40 Delux and may be purchased as an accessory for any Model K30 or K40. The Infra-Broil is a rear burner especially designed for those back yard chefs who love to rotisserie. It features an all stainless steel enclosure for long lasting quality, 12,000 BTU of radiant heat for extremely efficient rotissing, rotisserie motor, thermometer and all hardware necessary to attach to your PGS grill; even a roasting pan to catch the juices! It will cook poultry and beef quickly and efficiently to perfection every time!



Infra-Broil Kit

SIDE BURNER KIT

The PGS Side Burner Kit comes standard on our Model K40 ULTRA. This is a commercial grade sealed gas top burner that will allow you to heat, sauté, boil, fry or even wok right outside next to your grilling. This accessory features an all stainless steel enclosure, electronic ignition, commercial grade burner and trivet, and all the hardware necessary to hook up to your existing PGS gas grill. We offer models for freestanding PGS grills as well as masonry-enclosed units.

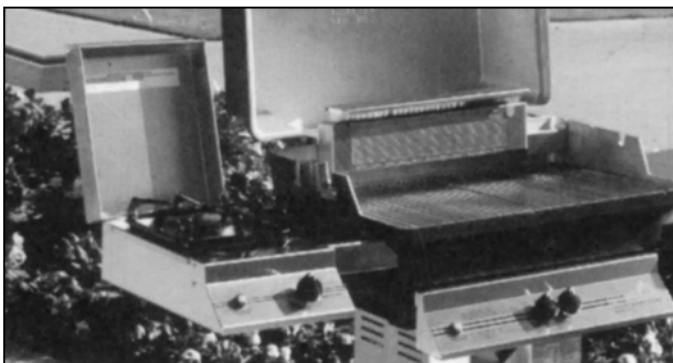

Side Burner Kit

GRILL CADDE

PGS offers a front mounting accessory that holds everything from bottle of BBQ sauce to a can of soda. It easily mounts to the front of our K30 or K40 grills (excepting the permanent post models) without any hardware and is constructed from commercial grade stainless steel.

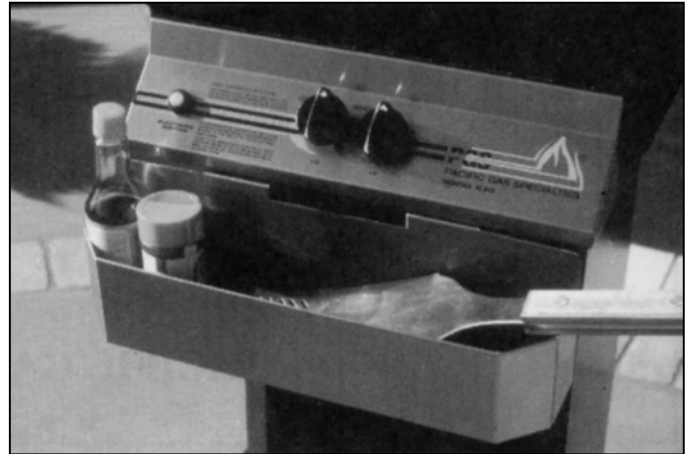

Cadde

SHISH KABOBS

We also have available the finest Shish Ka Bob skewers that feature long handles extending beyond the edge of the casting. They come packed in a set of six.

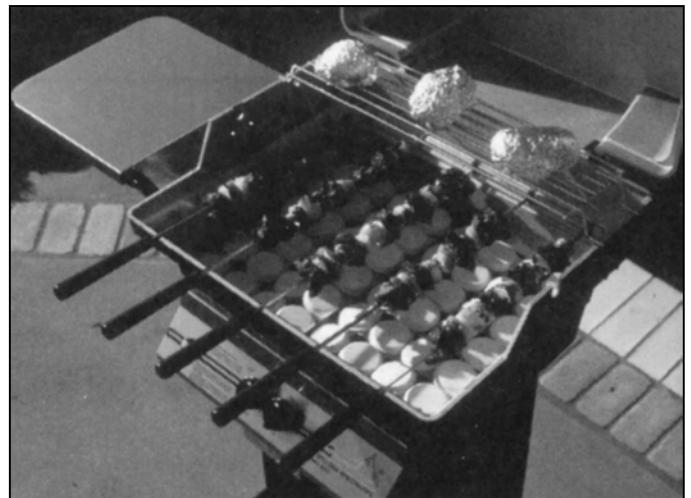

Shish Kabob Set

Your authorized PGS Dealer also offers a number of other accessories that includes the finest stainless steel cleaner (#SSC) to keep your grill looking brand new and a variety of covers specifically designed to fit your PGS grill and protect it from the elements. Please contact your local dealer for additional information.