



FRIEDRICH

1883

Room Air Conditioner
Service & Parts Manual
2014-2015

CP15 & CP18 & CP24

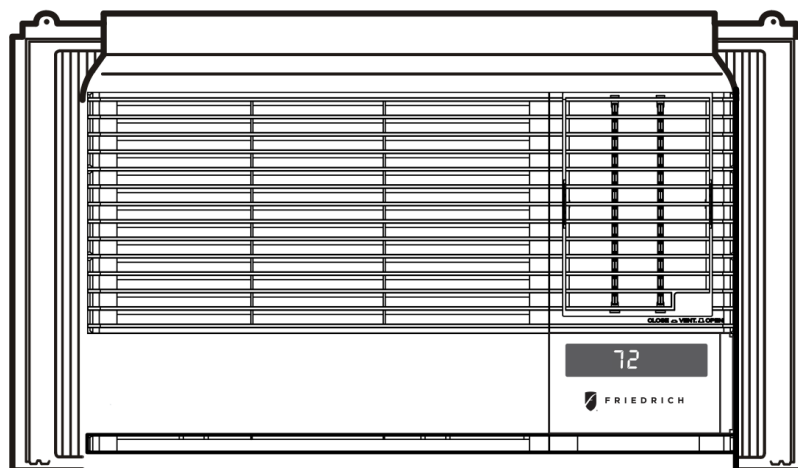

Chill

115 Volts-208/230V

CONTENTS

1. PREFACE

1.1 SAFETY PRECAUTIONS	2
1.2 INSULATION RESISTANCE TEST.....	2
1.3 PRODUCT SPECIFICATIONS	3
1.4 OPERATING INSTRUCTIONS.....	4

2. DISASSEMBLY INSTRUCTIONS

2.1 MECHANICAL PARTS.....	5
2.1.1 FRONT GRILLE	5
2.1.2 CABINET.....	5
2.1.3 CONTROL BOX	5
2.2 AIR HANDLING PARTS.....	6
2.2.1 COVER (AT THE TOP).....	6
2.2.2 AIR GUIDE AND BLOWER.....	6
2.2.2 FAN	7
2.2.3 SHROUD.....	7
2.3 ELECTRICAL PARTS	7
2.3.1 MOTOR.....	7
2.3.2 COMPRESSOR	7
2.3.3 CAPACITOR	8
2.3.4 POWER CORD	8
2.3.5 THERMISTOR	8
2.3.6 SYNCHRONOUS MOTOR.....	9

2.4 REFRIGERATION CYCLE.....	10
2.4.1 CONDENSER	10
2.4.2 EVAPORATOR	10
2.4.3 CAPILLARY TUBE.....	10

3. SCHEMATIC DIAGRAM

3.1 CIRCUIT DIAGRAM	13
---------------------------	----

4. TROUBLESHOOTING GUIDE

4.1 PIPING SYSTEM	14
4.2 TROUBLESHOOTING GUIDE.....	15

5. EXPLODED VIEW

6. SERVICE PARTS LIST

1. PREFACE

This SERVICE MANUAL provides various service information, including the mechanical and electrical parts etc. This room air conditioner was manufactured and assembled under a strict quality control system. The refrigerant is charged at the factory. Be sure to read the safety precautions prior to servicing the unit.

1.1 SAFETY PRECAUTIONS

1. When servicing the unit, turn off the air conditioner and unplug the power cord.
2. Observe the original lead dress.
If a short circuit is found, replace all parts which have been overheated or damaged by the short circuit.
3. After servicing the unit, make an insulation resistance test to protect the customer from being exposed to shock hazards.

1.2 INSULATION RESISTANCE TEST

1. Unplug the power cord and connect a jumper between 2 pins (black and white).
2. The grounding conductor (green or green & yellow) is to be open.
3. Measure the resistance value with an ohm meter between the jumpered lead and each exposed metallic part on the equipment.
4. The value should be over 1M .

1.3 PRODUCT SPECIFICATIONS

Buyer Model	CP15G10A	CP18G30A	CP24G30A
PERFORMANCE			
BTU performance (Cooling)	15000	17,500/18,000	23000/23500
BTU performance (Heating)			
EER	11.2	11.2/11.2	9.8/9.8
COP			
Dehumid. (Pts/Hr)	4.0	4.5	6.8
Dry Air Flow (CFM)	400	520	590
dBA Level (Indoor / Outdoor)	57/63	57/63	60/66
Est. Cooling Area (SQ.FT)	800	1000	1440
Electrical Ratings			
Voltage / 60 Hz	115	208/230	208/230
Watts (Cooling)	1330	1,560/1,600	2,340/2,390
Watts (Heating)			
Rated Amps (Cooling)	12	7.8/7.3	11.8/10.9
Rated Amps (Heating)			
Features			
Thermostat Control	Thermistor	Thermistor	Thermistor
Air Diflection	4-Way	4-Way	4-Way
Remote controller	Yes	Yes	Yes
Auto swing	Yes	Yes	Yes
Auto Restart	Yes	Yes	Yes
Energy saver fuction	Yes	Yes	Yes
Timer	24Hr,On/Off	24Hr,On/Off	24Hr,On/Off
Sleep	-	-	-
Filter Alarm Function	Yes	Yes	Yes
Fan Speed: Cooling(Heating)	3	3	3
Fan Only	3	3	3
Compressor	ROTARY	ROTARY	ROTARY
In Door Fan Type	TURBO	TURBO	TURBO
Type Air Discharge	Side	Side	Side
Outdoor Vent / Exhaust	Yes	Yes	Yes
Rear grille	Yes	Yes	Yes
Chassis Type	Slide In-Out	Slide In-Out	Slide In-Out
Others			
Carton	Height(inch)	21 3/16	21 3/16
	Width	29 3/8	29 3/8
	Depth	29 9/32	33
Demension	Height(inch)	16 27/32	16 27/32
	Width	25 1/2	25 1/2
	Depth	26 9/16	30 5/16
Net Weight(lbs.)	114	125	131
Shipplng Weight(lbs.)	125	138	144
Stuffing Quantity (20/4040Hi ft)	84/192/192	84/176/176	84/176/176

1.4 OPERATING INSTRUCTIONS

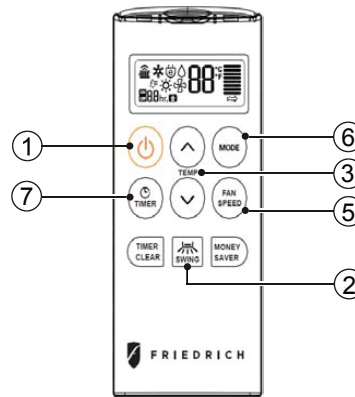
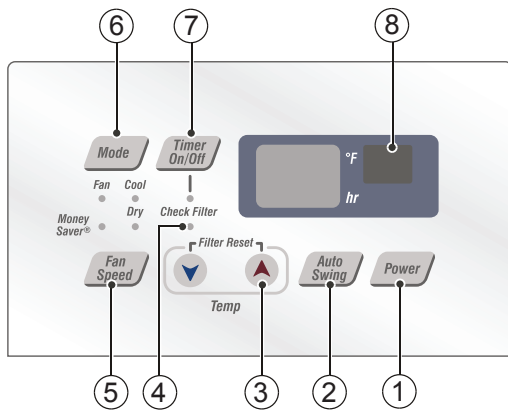

Control and Remote Control Operations

1. POWER

Operation begins when this button is pressed and stops when you press the button again.

2. AUTO SWING

This button can automatically control the air flow direction.

3. TEMPERATURE CONTROL

The thermostat monitors room temperature to maintain the desired temperature. The thermostat can be set between 60°F~86°F (16°C~30°C).

4. CHECK FILTER & FILTER RESET

Check Filter: Your 'Check Filter' LED will light up after approximately 250 hours of operation, notifying you that your filter needs to be cleaned.

Filter Reset: press 'Temp ∇ ∆' together to turn off 'Check Filter' light.

**Filter Reset must be done from unit control panel, not remote control*

5. FAN SPEED SELECTOR

For increased power while cooling, select a higher fan speed.

3 speeds: Low; Med; High

6. OPERATION MODE SELECTOR

Push the 'Mode' button to rotate between MoneySaver → Fan → Dry → Cool modes. (select Dry mode for dry/dehumidifier operation)

MoneySaver: The fan will stop when the compressor stops cooling. The fan will turn on approximately every 3 minutes to sample to room air and determine if more cooling is needed.

Fan Only: Fan-only operation

Cool: fan runs continually for normal cooling operation

**MoneySaver has it's own button on your remote control*

7. ON/OFF TIMER

ON: If the unit is off, use Timer to set number of hours before unit starts.

- Push Timer button to advance setting from 1hr
- 2hrs - ...24hrs maximum.

OFF: You will usually use shut-off time while you sleep.

- If unit is running, use Timer to set number of hours until shut-off.
- Push Timer button to advance setting from 1hr
- 2hrs....24hrs maximum.

**Timer Clear: On remote control, 'Timer Clear' button will cancel the timer setting*

8. REMOTE CONTROL SENSOR

To receive the signal from remote controller.

Inserting the Remote Control Batteries

1. Push out the cover on the back of the remote control with your thumb
2. Pay attention to polarity and insert two new AAA 1.5V batteries.
3. Reattach the cover.



NOTE: Do not use rechargeable batteries. Make sure that both batteries are new.

- In order to prevent discharge, remove the batteries from the remote control if the air conditioner is not going to be used for an extended period of time
- Keep the remote control away from extremely hot or humid places.

To maintain optimal operation of the remote control, the remote sensor should not be exposed to direct sunlight.

2. DISASSEMBLY INSTRUCTIONS

— Before the following disassembly, POWER SWITCH is set to OFF and disconnected the power cord.

2.1 MECHANICAL PARTS

2.1.1 FRONT GRILLE

1. Open the inlet grille upward or downward.
2. Remove the screw which fastens the front grille.
3. Pull the front grille from the right side.
4. Remove the front grille. (See Fig. 16)
5. Re-install the component by referring to the removal procedure.

NOTICE Mark ☒ of inlet grille means opening direction.

2.1.2 CABINET

1. After disassembling the front grille, remove the screws which fasten the cabinet at both sides. Keep these for later use.
2. Remove the two screws which fasten the cabinet at back. (See Fig. 17)
3. Pull the base pan forward.

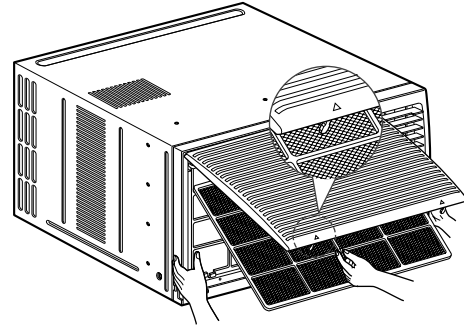

Figure 16

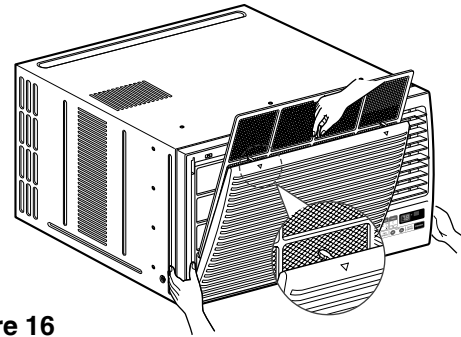

Figure 17

2.1.3 CONTROL BOX

1. Remove the front grille. (Refer to section 1)
2. Pull the base pan forward so that you can remove the 2 screws which fasten the cover control at the right side. (See Fig. 18)
3. Remove the 3 screws which fasten the controlbox. (See Fig. 18)
4. Discharge the capacitor by placing a 20,000 ohm resistor across the capacitor terminals.
5. Disconnect two wire housings in the control box.
6. Pull the control box forward completely.
7. Re-install the components by referring to the removal procedure. (See Fig. 18)

(Refer to the wiring diagram found on page 29~30 in this manual and on the control box.)

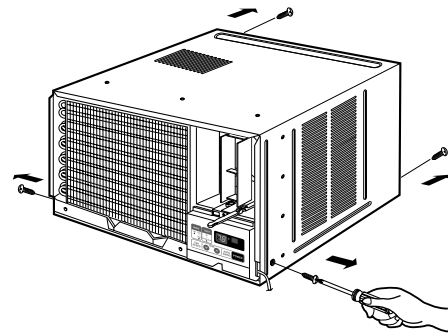
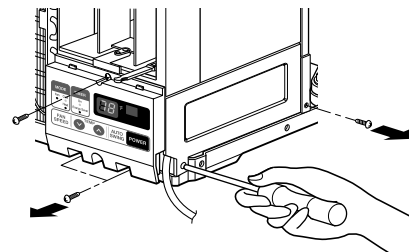

Figure 18



2.2 AIR HANDLING PARTS

2.2.1 Cover (at the top)

1. Remove the front grille. (Refer to section 1)
2. Remove the cabinet. (Refer to section 2)
3. Remove 11 screws which fasten the brace and covers.
4. Remove the covers and the brace. (See Fig. 19)
5. Re-install the components by referring to the removal procedure, above.

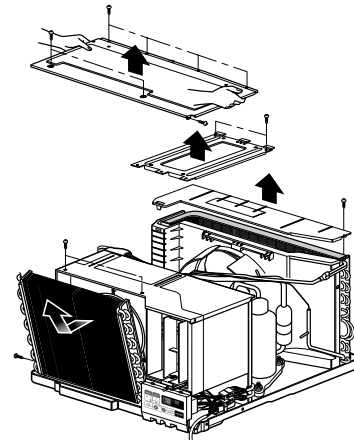

Figure 19

2.2.2 AIR GUIDE AND BLOWER

1. Remove the front grille.
2. Remove the cabinet.
3. Remove the control box.
4. Remove the 3 screws which fasten the brace.
5. Remove the brace.
6. Remove the 2 screws which fasten the evaporator.
7. Move the evaporator forward and pulling it upward slightly. (See Figure 20)
8. Move the evaporator to the left carefully.
9. Pull out the hook of orifice by pushing the tabs and remove it. (See Figure 21)
10. Remove the clamp with a hand plier which secures the blower.
11. Remove the blower.
12. Remove the 4 screws which fasten the air guide from the barrier.
13. Move the air guide backward, pulling out from the base pan.
14. Re-install the components by referring to the removal procedure, above.

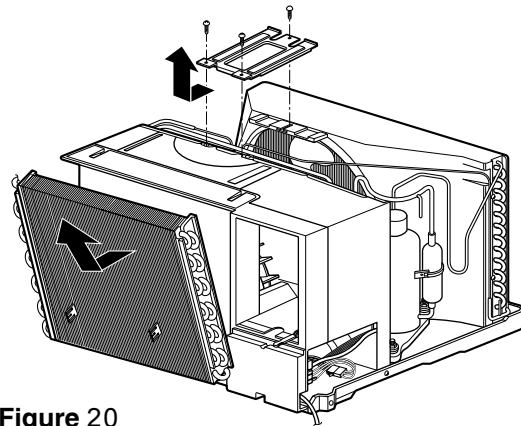

Figure 20

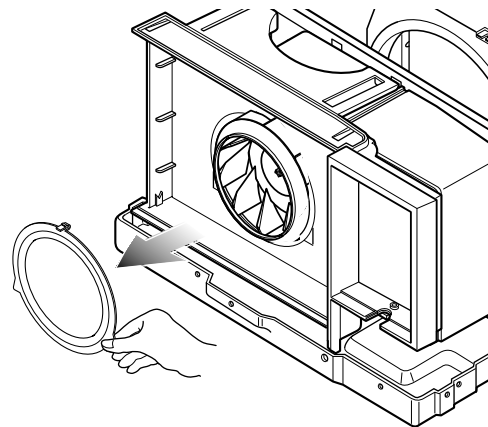

Figure 21

Figure 22

2.2.3 Fan

1. Remove the cabinet. (Refer to section 2)
2. Remove the brace and shroud cover. (Refer to section 4)
3. Remove the side cover with 2 screws. (See Fig. 23)
4. Remove the 5 or 6 screws which fasten the condenser.
5. Move the condenser sideways carefully.
6. Remove the clamp which secures the fan.
7. Remove the fan. (See Fig. 23)
8. Re-install the components by referring to the removal procedure, above.

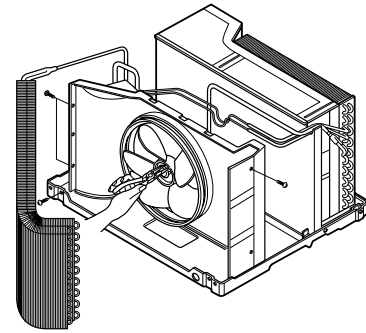

Figure 23

2.2.4 Shroud

1. Remove the fan. (Refer to section 6)
2. Remove the 2 screws which fasten the shroud.
3. Remove the shroud. (See Fig. 24)
4. Re-install the component by referring to the removal procedure, above.

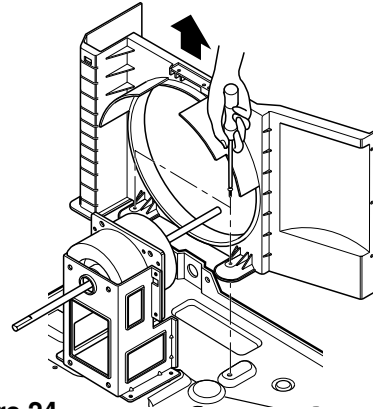

Figure 24

2.3 ELECTRICAL PARTS

2.3.1 Motor

1. Remove the cabinet. (Refer to section 2)
2. Remove the cover control and disconnect a wire housing in control box. (Refer to section 3)
3. Remove the blower. (Refer to section 5)
4. Remove the fan. (Refer to section 6)
5. Remove the 4 screws which fasten the motor. (See Fig. 25)
6. Remove the motor.
7. Re-install the components by referring to the removal procedure, above.

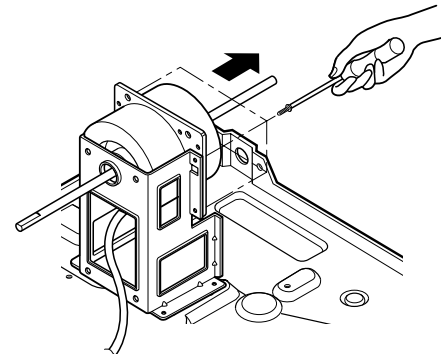

Figure 25

2.3.2 Compressor

1. Remove the cabinet. (Refer to section 2)
2. Discharge the refrigerant system using Freon™ Recovery System.
If there is no valve to attach the recovery system, install one (such as a watco a-1) before venting the Freon™. Leave the valve in place after servicing the system.
3. Disconnect the 3 leads from the compressor.
4. After purging the unit completely, unbraid the suction and discharge tubes at the compressor connections.
5. Remove the 3 nuts and the 3 washers which fasten the compressor. (See Fig. 26)
6. Remove the compressor.
7. Re-install the components by referring to the removal procedure, above.

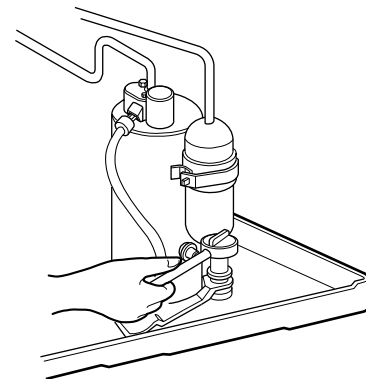

Figure 26

2.3.3 CAPACITOR

1. Remove the control box. (Refer to section 3)
2. Remove the screw and knobs which fasten the display panel.
3. Disconnect the 2 leads from the rocker switch and remove the panel.
4. Remove a screw and unfold the control box. (See Fig. 27)
5. Remove the screw and the clamp which fastens the capacitor. (See Fig. 27)
6. Disconnect all the leads of capacitor terminals.
7. Re-install the components by referring to the removal procedure, above.

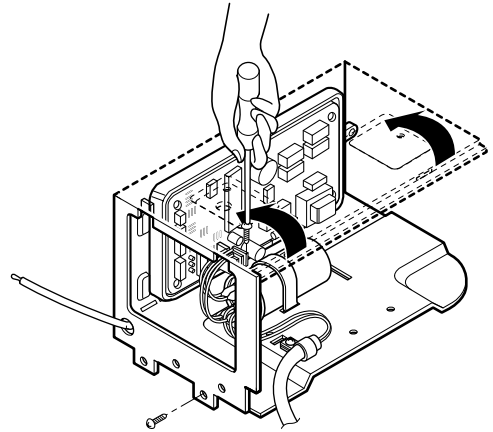

Figure 27

2.3.4 POWER CORD

1. Remove the control box. (Refer to section 3)
2. Unfold the control box. (Refer to section 10)
3. Disconnect the grounding screw from the control box.
4. Disconnect 2 receptacles.
5. Remove a screw which fastens the clip cord.
6. Pull the power cord. (See Fig. 28)
7. Re-install the component by referring to the removal procedure, above.
(Use only one ground-marked hole for ground connection.)
8. If the supply cord of this appliance is damaged, it must be replaced by the special cord.
(The special cord means the cord which has the same specification marked on the supply cord fitted to the unit.)

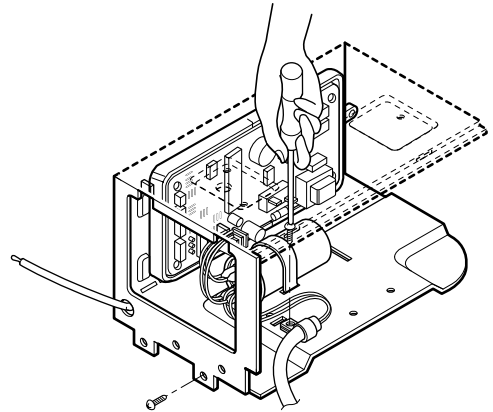

Figure 28

2.3.5 THERMISTOR

1. Remove the control box. (Refer to section 3)
2. Unfold the control box. (Refer to section 10)
3. Disconnect the thermistor terminals from main P.W.B assembly.
4. Remove the thermistor.
5. Re-install the components by referring to the removal procedure above. (See Figure 30)

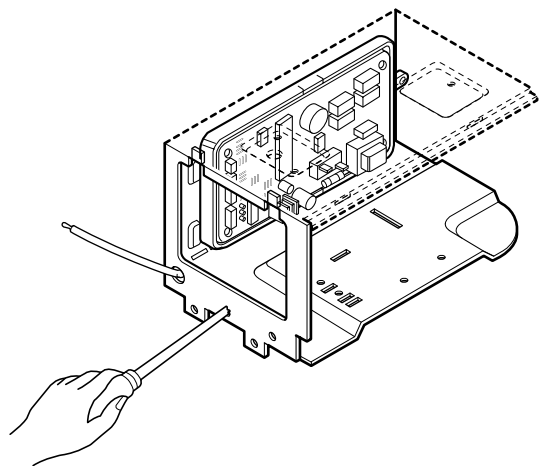

Figure 29

2.3.6 SYNCHRONOUS MOTOR

1. Remove the control box. (Refer to section 3)
2. Unfold the control box. (Refer to section 10)
3. Remove the crankshaft.
4. Disconnect all the leads of the synchronous motor.
5. Remove the 2 screws which fasten the synchronous motor. (See Fig. 30)
6. Re-install the components by referring to the removal procedure, above.

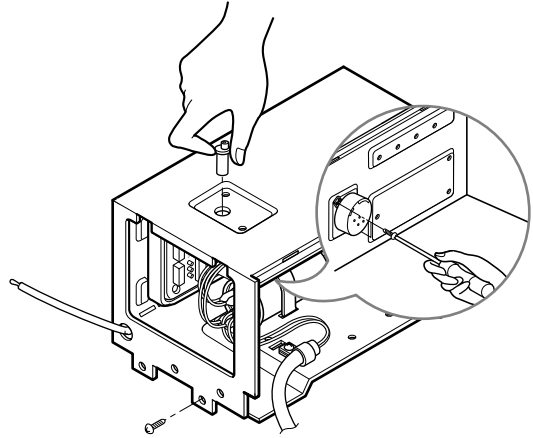

Figure 30

2.4 REFRIGERATION CYCLE



CAUTION: Discharge the refrigerant system using Freon™ Recovery System. If there is no valve to attach the recovery system, install one (such as a WATCO A-1) before venting the Freon™. Leave the valve in place after servicing the system.

2.4.1 CONDENSER

1. Remove the cabinet. (Refer to section 2)
2. Remove the brace and the shroud cover. (Refer to section 4)
3. Remove 2 screws which fasten the side cover. (See Fig. 31)
4. Remove the 5 or 6 screws which fasten the condenser.
5. After discharging the refrigerant completely, unbrazed the interconnecting tube at the condenser connections.
6. Remove the condenser.
7. Re-install the components by referring to notes. (See Fig. 31)

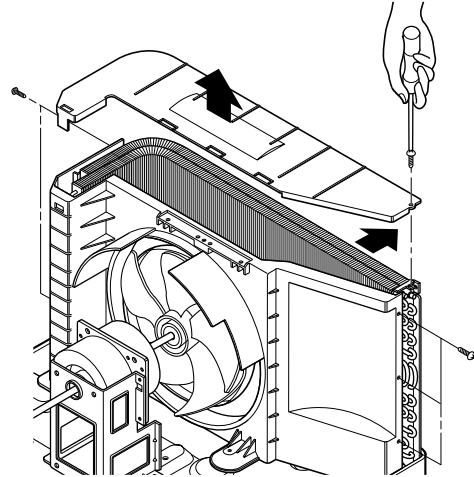

Figure 31

2.4.2 EVAPORATOR

1. Remove the cabinet. (Refer to section 2)
2. Remove the top cover and the brace. (Refer to section 4)
3. Discharge the refrigerant completely.
4. Remove the 3 screws which fasten the evaporator at the left side and the top side.
5. Move the evaporator sideward carefully and then unbrazed the interconnecting tube at the evaporator connectors.
6. Remove the evaporator.
7. Re-install the components by referring to notes. (See Fig. 32)

2.4.3 CAPILLARY TUBE

1. Remove the cabinet. (Refer to section 2)
2. Remove the brace. (Refer to section 4)
3. After discharging the refrigerant completely, unbrazed the interconnecting tube at the capillary tube.
4. Remove the capillary tube.
5. Re-install the components by referring to notes.

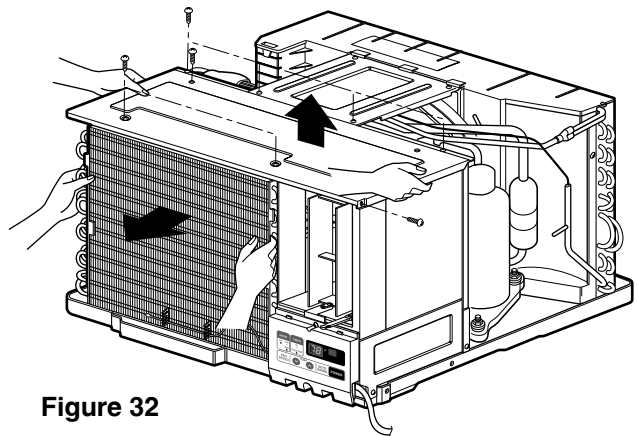

Figure 32

NOTICE

- Replacement of the refrigeration cycle.

1. When replacing the refrigeration cycle, be sure to discharge the refrigerant system using a Freon™ recovery System.
If there is no valve to attach the recovery system, install one (such as a WATCO A-1) before venting the Freon™. Leave the valve in place after servicing the system.
2. After discharging the unit completely, remove the desired component, and unbrace the pinch-off tubes.
3. Solder service valves into the pinch-off tube ports, leaving the valves open.
4. Solder the pinch-off tubes with Service valves.
5. Evacuate as follows.
 - 1) Connect the vacuum pump, as illustrated Fig. 35A.
 - 2) Start the vacuum pump, slowly open manifold valves A and B with two full turns counterclockwise and leave the valves closed.The vacuum pump is now pulling through valves A and B up to valve C by means of the manifold and entire system.



CAUTION: If high vacuum equipment is used, just crack valves A and B for a few minutes, then open slowly with the two full turns counterclockwise. This will keep oil from foaming and being drawn into the vacuum pump.

- 3) Operate the vacuum pump for 20 to 30 minutes, until 600 microns of vacuum is obtained. Close valves A and B, and observe vacuum gauge for a few minutes. A rise in pressure would indicate a possible leak or moisture remaining in the system. With valves A and B closed, stop the vacuum pump.
- 4) Remove the hose from the vacuum pump and place it on the charging cylinder. See Fig. 35B. Open valve C.
Discharge the line at the manifold connection.
- 5) The system is now ready for final charging.

6. Recharge as follows :

- 1) Refrigeration cycle systems are charged from the High-side. If the total charge cannot be put in the High-side, the balance will be put in the suction line through the access valve which you installed as the system was opened.
- 2) Connect the charging cylinder as shown in Fig. 35B.
With valve C open, discharge the hose at the manifold connection.
- 3) Open valve A and allow the proper charge to enter the system. Valve B is still closed.
- 4) If more charge is required, the high-side will not take it. Close valve A.
- 5) With the unit running, open valve B and add the balance of the charge.
 - a. Do not add the liquid refrigerant to the Low-side.
 - b. Watch the Low-side gauge; allow pressure to rise to 30 lbs.
 - c. Turn off valve B and allow pressure to drop.
 - d. Repeat steps B and C until the balance of the charge is in the system.
- 6) When satisfied the unit is operating correctly, use the pinch-off tool with the unit still running and clamp on to the pinch-off tube. Using a tube cutter, cut the pinch-off tube about 2 inches from the pinch-off tool. Use sil-fos solder and solder pinch-off tube closed. Turn off the unit, allow it to set for a while, and then test the leakage of the pinch-off connection.

Equipment needed: Vacuum pump, Charging cylinder, Manifold gauge, Brazing equipment. Pin-off tool capable of making a leak-proof seal, Leak detector, Tubing cutter, Hand Tools to remove components, Service valve.

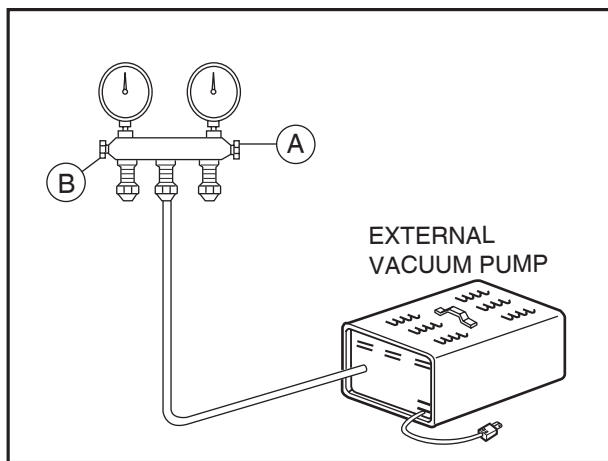
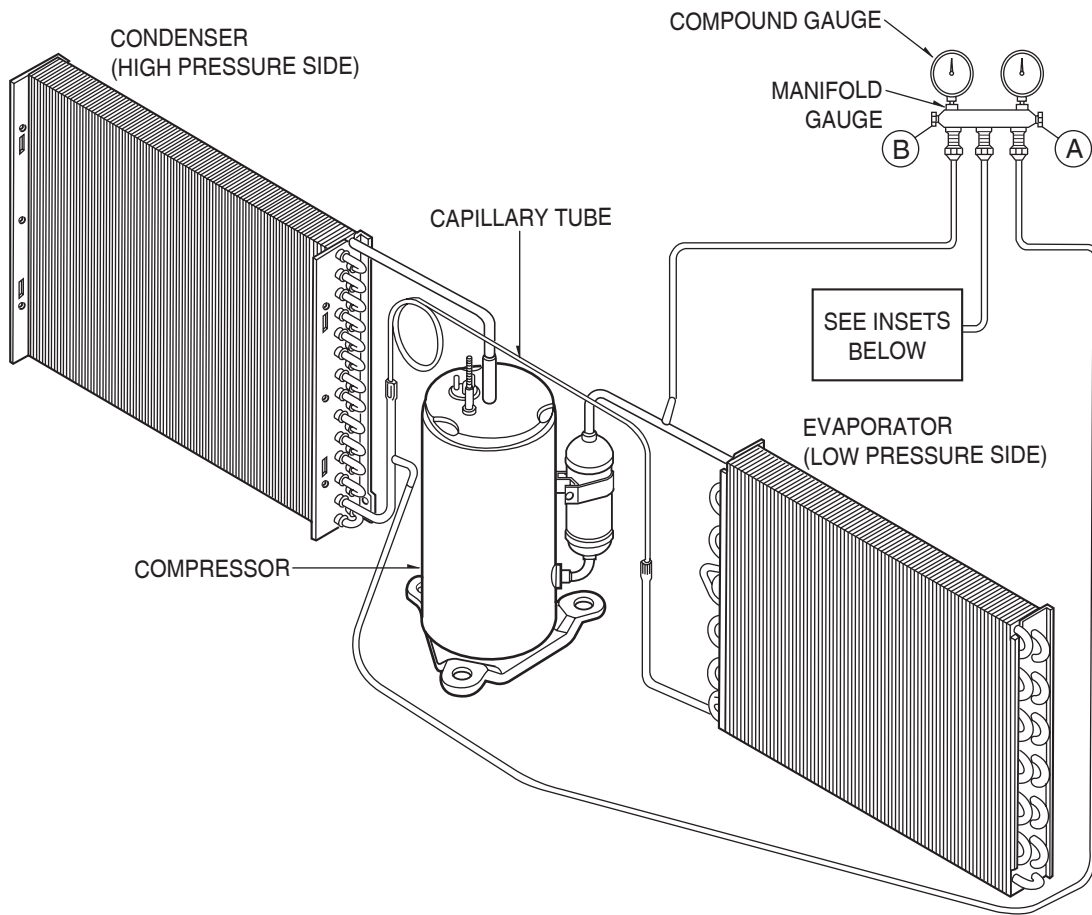

Figure 31A-Pulling Vacuum

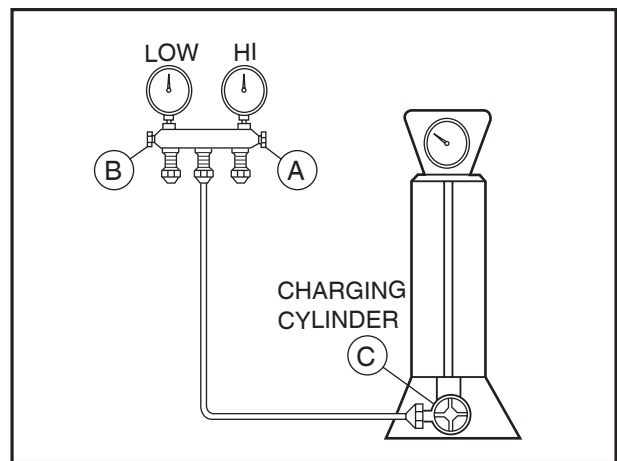
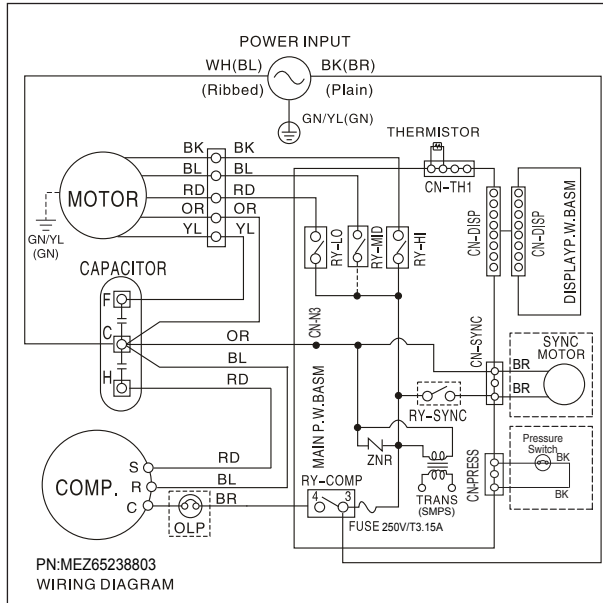

Figure 31B-Charging

3. SCHEMATIC DIAGRAM

3.1 CIRCUIT DIAGRAM



Fault Codes

Error No.	Error Item	Error Content
CH01	Indoor Air Sensor Error	Indoor air sensor open or short
CH09	EEPROM CheckSum Error	EEPROM reading date error
CH34	High Pressure Error	As high pressure, comp off over 10 times in 1 hour.

4. TROUBLESHOOTING GUIDE

4.1 PIPING SYSTEM

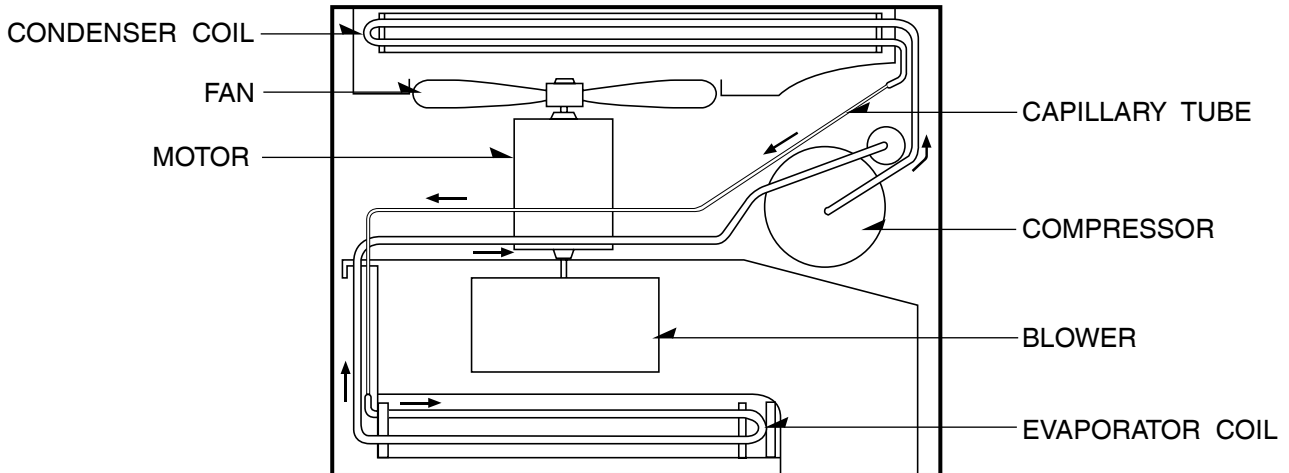
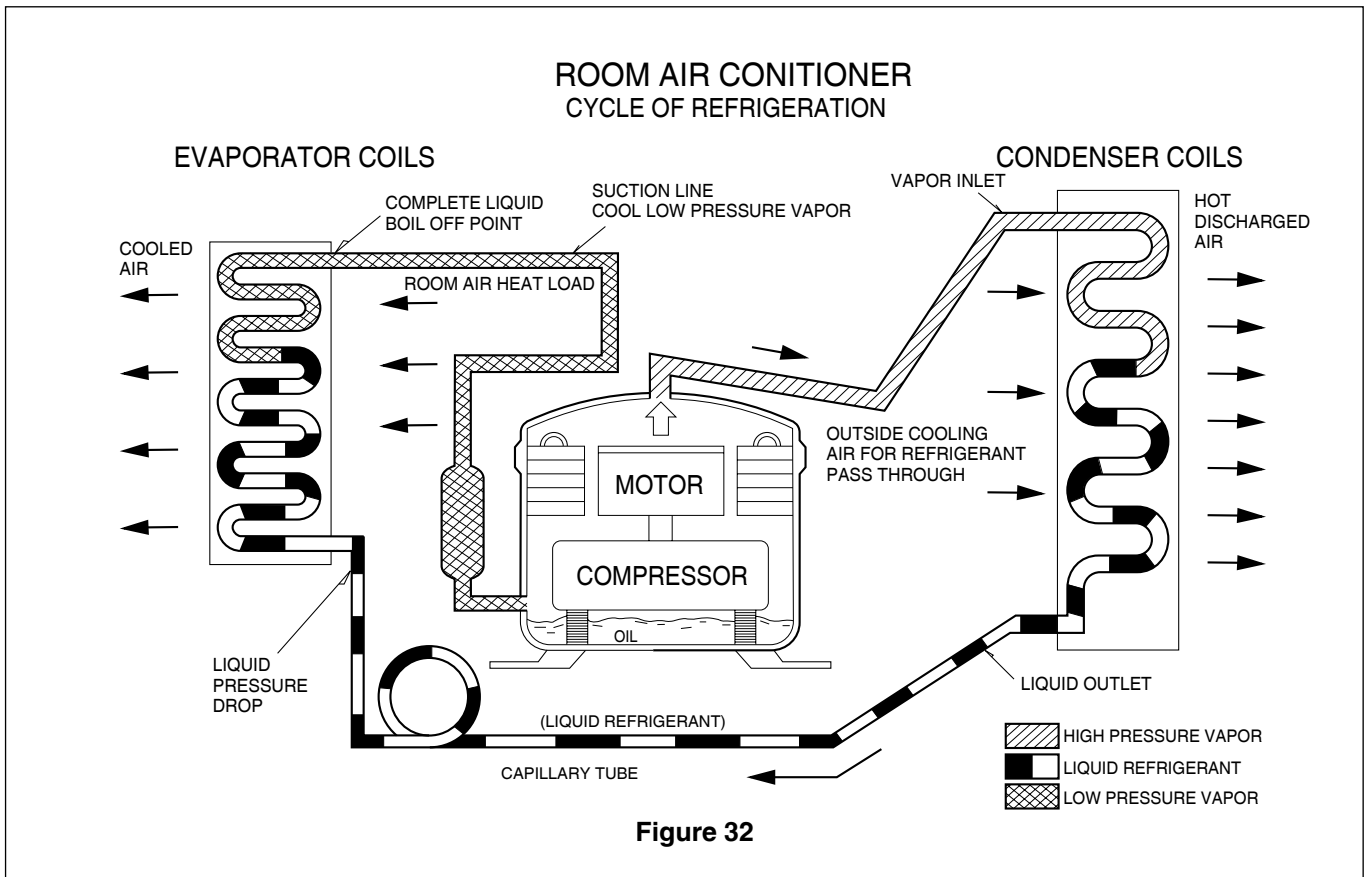

Figure 32 is a brief description of the important components and their function in what is called the refrigeration system. This will help you to understand the refrigeration cycle and the flow of the refrigerant in the cooling cycle.



4.2 TROUBLESHOOTING GUIDE

In general, possible trouble is classified in two causes.

The one is called Starting Failure which is caused from an electrical defect, and the other is Ineffective Air Conditioning caused by a defect in the refrigeration circuit and improper application.

Unit is running but cooling is ineffective

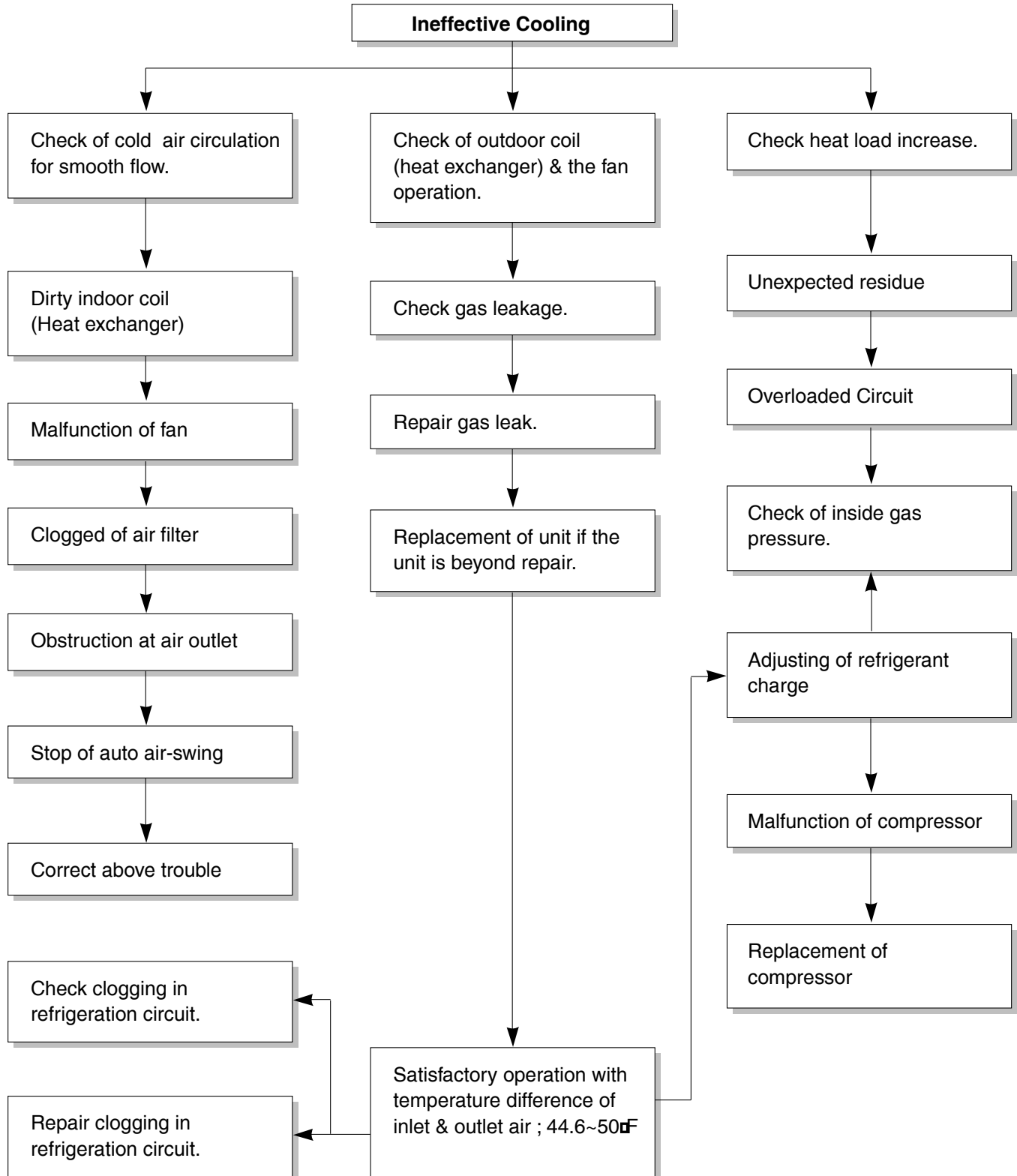

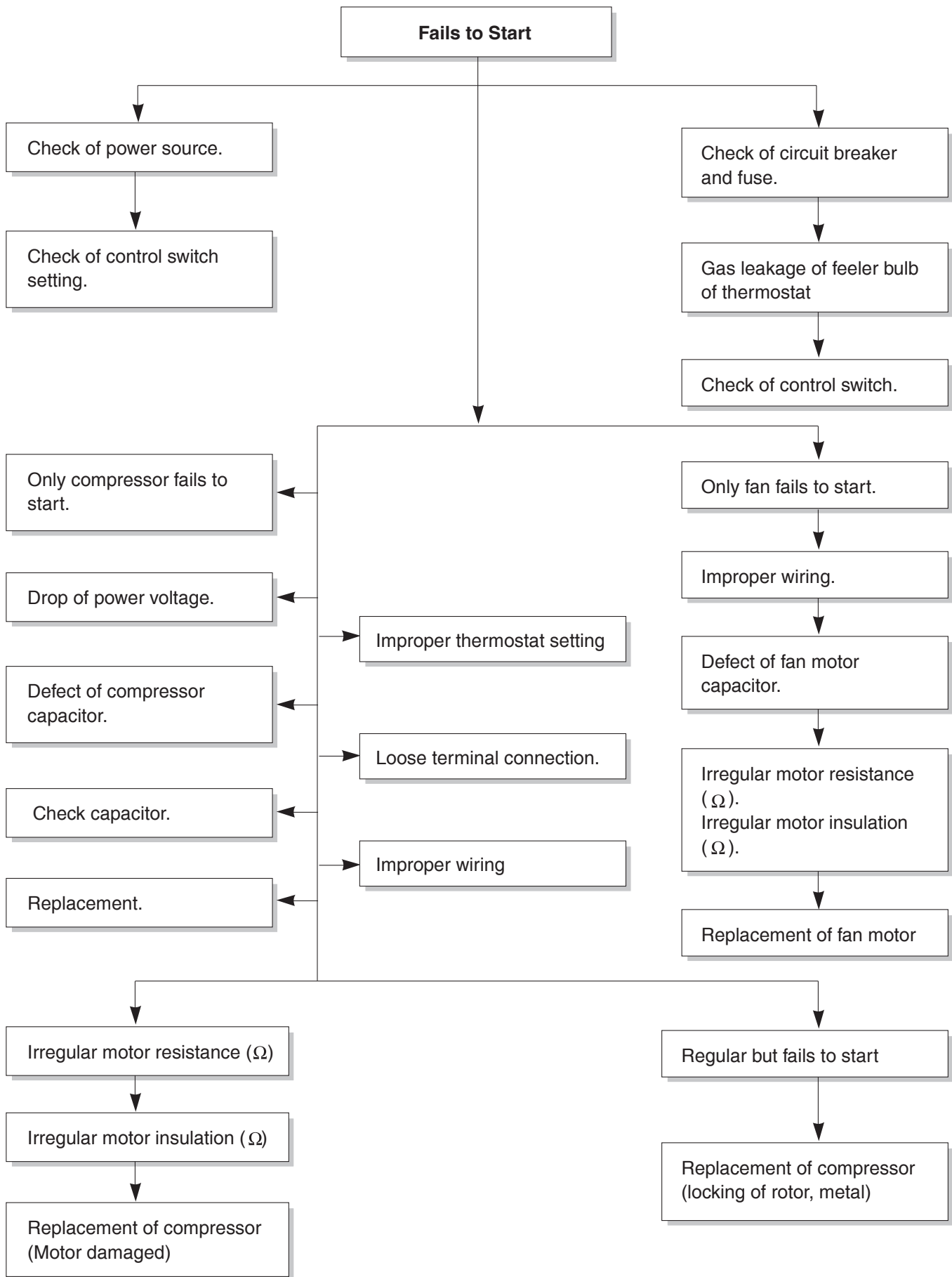

COMPLAINT	CAUSE	REMEDY
Fan motor will not run.	No power	Check voltage at outlet. Correct if none.
	Power supply cord	Check voltage to rotary switch. If none, check power supply cord. Replace cord if circuit is open.
	Rotary switch	Check switch continuity. Refer to wiring diagram for terminal identification. Replace switch if defective.
	Wire disconnected or connection loose	Connect wire. Refer to wiring diagram for terminal identification. Repair or replace loose terminal.
	Capacitor (Discharge capacitor before testing.)	Test capacitor. Replace if not within $\pm 10\%$ of manufacturer's rating. Replace if shorted, open, or damaged.
	Will not rotate	Fan blade hitting shroud or blower wheel hitting scroll. Realign assembly. Units using slinger ring condenser fans must have $\frac{1}{4}$ to $\frac{5}{16}$ inch clearance to the base. If it is hitting the base, shim up the bottom of the fan motor with mounting screw(s). Check fan motor bearings; if motor shaft will not rotate, replace the motor.
Fan motor runs intermittently	Revolves on overload.	Check voltage. See limits on this page. If not within limits, call an electrician. Test capacitor. Check bearings. Does the fan blade rotate freely? If not, replace fan motor. Pay attention to any change from high speed to low speed. If the speed does not change, replace the motor.
Fan motor noise.	Grommets	Check grommets; if worn or missing, replace them.
	Fan	If cracked, out of balance, or partially missing, replace it.
	Turbo fan	If cracked, out of balance, or partially missing, replace it.
	Loose set screw	Tighten it.
	Worn bearings	If knocking sounds continue when running or loose, replace the motor. If the motor hums or noise appears to be internal while running, replace motor.

COMPLAINT	CAUSE	REMEDY
Compressor will not run, but fan motor runs.	Voltage	Check voltage. See the limits on the preceding page. If not within limits, call an electrician.
	Wiring	Check the wire connections, if loose, repair or replace the terminal. If wires are off, refer to wiring diagram for identification, and replace. Check wire locations. If not per wiring diagram, correct.
	Rotary	Check for continuity, refer to the wiring diagram for terminal identification. Replace the switch if circuit is open.
	Thermostat	Check the position of knob. If not at the coldest setting, advance the knob to this setting and restart unit. Check continuity of the thermostat. Replace thermostat if circuit is open.
	Capacitor (Discharge capacitor before servicing.)	Check the capacitor. Replace if not within $\pm 10\%$ of manufacturer's rating. Replace if shorted, open, or damaged.
	Compressor	Check the compressor for open circuit or ground. If open or grounded, replace the compressor.
	Overload	Check the compressor overload, if externally mounted. Replace if open. (If the compressor temperature is high, remove the overload, cool it, and retest.)

ROOM AIR CONDITIONER VOLTAGE LIMITS

NAME PLATE RATING	MINIMUM	MAXIMUM
115V	103.5V	126.5V
208/230V	187V	253V

COMPLAINT	CAUSE	REMEDY
Compressor cycles on overload.	Voltage	Check the voltage. See the limits on the preceding page. If not within limits, call an electrician.
	Overload	Check overload, if externally mounted. Replace if open. (If the compressor temperature is high, remove the overload, cool, and retest.)
	Fan motor	If not running, determine the cause. Replace if required.
	Condenser air flow restriction	Remove the cabinet. inspect the interior surface of the condenser; if restricted, clean carefully with a vacuum cleaner (do not damage fins) or brush. Clean the interior base before reassembling.
	Condenser fins (damaged)	If condenser fins are closed over a large area on the coil surface, head pressures will increase, causing the compressor to cycle. Straighten the fins or replace the coil.
	Capacitor	Test capacitor.
	Wiring	Check the terminals. If loose, repair or replace.
	Refrigerating system	Check the system for a restriction.
Insufficient cooling or heating	Air filter	If restricted, clean or replace.
	Exhaust damper door	Close if open.
	Unit undersized	Determine if the unit is properly sized for the area to be cooled.
Excessive noise.	Blower or fan	Check the set screw or clamp. If loose or missing, correct. If the blower or fan is hitting air guide, rearrange the air handling parts.
	Copper tubing	Remove the cabinet and carefully rearrange tubing not to contact cabinet, compressor, shroud, and barrier.

5. EXPLODED VIEW

CP15G30A

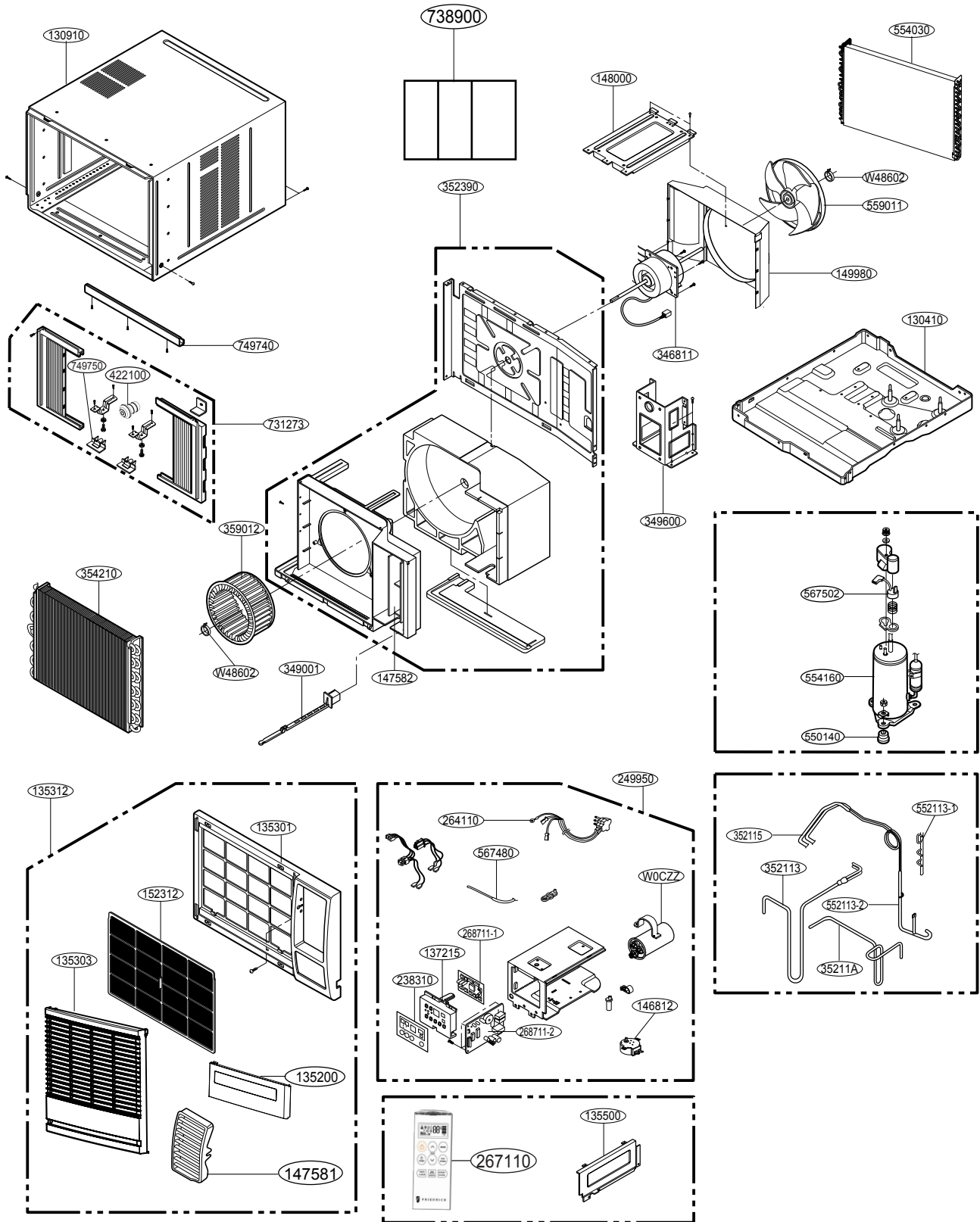

REF	DESCRIPTION	PART NO#	MODELS			NOTES
			CP15G33A	CP18G33A	CP24G33A	
130410	BASE PAN	67304014		1		
130410	BASE PAN	67305568	1			
352390	GUIDE ASSEMBLY AIR	67303510	1	1	1	
349001	DAMPER VENT	67303509	1	1	1	
349600	MOTOR BRACKET	67303609	1	1	1	
147582	LOOVER VERTICAL	67306266	1	1		
149980	SCHROUD	67303118	1	1	1	
346811	MOTOR, AC	37303041		1		
346811	MOTOR, AC	67303043	1			
346811	MOTOR, AC	67303042			1	
559011	FAN ASSEMBLY CONDENSOR	67302619	1	1	1	
359012	TURBO FAN EVAP.	67302618	1	1	1	
W48602	CLAMP SPRING	67302501	1	1	1	
148000	SUPPORTER	67303912		1	1	
148000	SUPPORTER	67303911	1			
554160	COMPRESSOR	67305020		1		
554160	COMPRESSOR	67305021			1	
554160	COMPRESSOR	67305019	1			
135500	COVER ASSY. TOP	67302750			1	
567502	OVERLOAD	67301915	1			
354210	EVAPORATOR	67302444	1	1		
354210	EVAPORATOR	67302445			1	
352113	TUBE ASSEMBLY, SUCTION	67302257		1		
352113	TUBE ASSEMBLY, SUCTION	67302258			1	
352113	TUBE ASSEMBLY, EVAPORATOR	67302443	1			
352213	TUBE ASSEMBLY EVAPORATOR	67302253		1		
352115	TUBE ASSEMBLY EVAPORATOR	67302447			1	
554030	CONDENSOR ASSEMBLY	67302438	1	1		
554030	CONDENSOR ASSEMBLY	67302439			1	
352111	TUBE ASSEMBLY, CONDENSOR	67302260			1	
352111	TUBE ASSEMBLY, CONDENSOR	67302141		1		
35211A	TUBE ASSEMBLY, DISCHARGE	67302256		1		
35211A	TUBE ASSEMBLY, DISCHARGE	67302259			1	
35211A	TUBE ASSEMBLY, DISCHARGE	67302254	1	1		
552113	TUBE ASSEMBLY CONNECTOR	67302253	1			
566000	PRESSUR SWITCH	67307669			1	
249950	CASE ASSEMBLY CONTROL	67305578			1	
249950	CASE ASSEMBLY CONTROL	67302751		1		
249950	CASE ASSEMBLY CONTROL	67305576	1			
352115	TUBE ASSEMBLY SUCTION	67302446		1		
552113-1	TUBE ASSEMBLY CONDENSOR	67302141	1			
552113-2	TUBE ASSEMBLY, CONNECTOR	67302253	1			

REF	DESCRIPTION	PART NO#	MODELS			CODE
			CP15G10A	CP18G33A	CP24G33A	
749740	GUIDE	67304014	1	1	1	
130910	CABINET ASSEMBLY	67303722		1	1	
130910	CABINET ASSEMBLY	67305541	1			
268711-2	PCB ASSEMBLY MAIN	67307675	1			
268711-2	PCB ASSEMBLY MAIN	67307676		1		
268711-2	PCB ASSEMBLY MAIN	67307677			1	
268711-1	PCB ASSEMBLY DISPLAY	67307674	1	1	1	
738900	REAR GRILL	67306115	1			
264110	POWER CORD	67300025	1			
264110	POWER CORD	67300032		1		
264110	POWER CORD	67300029			1	
W0CZZ	CAPICATOR	67301914	1			
W0CZZ	CAPICATOR	67300709		1		
W0CZZ	CAPICATOR	67300733			1	
567480	THERMISTOR	67307806	1	1	1	
146812	MOTOR, AC	67300903		1	1	
146812	MOTOR, AC	67300902	1			
135312	INDOOR GRILL ASSEMBLY	67302757	1			
135312	INDOOR GRILL ASSEMBLY	67302762				
267110	REMOTE	67302251		1	1	
267110	REMOTE	67302252	1			
135500	COVER ASSEMBLY CONTROL	67302751		1		
135301	GRILL, FRONT	67304806	1	1		
135301	GRILL, FRONT	67304806			1	
135303	GRILL, INLET	67304807	1	1	1	
731273	INSTALL PART ASSEMBLY, SINGLE	67306319	1	1	1	
749750	GUIDE	67306400	2	2	2	
422100	DRAIN PIPE NIPPLE	67307000	1	1	1	
147581	LOOVER HORIZONTAL	67305544		1	1	
147581	LOOVER HORIZONTAL	67305549	1			
135200	COVER ASSEMBLY	67305567	1	1	1	
152312	AIR FILTER	67304312	1	1	1	

5. EXPLODED VIEW

CP18G30A

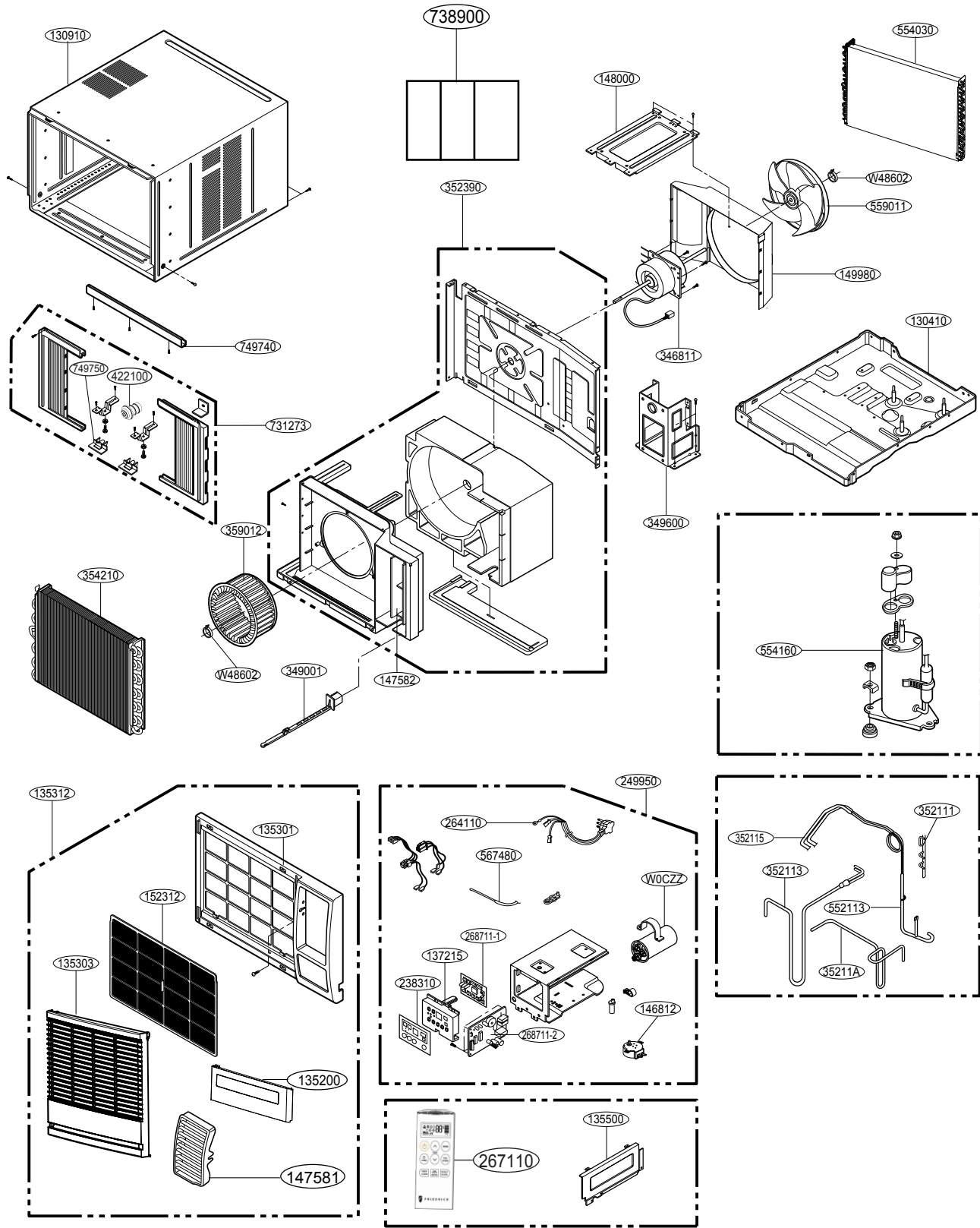

CP24G30A

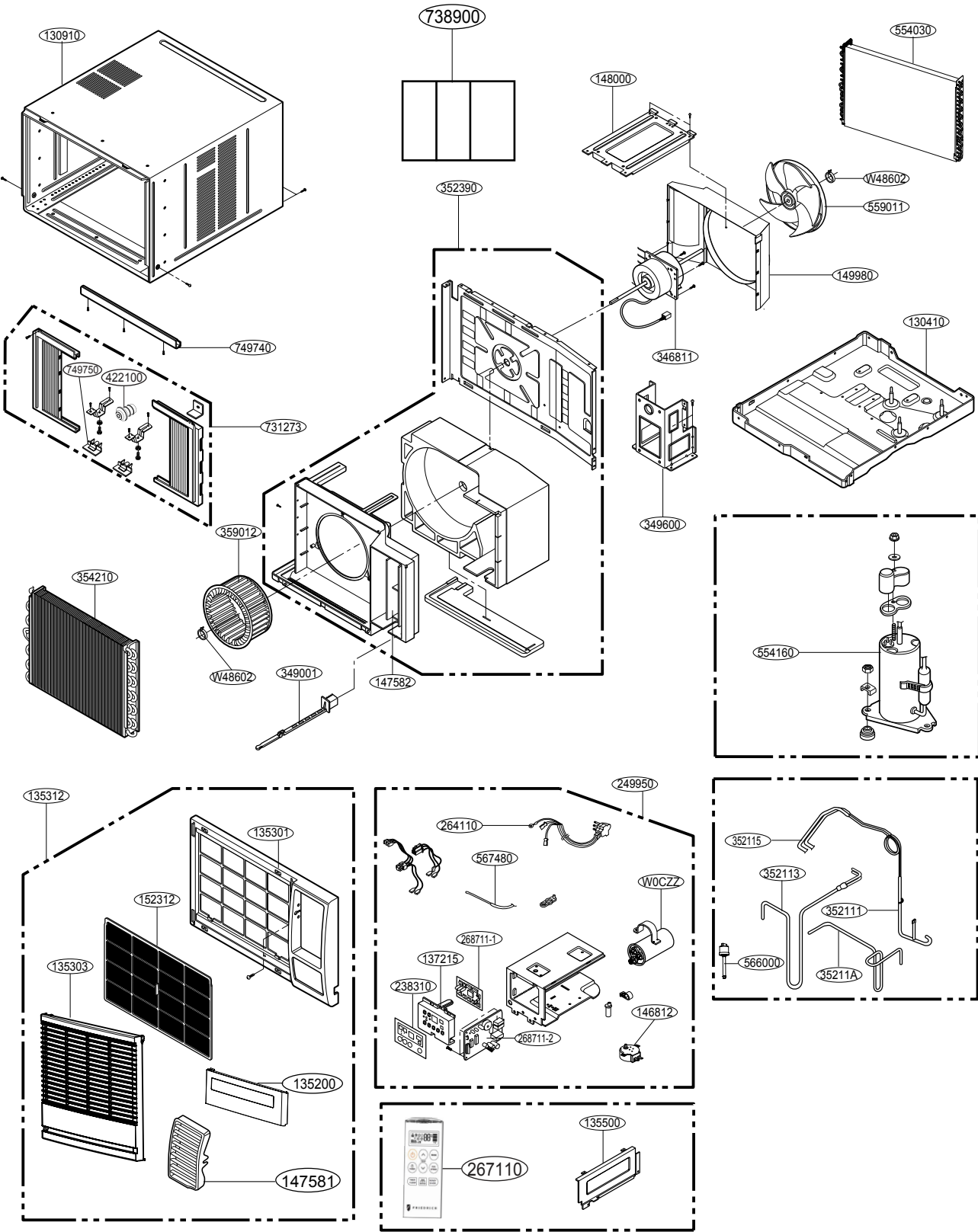



F R I E D R I C H

FRIEDRICH AIR CONDITIONING CO.

Visit our web site at www.friedrich.com

10001 Reunion Place, Suite 500 • San Antonio, TX 78216
(800)541-6645