

This Owner's Manual is provided and hosted by [Appliance Factory Parts](#).



# Grand Hall B2610ALP Owner's Manual

[Shop genuine replacement parts for Grand Hall  
B2610ALP](#)



[Find Your Grand Hall Grill Parts - Select From 203 Models](#)

----- Manual continues below -----

# grandhall

## Operator's Manual

Liquid Propane Gas (LPG) Grill

Models OB2610ALP, OB3210ALP & OB3210BLP

Natural Gas (NG) Grill

Models OB2610ANG, OB3210ANG & OB3210BNG

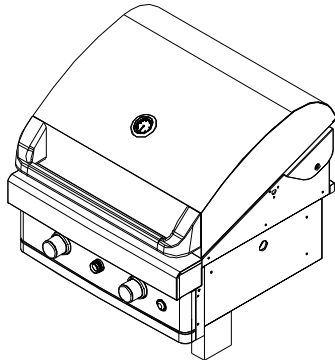

OB2610ALP/NG  
(For Built-in Model)

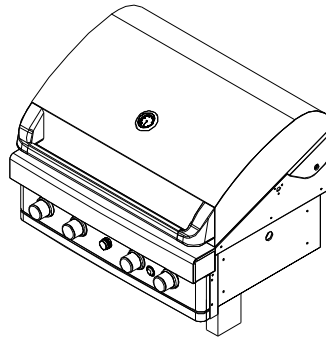

OB3210ALP/NG  
(For Built-in Model)

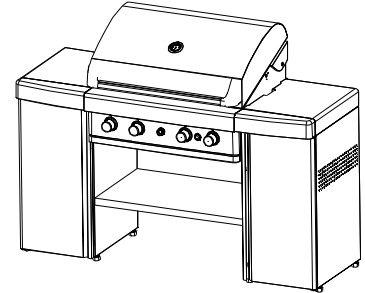

OB3210BLP/NG  
(For Cabinet Model)

### FREE HELP FROM THE GRILL EXPERTS

Grand Hall is the expert on this product and trained to help you with:

- Y Assembly Questions
- Y Grill Operation
- Y Replacement of Damaged or Missing parts

visit [www.grandhall.com](http://www.grandhall.com) or call:

1-877-934-7455

Monday - Friday 8:00am-4:30pm CST

### IMPORTANT:

#### Y NOTE TO ASSEMBLER/INSTALLER:

Leave this manual with the consumer.

#### Y NOTE TO CONSUMER:

Keep this manual for future reference.

#### Y RECORD YOUR SERIAL # \_\_\_\_\_

(see silver CSA label on main body of grill)



### WARNING



- Y Failure to comply with these instructions could result in a fire or explosion that could cause serious bodily injury, death or property damage.
- Y Whether this grill was assembled by you or someone else, you must read this entire manual before using your grill to ensure the grill is properly assembled, installed and maintained.
- Y **Use your grill at least 3 feet away from any wall or surface.** Use your grill at least **3 feet away** from combustible objects that can melt or catch fire such as vinyl or wood siding, fences and overhangs or sources of ignition including pilot lights on water heaters and live electrical appliances.
- Y THIS GAS APPLIANCE IS DESIGNED FOR OUTDOOR USE ONLY.
- Y **Never** use your gas grill in a garage, porch, shed, breezeway or any other enclosed area.
- Y **Never** obstruct the flow of ventilation air around your gas grill housing.
- Y **Never** disconnect the gas regulator or any gas fitting while your grill is lit. A lit grill can ignite leaking gas and cause a fire or explosion which could result in property damage, personal injury or death.

## Table of Contents

Primary Safety Warnings .....	1-3
Pre-Assembly Instructions.....	3
Part Diagrams and Lists .....	4-13
Assembly Instructions.....	14-25
LP Gas Tank Installation.....	26
Use & Care Instructions:	
• Gas Safety and Leak Tests.....	27-29
• Natural Gas Connection.....	30
• Lighting Instructions.....	31
• Troubleshooting.....	32
• Correct Transformer and Light Use.....	33
Cleaning and Maintenance.....	34
Cooking Guide .....	A1-A4
Frequently Asked Questions .....	A5-A6
Warranty Terms.....	Back Cover

### Registered and unregistered Trademarks held by Grand Hall include the following:

Grand Hall and design®, DS Grill and design®, Crossray™ Lateral Infrared Burner Technology, Command Flame®, Smooth Start® Electronic Ignition System, Ceramic Savor Plates®, Sear-zzler®, Stainless Clad Therma-Core® Cooking Grids, Grand Café and design®, Grand Mark and design®, Grand Chef and design®, Grand Royale and design®, Globe Café and design®, Urban Café and design®, Smokeless Grill and design®.

### Patents held by Grand Hall include the following:

The Crossray Burner System by Grand Hall is covered by Australian Patent No. 2006100635, Chinese Patent No. 960361, European Patent No. 1886606, French Patent 0607231, German Patent No. 20 2006 012 212.5, U.K Patent GB2440714, and U.S. Patent 7,475,632.

©2008 Grand Hall. All Rights Reserved.



## WARNING

This appliance, when installed, must be electrically grounded in accordance with local codes or, in the absence of local codes, with the *National Electrical Code, ANSI/NFPA 70*, or the *Canadian Electrical Code, CSA C22.1*.

Keep any electrical supply cord and the fuel supply hose away from any heated surface.



## WARNING

This appliance shall not be used under overhead combustible construction.



## WARNING

1. Do not store or use gasoline or other flammable liquids or vapors in the vicinity of this or any other appliances.
2. An LP cylinder not connected for use shall not be stored in the vicinity of this or any other appliance.



## WARNING

- LPG models must be used with Liquid Propane Gas and the regulator assembly supplied. Natural Gas models must be used with Natural Gas only. Any attempt to convert the grill from one fuel type to another is extremely hazardous and will void the warranty.
- Keep gas regulator hose away from hot grill surfaces and dripping grease. Avoid unnecessary twisting of hose. Visually inspect hose prior to each use for cuts, cracks, excessive wear or other damage. If the hose appears damaged do not use the gas grill. Call **1-877-934-7455** for a certified replacement hose.
- **California Proposition 65**  
Combustion byproducts produced when using this product contain chemicals known to the State of California to cause cancer, birth defects, or other reproductive harm.
- Brass components on the grill, such as hose fittings, propane cylinder valves (sold separately) and burner valve stems, contain lead which is known to the State of California to cause cancer, birth defects, or other reproductive harm.
- **Never use charcoal** or lighter fluid in this gas grill. Failure to comply with these instructions could result in a grease fire or explosion that could cause serious bodily injury, death or property damage.
- The Grease Tray must be visually inspected before each grill use. Remove any grease and wash Grease Tray with a mild soap and warm water solution. **Failure to comply with these instructions could result in a grease fire or explosion that could cause serious bodily injury, death or property damage.**



## DANGER

If you smell gas:

1. Shut off gas to the appliance.
2. Extinguish any open flame.
3. Open lid.
4. If odor continues, keep away from the appliance and immediately call your gas supplier or your fire department.

# Pre-Assembly Instructions For Your Safety

Congratulations on your selection of one of the finest outdoor kitchen appliances available. Your Grill is equipped with the unique Crossray Infrared Cooking System® by Grand Hall, which offers restaurant style grilling performance.

Infrared grilling technology cooks the food directly (and not the air around it) which offers many advantages over conventional grilling systems:

- MORE FLAVORFUL FOOD** as the intense heat sears the food and locks in the juices while also cooking it faster which usually means more succulence.
- FEWER FLAREUPS** as the higher infrared heat vaporizes more drippings which also adds natural flavoring to your food.
- MORE EFFICIENCY AND CONVENIENCE** as the higher heat means shorter cooking times, more fuel efficiency and easier year round grilling.

To begin your “restaurant quality” grilling, become familiar with all of the cooking elements of your Grand Hall Grill lighting and operating instructions.

US Patented No.: 7,475,632  
 European Patent No. 1886606  
 Australia Patent No.: 2006100635  
 Germany Patent No.: 202006012212.5  
 France Patent No.: 0607231  
 UK Patent No.: GB2440714  
 China Patent No.: 960361

**WARNING:** Grease can get very hot. Always handle the Grease Tray with a flame retardant BBQ mitt. Before removing the Tray, always be sure that the grill has properly cooled. Be aware that the tray does contain grease and be extremely careful when removing the tray to prevent spillage. Failure to follow these instructions could cause serious bodily injury or property damage.

## PRE-ASSEMBLY

Read and perform the following pre-assembly instructions:

- Tools Required for Assembly:**
  - protective work gloves
  - protective eyewear
  - Phillips Head screwdriver
- You will need assistance from another person to handle the grill head and other large, heavy parts.
- Open Lid of shipping carton. Remove top sheet of cardboard and packing materials. Lay cardboard sheet on floor and use as a work surface to protect floor and grill parts from scratches.
- You may slice the carton front corners with a utility knife to lay open the carton front panel. This allows you to raise the Lid and remove the components packed inside, making it easier to lift.
- Use the Hardware and Part Diagrams to ensure all items are included and free of damage.
- Do not assemble or operate the grill if it appears damaged. If there are damaged or missing parts when you unpack the shipping box or you have questions during the assembly process call: **1-877-934-7455 M-F 8AM-4:30PM CST** for assistance.

## Grill Installation Codes

The installation must conform with local codes or, in the absence of local codes, with either the National Fuel Gas Code, ANSI Z223.1/NFPA 54, Natural Gas and Propane Installation Code, CSA B149.1, or Propane Storage and Handling Code, B149.2.

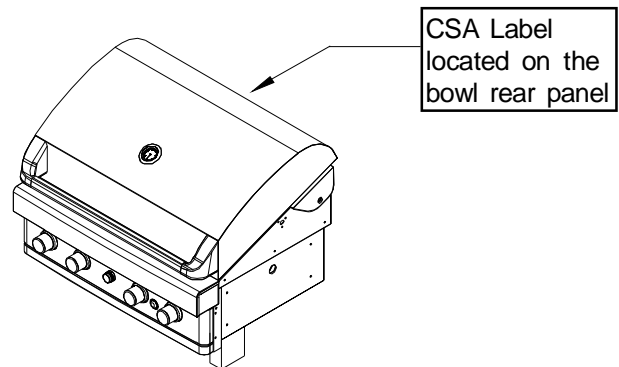

### CAUTION

To reduce the chance of **FLASHBACK FIRE** you must clean the Burner Tubes at least once a month in summer and fall or whenever spiders are active in your area, and if your grill has not been used for an extended period of time.

### WARNING

**Never** cover or wrap the Cooking Grids, bottom of the Grill Bowl, or Grease Tray with aluminum foil or any other material that will absorb grease.

## Hardware Parts List for Models OB2610ALP/NG & OB3210ALP/NG

PART #	PART DESCRIPTION	QTY	PURPOSE OF PART
P06006078A	Hardware Pack	1	For use in assembly of Model OB3210ALP, OB2610ALP, OB3210ANG & OB2610ANG
S182G03061	Pan Head Screw 3/16" x 3/8"	2	Install the Control Box
S182G03061	Pan Head Screw 3/16" x 3/8"	2	Install the Transformer Bracket
S182G03061	Pan Head Screw 3/16" x 3/8"	2	Install the Bracket with LP Regulator (Model OB3210ALP, OB2610ALP Only)
S182G03061	Pan Head Screw 3/16" x 3/8"	3	Install the Tank Tray Set onto the Bottom Panel (Model OB3210ALP, OB2610ALP Only)
S182G03061	Pan Head Screw 3/16" x 3/8"	3	Install the Bracket with NG Regulator (Model OB3210ANG, OB2610ANG Only)

## Hardware Diagram for Models OB2610ALP/NG & OB3210ALP/NG



Pan Head Screw  
 3/16"x3/8"  
 Qty. 9 (For OB2610ALP & OB3210ALP Models)  
 Qty. 7 (For OB2610ANG & OB3210ANG Models)  
 Part # S182G03061

\*One Battery/AA and Four Battery/AAA included in the Hardware Pack.

## Hardware Parts List for Models OB3210BLP/NG

PART #	PART DESCRIPTION	QTY	PURPOSE OF PART
P06006080A	Hardware Pack	1	For use in assembly of Model OB3210BLP/NG
S182G03061	Pan Head Screw 3/16" x 3/8"	4	Install Cabinet Bottom Panel
S182G03061	Pan Head Screw 3/16" x 3/8"	2	Install Cabinet Rear Panel
S185G03061	Bolt 3/16" x 3/8"	6	Install Partition Panel to Cabinet Panels
S182G03061	Pan Head Screw 3/16" x 3/8"	3	Install Tank Holder
S182G03061	Pan Head Screw 3/16" x 3/8"	8	Install Grill Bowl to Cabinet
S182G03061	Pan Head Screw 3/16" x 3/8"	2	Install Control Box
S182G03061	Pan Head Screw 3/16" x 3/8"	2	Install Transformer Bracket
S182G03061	Pan Head Screw 3/16" x 3/8"	3	Install NG Regulator Assembly Bracket
S182G03081	Pan Head Screw 3/16" x 1/2"	2	Install Side Shelf
S182G03061	Pan Head Screw 3/16" x 3/8"	4	Install Upper Door Bracket
S142G0306A	Countersunk Flat Head Screw 3/16" x 3/8"	4	Install Lower Door Bracket
P05515015L	Wrench	1	Adjust Cart Leg

## Hardware Diagram for Models OB3210BLP/NG



Pan Head Screw  
3/16"x3/8"  
Qty. 28  
Part # S182G03061

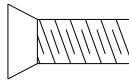

Countersunk Flat Head  
Screw 3/16"x3/8"  
Qty. 4  
Part # S142G0306A



Pan Head Screw  
3/16"x1/2"  
Qty. 2  
Part # S182G03081

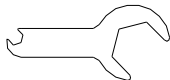

Wrench  
Qty. 1  
Part # P05515015L

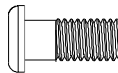

Bolt  
3/16"x3/8"  
Qty. 6  
Part # S185G03061

# Parts Diagram for Models OB2610ALP/NG-Grill

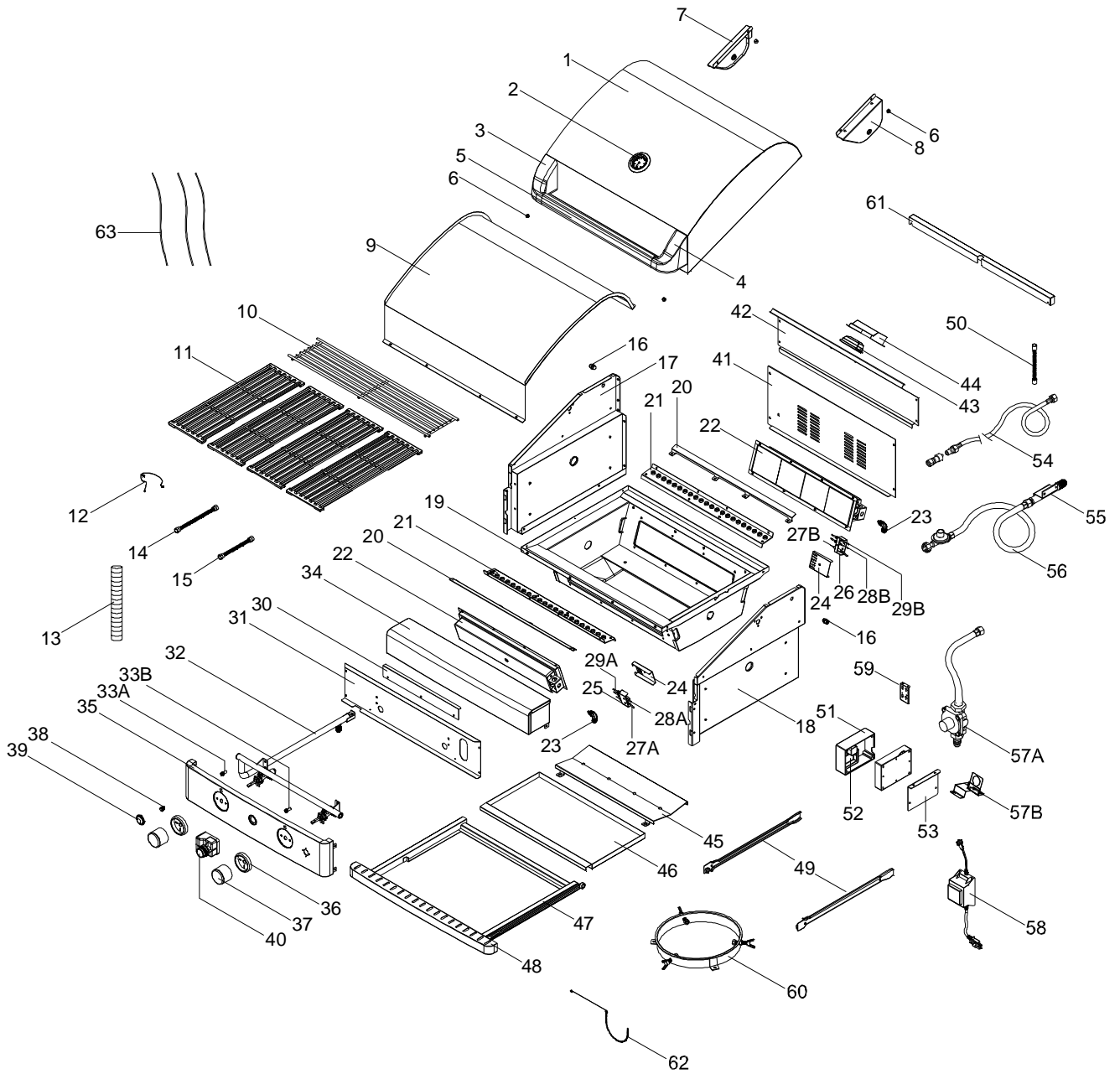

## Parts List for Models OB2610ALP/NG-Grill

KEY	DESCRIPTION	OB2610ALP/NG PART#	QTY
1	Lid Assembly	P0014633AA	1
2	Temperature Gauge	P00601381A	1
3	Lid Handle Bracket, Left	P00307058E	1
4	Lid Handle Bracket, Right	P00308058E	1
5	Lid Handle	P00215037H	1
6	Protective Pad	P05518002I	4
7	Lid Assembly Bracket, Left	P03320007C	1
8	Lid Assembly Bracket, Right	P03320008C	1
9	Lid Trim Plate	P0014635QJ	1
10	Cooking Rack/Secondary	P015140222	1
11	Cooking Grid	P01615038H	4
12	Electric Wire Set	P02627013A	1
13	Electric Wire Protector	P055330043	1
14	Connection Hose - Long	P03702037D	1
15	Connection Hose - Short	P03702039D	1
16	Lid Hinge with Nut	P05501136L	2
17	Bowl Side Panel, Left	P0076113EC	1
18	Bowl Side Panel, Right	P0076213EC	1
19	Bowl	P0071389EC	1
20	Grease Shield, Upper	P06902133C	2
21	Grease Shield, Lower	P06902135C	2
22	Infrared Burner Assembly	P02005028B	2
23	Extension Fitting with Orifice (LPG)	P06539030A	2
	Extension Fitting with Orifice (NG)	P06539031A	2
24	Thermocouple Protector	P03343023C	2
25	Thermocouple Bracket	P03327082C	1
26	Thermocouple Bracket	P03327083C	1
27A	Electrode, Front	P02618058A	1
27B	Electrode, Rear	P02618059A	1
28A	Thermocouple for Gas Valve, Front	P05305055B	1
28B	Thermocouple for Gas Valve, Rear	P05305061B	1
29A	Thermocouple for LED Light, Front	P05305066B	1
29B	Thermocouple for LED Light, Rear	P05305065B	1
30	Control Panel Heat Shield Bracket	P0300615FD	1
31	Control Panel Heat Shield	P0300723AA	1
32	Gas Valve/Manifold Assembly (LPG)	Y0060677	1
	Gas Valve/Manifold Assembly (NG)	Y0060678	1
33A	LED Light with Wire - A	P02615159A	1
33B	LED Light with Wire - B	P02615167A	1
34	Bowl Front Trim Plate Assembly	P02913627S	1
35	Control Panel	P02913633X	1
36	Control Knob Seat	P03439014A	2
37	Control Knob	P03436053V	2
38	Switch for LED Light	P05360001B	1
39	Switch Cover for Light	P05382004P	1
40	Electric Ignitor, 2-Port	P02502392C	1
41	Bowl Panel, Rear/Lower	P0073743BC	1
42	Bowl Panel, Rear/Upper (LPG)	P0073745BC	1
	Bowl Panel, Rear/Upper (NG)	P0073746BC	1
43	Lamp, 12V, 10W	P05352012B	1
44	Lamp Cover	P05352013E	1
45	Grease Tray Heat Shield	P06903069C	1
46	Grease Tray	P02717813C	1

## Parts List for Models OB2610ALP/NG-Grill

KEY	DESCRIPTION	OB2610ALP/NG PART#	QTY
47	Grease Tray Bracket	Y0270027	1
48	Grease Tray Handle	P0272012CC	1
49	Grease Tray Slide Set	P05516140M	2
50	Lamp Wire Set Protector	P055330103	1
51	Control Box	P05545006M	1
52	LED Light Controller	P05357021B	1
53	Control Box Bracket	P03343022C	1
54	Hose, 12 FT, NG	P03703001A	1
55	Regulator Hose Connector(LPG)	P03901046D	1
56	Regulator with Hose (LPG)	P03603049A	1
57A	Regulator with Hose (NG)	Y0080039	1
57B	Regulator Bracket (NG)	P033110415	1
58	Transformer	P05374015B	1
59	Transformer Bracket	P03328057A	1
60	Tank Tray Set (LPG)	Y0340050	1
61	Trim Panel, Rear	P07515025R	1
62	Lighting Stick	P05507140M	1
63	Lamp Wire Set	P05352015B	1
	Operator's Manual	P80151123A	1

# Parts Diagram for Models OB3210ALP/NG & OB3210BLP/NG-Grill

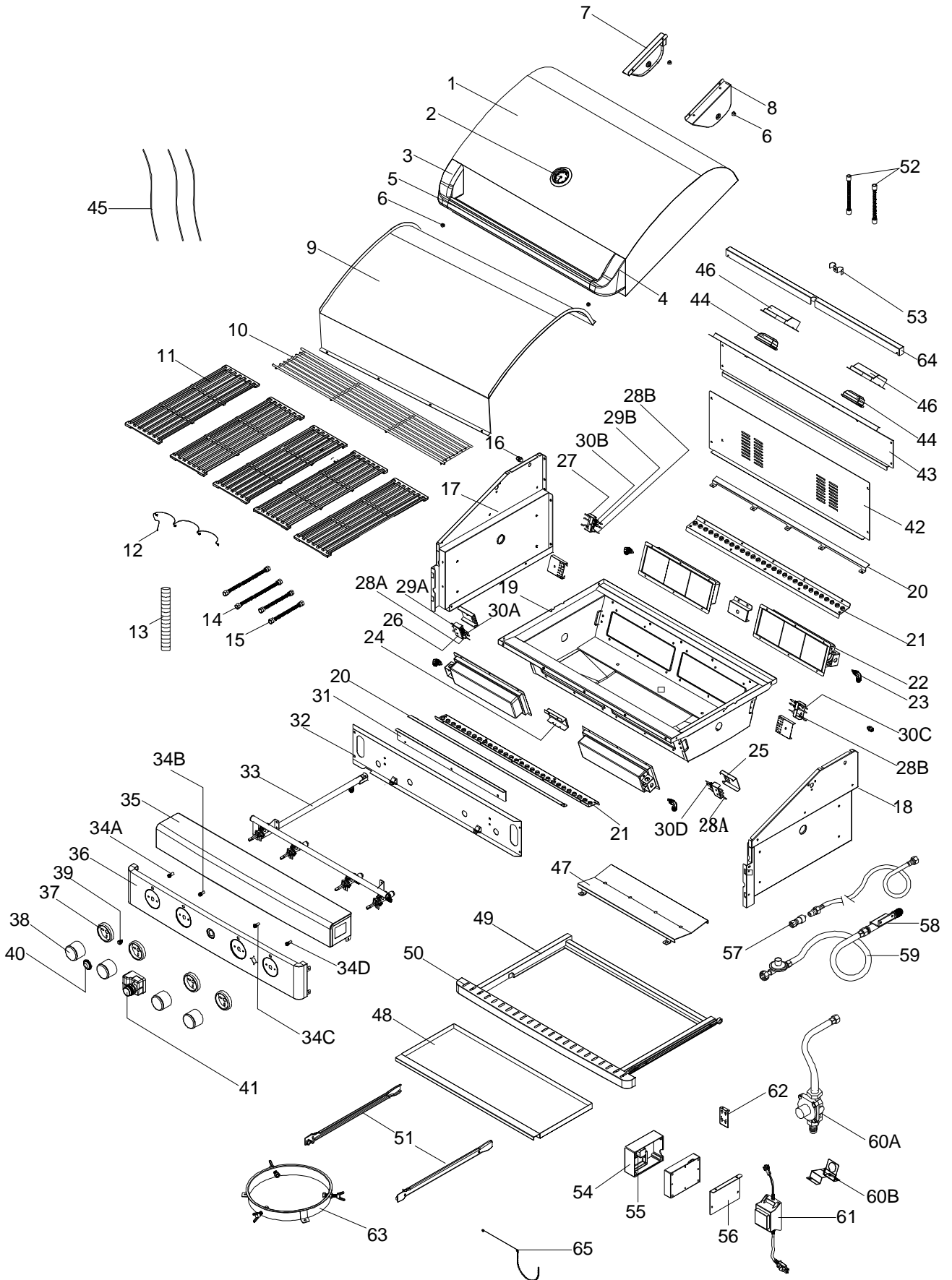

## Parts List for Models OB3210ALP/NG & OB3210BLP/NG-Grill

KEY	DESCRIPTION	OB3210ALP/NG PART#	OB3210BLP/NG PART#	QTY
1	Lid Assembly	P0014734AA	P0014734AA	1
2	Temperature Gauge	P00601381A	P00601381A	1
3	Lid Handle Bracket, Left	P00307058E	P00307058E	1
4	Lid Handle Bracket, Right	P00308058E	P00308058E	1
5	Lid Handle	P00215036H	P00215036H	1
6	Protective Pad	P05518002I	P05518002I	4
7	Lid Assembly Bracket, Left	P03320007C	P03320007C	1
8	Lid Assembly Bracket, Right	P03320008C	P03320008C	1
9	Lid Trim Plate	P0014735QJ	P0014735QJ	1
10	Cooking Rack/Secondary	P015160282	P015160282	1
11	Cooking Grid	P01615038H	P01615038H	5
12	Electric Wire Set	P02627014A	P02627014A	1
13	Electric Wire Protector	P055330043	P055330043	1
14	Connection Hose - Long	P03702037D	P03702037D	2
15	Connection Hose - Short	P03702038D	P03702038D	2
16	Lid Hinge with Nut	P05501136L	P05501136L	2
17	Bowl Side Panel, Left	P0076113EC	P0076113EC	1
18	Bowl Side Panel, Right	P0076213EC	P0076213EC	1
19	Bowl	P0071388EC	P0071388EC	1
20	Grease Shield, Upper	P06902131C	P06902131C	2
21	Grease Shield, Lower	P06902132C	P06902132C	2
22	Infrared Burner Assembly	P02005027B	P02005027B	4
23	Extension Fitting with Orifice (LPG)	P06539032A	P06539032A	4
	Extension Fitting with Orifice (NG)	P06539033A	P06539033A	4
24	Cross Lighting Channel	P02212377A	P02212377A	2
25	Thermocouple Protector	P03343017C	P03343017C	4
26	Thermocouple Bracket	P03327082C	P03327082C	2
27	Thermocouple Bracket	P03327083C	P03327083C	2
28A	Electrode, Front	P02618056A	P02618056A	2
28B	Electrode, Rear	P02618057A	P02618057A	2
29A	Thermocouple for Gas Valve	P05305054B	P05305054B	2
29B	Thermocouple for Gas Valve	P05305055B	P05305055B	2
30A	Thermocouple for LED Light, Left Front	P05305056B	P05305056B	1
30B	Thermocouple for LED Light, Left Rear	P05305057B	P05305057B	1
30C	Thermocouple for LED Light	P05305058B	P05305058B	1
30D	Thermocouple for LED Light	P05305059B	P05305059B	1
31	Control Panel Heat Shield Bracket	P0300616FD	P0300616FD	1
32	Control Panel Heat Shield	P06904056C	P06904056C	1
33	Gas Valve/Manifold Assembly (LPG)	Y0060679	Y0060679	1
	Gas Valve/Manifold Assembly (NG)	Y0060680	Y0060680	1
34A	LED Light with Wire - A	P02615155A	P02615155A	1
34B	LED Light with Wire - B	P02615156A	P02615156A	1
34C	LED Light with Wire - C	P02615157A	P02615157A	1
34D	LED Light with Wire - D	P02615158A	P02615158A	1
35	Bowl Front Trim Plate Assembly	P02915341S	P02915341S	1
36	Control Panel	P02915553X	P02915553X	1
37	Control Knob Seat	P03439014A	P03439014A	4
38	Control Knob	P03436053V	P03436053V	4
39	Switch for LED Light	P05360001B	P05360001B	1
40	Switch Cover for Light	P05382004P	P05382004P	1
41	Electric Ignitor, 4-Port	P02502384C	P02502384C	1
42	Bowl Panel, Rear/Lower	P0073740BC	P0073740BC	1
43	Bowl Panel, Rear/Upper (LPG)	P0073741BC	P0073741BC	1
	Bowl Panel, Rear/Upper (NG)	P0073742BC	P0073742BC	1
44	Lamp, 12V, 10W	P05352012B	P05352012B	2
45	Lamp Wire Set	P05352014B	P05352014B	1
46	Lamp Cover	P05352013E	P05352013E	2

## Parts List for Models OB3210ALP/NG & OB3210BLP/NG-Grill

KEY	DESCRIPTION	OB3210ALP/NG PART#	OB3210BLP/NG PART#	QTY
47	Grease Tray Heat Shield	P06903069C	P06903069C	1
48	Grease Tray	P02717793C	P02717793C	1
49	Grease Tray Bracket	Y0270026	Y0270026	1
50	Grease Tray Handle	P0272011CC	P0272011CC	1
51	Grease Tray Slide Set	P05516140M	P05516140M	2
52	Lamp Wire Set Protector	P055330103	P055330103	2
53	Lamp Wire Set Protector Bracket	P03328079C	P03328079C	1
54	Control Box	P05545006M	P05545006M	1
55	LED Light Controller	P05357022B	P05357022B	1
56	Control Box Bracket	P03343022C	P03343022C	1
57	Hose, 12 FT, NG	P03703001A	P03703001A	1
58	Regulator Hose Connector (LPG)	P03901046D	N/A	1
59	Regulator with Hose Assembly (LPG)	P03603049A	P03603049A	1
60A	Regulator with Hose (NG)	Y0080039	Y0080039	1
60B	Regulator Bracket (NG)	P033110415	P033110415	1
61	Transformer	P05374015B	P05374015B	1
62	Transformer Bracket	P03328057A	P03328057A	1
63	Tank Tray Set (LPG)	Y0340050	Y0340050	1
64	Trim Panel, Rear	P07515023R	P07515023R	1
65	Lighting Stick	P05507140M	P05507140M	1
	Operator's Manual	P80151123A	P80151123A	1

For the repair or replacement parts you need:  
Call 1-877-934-7455 M-F 8:00AM-4:30 PM CST

To obtain the correct replacement parts for your gas grill, please refer to the part numbers in this parts list. The following information is required to ensure you receive the correct parts:

1. Model and Serial Number (see CSA label on grill)
2. Part Number
3. Part Description
4. Quantity of parts needed

**Important:** Use only Grand Hall replacement parts. The use of any part that is not a Grand Hall replacement part can be dangerous and will also void your product warranty. Keep this Operator's Manual for convenient referral and for part replacement.

# Parts Diagram for Models OB3210BLP/NG-Cabinet

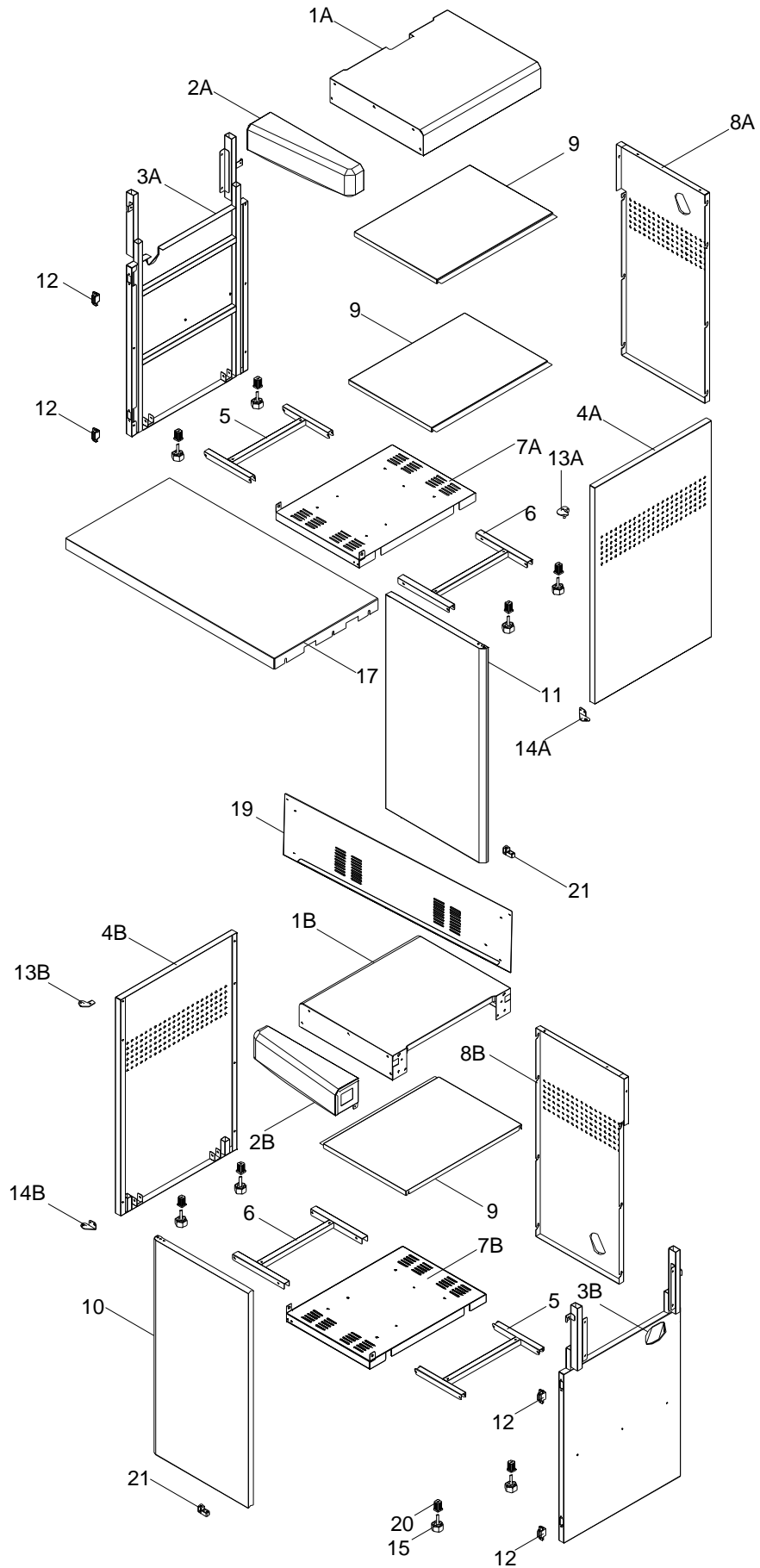

## Parts List for Models OB3210BLP/NG-Cabinet

KEY	DESCRIPTION	OB3210BLP/NG PART#	QTY
1A	Side Shelf, Right	P01107048B	1
1B	Side Shelf, Left	P01106052B	1
2A	Side Shelf Trim Plate, Right	P07503028A	1
2B	Side Shelf Trim Plate, Left	P07503023A	1
3A	Right Cabinet Panel, Left	P07617050B	1
3B	Left Cabinet Panel, Right	P07618050B	1
4A	Right Cabinet Panel, Right	P07618051B	1
4B	Left Cabinet Panel, Left	P07617051B	1
5	Folding Bracket A	P03303147D	2
6	Folding Bracket B	P03303148D	2
7A	Bottom Panel, Right	P01001093D	1
7B	Bottom Panel, Left	P01001095D	1
8A	Right Cabinet Panel, Rear	P07702123B	1
8B	Left Cabinet Panel, Rear	P07702125B	1
9	Partition Panel	P01001096D	3
10	Door Assembly, Left	P04302058A	1
11	Door Assembly, Right	P04203059A	1
12	Door Magnet	P05523056L	4
13A	Door Bracket, Right/Upper	P03313045D	1
13B	Door Bracket, Left/Upper	P03313046D	1
14A	Door Bracket, Right/Lower	P03313047D	1
14B	Door Bracket, Left/Lower	P03313048D	1
15	Level Adjuster	P05322041B	8
17	Outer Partition Panel	P01004058D	1
19	Bowl Panel, Rear/Lower	P0075812BC	1
20	End Cap, Leg	P06802008G	8
21	Door Hinge	Y0550002	2
	Operator's Manual	P80151123A	1

For the repair or replacement parts you need:  
Call 1-877-934-7455 M-F 8:00AM-4:30PM CST

To obtain the correct replacement parts for your gas grill, please refer to the part numbers in this parts list. The following information is required to ensure you receive the correct parts:

1. Model and Serial Number (see CSA label on grill)
2. Part Number
3. Part Description
4. Quantity of parts needed

**Important:** Use only Grand Hall replacement parts. The use of any part that is not a Grand Hall replacement part can be dangerous and will also void your product warranty. Keep this Operator's Manual for convenient referral and for part replacement.

# Assembly Instructions for OB3210BLP/NG

**CAUTION:** While it is possible for one person to assemble this grill, obtain assistance from another person when handling some of the larger, heavier pieces.

## 1 Unfold Left and Right Cabinet

- Open carton and remove all packing materials.
- Unfold the left cabinet as shown.
- Repeat the step for the right cabinet.

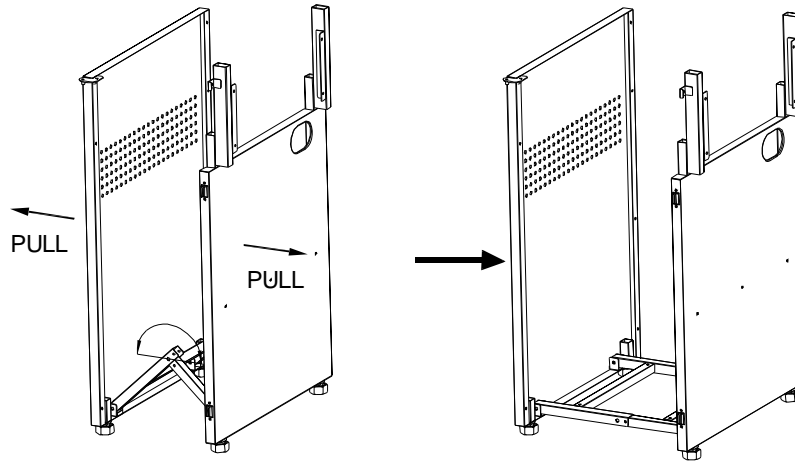

## 2 Install Left & Right Bottom Panel

- Install Left Bottom Panel onto left cabinet using 2 Pan Head Screws 3/16"X3/8" and tighten securely. (as shown below)
- Repeat the step for right cabinet.



Pan Head Screw  
3/16"x3/8"  
Qty. 4  
Part # S182G03061

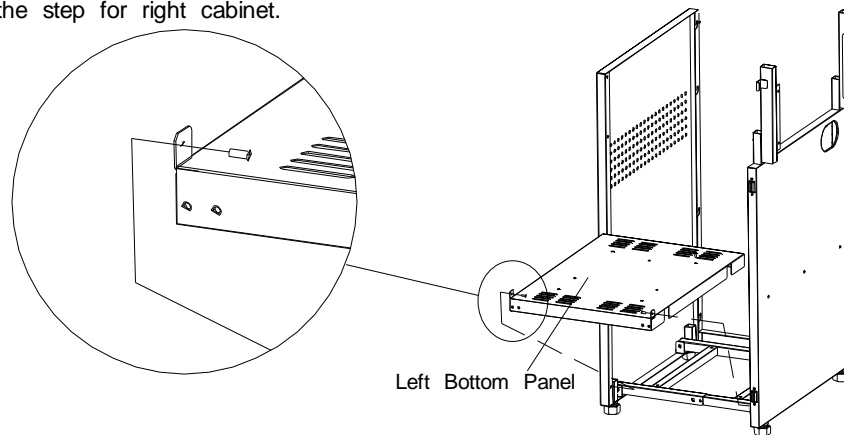

Left Bottom Panel

## 3 Install Left & Right Rear Panel

- Place the Left Rear Panel over the installed bolt of the left cabinet. (see Fig. 1)
- Secure the Left Rear Panel to left cabinet use 1 Pan Head Screw 3/16"x3/8". (see Fig. 2)
- Repeat the step for right cabinet.



Pan Head Screw  
3/16"x3/8"  
Qty. 2  
Part # S182G03061

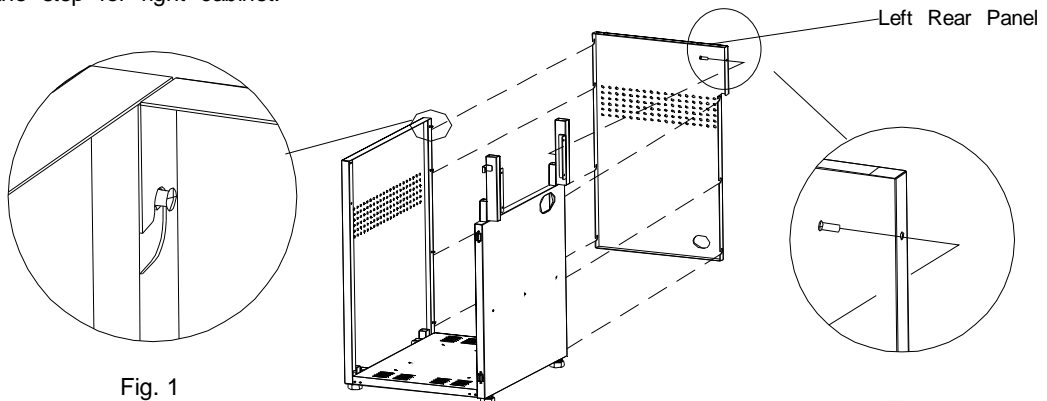
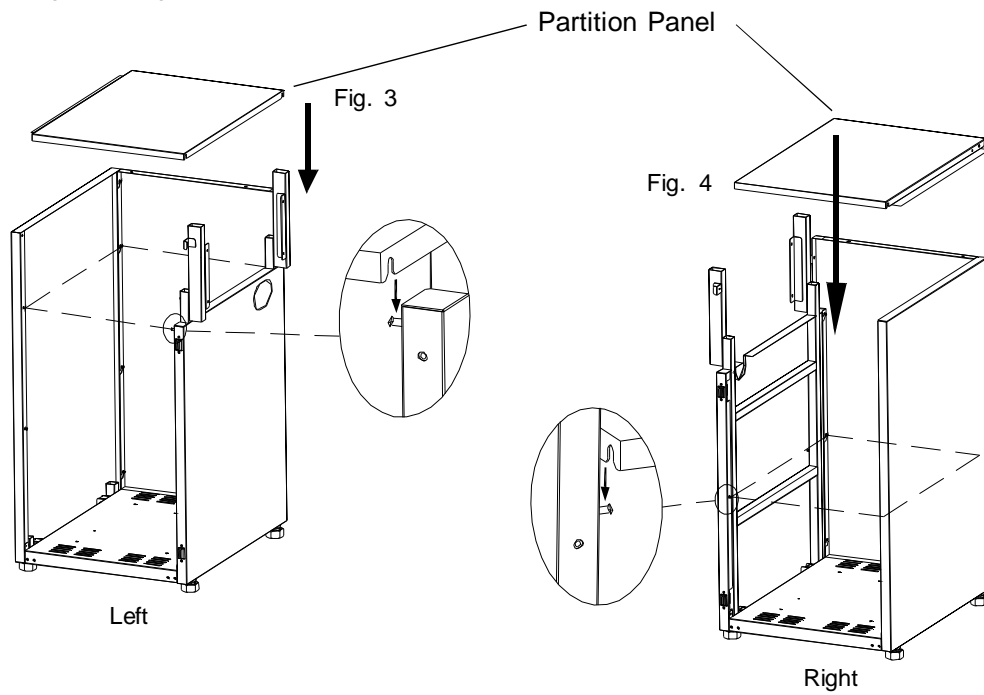

Fig. 1

Fig. 2

## 4 Install Partition Panel

- Place Partition Panel over the bolts of left cabinet and right cabinet. (the bolts are already installed) (see Fig. 3 & Fig. 4)



## 5 Install Outer Partition Panel

- Install 6 Bolts 3/16"x3/8" to left and right cabinet, then place the Outer Partition Panel over the bolts. (as shown below)

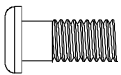

Bolt  
3/16"x3/8"  
Qty. 6  
Part # S185G03061

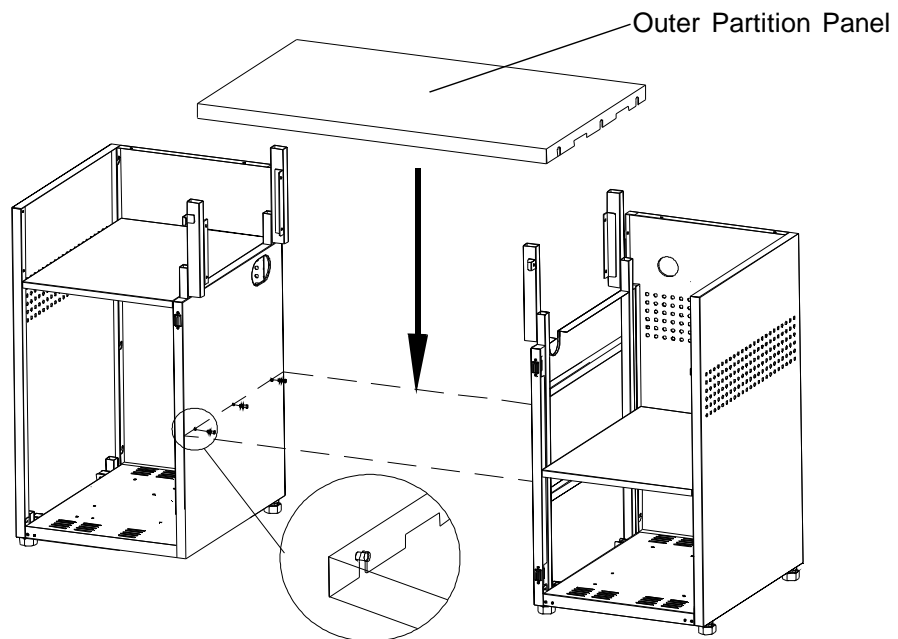

## 6

### Install Grill Bowl and Tank Holder (Tank Holder is only for LP Model)

- Make sure all cooking components are removed from the Grill Bowl. Lift and position the Grill Bowl over the Support Brackets.
- Note:** Make sure the Control Box wire goes through the "U" shaped hole on right cabinet.(as shown)
- Align the holes on the Grill Bowl with the holes on the Support Brackets using 8 Pan Head Screws 3/16"x3/8" and tighten securely.
- Install Tank Holder onto the Left Bottom Panel using 3 Pan Head Screws 3/16"x3/8" and tighten securely.(only for LP model)

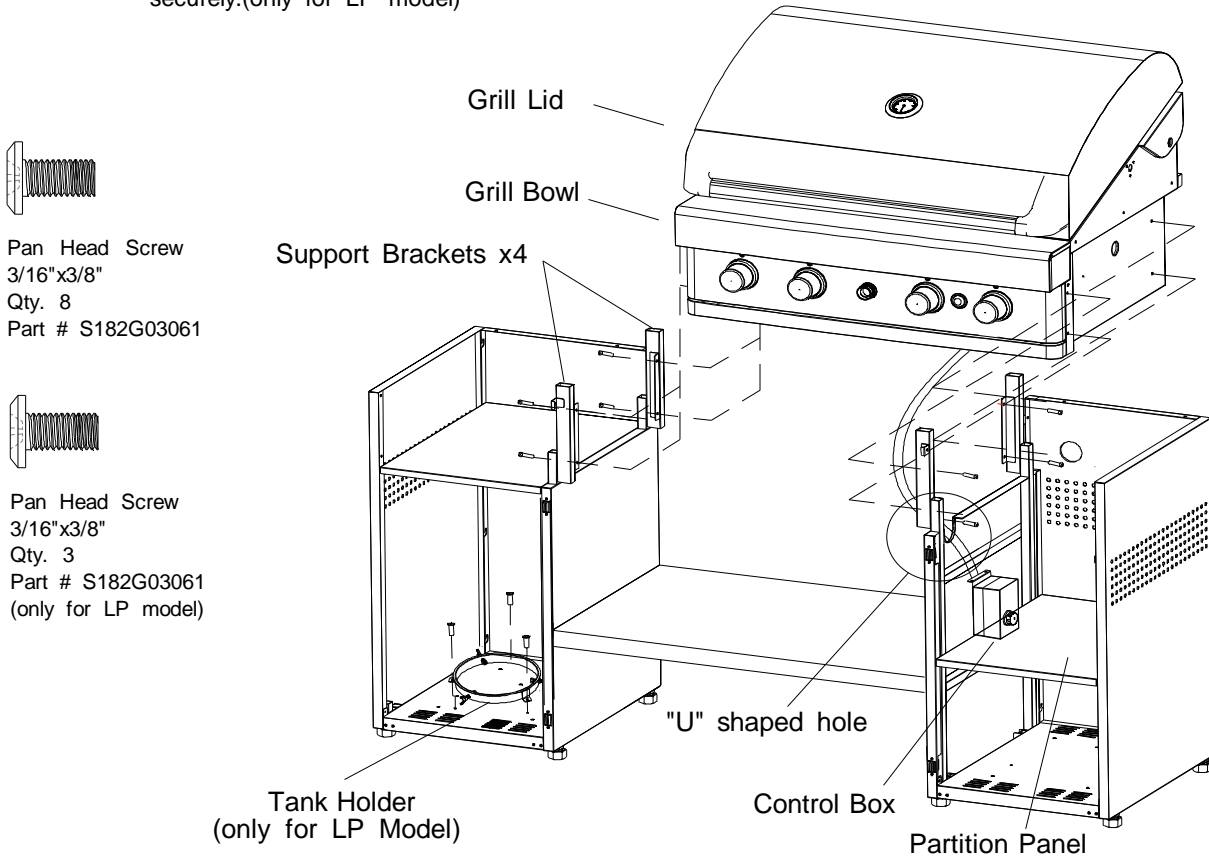

## 7

### Install Transformer Bracket onto the Right Cabinet Partition Panel(refer to step 8)

- Install Transformer Bracket onto the Partition Panel using 2 Pan Head Screws 3/16"x3/8" and tighten securely as shown below.

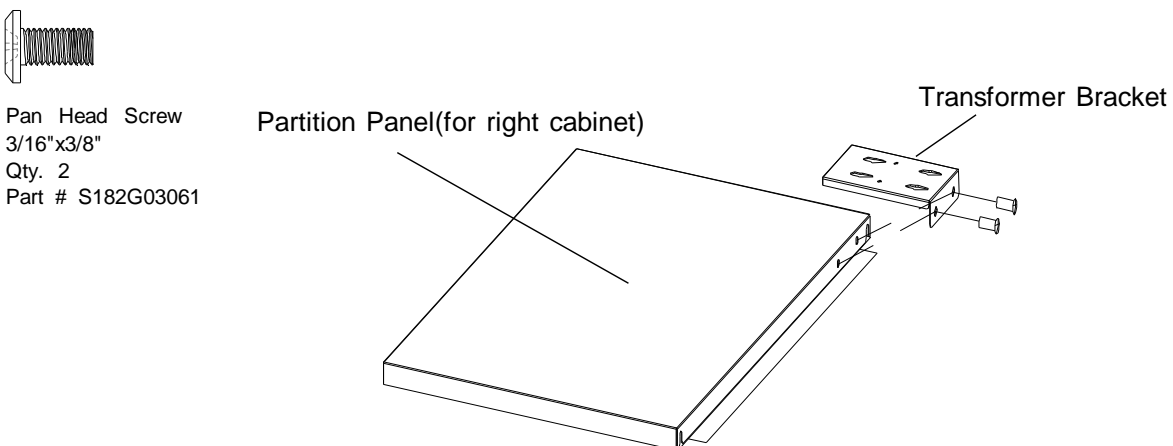

# 8

## Install Control Box, Partition Panel, Transformer and Batteries

- **Install Control Box:** Align the holes in the Control Box bracket with the holes in the right cabinet using 2 Pan Head Screws 3/16"x3/8" and tighten securely. (see Fig. 1)
- **Install Partition Panel:** Place Partition Panel with Transformer Bracket over the bolts of the right cabinet.(similar to step 4)
- **Install Transformer:** Install Transformer onto the Transformer Bracket by putting the four pre-assembled screws on the Transformer into the four holes on the Transformer Bracket. Press the Transformer downward until the screws rest in place. (see Fig. 2)
- Install Transformer-Plug into Transformer-Socket and tighten securely. (See Fig.3)
- Plug the Transformer into the power source. Push the Lamp Switch on the Control Panel to turn on the Grill lamps.
- **Install Batteries:** Place 1 AA battery into the slot of the Control Panel and 4 AAA batteries into the slot of the Control Box as show below. Position the caps onto the slots, and tighten securely.  
**Note:** The positive pole of the AA battery must face towards the cap. For the AAA batteries, 2 batteries must have the positive pole facing towards the cap and 2 batteries must have the negative poles facing away from the caps.)

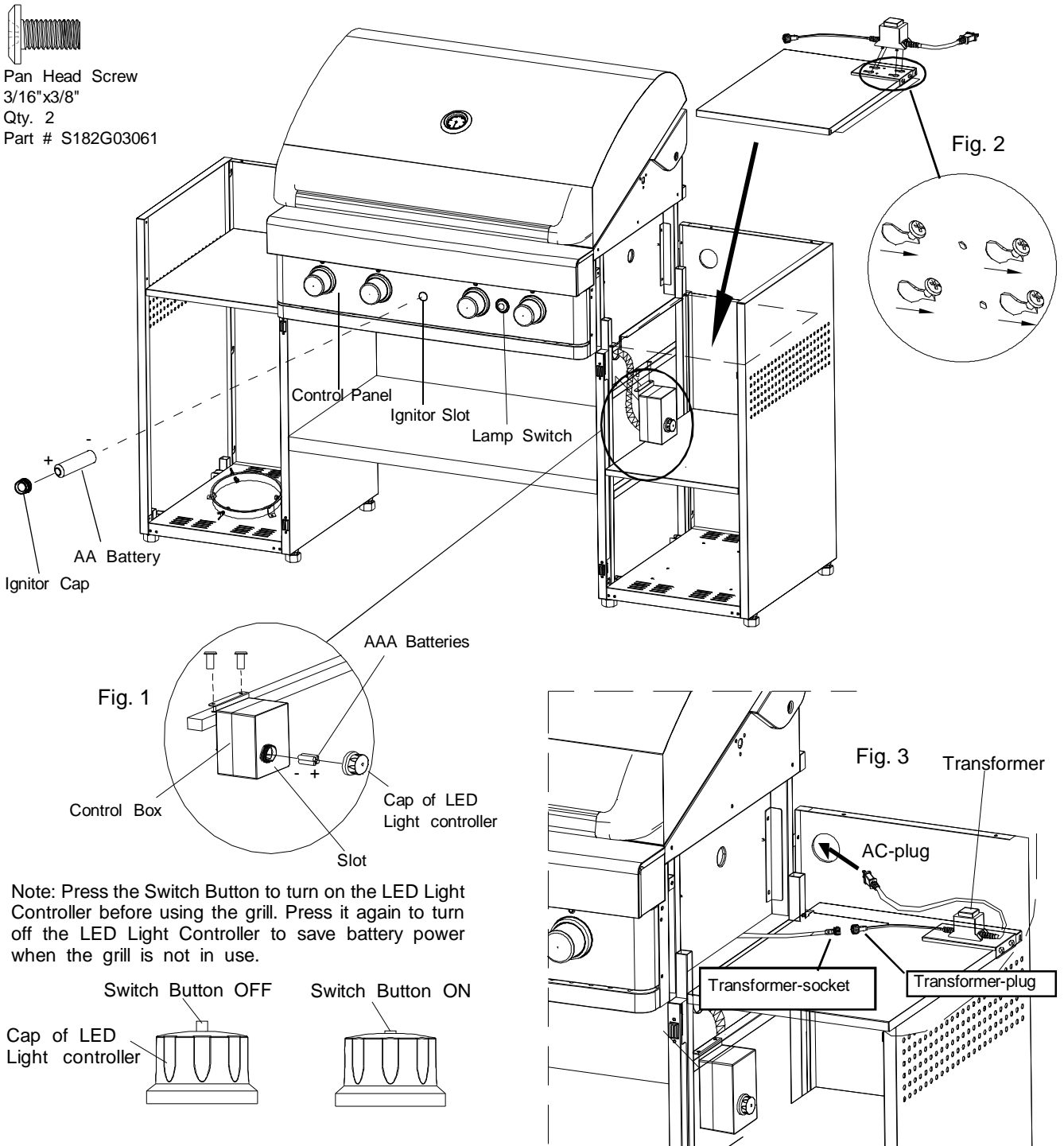

## 9A Remove Hose Connector and Install LP Regulator (only for OB3210BLP Model)

- Remove the Regulator Hose Connector from the LP Regulator Hose. (see Fig.1)
- Connect the LP Regulator Hose to the Gas manifold. (see Fig. 2)

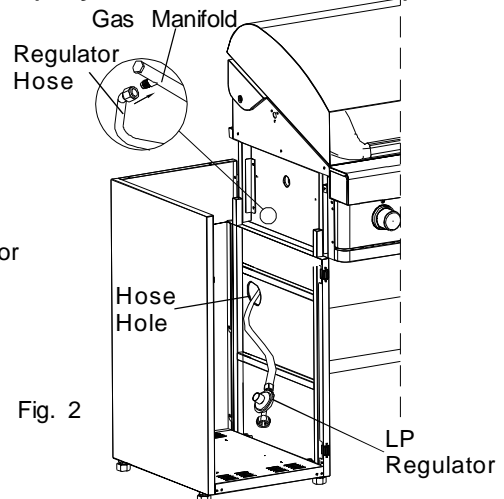
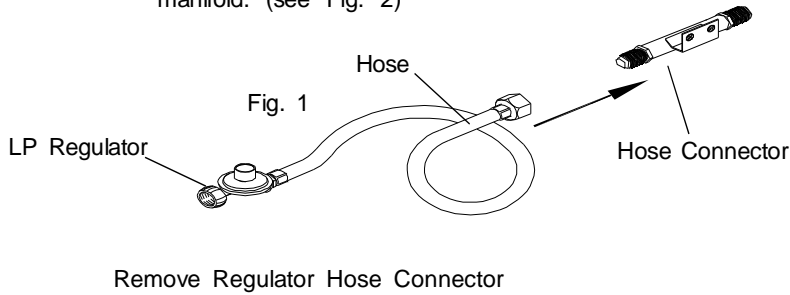

## 9B Install NG Regulator(only for OB2610ANG, OB3210ANG and OB3210BNG)

- Install NG Regulator Bracket onto left cabinet using 3 Pan Head Screws 3/16"x3/8".
- Connect the NG Connecting Hose to the Gas manifold. (see Fig. 3)



Pan Head Screw  
3/16"x3/8"  
Qty. 3  
Part # S182G03061

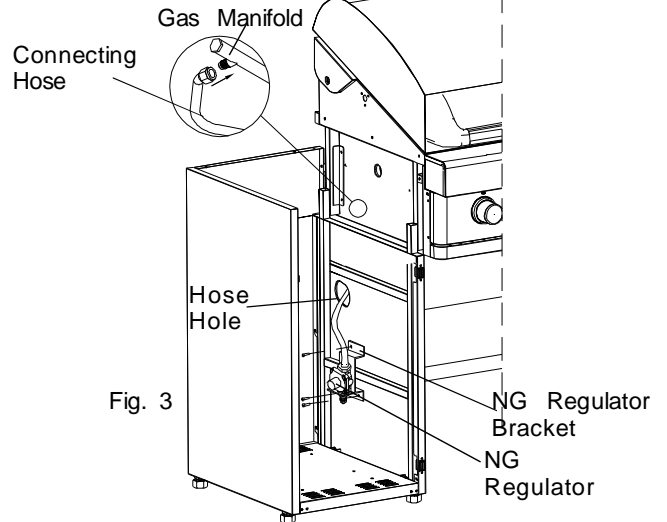

## 10 Install Cabinet Right & Left Side Shelf

- Place the Right Side Shelf over the bolts on the Cabinet Rear Panel. Then slide the Right Side Shelf from the back to the front. ①
- Secure the Right Side Shelf to Grill Bowl Right Panel using 1 Pan Head Screw 3/16"x1/2". ②
- Repeat Steps for the Left Side Shelf.



Pan Head Screw  
3/16"x1/2"  
Qty. 2  
Part # S182G03081

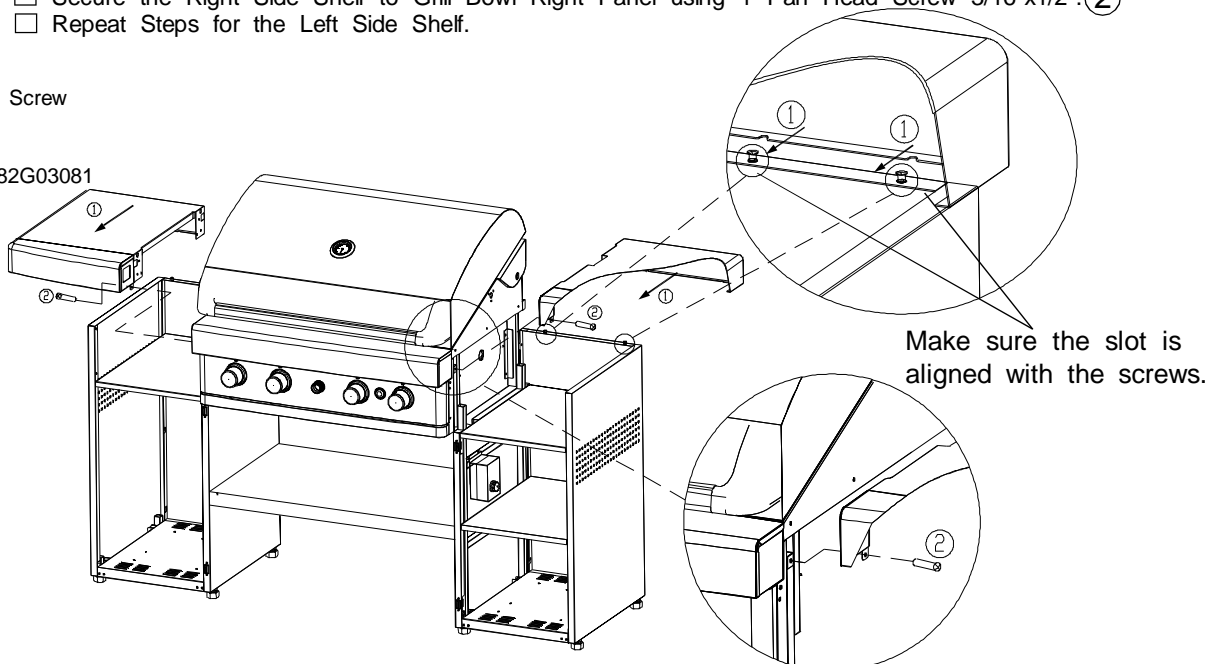

# 11

## Install Upper & Lower Door Bracket and Doors

- Install 2 Upper Door Brackets onto left and right cabinet using 4 Pan Head Screws 3/16"x 3/8" and tighten securely. (see Fig.1)
- Install 2 Lower Door Brackets onto left and right cabinet using 4 Countersunk Flat Head Screws 3/16"x 3/8" and tighten securely. (see Fig. 2)
- Note:** The Upper & Lower Door Bracket for the left side is marked with an "L". The Upper & Lower Door Bracket for the right side is marked with an "R".
- If the Cabinet Sets are not level with each other, use the wrench to adjust the level adjusters on the bottom of the cabinet side panels. (see Fig. 3)
  - Turn the adjusters clockwise to raise the height of the Grill.
  - Turn the adjusters counterclockwise to lower the height of the Grill.
- FOR YOUR SAFETY: DO NOT TILT your Grill at any time.**
- Match the Door Upper hole to the Upper Door Bracket shaft. (see Fig. 4) Slide or press the spring on the bottom of the door to position the Door into the Lower Bracket.



Pan Head Screw  
3/16"x3/8"  
Qty. 4  
Part # S182G03061

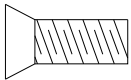

Countersunk Flat Head  
Screw 3/16"x3/8"  
Qty. 4  
Part # S142G03061

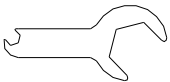

Wrench  
Qty. 1  
Part # P05515015L

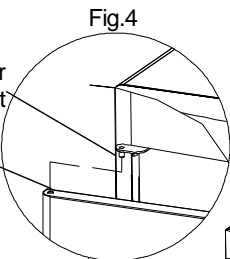
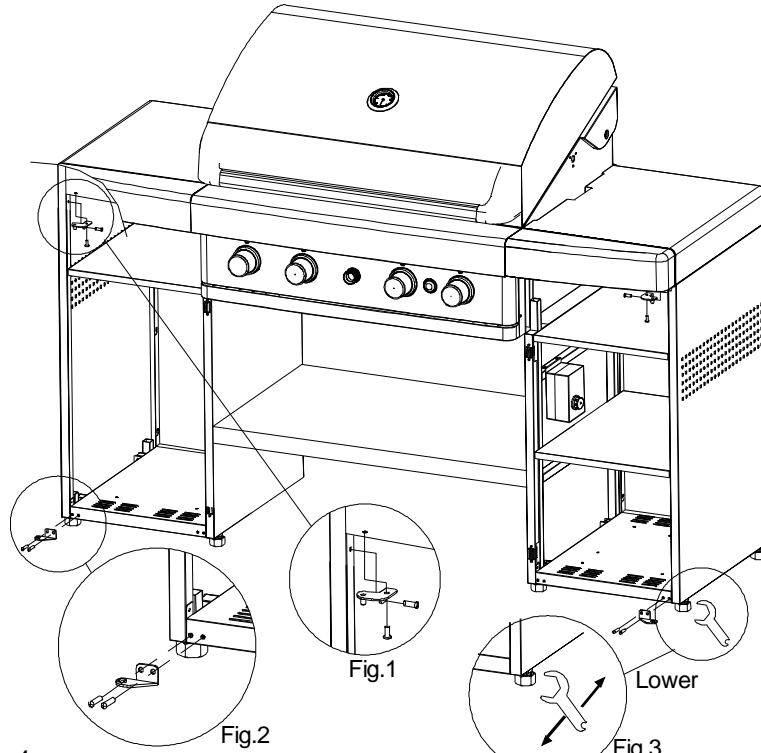

Upper Door  
Bracket shaft  
Door Upper Hole

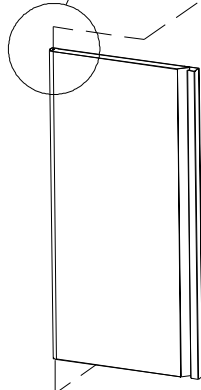

Lower Door Bracket

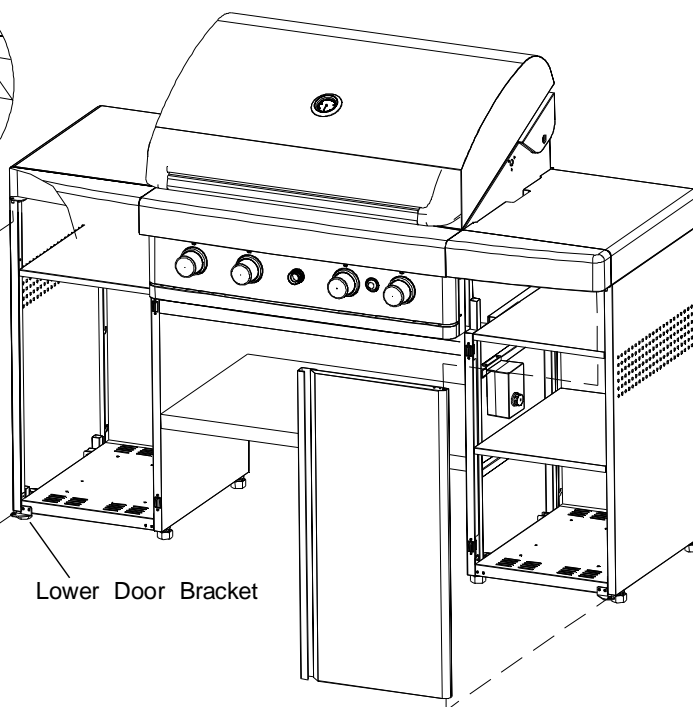

## 12A Replace Rear Lower Bowl Panel (only for OB3210B Model)

- Unscrews and remove the Rear Lower Bowl Panel and the Rear Trim Panel from the back of the Grill Bowl. (see Fig. 1)
- Install the new Rear Lower Bowl Panel onto the back of the Grill Bowl using the same screws and tighten securely. (see Fig.2) (do not reinstall the Rear Trim panel)

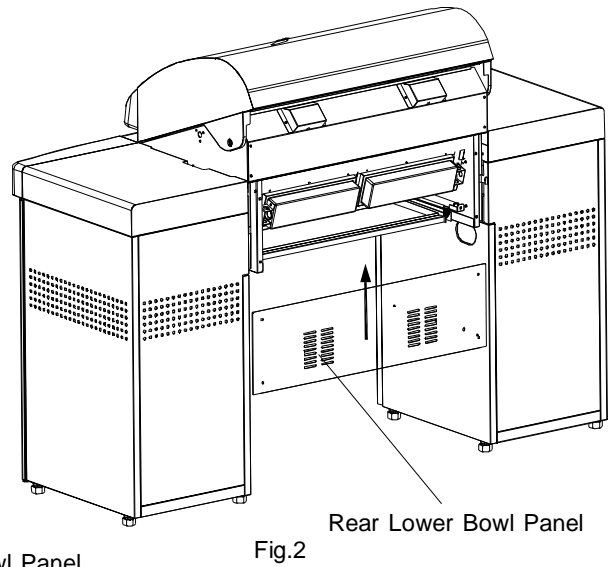
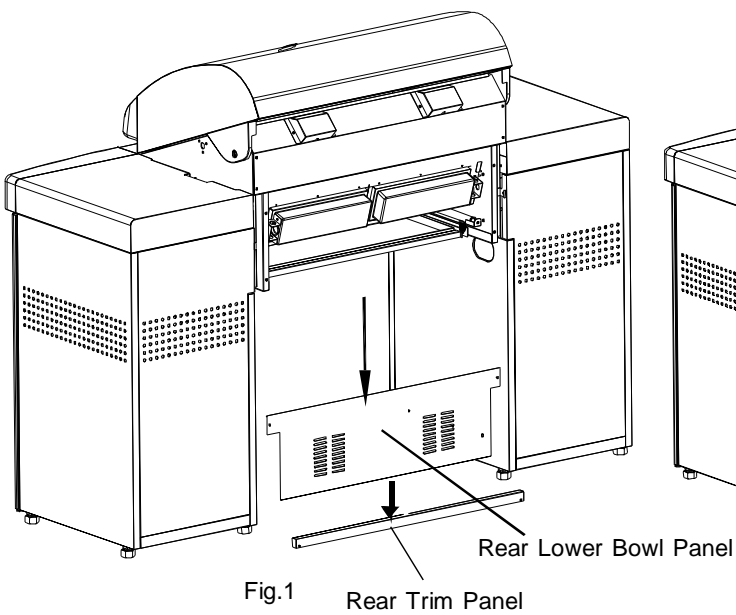

## 12B Grease Tray

- Pull out the Grease Tray Bracket. Place the Grease Tray into the Grease Tray Bracket. (as show below) Push the Grease Tray Bracket back into position.

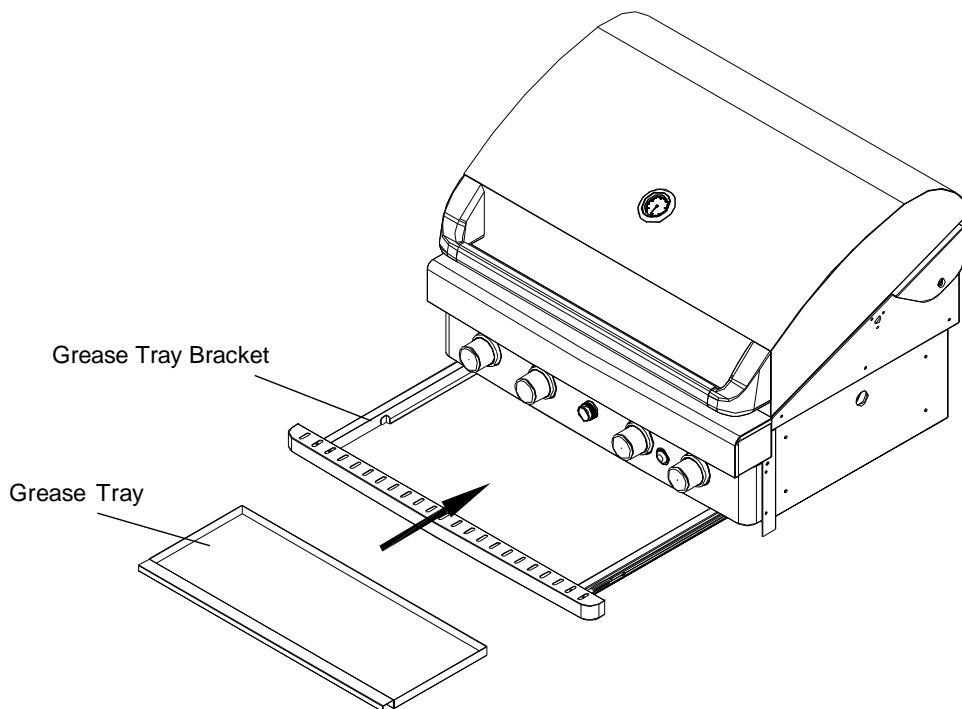

### 13 Burner Electrode Check Perform this Electrode Check with the assistance of another person

This test will ensure that the Spark Electrode Tips are properly positioned so your grill lights easily and properly.

- Be sure all Control Knobs are set to "OFF" and open the Grill Lid.
- Have your assistant stand behind you to the right of the grill and look at both the front and rear burner locations of the grill bowl. **Never** put your face inside the Grill Bowl.
- Turn any Control Knob of Burners to ⚡ and push in and have assistant watch for a blue spark within each Ignition Electrode.
- If no spark is seen, the Spark Gap needs to be adjusted as follows:
  - If the gap between the Spark Electrode Tip and Receiver is more than 1/8" wide, use needle nose pliers to gently squeeze the Electrode to narrow gap. Try the Electrode Check again. If no "clicking" sound is heard:
    - AA Battery may be installed backwards.
    - Electric wires may be loose. Remove the AA Battery and inspect the Ignitor Junction Box found in the Control Box and reconnect any loose wires.

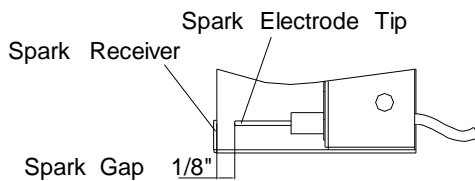

### 14 Install Grease Tray Heat Shield and Cooking Components

- Install the Grease Tray Heat Shield by placing the 4 pins on the Grease Tray Heat Shield into the 4 Holes in the Grill Bowl.
- Place Cooking Grids on bowl ledge.
- Place the Secondary Cooking Rack into the slots on Grill Bowl Side Panels.

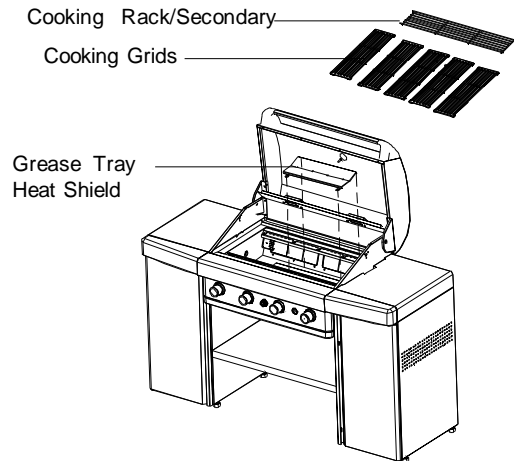

For OB3210BLP/NG Model

### Final Grill Assembly Step

**When you have finished assembling your grill be sure that all screws are tightened for safe operation of your grill.**

**Before each use of the grill, make sure the Grease Tray is fully seated under the Grill Bowl.**

**CAUTION: The Grease Tray should be inspected before each grill use to be sure there is no excessive grease buildup. Clean the Grease Tray frequently to eliminate grease build-up and to prevent grease fires.**

# Assembly Instructions for OB2610ALP/NG & OB3210ALP/NG

**CAUTION :** While it is possible for one person to assemble this grill, obtain assistance from another person when handling some of the larger, heavier pieces.

**CAUTION:** Build your grill island before installing the LP Gas Tank and Partition Panel (Not included in this unit). Refer to the heights listed **on step 6** for constructing your grill island. Make sure a set of doors is installed in your Island so that the Control Box can be accessed. An island unit is not included with the purchase of your Grill Head.

## 1 Set Grill Head into the Island. Install Control Box and Batteries

- Raise the Grill Bowl and put the Control Box into the inside of the Island, then set Grill Bowl into the Island. (the Island not included) (as shown below)
- Open your Island Door, align the Control Box onto the right underside of the Grill Head. (as show below) Install 2 Pan Head Screws 3/16"x3/8" and tighten securely.
- Remove Caps from Control Panel and Control Box. Place 1 AA battery into the slot of the Control Panel and 4 AAA batteries into the slot of the Control Box as shown below.  
**Note:** The positive pole of the AA battery must face towards the cap. For the AAA batteries, 2 batteries must have the positive pole facing towards the cap and 2 batteries must have the negative poles facing away from the caps.
- Position the caps onto the slots, and tighten securely.



Pan Head Screw  
3/16"x3/8"  
Qty. 2  
Part # S182G03061

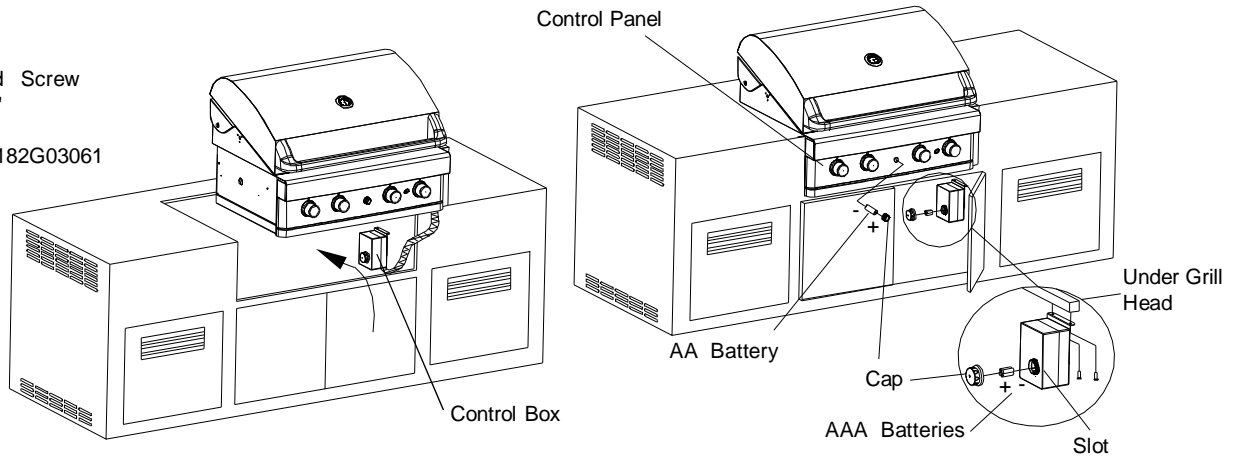

Note: Press the Switch Button to turn on the LED Light Controller before using the grill. Press it again to turn off the LED Light Controller to save battery power when the grill is not in use.

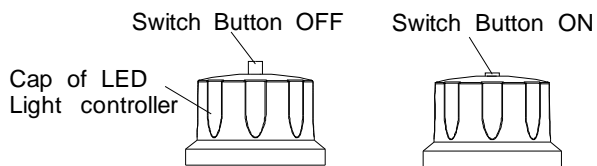

## 2

### Install Transformer. Connect the Transformer to Power Source and Turn on the Grill Lights.

- Install the Transformer Bracket onto the underside of the Right Bowl Panel using 2 Pan Head Screws 3/16"x3/8" and tighten securely (see Fig.1).
- Install Transformer onto the Transformer Bracket by putting the four pre-assembled screws on the Transformer into the four holes on the Transformer Bracket. Press the Transformer downward until it rests in place. (see Fig. 2)
- Install the Transformer-Plug into the Transformer-Socket and tighten securely. (See Fig.4)
- Depending on your island construction, you may need to make one hole on your rear island panel. Make sure the cord doesn't touch the ground then plug the Transformer into the power source. Push the Lamp Switch on the Control Panel to turn on the Grill lamps.

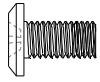

Pan Head Screw  
3/16"x3/8"  
Qty. 2  
Part # S182G03061

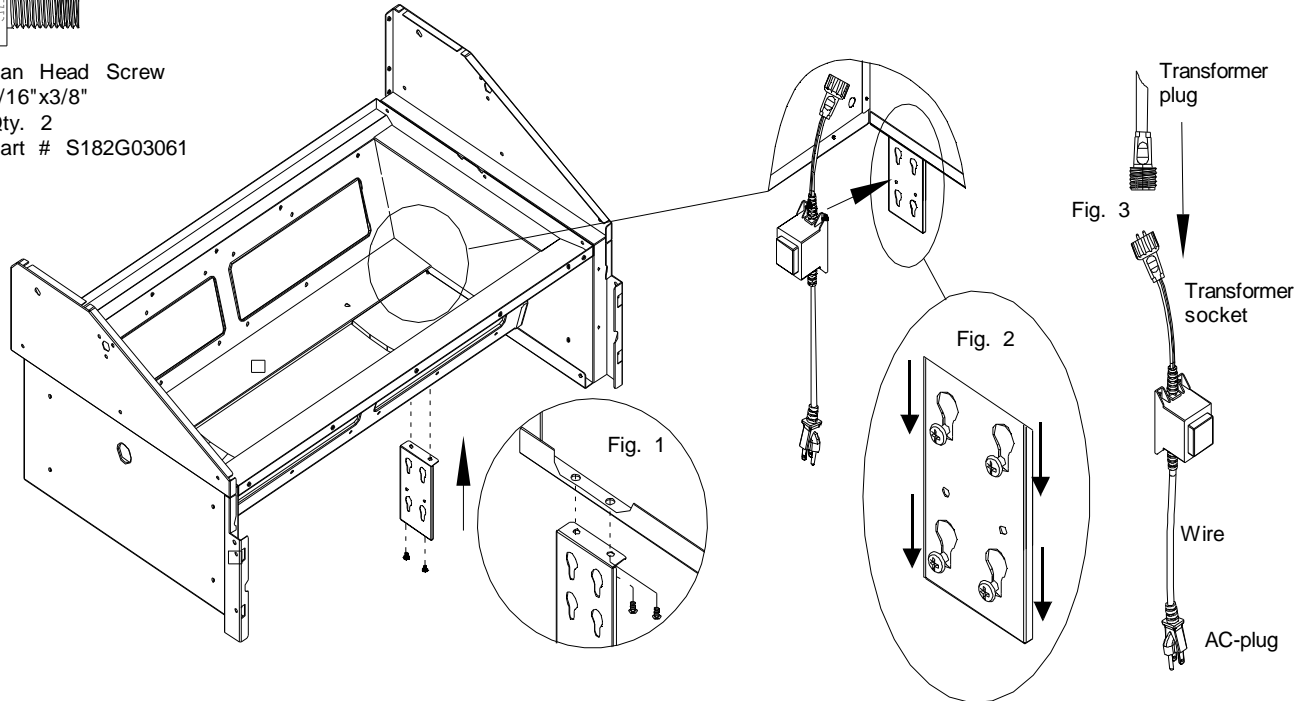

## 3

### Install Regulator

- Install NG Regulator Bracket onto left island side panel using 2 Pan Head Screws 3/16"x3/8". (see Fig. 1)
- Connect the NG Connecting Hose to the Gas manifold. (see Fig. 1)
- Connect the Swivel nut of the 12" Natural Gas Hose onto the vertical fitting of the NG Regulator.
- Install LP Regulator Connector onto left island side panel using 3 Pan Head Screws 3/16"x3/8". (see Fig. 2)
- Connect the LP Regulator Hose to the Gas manifold. (see Fig. 2)



Pan Head Screw  
3/16"x3/8"  
Part # S182G03061  
for NG Model  
Qty. 3  
for LP Model  
Qty. 2

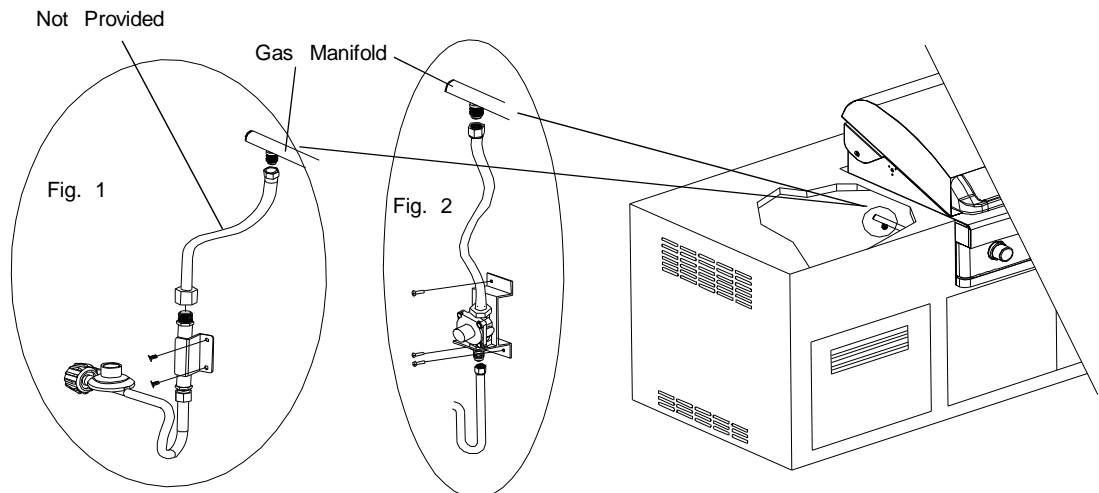

## 4

### Install Tank Tray Set and LP Gas Tank (For LP Model)

- Install the Tank Tray Set onto the Island Bottom Panel. Secure the Tank Tray set by installing 3 Pan Head Screws 3/16"x3/8". (see Fig. 1)
- Place the LP Gas Tank into the Tank Tray. Make sure the Tank Valve faces the right corner of the Island. Tighten the Wing Bolt to secure the LP Gas Tank.
- Install the LP Regulator onto the LP Gas Tank.

**CAUTION:** There shall be a minimum clearance of 2 inches (50.8 mm) between the floor of the LP-gas cylinder enclosure and the ground.

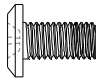

Pan Head Screw  
3/16"x3/8"  
Qty. 3  
Part # S182G03062

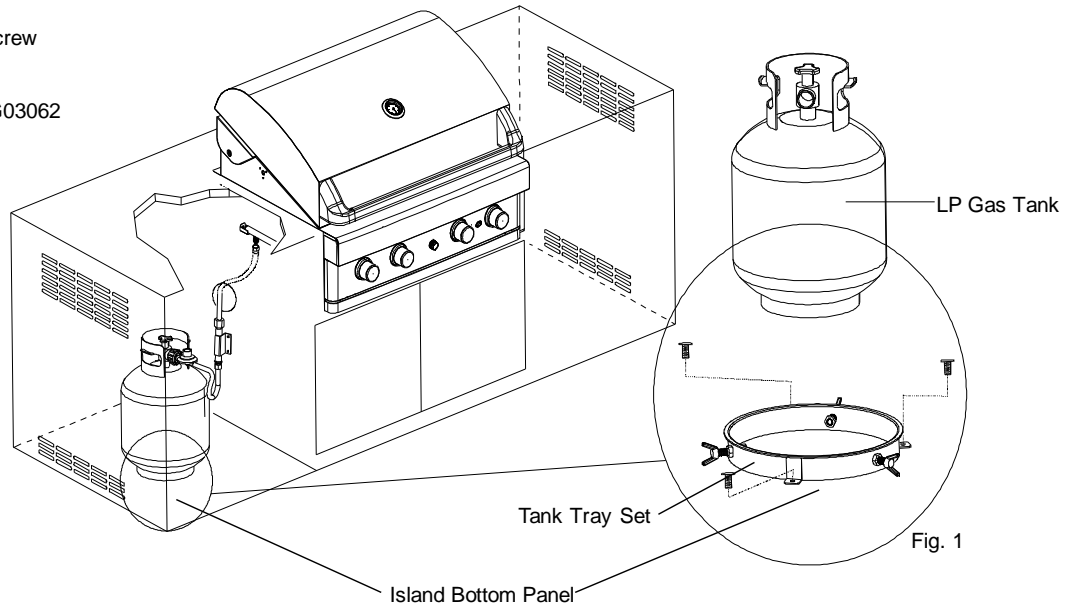

## 5

### Install Partition Panel (for LP Model) (no included this unit)

- Install the Partition Panel onto the left island. Make sure there is 22-23 inches of clearance between the partition panel and the Tank Tray Set.

**Note:** The reason we install partition panel is that the Left Island Bottom only allows the usage of 20 pounds gas tank.

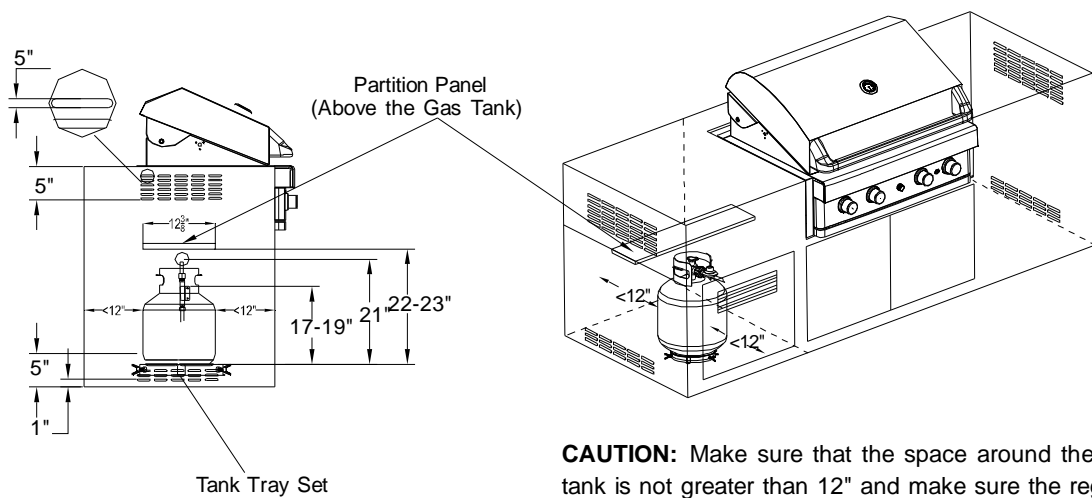

**CAUTION:** Make sure that the space around the gas tank is not greater than 12" and make sure the regulator cannot drop to the ground when disconnected from the cylinder valve.

## 6 Burner Electrode Check. Perform this Electrode Check with the Assistance of Another Person

This test will ensure that the Spark Electrode Tips are properly positioned so your grill lights easily and properly.

- Be sure all Control Knobs are set to "OFF" and open the Grill Lid.
- Have your assistant stand behind you to the right of the grill and look at both the front and rear burner locations of the grill bowl. **Never** put your face inside the Grill Bowl.
- Turn any of the Burner Control Knobs to ⚡ and push in. Have your assistant watch for a blue spark within each Ignition Electrode.
- If no spark is seen, the Spark Gap needs to be adjusted as follows:
  - If the gap between the Spark Electrode Tip and Receiver is more than 1/8" wide, use needle nose pliers to gently squeeze the Electrode to narrow gap. Try the Electrode Check again. If no "clicking" sound is heard:
    - AA Battery may be installed backwards.
    - Electric wires may be loose. Remove the AA Battery and inspect the Ignitor Junction Box found in the Control Box and reconnect any loose wires.

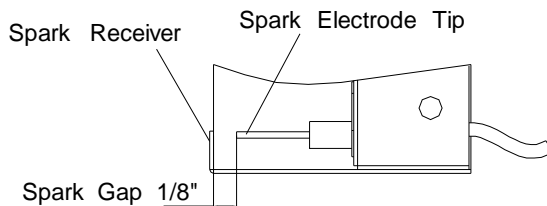

## 7 Install Grease Tray Heat Shield and Cooking Components

- Install the Grease Tray Heat Shield by placing the 4 pins on the Grease Tray Heat Shield into the 4 Holes in the Grill Bowl.
- Place Cooking Grids on bowl ledge.
- Place the Secondary Cooking Rack into the slots on Grill Bowl Side Panels.

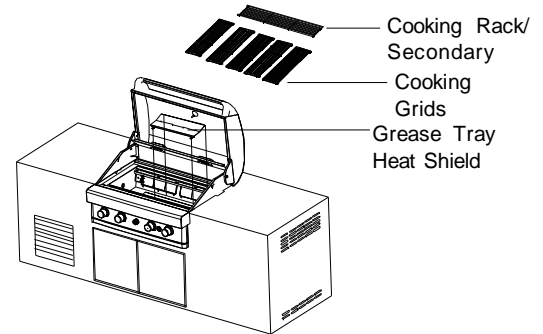

For OB3210ALP/NG Model

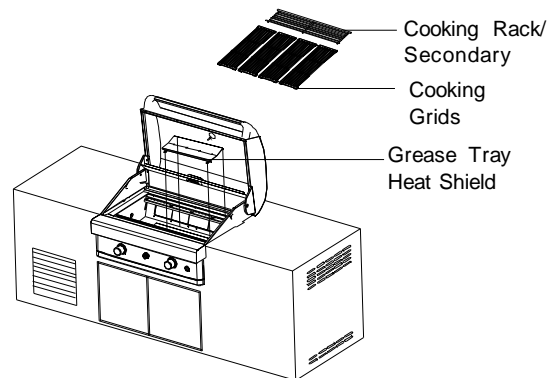

For OB2610ALP/NG Model

## Final Grill Assembly Step

When you have finished assembling your grill, be sure that all screws are tightened for safe operation of your grill.

**CAUTION:** The Grease Tray should be inspected before each grill use to be sure there is no excessive grease buildup. Clean the Tray frequently to eliminate grease build-up and to prevent grease fires.

## LP Gas Tank Installation

### CORRECT LP GAS TANK USE

- LP Gas grill models are designed for use with a standard 20 lb. Liquid Propane Gas (LP Gas) tank, not included with grill. **Never** connect your gas grill to an LP Gas tank that exceeds this capacity. A tank of approximately 12 inches in diameter by 18-1/2 inches high is the maximum size LP Gas tank to use. **You must use an "OPD" gas tank which offers a listed Overfill Prevention Device.** This safety feature prevents the tank from being overfilled which can cause a malfunction of the LP Gas Tank, regulator, and/or grill.
- The LP Gas tank must be constructed and marked in accordance with the Specifications for LP-Gas Cylinders of the U.S. Department of Transportation (D.O.T.) or the National Standard of Canada, CAN/CSA-B339, Cylinders, Spheres and Tubes for Transportation of Dangerous Goods; and Commission, as applicable.
- The LP Gas tank must have a shutoff valve, terminating in an LP Gas supply tank valve outlet, that is compatible with a Type 1 tank connection device. The LP Gas tank must also have a safety relief device that has a direct connection with the vapor space of the tank.
- The tank supply system must be arranged for vapor withdrawal.
- The LP Gas tank must have a collar to protect the tank valve.
- Never** connect an unregulated LP gas tank to your gas grill. The gas regulator assembly supplied with your gas grill is adjusted to have an outlet pressure of 11" water column (W.C.) for connection to an LP gas tank. Only use the regulator and hose assembly supplied with your gas grill. **Replacement regulators and hose assemblies must be those specified by Grand Hall.**
- Have your LP Gas dealer check the release valve after every filling to ensure it remains free of defects.
- Always keep LP Gas tank in upright position.
- Do not subject the LP Gas tank to excessive heat.
- Never store an LP Gas tank indoors. If you store your gas grill in the garage **always** disconnect the LP Gas tank first and store it safely outside.
- LP Gas tanks must be stored outdoors in a well-ventilated area and out of the reach of children.
- Disconnected LP Gas tanks must not be stored in a building, garage or any other enclosed area.
- The regulator and hose assembly can be seen after opening the island doors and must be inspected before each use of the grill. If your regulator and hose are damaged in any way, they must be replaced prior to using the grill again.
- Any attempt to convert the grill from one fuel type to another is extremely hazardous and will void your warranty.
- Never** light your gas grill with the lid closed or before checking to ensure the burners are fully seated over the gas valve orifices.
- Never** allow children to operate your grill. Do not allow children or pets to play near your grill. Always supervise children and pets if they are in the vicinity of the unit.
- Use of alcohol, prescription or non-prescription drugs can impair your ability to properly assemble and safely operate your grill.
- Keep fire extinguisher readily accessible. In the event of an oil/grease fire, do not attempt to extinguish with water. Use type B extinguisher or smother with dirt, sand or baking soda.
- In the event of rain, turn off the burners and gas supply. Wait for the grill to cool, and then place a cover on it.
- Use your grill on a level, stable surface in an area clear of combustible materials.
- Do not leave grill unattended when in use.
- Do not move the appliance when in use.
- Allow the grill to cool before moving or storing.
- Do not use your grill as a heater.
- Never use your gas grill on a balcony, deck, or patio above the ground floor of your home.
- This grill is not intended to be installed in or on recreational vehicles and/or boats.
- The grill is not intended for commercial use.
- Never use charcoal or lighter fluid in this gas grill.



### WARNING



- A. Do not store a spare LP-Gas tank under or near this appliance.
- B. Never fill the tank beyond 80 percent full; and
- C. If the information in "(a)" and "(b)" is not followed exactly, a fire causing death or serious injury may occur.



### WARNING



- Use your grill at least 3 feet away from any wall or surface.
- Use your grill 3 feet away from any combustible objects that can melt or catch fire such as vinyl or wood siding, fences, overhangs (See Diagram Below), or any other sources of ignition; including pilot lights and live electrical appliances.
- Do not use your grill under any overhead combustible construction.
- Never use your gas grill in a garage, porch, shed, breezeway, or any other enclosed area.
- Never use your gas grill on a balcony, deck, or patio above the ground floor of your home.
- In windy conditions, always position the front of the grill to face oncoming wind to reduce heat and smoke blowing in your face, and to prevent potential hazards to yourself and the grill.

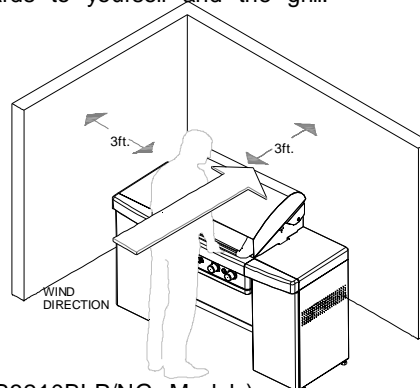

(for OB3210BLP/NG Models)

## USE AND CARE INSTRUCTIONS

### LP Gas Model only: Secure a 20lb LP Gas Tank to Gas Grill (for OB3210BLP)

- Turn your LP Gas Tank Valve clockwise to the closed or OFF position.
- Open the Left Door, place the LP Gas Tank into the Tank Tray Set. Be sure that the bottom of the Tank fully rests in cutout of Tank Tray Set.
- Install the Gas Tank so the Tank Valve faces the right rear corner of cabinet.
- Attach the Regulator with Hose to the gas tank.

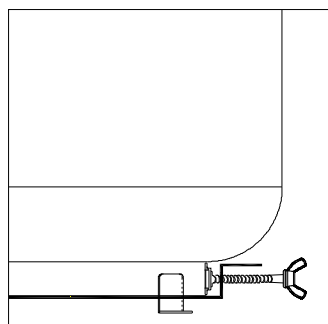
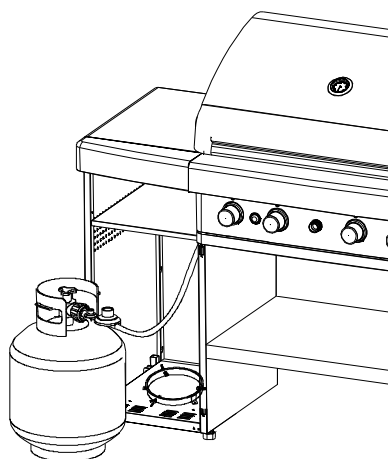

**The Wing Nut holds the Tank Foot in place.**

### Secure a 20lb LP Gas Tank to Gas Grill

Note: You can only use 20lb LP Gas Tank in this Gas Grill.

**NOTE:** When using Liquid Propane (LP), EXTREME CAUTION should be used to provide ample ventilation of vapor from the enclosure. LP gas vapor is heavier than air and SERIOUS INJURY from a DANGEROUS EXPLOSION could occur if LP gas is allowed to accumulate in an enclosure and then ignited. Both the Barbecue enclosure and LP cylinder enclosure require venting that must be provided at the floor level of the enclosure to allow any leaking LP gas vapor to escape (see Fig.1).

**NOTE:** When installing a barbecue equipped for liquid propane (LP) in an built-in, the LP tank must be in a separate enclosure that is completely isolated from the barbecue. It must be cross-ventilated in accordance with local codes. The LP tank MUST NEVER be installed directly under the barbecue.

**NOTE:** The total of the upper ventilation openings must be a minimum of 20 sq. inches. The total of the lower ventilation openings must be a minimum of 10 sq. inches. Upper and lower ventilation openings MUST BE PROVIDED on both sides of built-in construction. The top of the upper ventilation openings must be located within 5" from the top of the built-in. The bottom of the lower ventilation openings must be at least 1" or less from the floor of the built-in. The top of the lower ventilation openings cannot be more than 5" from the floor of the built-in. Every ventilation opening must have a minimum of 1/8" (See Step 6 on page 24). Contact a Grand Hall associate for more details.

**NOTE:** The appliance is only for installation in a built-in enclosure constructed of non-combustible materials.

Fig. 1

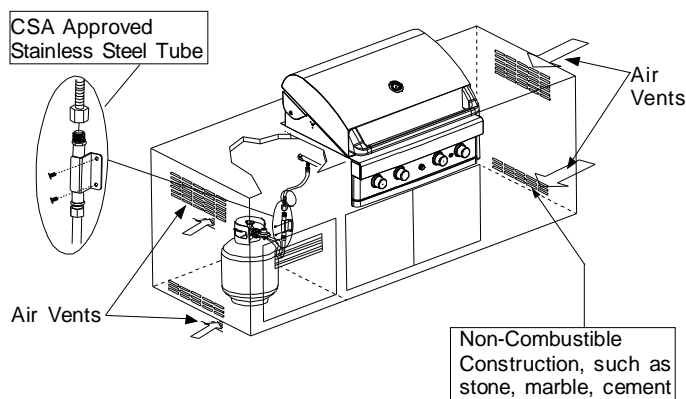

Note: The built-in appliance for use with a remote self-contained LP Gas supply system must use rigid pipe, semi-rigid tubing or a connector complying with the Standard for Connections for Gas Appliance, ANZI Z21.24/CSA 6.10

# USE AND CARE INSTRUCTIONS



## WARNING



Refer to this table when designing the Built-in unit for the OB2610ALP/NG & OB3210ALP/NG. Side\* and Rear\* show the minimum amount of distance the unit must be from combustibles (ex. Vinyl or wood siding, fences and overhangs) or sources of ignition (ex. Pilot lights on water heaters and live electrical appliances). Height\* shows the minimum height the Built-in unit must be starting from the ground up.

Model	Height	Width	Depth	Side*	Rear*	Height*
OB2610A LP/NG	9-1/2"	24-1/2"	19-3/4"	36"	36"	29"
OB3210A LP/NG	9-1/2"	30-1/2"	19-3/4"	36"	36"	29"

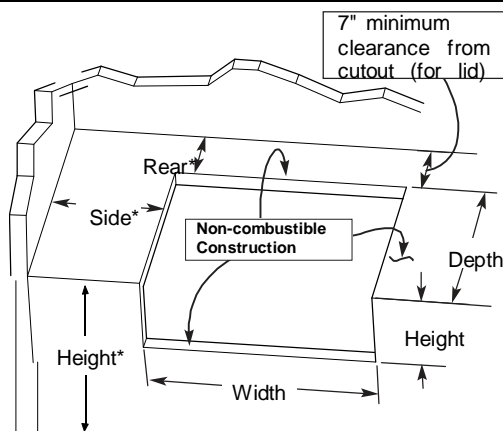

### NOTE about LP Gas Tank Exchange Programs

- Many retailers that sell grills offer you the option of replacing your empty LP Gas tank through an exchange service. Use only those reputable exchange companies that inspect, precision fill, test, and certify their tanks. Exchange your tank only for an OPD safety feature-equipped tank as described in the LP Gas tank section of this Guide.
- Always keep new and exchanged LP Gas tanks in an upright position during use, transit or storage.
- Leak test new and exchanged LP Gas tanks BEFORE connecting one to your grill.

### How to Leak Test your LP Gas Tank

#### For your safety:

- All leak tests must be repeated each time your LP Gas tank is exchanged or refilled.
  - When checking for gas leaks do not smoke.
  - Do not use an open flame to check for gas leaks.
  - Your grill must be leak tested outdoors in a well-ventilated area, away from ignition sources such as gas fired or electrical appliances. During the leak test, keep your grill away from open flames or sparks.
  - Do not use household cleaning agents. Damage to gas assembly components can result.
- Use a clean paintbrush and a 50/50 mild soap and water solution.  
 • Brush soapy solution onto LP Gas tank in the areas indicated by the arrows. See diagram.  
 • If growing bubbles appear do not use or move the LP Gas tank. Call an LP Gas Supplier or your Fire Department.

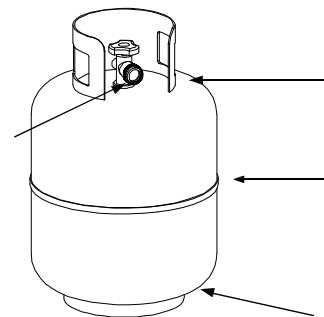

## WARNING



If growing bubbles appear do not use or move the LP Gas tank. Contact an LP Gas Supplier or your fire department!

# USE AND CARE INSTRUCTIONS

## LP Gas Model only:

### Connect Regulator with Hose to your LP Gas Tank

- Turn all Burner Valves to the OFF position.
- Inspect the valve connection port and regulator assembly for damage or debris. Remove any debris. Never use damaged or plugged equipment.
- Connect the regulator assembly to the tank valve and HAND TIGHTEN nut clockwise to a full stop. DO NOT use a wrench to tighten because it could damage the Quick Coupling Nut and result in a gas leak/fire hazard.
- Open the tank valve (counterclockwise) 1/4 to 1/2 of a full turn, and use a soapy water solution to check all connections for leaks before attempting to light your grill. See "**Check all connections for LP Gas Leaks**". If a leak is found, turn the tank valve off and do not use your grill until the leak is repaired.

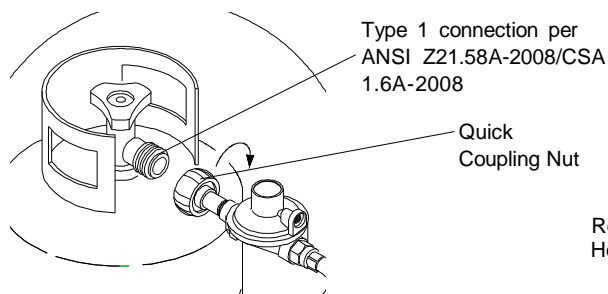

**CAUTION:** When the appliance is not in use the gas must be turned off at the tank. Place dust cap on cylinder valve outlet whenever the cylinder is not in use. Only install the type of dust cap on the cylinder valve outlet that is provided with the cylinder valve. Other types of caps or plugs may result in leakage of propane.

### Check all connections for LP Gas Leaks

Never test for leaks with an open flame. Prior to first use, at the beginning of each season, or every time your LP Gas tank is changed, you must check for gas leaks. Follow these three steps:

- Make a soap solution by mixing one part liquid detergent and one part water.
- Turn the grill Control Knobs to the full OFF position, then turn the gas ON at source.
- Apply the soap solution to all gas connections indicated by the arrows. See diagram. If bubbles appear in the soap solution the connections are not properly sealed. Check each fitting and tighten or repair as necessary.

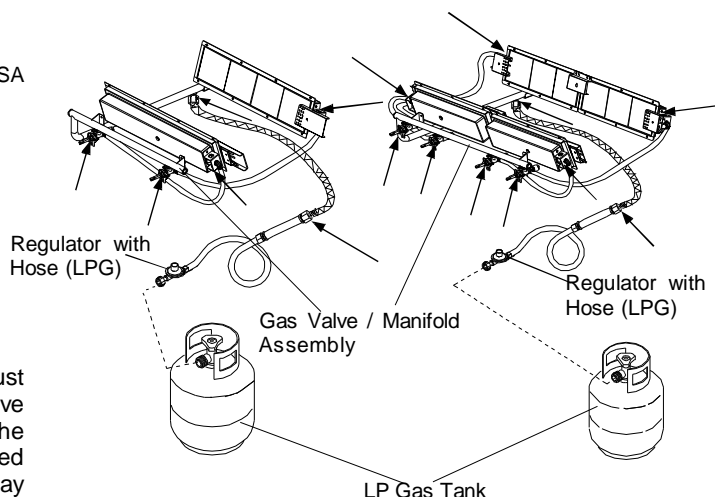

If you have a gas leak that cannot be repaired by tightening, turn off the gas at the source, disconnect fuel line from your grill and call 1-877-934-7455 or your gas supplier for repair assistance.



1. Do not store spare LP cylinder within 10 feet (3m) of this appliance.
2. Do not store or use gasoline or other flammable liquids and vapors within 25 feet (8m) of this appliance.
3. When cooking with oil/grease, do not allow the oil/grease to get hotter 350°F (177°C)
4. Do not leave oil/grease unattended.

### Disconnecting A Liquid Propane Gas (LPG) Tank From Your Grill

- Make sure the Burner Valves and LP Gas tank valve are off. (Turn clockwise to close.)
- Detach the hose and regulator assembly from the LP Gas tank valve by turning the Quick Coupling Nut counterclockwise. Do not use a wrench or any tools when turning the Quick Coupling Nut.



Failure to read and follow the Use and Care Instructions could result in a fire or explosion that could cause serious bodily injury, death or property damage.

# Natural Gas Connection

## Natural Gas Model only: Connecting Natural Gas To Your Grill

- Connect the Swivel nut of the 12' Natural Gas Hose to the horizontal fitting of NG Regulator as shown in **Fig.1**. Connect the other hose end (male plug) to the gas supply line from your home. Read and follow the "Natural Gas Safety Instructions" below.

## Natural Gas Safety Instructions

- Your natural gas grill is designed for use with natural gas (NG) only. The gas pressure Regulator supplied with this appliance **must** be installed and used on your grill. The unit and Regulator are set to operate with an outlet pressure of 4" W.C.
- Install a Shutoff Valve at the gas supply source outdoors at a point after the gas pipe exits the outside wall and before the quick-disconnect hose. Or install it at the point before the gas line piping enters the ground. See **Fig. 2**.
- Pipe sealing compound or pipe thread tape resistant to the action of natural gas must be used on all male pipe thread connections.
- Disconnect your gas grill from fuel source when the gas supply is being tested at high pressures. This gas grill and its individual shutoff valve must be disconnected from the gas supply pipe system during any pressure testing of that system at pressure in excess of 1/2 psi (3.5kpa).
- Turn off your gas grill when the gas supply is being tested at low pressures. The grill must be isolated from the gas supply pipe system by closing its individual manual shutoff valve during any pressure testing of the gas supply pipe system at pressures equal to or less than 1/2 psi (3.5kpa).
- The Quick Disconnect connects to a 3/8 inch NPT thread from the gas source. The Quick Disconnect fitting is a hand operated device that automatically shuts off the flow of gas from the source when it is disconnected.
- The Quick Disconnect fitting can be installed horizontally or pinpointing downward. **DO NOT** install the fitting with the opening pointing upward because the fitting could collect water and debris.
- The Dust Covers (plastic plugs) provided with the Quick Disconnect Hose help keep the open ends clean while disconnected.

**WARNING:** Do not route the 12 Foot Quick Disconnect Hose under a deck. The hose must be visible and inspected prior to each grill use.

## Gas Line Piping:

- If the length of line required does not exceed 50 feet, use a 5/8" O.D. tube. One size larger should be used for lengths greater than 50 feet.
- Gas piping must be copper tubing, type K or L; polyethylene plastic tube, with a minimum wall thickness of 0.62 inch; or standard weight (schedule 40) steel or wrought iron pipe.
- Copper tubing must be tin-lined if the gas contains more than 0.3 grams of hydrogen sulfide per 100 cubic feet of gas.
- Plastic tubing is suitable only for outdoor, underground use.
- Gas piping in contact with earth, or any other material which may corrode the piping, must be protected against corrosion in an approved manner.
- Underground piping must have a minimum of 18" cover.

**Fig.1**

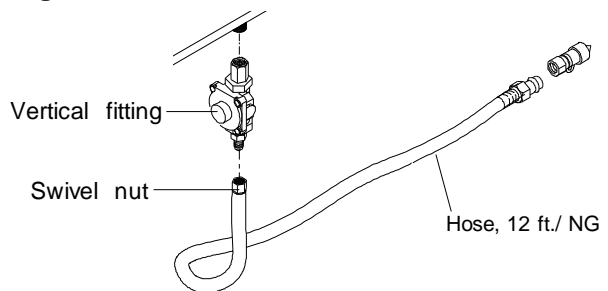

## Check all connections for Natural Gas Leaks

**Never** test for leaks with an open flame. Prior to first use and at the beginning of each season, you must check for gas leaks. Follow these three steps:

- Make a soap solution by mixing one part liquid detergent and one part water.
- Turn the grill Control Knobs to their full OFF positions. Next, turn the gas ON at the source.
- Apply the soap solution to all gas connections indicated by the arrows. See **Fig.3**. If bubbles appear in the soap solution the connections are not properly sealed. Check each fitting and tighten or repair as necessary.

**Fig.3**

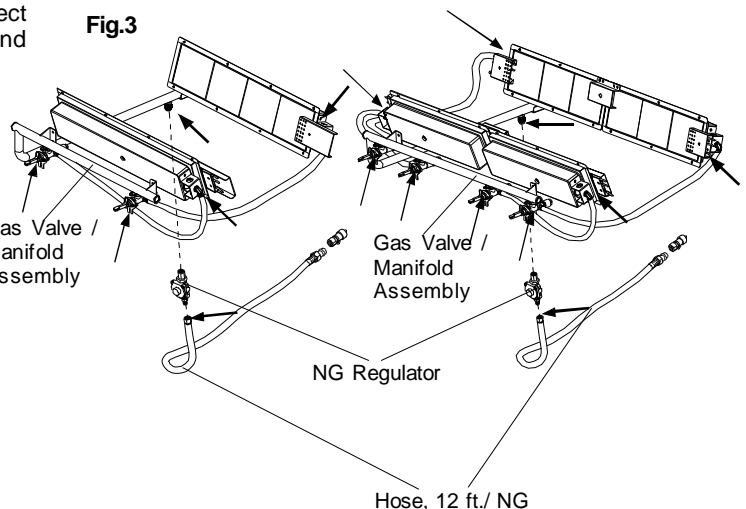

**Fig.2**

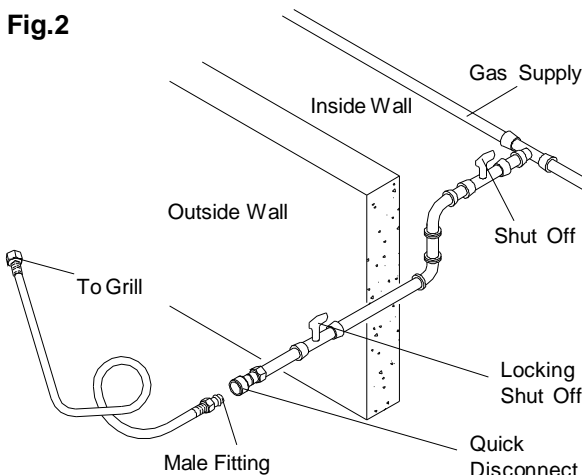

# USE AND CARE INSTRUCTIONS

## Grill Lighting Instructions

1. Read all instructions before lighting.
2. Before each use, check all hoses for cracks, nicks, cuts, burns, or abrasions. If a hose is damaged in any way, do not use your grill before replacing the hose with an authorized part from the Parts List. Also make sure all gas supply connections are securely tightened.
3. Familiarize yourself with the Safety and Use and Care instructions in this Guide. Do not smoke while lighting grill or checking gas supply connections.
4. Be sure the LP Gas tank is filled, and lock Casters to prevent movement during grill operation.
5. Open Lid during lighting.

### WARNING

Failure to replace a faulty hose, secure gas supply connections or to open the Lid before proceeding to the Lighting Procedures could result in a fire or explosion that could cause serious bodily injury, death, or property damage.

6. Set Control Knobs to OFF and open the LP Gas tank valve **SLOWLY 1/4 of a full turn**. For Natural Gas open the Shut Off Valve at the source.

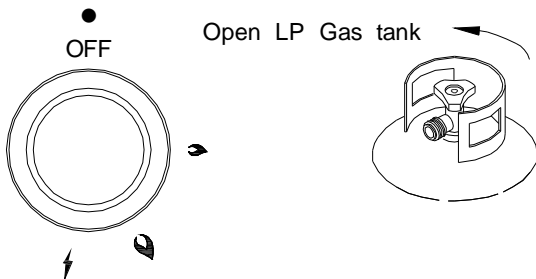

7. Push and turn the control knob to and hold it in 3-5 seconds to ignite the Burner. Once the burner is ignited continue to push down the knob and rotate to . Continue to depress the knob in until the burner indicator light turns on then release it.

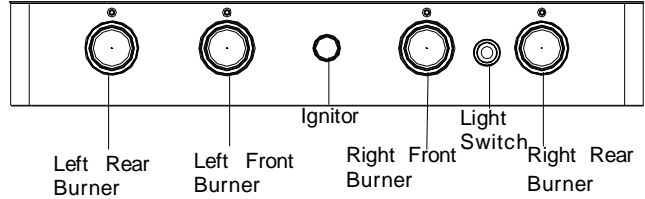
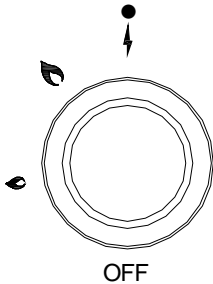

For OB3210ALP/NG & OB3210BLP/NG Models

8. If ignition does not occur in 5 seconds, turn gas off at source and turn Control Knobs OFF. Wait at least 5 minutes for gas to clear, then retry. If your grill still fails to light turn the burner Control Knob(s) and gas source OFF and conduct a leak test of ALL gas connections and gas sources as explained in the Use and Care section of this guide. If no leaks are detected, wait 5 minutes for any gas to clear and repeat the lighting procedure.
9. If the burner indicator light does not work, check the batteries.
10. After one Burner is lit, turn the tank valve SLOWLY one more 1/4 of a turn.
11. To light more burners, turn each burner knob to , then back to .

## Manually Lighting Your Grill By Paper Match

To light your gas grill by match, insert a match into the Lighting Stick and follow steps 1 through 6 of the Grill Lighting Instructions. Then, light the match and place Lighting Stick through the Cooking Grid on the grill as shown below. Turn the nearest Control Knob to the setting to release gas. The Burner should light immediately.

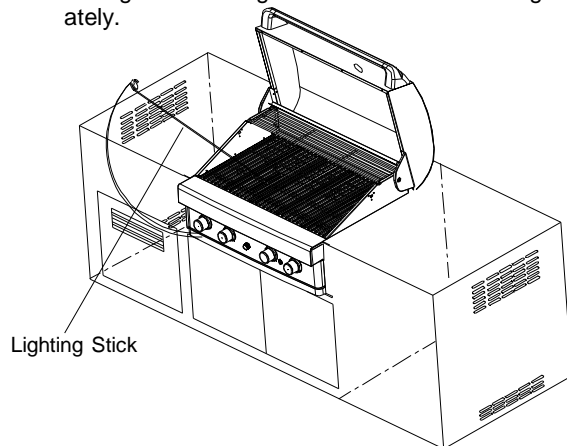

Note: Built-in is shown for illustrative purposes only. Built-in is not included with grill unit.

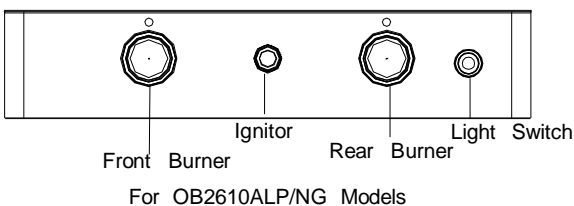

For OB2610ALP/NG Models

### NOTE

Replace the batteries when low battery as noted below:

1. If LED burner indicator light does not work when burner is lit.
2. If any of the LED indicator(s) is lit when its related burner is in "OFF" position.

# USE AND CARE INSTRUCTIONS

## Troubleshooting

### If the grill fails to light :

1. Turn gas off at source and turn Control Knobs to OFF. Wait at least 5 minutes for gas to clear, then retry.
2. If your grill still fails to light, check gas supply and connections.
3. Repeat lighting procedure. If your grill still fails to operate, turn the gas off at source, turn the Control Knobs to OFF, then check the following:
  - Obstruction in gas line  
**Correction:** Remove regulator hose from grill. Do not smoke! Open gas supply for one second to clear any obstruction from fuel line. Close off gas supply at source and reconnect fuel line to grill.
  - Disconnected Electric Wires  
**Correction:** Inspect the Electric Ignitor (see Parts List) found in the Control Box. Connect loose Electric wires to Junction Box and try to light the grill.
  - Weak AA or AAA Battery  
**Correction:** Remove the Ignitor Cap and replace the battery.
  - If the grill still does not light you may need to purge air from the gas line or reset the regulator excess gas flow device. **Note:** This procedure should be done every time a new LP Gas tank is connected to your grill.

**WARNING**

**Never** lean over the grill cooking area while lighting your gas grill. Keep your face and body a safe distance (at least 18 inches) from the front of grill when lighting your grill by match.

**WARNING**

If ignition does not occur in 5 seconds, turn the Control Knob(s) and gas source OFF and conduct a leak test as explained in the Use and Care section of this guide. If no leaks are detected, wait 5 minutes for any gas to clear and repeat the lighting procedure.

### To purge air from your gas line and/or reset the regulator excess gas flow device:

- Turn Control Knobs to the OFF position.
- Turn off the gas at the tank valve.
- Disconnect regulator from LP Gas tank. For Natural Gas disconnect regulator from 12 ft. Natural Gas Hose.
- Let unit stand 5 minutes to allow air to purge from gas line.
- Reconnect regulator to the LP Gas tank. For Natural Gas reconnect regulator to 12 ft. Natural Gas Hose.
- Turn tank valve on SLOWLY 1/4 of a turn. For Natural Gas open Shut Off valve.
- Open the Grill Lid.
- Push and turn the Control Knob to ⚡ and hold it in 3-5 seconds to ignite the burner.

**WARNING**

Should a FLASHBACK fire occur in or around the Burners, follow the instructions below. Failure to comply with these instructions could result in a fire or explosion that could cause serious bodily injury, death, or property damage.

- Y Shut off gas supply to the gas grill.
- Y Turn the Control Knobs to OFF position.
- Y Open the Grill Lid.
- Y Put out any flame with a Class B fire extinguisher.

**GRILL INFORMATION CENTER**  
 Call 1-877-934-7455 Monday - Friday 8:00am-4:30pm CST

## USE AND CARE INSTRUCTIONS

### CORRECT TRANSFORMER AND LIGHT USE

Read all instructions before initial use.

**IMPORTANT:** When using transformer appliances, basic safety precautions should always be used.

The Transformer is set for 120V, 60Hz AC current input, 12VAC, 25W output. The Light is set for 12V, 10W.

Do not let children operate or play nearby your grill or Transformer. Always supervise children and pets if they are in the vicinity of the unit.

#### Connecting Transformer

Always attach the assembled Transformer to your grill first and then plug the Cord into a properly grounded outlet, then turn on the Lights.

#### Operating Transformer and Light

Do not operate the Transformer if the cord or plug becomes damaged, or if the Transformer or Light malfunctions or have been damaged in any manner.

Do not operate the Transformer if the cord or plug has been damaged in any manner. Do not use the Transformer and Light if cannot be operated safely.

Do not immerse Electrical Cord or Plug in water or expose to rain, as this may result in an electrical shock.

#### Disconnect Transformer

Be careful as all surfaces will be hot, both grill, Transformer and the Light. Turn off the Lights and unplug the Transformer from electrical outlet when not in use and before cleaning.

### ELECTRICAL EQUIPMENT USE

1. To protect against electric shock, do not immerse cord or plugs in water or other liquid.
2. Allow Rotisserie and Grill to cool before putting on or taking off parts.
3. Do not operate any outdoor cooking gas appliance with a damaged cord, plug, or after the appliance malfunctions or has been damaged in any manner. Call 1-877-934-7455 for repair.
4. Do not let the cord hang over the edge of a table or touch hot surfaces.
5. Do not use an outdoor cooking gas appliance for purposes other than intended.
6. When connecting, first connect plug to the outdoor cooking gas appliance then plug appliance into the outlet.
7. Use only a Ground Fault Interrupter (GFI) protected circuit with this outdoor cooking gas appliance.
8. Never remove the grounding plug or use with an adapter of 2 prongs.
9. Use only extension cords with a 3 prong grounding plug, rated for the power of the equipment, and approved for outdoor use with a W-A marking.



### WARNING



To protect against electrical shock, do not immerse electrical cord, plugs or motor in water or expose to rain. Protect electrical elements from burners, hot grill surfaces and grease.



### CAUTION



To protect against shock hazard risk, connect only to properly Grounded Outlet.



### WARNING



California Proposition 65  
The electrical supply cord and plug of the rotisserie contain chemicals, including lead, known to the State of California to cause cancer, and birth defects or other reproductive harm. Wash hands after handling.



### CAUTION



When using electrical appliances, basic safety precautions should always be used.

## CLEANING AND MAINTENANCE

Proper care and maintenance will keep your grill in top operating condition and prolong its life. Follow these cleaning procedures on a timely basis and your grill will stay clean and operate with minimum effort.

**CAUTION:** Be sure your grill is OFF and cool before cleaning.

### Cleaning The Cooking Grids

- Before initial use and periodically thereafter, wash your Cooking Grids in a mild soap and warm water solution. You can use a wash cloth or vegetable brush to clean your cooking grids.

### Cleaning The Grease Tray

- To reduce the chance of fire, the Grease Tray should be visually inspected before each grill use. Remove any grease and wash Grease Tray with a mild soap and warm water solution.

### Cleaning the Inside of the Grill Lid

- Grease can build up on the inside of the Grill lid over time. This grease can drip onto your deck or patio when the lid is opened. Visually inspect the inside of the Grill Lid before each grill use. Remove any grease and wash with a mild soap and warm water solution.

### Routine Cleaning of The Grill Interior

- Burning-off excess food after every cookout will keep it ready for instant use. However, at least every 3 months you must give the entire grill a thorough cleaning to minimize your risk of grease fire and keep the grill in top shape. Follow these steps:
  1. Turn all Burner Knobs to the full OFF position.
  2. Turn the LP gas tank valve to the full OFF position.
  3. Disconnect the regulator from the gas tank. Inspect the hose with regulator assembly for cracking, cuts or any other damage, and replace as necessary. Refer to the Parts List in this Operator's Manual.
  4. Remove and clean the Cooking Grids and Secondary Cooking Rack.
  5. Brush the inside and bottom of the grill with a fiber pad or nylon brush and wash with a mild soap and warm water solution. Rinse thoroughly and let dry.
  6. Check each Spark Electrode, adjusting as needed. The space between the Spark Electrode Tip and Spark Receiver should be approximately 1/8" (3.2mm).
  7. Replace the Cooking Grids and Secondary Cooking Rack.
  8. Reconnect the gas source and observe the Burner flame for correct operation.

### Cleaning Exterior painted Surfaces:

Before initial use, and periodically thereafter, we suggest you wash your grill using a mild soap and warm water solution. You can use a wash cloth or sponge for this process. Do not use a stiff wire or brass brush. These will scratch stainless steel and chip painted surfaces (varies by model) during the cleaning process.



### Cleaning Exterior Stainless Steel Surfaces:

- Routine care and maintenance is required to preserve the appearance and corrosion resistance of stainless steel. The fact is stainless steel can corrode, rust and discolor under certain conditions. Rust is caused when regular steel particles in the atmosphere become attached to the stainless steel surface. Steel particles can also become attached to your grill if you use steel wool or stiff wire brushes to clean the grill instead of non-abrasive cloth, sponge or nylon cleaning tools. In coastal areas rust pits can develop on stainless surfaces that cannot be fully removed. Bleach and other chlorine based solutions used for household and pool cleaning can also cause corrosion to stainless steel. Weathering, extreme heat, smoke from cooking and machine oils used in the manufacturing process of stainless steel can cause stainless steel to turn tan in color. Although there are many factors which can affect the surface appearance of stainless steel, they do not affect the integrity of the steel or the performance of the grill.

- To help maintain the finish of stainless steel follow these cleaning tips for the best results:

1. After every use (after your grill has cooled down), wipe stainless surfaces with a soft, soapy cloth or sponge then rinse with water. Be sure to remove all food particles, sauces or marinades from stainless steel because these can be highly acidic and damaging to stainless surfaces.
2. Never use abrasive cleaners, scrubbers or stiff wire brushes of any type on your grill.
3. Use a heat resistant Stainless Steel Cleaner and rub or wipe in the direction of the stainless steel grain or polish lines. Do not polish against the grain.

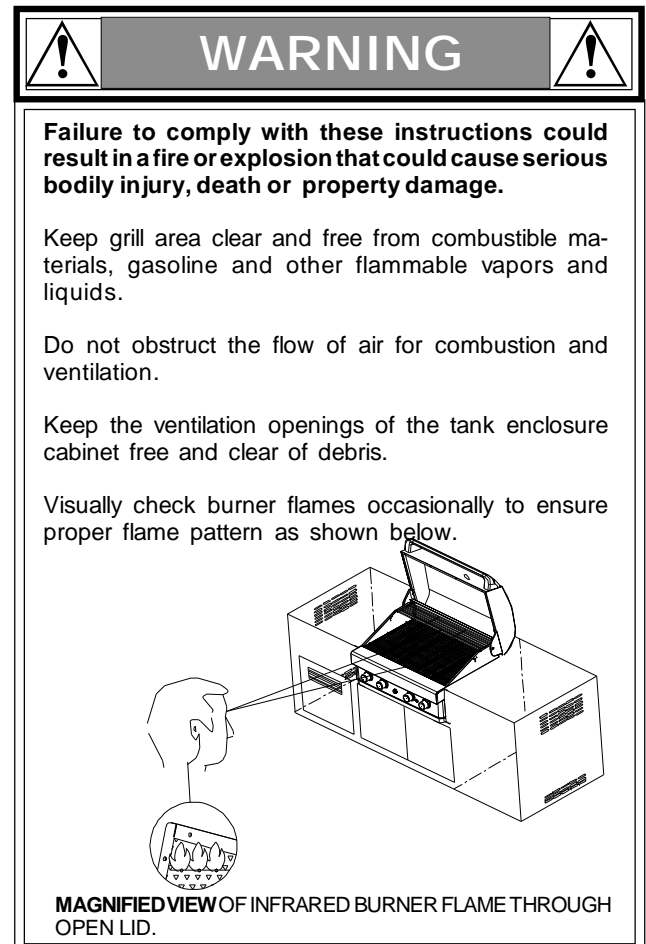

# Infrared Grill Cooking Instructions

## Burn-Off

- Before cooking on your gas grill for the first time, you should "burn off" the grill to eliminate any odor or foreign matter. Ignite the burners, lower the Lid, and operate grill on 🔥 setting for 3 to 5 minutes.

**CAUTION:** Infrared cooking times will be much shorter than traditional grilling so never operate this appliance unattended.

## Preheating

- To preheat, light your grill on 🔥, lower the Lid and follow this timetable.
- ℹ For searing and high temperature cooking, preheat grill 3 to 5 minutes.
- ℹ For low temperature cooking, preheat grill 3 minutes.
- ℹ To slow cook, preheating is not necessary.

## Control Knob Settings

- High setting:** The 🔥 Control Knob setting should only be used to pre-heat your grill the first 3-5 minutes, for searing foods and for burning food residue off the grill for 3-5 minutes after cooking is complete.

**CAUTION:** Infrared burners burn much hotter than burners on traditional grills. Never operate this appliance unattended.

- Low setting 🔥:** Most recipes specify the low setting for baking, roasting, rotisserie cooking and grilling delicate foods such as fish, vegetables and bread.

## An Important Note About Infrared Heat Settings

- The suggested heat settings and cooking times shown in the following pages are approximate. Unlike the controlled environment inside your kitchen, variables including outside temperatures, direction and conditions of wind, as well as grill location will affect your grill's heat distribution. Because these conditions vary, and no two backyards are alike, we offer these tips as general guidelines for your reference. We recommend you monitor your grill closely and rotate foods often to prevent overcooking and ensure the most delicious results every time.
- ℹ The heat from the front and rear infrared burners overlap in the mid section of each cooking grid. This area offers the most intense heat for quickly locking in the natural juices and flavor of poultry and meats.
- ℹ The Secondary Cooking Rack offers less intense heat for preparing breads and firm vegetables like potatoes and corn.
- ℹ Infrared heat sears the food surface and cooks from the inside out. Infrared heat does not cook through aluminum foil and reflective pans. For roasting and baking you'll find a cast-iron pan works beautifully as it absorbs and conducts the infrared heat very well.

## Direct Cooking

- The direct cooking method can be used with the food placed on the mid section of each cooking grid where the infrared heat is most intense. **Direct Cooking requires the Grill Lid to be open.** This method is ideal for searing and grilling as well as deep frying in a cast-iron pan or stir-frying in a steel wok.

## Indirect Cooking

- To cook **indirectly**, the food should be placed on the left or right side of your grill (or Secondary Rack) with the Burners lit on the opposite side. Rotate the food as needed to ensure even browning. This is the slow cooking method. A faster indirect method is to place your food in an optional cast-iron cooking pan and place it in the center of the grill with all burners on LOW. Be sure to add liquid if using a pan to keep food moist. If higher heat is desired, turn Left Front (LF) and Right Rear (RR) burners on HIGH with Left Rear (LR) and Right Front (RF) burners on LOW to create a crossray cooking pattern. Either way, **indirect cooking must be done with the Lid down.**

## Prepare Cooking Grids for Grilling

- Greasing the cooking surface will help keep foods from sticking during the cookout, produces beautiful sear marks and reduces the amount of cleanup required. Use a brush to apply a thin layer of cooking oil or vegetable shortening onto each Cooking Grid before each cookout. We do not suggest spray type oils unless they are specified for high-temperature cooking.

## To Reduce Flare-Ups and Smoke

- Fat and juice dripping from grilled food can cause flare-ups and smoke. To minimize this, cook your food in the mid section of each cooking grid so drippings fall through the center of the grill into the Grease Tray below.

 **WARNING** 

ℹ Failure to comply with these instructions could result in a fire or explosion that could cause serious bodily injury, death or property damage.

ℹ Never cover the cooking grids, bottom of grill bowl or Grease/Water Tray with charcoal, aluminum foil, and or any substance that can absorb grease.

ℹ **Before each use of your grill:** Pull out the Grease Tray and remove all grease and food debris to prevent grease fire hazard.

ℹ **Use your grill at least 3 feet away from any wall or surface.** Use your grill at least **3 feet away** from combustible objects that can melt or catch fire (such as vinyl or wood siding, fences and overhangs) or sources of ignition including pilot lights on water heaters and live electrical appliances.

ℹ **Never** use your gas grill on a balcony, deck, or patio above the ground floor of your home.

ℹ **Never** use your gas grill in a garage, porch, shed, breezeway or any other enclosed area.

ℹ **Your grill will get very hot.** Always wear a flame retardant BBQ Mitt when cooking on your grill and handling the Grease Tray. Never lean over cooking areas while using grill. Do not touch cooking surfaces, Lid, grill housing or other parts while grill is in operation, or until the grill has cooled down after use.

## Guide to Infrared Grilling using the Direct Cooking Method

### Grilling Steak and Ribs

Turn the grill Burners on , close the Lid and preheat your grill 3 to 5 minutes. Open Lid and place food on the mid section of a Cooking Grid. Sear 2-3 minutes on each side then adjust the Infrared Burners to LOW and continue cooking until desired doneness. You can also move the seared meat to the Secondary Cooking Rack to finish cooking. This method allows you to sear and prepare larger amounts of meat and keep cooked food warm. Grilling times will vary according to meat thickness.

### Grilling Hamburgers, Brats and Sausages

Turn the grill Burners on , close Lid and preheat your grill 3 to 5 minutes. Open Lid and place food on the mid section of a Cooking Grid. Sear 2-3 minutes on each side then adjust the Infrared Burners to LOW and continue cooking until desired doneness. Grilling times will vary according to meat thickness.

### Grilling Poultry

Turn the grill Burners on , close Lid and preheat your grill 2 to 3 minutes. Open Lid and place food on the mid section of a Cooking Grid. Sear 2-3 minutes on each side then adjust the Infrared Burners to LOW and continue cooking until desired doneness.

To minimize flare-ups, use skinless poultry or use the indirect method. Place the poultry on one side of the grill with the opposing Burners on LOW heat, and lower the grill Lid.

### Grilling Pork

Turn the grill Burners on , close Lid and preheat your grill 3 to 5 minutes. Open Lid and place food on the mid section of a Cooking Grid. Sear 2-3 minutes on each side then adjust the Infrared Burners to LOW and continue cooking until desired doneness. Grilling times will vary according to meat thickness.

### Whole Fish and Whole Fillets

Turn the grill Burners on , close Lid and preheat your grill 3 to 5 minutes. Open Lid and place food (skin down) on the mid section of a Cooking Grid. Sear 2 minutes on each side then adjust the Infrared Burners to LOW and continue cooking until fish is opaque but still moist.

### Vegetables and Fruit

Prepare your fruit or vegetables and brush with butter or basting sauce if desired. In some instances, you may want to grill vegetables and fruit **directly** over the heat, using the supplied Cooking Grids. Foods that work best with direct heat are relatively soft and require a short cooking time: mushrooms, zucchini, tomatoes and skewered fruit such as apricots, peaches, pineapple, strawberries and kiwis. Remember the **Grill Lid must remain up when cooking directly**.

To cook **indirectly**, the food should be placed on the left or right side of your grill (or Secondary Rack) with the Burners lit on the opposite side. Either way, **indirect cooking must be done with the Lid down**.

### Cut of Meat

T-bone steak  
Sirloin steak  
Beef spare ribs  
Porterhouse Steak  
New York strip steak

### Approx. Total Cooking Times

**Rare:** 4-6 minutes  
**Medium:** 6-8 minutes  
**Well done:** 8-10 minutes

Hamburgers  
Brats  
Sausages

**Rare:** 3-4 minutes  
**Medium:** 5-6 minutes  
**Well done:** 6-8 minutes

Chicken breast  
(cook with bone down)  
Chicken wings  
Drumsticks

**Direct method:**  
approximately 6-8 minutes

**Indirect method:**  
up to 30 minutes

Whole bird  
(cook with breast up)

**Indirect method:**  
approximately 1 hour

Chops  
Loins  
Cutlets

**Medium:** 10-12 minutes  
**Well done:** 12-14 minutes

Whole fish  
Whole fish fillets

Approx. 8 - 18 minutes or  
until fish is opaque

For very firm vegetables—particularly potatoes and yams, we recommend that you partially boil until almost cooked, before placing them on the grill.

**CAUTION:** Infrared cooking times will be much shorter than traditional grilling so never operate this appliance unattended.

**NOTE:** Do not use aluminum foil to wrap vegetables and fruit. Infrared heat does not cook through aluminum foil and reflective pans.

# Guide to Roasting & Baking using the Indirect Cooking Method

## An Important Note About Infrared Heat Settings

The suggested heat settings and cooking times shown are approximate. Unlike the controlled environment inside your kitchen, variables including outside temperatures, direction and conditions of wind, as well as grill location will affect your grill's heat distribution. Because these conditions vary, and no two backyards are alike, we offer these tips as general guidelines for your reference. We recommend you monitor your grill closely and rotate foods often to prevent overcooking and ensure the most delicious results every time.

## Preparing to Roast

Roasting uses the **indirect cooking** method. Therefore, the food should be placed on the left or right side of your grill with the Burners lit on the opposite side. You can also use an optional cast-iron pan underneath food allowing you to collect juices for making gravies. Remember, indirect cooking requires the Lid of your grill to be down.

Preheating your grill is not required for slow cooking methods such as roasting. If you do choose to preheat your grill before roasting, turn the Burners on HIGH and close Lid for approximately 2 minutes.

Type of Food	How Cooked	Approximate Cooking Times
Beef	Rare	14 minutes per pound
	Medium	18 minutes per pound
	Well done	20 minutes per pound
Lamb	Medium	14 minutes per pound
	Well done	18 minutes per pound
Veal		22 minutes per pound
Pork		23-26 minutes per pound
Chicken		17-20 minutes per pound
Duck		20 minutes per pound
Fish		8 minutes per pound
Turkey, under 16 pounds		17-20 per pound + 20 minutes
Turkey, over 16 pounds		14-18 per pound + 10 minutes

## BAKING TECHNIQUES

### Preparing to Bake

To bake in your new grill you'll need a baking dish or cast-iron cooking pan, and a pair of flame retardant BBQ Mitts. If the cooking pan is cast-iron be sure to season the pan before use. Preheat your grill 3 minutes, then lower heat as needed. Baking uses the **indirect cooking** method. To cook **indirectly**, the food should be placed on the left or right side of your grill with the Burners lit on the opposite side. This is the slow cooking method. A faster indirect method is to place your food in an optional cast-iron cooking pan and place it in the center of the grill with all burners on LOW. If higher heat is desired, turn Left Front (LF) and Right Rear (RR) burners on HIGH with Left Rear (LR) and Right Front (RF) burners on LOW to create a crossray cooking pattern. Either way, **indirect cooking must be done with the Lid down**.

### Tips for Baking

Prepare your favorite recipe as you would in the kitchen. You will need to stir the food several times as it bakes, and add additional liquid as required. Watch the temperature, and adjust to cook according to your recipe directions.

### Oven Temperature

Slow	300° - 340° F
Moderate	355° - 390° F
High	410° - 480° F

## Food preparation

Trim meat of excess fat. Truss meat and poultry with cooking string to retain shape if desired. Bacon strips can be used to cover the outside surface of lean meat and poultry to help prevent it from drying out. If using an optional cast-iron pan for cooking, you should also add liquid to prevent burning the bottom of your food.

## Tips for roasting

Except when roasting with water in a roasting pan, the juices that collect in the pan can be used as the base for a tasty sauce or gravy. Place a cooking pan directly over the cooking grids, add extra butter if needed, then add several spoonfuls of flour to thicken sauce. Finally, add sufficient chicken or beef stock to obtain the desired consistency.

Once the meat is cooked, remove it from your grill and cover with a piece of foil. Allow it to stand for 10-15 minutes which allows the juices to settle. This will make carving easier and ensure a tender, juicy roast.

Safe Minimum Internal Temperatures	
Fish	145°F/63°C
Pork	160°F/71°C
Egg Dishes	160°F/71°C
Steaks and Roasts of Beef, Veal or Lamb	145°F/63°C
Ground Beef, Veal or Lamb	160°F/71°C
Whole Poultry (Turkey, Chicken, Duck, etc.)	165°F/74°C
Pieces of Poultry (Chicken Breast, etc.)	165°F/74°C

### Recommended Grill Setting

Left or right 2 burners on LOW
All 4 burners on LOW
LF + RR burners on HIGH and LR + RF burners on LOW

## Guide to Stir-Frying and Deep-Frying

### STIR-FRYING TECHNIQUES

This method of cooking is popular around the world and can be easily accomplished outdoors on your gas grill. It's a quick and healthy way of preparing a complete meal using meat, poultry or seafood in infinite combinations with other interesting ingredients like vegetables, rice or noodles.

#### Preparing to Stir-fry

Although it is possible to stir fry in other dishes, a wok is your best tool. Its high sides enable the cook to stir food without spillage. Its construction allows you to cook quickly at high temperatures, with instant control of heat which is essential for successful stir frying.

#### Food preparation

Slice meat and poultry into long thin strips and cube fish fillets. Remove all fat from meat and poultry and cut large vegetables into even slices or cubes.

Marinate foods for extra flavor and tenderness. Marinating times will vary for red meat, fish and or various cuts. Less tender cuts of meat should be marinated longer. Remember to always chill marinating food in the refrigerator prior to cooking.

Stir-fry meats, poultry or fish first. Next, add hard vegetables like carrots. Then continue with softer vegetables like snowpeas and peppers. To ensure even cooking, continually stir and toss the food in the wok using a wooden spoon or spatula.

#### Tips for Stir-frying

Place a wok on a Cooking Grid in the path of direct infrared heat. Add only a small amount of food at a time to ensure fast cooking and also to allow the wok to reheat between ingredients.

### DEEP-FRYING TECHNIQUES

A wide variety of foods can be deep-fried outdoors on your grill, from potatoes, to seafood and chicken. Deep-frying uses a large portion of oil, preferably saturated. The outdoor location is ideal for deep-frying as smoke, grease and smells disperse in the open air instead of collecting on the ceiling of your kitchen.

#### Preparing to Deep-fry

Deep-fry on your grill using an optional cast-iron pan placed on a Cooking Grid in the path of direct infrared heat.

Fill a cooking pan no more than half full of vegetable or corn oil. Turn the grill Burners on HI, close Lid and preheat your grill 3 to 5 minutes. Open Lid and place cast-iron pan on the mid section of a Cooking Grid then adjust the Infrared Burners to LOW.

Check the temperature of the oil carefully with a frying thermometer or test with a cube of bread. The cube of bread should brown in about 30 seconds for most cooking needs. 350°F(177°C) is the optimal temperature for preparing the majority of deep-fried foods.

#### Food Preparation

Foods being deep-fried taste better when coated with either batter or breadcrumbs to add flavor and prevent moisture from escaping.

#### Tips for Deep-frying

Wear a flame retardant BBQ Mitt and slowly lower foods into the hot oil using a wire scoop, fry-basket or stainless steel tongs. Add only a small quantity of food to the oil, allow it to cook, then repeat with another small quantity. This ensures the oil doesn't drop in temperature. Once the food is cooked, remove it carefully and drain onto a paper towel. Turn the heat off as soon as you have finished deep-frying and allow your pan to cool. When the oil is cool, remove all remnants of fried foods by straining it through a fine metal sieve, and store it in a clean bottle for future use.

## Guide to Using the Secondary Cooking Rack

Vegetables are generally easy to cook on the grill. The Secondary Cooking Rack makes it convenient because you can still use the main cooking area while the vegetables are suspended above the grids.

Pre-cook hard vegetables by briefly boiling or microwaving them before cooking on the grill. Do not grill your vegetables wrapped in aluminum foil. Infrared heat does not cook through aluminum foil and reflective pans. To keep vegetables moist, brush them with butter or oil often.

The Secondary Cooking Rack can be used for purposes other than just the obvious. Consider using the rack for warming French bread, garlic bread, croissants or even bagels.

**Question:**

**Can I convert my grill from one fuel type to another in other words from LPG to NG or vice versa?**

**Answer:**

No, your gas grill is manufactured to exact specifications and is certified for LPG (Liquid Propane Gas) or NG (Natural Gas) use only. For your safety, conversion kits are not available, nor will we sell or otherwise provide parts or information to be used to convert your grill. Any attempt to convert your grill is dangerous and will void your warranty.

**Question:**

**Are the serial and model numbers of my grill listed somewhere for reference?**

**Answer:**

The serial and model numbers are listed on a silver CSA label placed on the grill. Depending on the grill model the silver CSA label will be located on the left or right side bowl panel underneath the side shelf, underneath the right side of the control panel, outside left or right of control panel or on the back of the grill cabinet.

**Question:**

**My grill will not light properly. Why?**

**Answer:**

Always light the Main Burner farthest from the fuel source first. This will draw gas across the manifold helping prevent air pockets which obstruct gas-flow and prevent proper grill lighting. Also try this procedure:

1. Turn gas off at source and turn Control Knobs OFF. Wait at least 5 minutes for gas to clear, then retry.
2. If your grill still fails to light, turn the Burner Control Knob(s) and gas source OFF and conduct a leak test of ALL gas connections and gas sources as explained in the Use and Care section of this manual.
3. If no leaks are detected, wait 5 minutes for any gas to clear and repeat the lighting procedure.

**Question:**

**If my ignitor or battery is not working how can I light my grill manually? And - Why would I need the silver lighting stick that hangs from the side of my grill?**

**Answer:**

If your ignition fails to work or if your battery needs replacing, you can light your grill using the Manual Lighting Stick. The Lighting Stick is designed to hold a paper match and allows you to safely insert a match through the Cooking Grid without getting close to the Burner. To light your gas grill manually, insert a paper match into the Manual Lighting Stick and follow steps 1 through 5 of the Basic Lighting Procedures. Then, light the match and place the Lighting Stick through the Cooking Grid. Turn the nearest main Burner Control Knob to the  setting to release gas. The Burner should light immediately.



WARNING



**Never** lean over the grill cooking area while lighting your gas grill. Keep your face and body a safe distance (at least 18 inches) from the front of grill when lighting your grill by match.

**Question:**

**Sometimes I hear a humming sound coming from my regulator. What causes this? And - My grill has a low flame and sometimes will not light. Why?**

**Answer:**

The humming sound is gas flowing through the regulator. A low volume of sound is normal and will not interfere with the operation of your grill. Loud or excessive regulator humming and/or low flow and intermittent lighting may be caused by the regulator's excess gas flow device. Opening the tank valve all the way or too quickly is what triggers the regulator's safety device to restrict gas flow, preventing excess gas flow to your grill. Lighting the main Burner farthest from the fuel source every time will help eliminate air pockets in the manifold. Note: This procedure should be done every time a new LP Gas tank is connected to your grill.

- Turn all Control Knobs to the OFF position.
- Turn off the LP Gas tank at the tank valve. For Natural Gas shut off NG valve.
- Disconnect regulator from LP Gas tank. For Natural Gas disconnect regulator from 12 ft. Natural Gas Hose.
- Let unit stand for 5 minutes.
- Reconnect regulator to the LP Gas tank. For Natural Gas reconnect regulator to 12 ft. Natural Gas Hose.
- Open grill Lid.
- Turn the tank valve slowly ¼ of one turn. For Natural Gas open Shut Off valve.
- Light main Burner farthest from fuel source.
- Turn the tank valve slowly one more ¼ of one turn for ½ of one complete turn.
- Continue to light Burners moving towards the fuel source.
- Do not turn tank valve more than ½ of one turn on LPG models.

**Question:**

**Where do I use my grill for safer operation and better performance?**

**Answer:**

- Strong winds and low temperatures can affect the heating and performance of your gas grill so factor in these elements when positioning your grill outdoors for cooking.
- In **windy conditions**, always position the front of grill to face oncoming wind to reduce smoke and heat blowing in your face and prevent potential hazards to self and grill.
- Use your grill at least 3 feet away from any wall or surface.
- Use your grill at least 3 feet away from combustible objects that can melt or catch fire (ex: vinyl or wood siding, fences and overhangs) or sources of ignition including pilot lights on water heaters and live electrical appliances.
- Never** use your gas grill in a garage, porch, shed, breezeway or any other enclosed area.
- Never** use your gas grill on a balcony, deck, or patio above the ground floor of your home.
- Never** obstruct the flow of ventilation air around your gas grill housing.

**Question:**

**The Regulator and Hose supplied with my gas grill does not fit the older LP Gas tank I've used for years. Why not?**

**Answer:**

The U.S. Government regulates gas appliances and LP Gas tanks. When regulations are changed the LP Gas tank fittings are altered to insure compliance. If your LP Gas tank does not fit the Regulator and Hose supplied with your new grill, the tank is outdated and must be replaced. Note: Effective April 1, 2002 all LP Gas tanks sold must include an "OPD" Overfill Prevention Device. The OPD tanks are identified by their triangular-shaped valve wheel. This internal device prevents the LP Gas tank from being overfilled. Tanks without an OPD valve can not be refilled.

**Question:**

**What causes grill parts to rust and what effect does it have on my grill?**

**Answer:**

Rusting is a natural oxidation process and will not affect the short term performance of your grill.

To slow the rusting process on Cooking Grids we recommend greasing the grids before and after each cookout. Use a brush to apply a thin layer of cooking oil or vegetable shortening onto each grid. We do not suggest spray type oils unless they are specified for high-temperature cooking. If your Cooking Grids are Porcelain coated, be sure to coat the entire cooking surface including edges and any areas with chipped porcelain.

Routine care and maintenance is required to preserve the appearance and corrosion resistance of stainless steel. The fact is stainless steel can corrode, rust and discolor under certain conditions. Rust is caused when regular steel particles in the atmosphere become attached to the stainless steel surface. Steel particles can also become attached to your grill if you use steel wool or stiff wire brushes to clean the grill instead of non-abrasive cloth, sponge or nylon cleaning tools. In coastal areas rust pits can develop on stainless surfaces that cannot be fully removed. Bleach and other chlorine based solutions used for household and pool cleaning can also cause corrosion to stainless steel.

Weathering, extreme heat, smoke from cooking and machine oils used in the manufacturing process of stainless steel can cause stainless steel to turn tan in color. Although there are many factors which can affect the surface appearance of stainless steel, they do not affect the integrity of the steel or the performance of the grill. To help maintain the finish of stainless steel follow these cleaning procedures for the best results:

After every use (after your grill has cooled down), wipe stainless surfaces with a soft, soapy cloth or sponge then rinse with water. Be sure to remove all food particles, sauces or marinades from stainless steel because these can be highly acidic and damaging to stainless surfaces.

Never use abrasive cleaners, scrubbers or stiff wire brushes of any type on your grill. Use a heat resistant Stainless Steel Cleaner and rub or wipe in the direction of the stainless steel grain or polish lines. Do not polish against the grain.

## Grand Hall Limited Warranty

Grand Hall will warrant to the ORIGINAL PURCHASER of this product that it will be free of defects in material and workmanship for set periods below from the date of purchase when used under normal outdoor use and correct assembly:

Cooking Grids - 5 Year Limited Warranty(No rust through or burn through)

Infrared burners - 3 Year Limited Warranty

Valves and Plastic Components - 2 Year Limited Warranty

Electronic Components - 1 Year Limited Warranty

Cabinet - 3 Year Limited Warranty

Grill Head and Grease Tray - 10 Year Limited Warranty

All remaining parts - 2 Year Limited Warranty

Grand Hall will require reasonable proof of your date of purchase. Therefore, you should send in the owner registration card or register online at [www.grandhall.com](http://www.grandhall.com). Save your receipt in case it is required as proof of purchase.

This Limited Warranty is limited to replacement of parts at Grand Hall's option that proved to be defective under normal use and service.

Grand Hall may require the return of defective parts for examination before issuing replacement parts. If you are required to return defective parts, shipping charges must be prepaid. No returns will be accepted without prior authorization from Grand Hall.

Upon examination and to Grand Hall's satisfaction, if the original part is proven defective, Grand Hall may approve your claim and elect to replace such parts without charge. You will be charged for shipping and handling of the replacement parts.

This Warranty does not cover any failures or operating difficulties due to accident, abuse, misuse, alteration, misapplication, vandalism, improper installation, maintenance, operation or service, as set out in the Operator's Manual.

This Warranty does not cover cosmetic wear and tear such as scratches, dents, corrosion or discoloration caused by weather, heat, chemicals, paint loss, or surface rust. Deterioration or damage due to severe weather conditions such as hail, hurricanes, earthquakes, tsunamis, tornadoes, Act of God or terrorism is not covered by this Limited Warranty.

To Obtain Warranty:

Call 1-877-934-7455

Monday-Friday 8AM-4:30PM CST

Warranty Restrictions:

- This Warranty is non-transferable and is void if product is used for commercial or rental purposes.
- This Warranty applies only when the product is used in the United States or Canada.
- This Warranty gives you specific legal rights, and you may also have other rights which vary from state to state.

Manufacturer:

Grand Hall Enterprise Co., Ltd.

9th Fl., No. 298, Rueiguang Rd., Neihu,

Taipei, Taiwan (114)