

This Owner's Manual is provided and hosted by [Appliance Factory Parts](http://www.appliancefactoryparts.com).



# George Foreman RC0995P Owner's Manual

[Shop genuine replacement parts for George Foreman  
RC0995P](#)



[Find Your George Foreman Grill Parts - Select From 307 Models](#)

----- Manual continues below -----



# *Smart Kitchen*<sup>TM</sup>

MULTICOOKER

**GEORGE FOREMAN**<sup>®</sup>  
HEALTHY COOKING

***CUSTOMER CARE LINE:***

USA/Canada 1-800-231-9786

Accessories/Parts (USA/Canada)

1-800-738-0245

For online customer service  
and to register your product,  
go to [www.prodprotect.com/applica](http://www.prodprotect.com/applica)

***3-YEAR LIMITED WARRANTY***

Find additional healthy recipes at  
[www.georgeforemancooking.com](http://www.georgeforemancooking.com)

***MODELS***

- RC0995P***
- RC0995PQ***

# IMPORTANT SAFEGUARDS

When using electrical appliances, basic safety precautions should always be followed, including the following:

- Read all instructions.
- Do not touch hot surfaces. Use handles or knobs.
- To protect against electrical shock do not immerse cord, plugs or appliance in water or other liquid.
- Close supervision is necessary when any appliance is used by or near children.
- Unplug from outlet when not in use and before cleaning. Allow to cool before putting on or taking off parts, and before cleaning.
- Do not operate any appliance with a damaged cord or plug, or after the appliance malfunctions or has been damaged in any manner. Return appliance to the nearest authorized service facility for examination, repair or adjustment. Or, call the appropriate toll-free number on the cover of this manual.
- The use of accessory attachments not recommended by the appliance manufacturer may cause injuries.
- Do not use outdoors.
- Do not let cord hang over edge of table or counter, or touch hot surfaces.
- Do not place on or near a hot gas or electric burner or in a heated oven.
- Extreme caution must be used when moving an appliance containing hot oil or other hot liquids.
- Always attach plug to appliance first, then plug cord into wall outlet. To disconnect, turn any control to OFF, then remove plug from wall outlet.
- Do not use appliance for other than intended use.
- To reduce the risk of fire, cook only in removable container.
- Make sure base is properly assembled to cooking vessel. See instructions regarding assembly on page 6.

## SAVE THESE INSTRUCTIONS.

This product is for household use only.

### POLARIZED PLUG (120V Models Only)

This appliance has a polarized plug (one flat blade longer than the other) to reduce the risk of electric shock, this plug will fit in a standard wall outlet only one way. If the plug does not fit one way, do not reverse it. If it still does not fit, contact a qualified electrician to modify the plug in any way.

### TAMPER-RESISTANT SCREW

**Warning: This appliance is equipped with a tamper-resistant screw to prevent removal of the outer cover. To avoid electric shock, do not attempt to remove the cover to access serviceable parts inside. Repair should be performed by qualified personnel.**

### ELECTRICAL CORD

- a) A short power-supply cord (or detachable power-supply cord) should be provided to reduce the risk resulting from in or tripping over a longer cord.
- b) Longer detachable power-supply cords should be used if care is exercised in their use.
- c) If a long detachable power-supply cord is used:
  - 1) The marked electrical rating of the power-supply cord or extension cord should be at least equal to the rating of the appliance,
  - 2) If the appliance is of the grounded type, the power-supply cord should be a grounding-type 3-wire cord, and
  - 3) The longer cord should be arranged so that it does not drape over the countertop or tabletop where it can be pulled over.

**Note:** If the power supply cord is damaged, it should be replaced by qualified personnel; in Latin America, by an authorized service center.

Product may vary slightly from what is illustrated.

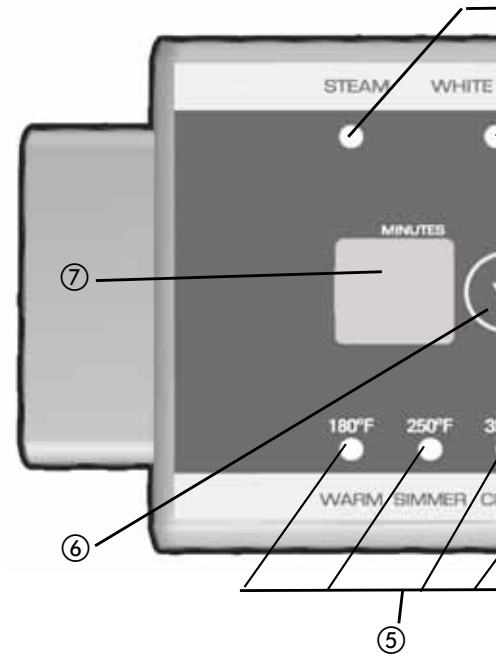
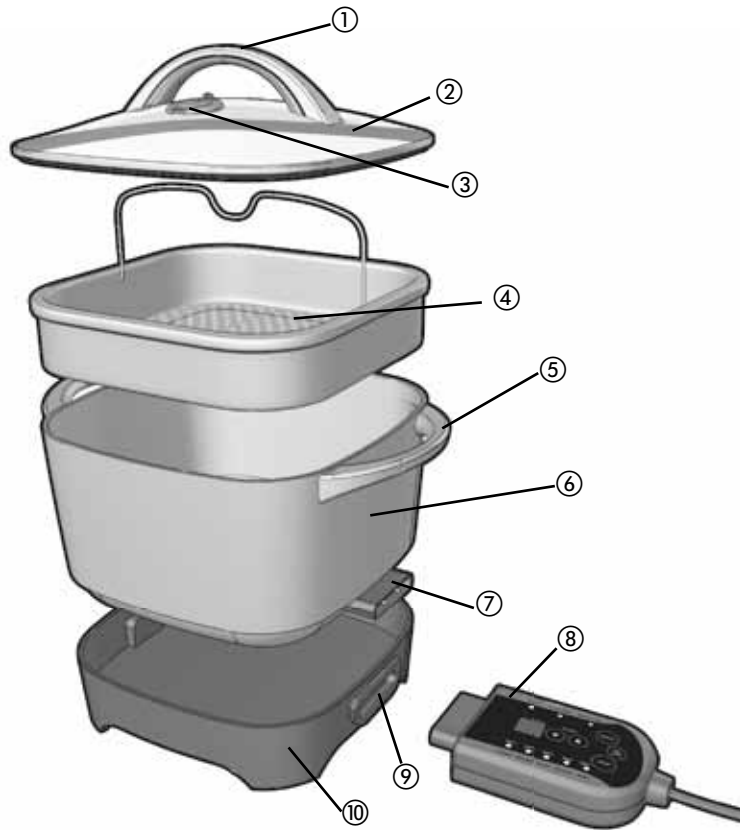

- 1. Lid handle
  - † 2. Tempered glass lid (Part # RC0995P-01)
  - 3. Adjustable steam vent
  - † 4. Steaming basket (Part # RC0995P-02)
  - 5. Pan handles (both sides)
  - † 6. Removable pan (Part # RC0995P-03)
  - 7. Probe socket
  - † 8. Intelli-Probe™ digital controls (Part # RC0995P-04)
  - 9. Probe socket opening
  - 10. Cooking base
  - 11. Pan release button (not shown)
  - †12. Rice measure (not shown) (Part # RC0995P-05)
  - †13. Serving paddle (not shown) (Part # RC0995P-06)
- Note: † indicates consumer replaceable/removable parts

- 1. Mode indicator lights
- 2. MODE button
- 3. ON/OFF button
- 4. TEMP button
- 5. Temperature indicator lights
- 6. TIMER ▼/▲ buttons
- 7. Digital display

# How to Use

This product is for household use only.

## GETTING STARTED

- Remove all packing material and, if applicable, any stickers from the product; remove and save literature.
- Please go to [www.prodprotect.com/applica](http://www.prodprotect.com/applica) to register your warranty; for additional information go to [www.georgeforemancooking.com](http://www.georgeforemancooking.com).
- Wash all removable parts and/or accessories as instructed in CARE AND CLEANING.
- Select a dry, level location where unit is to be used, leaving enough space between back of unit and wall to allow heat to flow without damage to cabinets and walls.

**Important:** This product is not a fryer. Do not cook with more than 1 – 2 tbsp. of oil or other fat at a time.

## INSERTING THE REMOVABLE PAN

**Caution:** Do not operate the multicooker without the cooking base attached.

1. Before placing the removable pan onto the base, be sure the heating plate and outside surface of the removable pan are clean and dry.

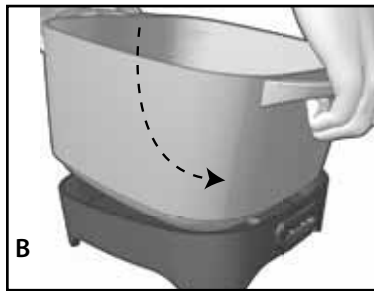

2. Insert removable pan onto base of the multicooker, making sure the probe socket is fitted correctly inside the opening on the right side of the base (B).
3. Press down on the pan release button on the cooking base and the removable pan clicks into place.

## USING THE INTELLI-PROBE™ DIGITAL CONTROLS

1. Insert control probe firmly into the probe socket.

**Important:** Be sure the control is securely inserted.

2. Uncoil cord and plug into standard electrical outlet. Two dashes will appear on the digital display.

**Note:** Always attach the control probe to the pan before plugging into an outlet.

3. Press the ON/OFF button; the word ON will appear in the display.

4. Select the desired setting based on what you are cooking:
  - To steam or cook rice, fill the removable pan with liquid. Tap the MODE button until the desired setting is illuminated.

OR

- To prepare other foods, tap the TEMP button until the desired temperature is illuminated:
  - 180°F Warm
  - 250°F Low
  - 350°F Medium
  - 450°F High
  - 500°F Sear

5. The red light under the selected temperature will illuminate when the temperature has reached the set temperature. It will then begin cooking.

## MAKING RICE

**Important:** As the rice expands and cooks, the lid will pop up. Do not place the multicooker directly under the lid.

**Caution:** To reduce the risk of electric shock, do not touch the lid when the multicooker is plugged in.

**Caution:** Do not operate the multicooker without the lid on.

1. Measure desired amount of rice with the provided rice measure.

**Note:** The rice measure provided is based on a maximum of 11 measures of dry rice—yielding 6 cups (or 6 oz. (by weight) for each cup of cooked rice).

2. Place rice in the removable pan. Add water, broth, or fruit juice. Use the water level marking on the inside of the pan for adding the right amount of water. Use the "COOKING BROWN RICE" and "WHITE RICE" for cooking brown rice and "WHITE RICE" for cooking white rice.

**Important:** Be careful not to add too much oil or butter.

**Note:** Taste/hardness will vary depending on the amount of water used and length of time the rice is cooked. Add a little more water. For firmer, crunchier rice, add less water. Experiment to suit your taste.

3. Add butter, oil and/or seasonings as desired.
4. Place the lid on the removable pan with the handle facing away from you, and not toward your cabinets.

**Note:** Always keep the lid on the multicooker when it is plugged in.

5. Plug into a standard electrical outlet. Two dashes will appear on the digital display.

6. Press the ON/OFF button; the word ON will appear in the display.

**Caution:** Do not put your hand over the steam vent when the multicooker is cooking. The hot steam can burn you.

7. Select WHITE or BROWN rice.
8. Once rice is cooked, the multicooker automatically switches to WARM and the red light above WARM turns on. The WARM function will operate until the appliance is turned off.
9. Let rice rest for about 15 minutes on WARM before serving. Fluff rice with a fork before removing from the appliance.

**Important: Do not immediately press the ON/OFF button again after it has begun the WARM cycle.**

10. Remove the lid and fluff the rice before serving.

**Caution: When removing the lid, tilt away from your body to avoid getting burned with the hot steam.**

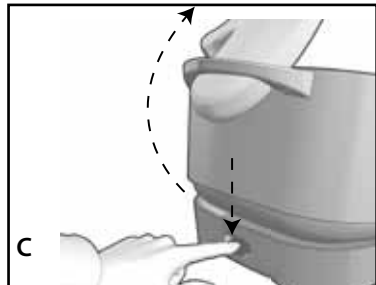

11. To take the removable pan to the table for serving, unplug the probe from the wall, then remove the digital control probe. Press the pan release button on the left side of the base. Tilt the removable pan up on the opposite side of the probe to disengage the probe socket from the base (C). Using pot holders, lift the removable pan up by both handles.

**Caution: Be careful when removing the pan for serving, as it will still be warm from cooking. Do not remove the pan from the base when making a stew or any other food which contains a large amount of liquid.**

12. Press the ON/OFF button and unplug the multicooker when finished cooking.

**Important Tips:**

- Do not keep small amounts of rice on WARM for extended periods of time.
- During cooking, a thin crust may develop on the rice at the bottom of the bowl.
- Fluff the rice before serving.
- Use the plastic serving scoop (rubber spatula or a wooden spoon) to stir and remove rice. Do not use metal utensils that can scratch the nonstick removable pan.

## RICE COOKING GUIDE

If desired, add seasoning and oil or butter.  
Allow rice to rest in appliance at least 15 minutes.

### FOR LONG GRAIN RICE:

#### USE MARKINGS FOR OTHER RICE

| AMOUNT OF RICE   | AMOUNT OF WATER |   |
|------------------|-----------------|---|
| 2 rice measures  | to 2 mark       | 1 |
| 3 rice measures  | to 3 mark       | 2 |
| 4 rice measures  | to 4 mark       | 2 |
| 5 rice measures  | to 5 mark       | 3 |
| 6 rice measures  | to 6 mark       | 3 |
| 7 rice measures  | to 7 mark       | 3 |
| 8 rice measures  | to 8 mark       | 3 |
| 9 rice measures  | to 9 mark       | 4 |
| 10 rice measures | to 10 mark      | 4 |
| 11 rice measures | to 11 mark      | 4 |

### FOR BROWN RICE:

#### USE MARKINGS FOR BROWN RICE

|                  |           |   |
|------------------|-----------|---|
| 2 rice measures  | to 2 mark | 4 |
| 3 rice measures  | to 3 mark | 4 |
| 4 rice measures  | to 4 mark | 5 |
| 5 rice measures  | to 5 mark | 5 |
| 6 rice measures  | to 6 mark | 6 |
| 7 rice measures  | to 7 mark | 6 |
| 8 rice measures  | to 7 mark | 7 |
| 9 rice measures  | to 7 mark | 7 |
| 10 rice measures | to 7 mark | 7 |
| 11 rice measures | to 7 mark | 8 |

### USING THE STEAMING BASKET

1. Before placing the removable pan onto the base, be sure the heating plate and outside surface of the cooking bowl are clean and dry. Do not let loose particles fall into the base.
2. Insert removable pan onto base, making sure the probe socket is fitted correctly inside the opening on the base.
3. Fill the removable pan with at least 2 cups of water, broth or juice using a standard measuring cup.
4. Place vegetables or other food in the steaming basket and position the basket on top of the removable pan. Season food with salt, pepper and desired seasonings.
5. Place the lid on the removable pan.

**Note:** Always keep the lid closed while cooking.

6. Plug unit into a standard electrical outlet. Two dashes will appear on the digital display.
7. Press the ON/Off button; the word ON will appear in the display.
8. Press the MODE button; the red light will be illuminated below the word STEAM.
9. Set timer to desired cooking time. Steaming times vary according to vegetable or food type.
10. Timer will begin to count down once liquid in removable cooking pan comes to a boil.
11. Begin checking for doneness after initial 5 minutes. You may need to experiment to suit your taste.
12. When cooking is complete, press the ON/OFF button and unplug the unit.

| STEAMING GUIDE  |                        |  |
|---|------------------------|--|
| Steam using 2 cups of cold tap water, stock or broth. |                        |  |
| VEGETABLE   | AMOUNT                 | PREPARATION                                      |
| Fresh asparagus                                       | 1 lb.                  | Wash; trim woody ends where snap ends.           |
| Fresh green beans or waxed beans                      | 1 lb.                  | Leave ends; trim ends into 2" pieces.            |
| Fresh beets   | 1 lb. (about 5 medium) | Remove tops and roots; peel and cut into wedges. |
| Fresh broccoli  | 1 bunch (about 8 cups) | Cut into florets.                                |
| Brussels sprouts                                      | 4 cups                 | Cut a notch in the base of each sprout.          |
| Cabbage   | 1 lb.                  | Cut into wedges.                                 |
| Carrots   | 12 oz.                 | Cut into slices.                                 |
| Cauliflower   | 12 oz.                 | Cut into florets.                                |
| Celery  | 12 oz. (about 2½ cups) | Cut into pieces.                                 |

| VEGETABLE       | AMOUNT                   | PREPARATION             | TIME            | SUGGESTIONS  |
|-----------------|--------------------------|-------------------------|-----------------|--|
| Corn            | 1½ lb.<br>(about 4 ears) | Cut in 2" pieces.       | 8 – 10 minutes. | Garnish with finely chopped tomatoes and parsley.      |
| Sugar snap peas | 8 oz.<br>(about 2 cups)  | Trimmed and left whole. | 6 – 8 minutes.  | Season with salt, pepper and minced dill.              |
| Snow peas       | 8 oz.                    | Trimmed and left whole. | 6 – 8 minutes.  | Serve drizzled with soy sauce and minced green onions. |

## PREPARING SOUPS & STEWS

**Note:** Use only boneless meats and poultry in 1-inch pieces. It is not necessary to brown the meat. As soon as the multicooker begins to cook, steam will come out of the vent.

**Important: Do not place the multicooker on a wooden surface.**

**Note:** When cooking rice or pasta in the steamer basket, use the MAX fill line.

**Caution: To reduce the risk of electric shock, do not touch the heating element.**

**Note:** Do not fill removable pan with oil above the MAX fill line. The removable pan should only be used up to the MAX fill line.

1. Before placing the removable pan onto the multicooker, make sure the outside surface of the cooking bowl are clean and dry so they do not fall into the base.
2. Insert removable pan onto base, making sure it is seated inside the opening on the base.
3. Plug unit into a standard electrical outlet.
4. Press the ON/OFF button; the word ON will appear on the display.
5. Press the TEMP button; the red light below the button will flash when the set temperature is reached.
6. You can change the temperature at any time. If a lower temperature is desired, continue to press the TEMP button until the flashing or illuminated below the desired temperature.
7. If desired, you can brown meats or sauté vegetables. (When the appliance is turned on, select the desired temperature. For sautéing, select 350°F.) Do not crowd meats or vegetables.
8. Combine meats, vegetables and liquids in the removable pan or plastic spoon until ingredients are well combined.

**Note:** Since most frozen vegetables cook very quickly, reduce the cooking time. Stir them into the soup or stew during the additional 5 to 10 minutes.

**Caution: Do not fill removable pan higher than the MAX fill line on the removable pan.**

9. Place the lid on removable pan.

**Note:** Always keep lid on multicooker while cooking.

10. As the soup or stew cooks, steam may come out of the vent.

**Caution: Do not put your hand over the steam vent. Do not touch the hot steam.**

11. Set timer for desired cooking time.

12. If desired, stir several times during the cooking time.

**Caution: When removing the lid, tilt away from you to avoid being hit with the hot steam.**

13. Place lid back on the removable pan when stirring is done.
14. If desired, check seasoning level during cooking and add additional seasoning to taste.
15. When cooking is complete, press the ON/OFF button and unplug the unit.

**Caution: Always unplug the unit when cooking is complete.**

**Important Tips:**

- Always use the timer and monitor cooking carefully.
- Use only boneless meats and poultry that are cut into cubes no larger than 1½ inches. It is not necessary to brown the meats before cooking.
- When cooking rice or pasta in the soup, allow for additional liquid in the recipe.
- Since most frozen vegetables cook very quickly, it is best to add them at the end of the cooking time. Stir them into the soup or stew and allow the mixture to cook an additional 5 to 10 minutes.

## Care and Cleaning

This appliance contains no user-serviceable personnel.

### CLEANING

1. Unplug the cord and let multicooker cool.
2. Make sure the digital control probe is retracted.
3. Wash the removable pan and lid with warm soapy water. Wash in the dishwasher, top-rack only.

**Important: Do not immerse the removable pan or lid in liquid or use a sponge or nylon scouring pad with liquid detergent.**

**Important: Do not use any abrasive cleaners on the nonstick coating.**

4. Rinse and dry all parts thoroughly.
5. Wipe the base with a damp cloth and dry thoroughly.

### STORAGE

Store the skillet in a dry place and wind electrical cord with a twist tie.

## TROUBLESHOOTING

| PROBLEM  | POSSIBLE CAUSE   | SOLUTION   |
|--|--|--|
| Some kernels of rice do not seem fully cooked.   | The rice was not allowed to finish cooking.            | Allow rice to rest for 15 minutes after cooking before serving.  |
| Removable pan is not as clean as I would like.   | Starch builds up on sides and bottom of removable pan. | Fill pan with hot, soapy water and let stand several minutes; then use a nylon scrubber along sides and bottom; rinse well and dry thoroughly. |
| Rice boils over.                                 | Too much rice is being cooked.                         | Make sure to cook no more than the maximum amount suggested. The amount of rice to be cooked should match the water markings on the bowl.      |
| Rice is too dry.                                 | Too much rice or not enough water.                     | Use the rice measure that comes with the multicooker. The rice measure provided holds about 5½ oz.   |
| Rice is gummy.                                   | Too much water or not enough rice.                     | Add water to match markings on the rice bowl. <b>Do not use a liquid measuring cup.</b>  |
| Mixture cooking is boiling and I want to simmer. | Temperature selection may be too high.                 | Tap the TEMP button to select a lower temperature (we suggest 250°F to simmer).  |

## Recipes

### FEIJOADA, BRAZILIAN PORK STEW

3 ounces pancetta, diced  
 1 lb. pork loin, cubed  
 ½ lb. ham, cubed  
 ½ lb. linguica, thickly sliced  
 ½ lb. smoked pork sausage  
 1 large onion, chopped  
 4 large cloves garlic, chopped  
 1½ cups beef broth  
 1 can (14 ½ oz.) diced tomatoes  
 1 can (16 oz.) black beans, rinsed and drained  
 1 cup coarsely chopped green pepper  
 2 oz. rinsed dried beef, cut into 1-inch pieces  
 ¼ cup chopped cilantro  
 1 bay leaf  
 1 tsp. dried oregano  
 ½ tsp. seasoned pepper  
 2 tbsp. cornstarch  
 ¼ cup beef broth or water  
 Hot cooked rice  
 6 oranges, sectioned

Preheat multicooker at 350°F. Add pancetta and set aside.

Add pork and ham and brown well on all sides. R

Add sausages and brown on cut sides. Add to pan onion is softened. Add broth, tomatoes, black be pepper into removable pan. Return meats to pan to 250°F and cook for 20 minutes.

Blend cornstarch into beef broth. Stir into stew and

Serve over rice and garnish with orange segments.

Makes about 12 cups (about 3 quarts; 2.8 liters).

### **MOROCCAN BEEF STEW**

3 lb. top round, cut in 1½-inch cubes

1 tbsp. olive oil

1 large purple onion, cut in wedges

3 large cloves garlic, minced

4 cups beef broth or stock

½ cup dry red wine

1½ tsp. ground cumin

1½ tsp. salt

1 tsp. ground cinnamon

½ tsp. coarse ground black pepper

1 lb. sweet potatoes, peeled and cut into 1-inch chunks

1 pkg. (7 oz.) dried apricots

3 cups baby spinach

Hot cooked rice

Greek yogurt

Preheat multicooker at 350°F. Add enough beef cubes to pan without any touching and brown on all sides. Remove and set aside. Repeat with remaining beef until all pieces are browned.

Add onion and garlic and cook until onion is softened. Add broth and seasonings. Return meats to pan. Cover and bring to a boil. Reduce temperature to 250°F and cook for 40 minutes.

Add sweet potatoes and apricots and cook 15 minutes or until sweet potatoes are tender. Add spinach and cook 2 minutes.

Serve over rice and garnish with yogurt.

Makes about 10 cups (about 2.5 quarts; 2.4 liters).

### **BROWN RICE AND SQUASH BLEND**

1 pkg. (8 oz.) mushrooms, sliced

2 tbsp. butter or margarine

1 large onion, chopped

3 large cloves garlic, minced

4 cups white wine and culinary broth

1½ cups brown rice blend (such as Lundberg)

1 medium butternut squash, peeled, seeded and

½ cup dried cranberries

1 tsp. salt

½ tsp. coarse ground pepper

Preheat multicooker at 350°F. Brown mushrooms and cook until onion is softened. Add broth and bring

Set temperature control to BROWN rice. Cover and cook until liquid is absorbed.

Makes about 7 cups (about 1.25 quarts; 1.7 liters)

### **SPAGHETTI WITH MEATBALLS**

1 jar (1 lb., 10 oz.) marinara sauce

3½ cups water

½ lb. spaghetti rigati or linguini

1 lb. frozen meatballs (½-inch size)

2 large cloves garlic, minced

2 tbsp. chopped parsley

1 tsp. dried Italian herbs

Preheat multicooker at 350°F. Combine all ingredients and cook until mixture comes to a boil, reduce heat to 250°F and

Place the lid back on the multicooker. If necessary, cook until meatballs are tender. Serve immediately.

If desired, garnish each serving with freshly grated

Makes about 8 cups / 4 servings (about 2 quarts; 1.9 liters)

### SPICED SHRIMP AND RICE

- 1 pkg. (16 oz.) yellow rice mix
- 2 cups chicken or vegetable broth
- 1 bottle (8 oz.) clam juice
- 1 can (14½ oz.) diced tomatoes with green chilies
- 2 tbsp. olive oil
- 1½ lb. shrimp, shelled and deveined
- 1 large onion, chopped
- 2 large cloves garlic, minced
- ¼ cup chopped cilantro
- ½ tsp. coarsely ground black pepper
- 1½ cups frozen peas

Combine all ingredients, except peas in removable pan in order listed. Place pan onto base and plug in the appliance. Set temperature at 350°F. Place the lid on the cooker.

Set timer and cook for 26 minutes. Stir in frozen peas; place the lid back on the cooker and cook an additional 10 minutes. Serve immediately.

Makes about 9 cups / 4 to 5 servings (about 2.25 quarts; 2.1 liters).

**Note:** One can (14½ oz.) diced tomatoes and 1 can (4 oz.) diced green chilies can be substituted for the canned tomatoes with green chilies.

### CLASSIC CHICKEN STEW

- 1½ lb. boneless chicken cut into 1-inch cubes
- 2 cans (10¾ oz, each) condensed cream of chicken with herbs soup
- 1 cup water
- 4 medium carrots, cut in 1-inch pieces (about 1½ cups)
- 4 medium red skin potatoes, quartered
- 3 stalks celery, thickly sliced (about 1½ cups)
- 2 medium leeks, halved and sliced
- ½ tsp. coarsely ground black pepper
- 1½ cups frozen cut green beans

Combine all ingredients, except frozen vegetables in removable pan in order listed. Place pan onto base and plug in the appliance. Place the lid on the cooker. Set temperature at 350°F. Once mixture comes to a boil, reduce heat to 250°F and cook for 45 minutes. Stir in frozen green beans; place the lid back on the cooker and cook an additional 10 minutes. Serve immediately.

Makes about 10 cups / 5 to 6 servings (about 2½ quarts; 2.4 liters).

### TERIYAKI SALMON

- 1 lb. salmon fillets
- ⅓ cup teriyaki or toasted sesame marinade
- 1 can (8 oz.) mandarin oranges
- 1 cup snow peas
- 4 green onions cut in 1-inch pieces
- 1 tsp. kosher salt
- ¼ tsp. seasoned pepper
- ¼ cup toasted sliced almonds

Place filets in shallow baking dish. Pour marinade over salmon. Refrigerate for at least 30 minutes.

Drain oranges, saving liquid. Set oranges aside. Add snow peas and green onions to rice cooking bowl. Season with salt and pepper.

Cover and plug appliance into electric outlet. Set temperature at 350°F. Top with reserved mandarin oranges. Cook 3 minutes.

If desired, serve over cooked rice and drizzle cooking liquid over salmon.

Makes 4 servings.

### CHILI SHRIMP

- 1 lb. shrimp, shelled and deveined
- 1½ cups thinly sliced yellow squash
- 1½ cups thinly sliced zucchini
- 1 medium red pepper, seeded and cut into 2-inch pieces
- 2 large cloves garlic, thinly sliced
- 1 tbsp. chopped fresh basil
- ¼ tsp. chili powder
- ¼ tsp. salt

In large bowl, combine all ingredients; toss to blend. Add 1¼ cups cold tap water to rice cooking bowl. Place shrimp mixture into steamer basket. Insert steamer basket into rice cooking bowl.

Cover and plug appliance into electric outlet. Set temperature at 350°F. Set timer and cook for 20 minutes; test shrimp and cook several more minutes.

If desired, garnish with chopped cilantro and lemon wedges.

Makes 4 servings.

## **NEED HELP?**

For service, repair or any questions regarding your appliance, call the appropriate 800 number on cover of this book. Please DO NOT return the product to the place of purchase. Also, please DO NOT mail product back to manufacturer, nor bring it to a service center.

You may also want to consult the website listed on the cover of this manual.

### **Three-Year Limited Warranty**

**(Applies only in the United States and Canada)**

#### **What does it cover?**

- Any defect in material or workmanship provided; however, Aplica's liability will not exceed the purchase price of product.

#### **For how long?**

- Three years from the date of original purchase with proof of such purchase.

#### **What will we do to help you?**

- Provide you with a reasonably similar replacement product that is either new or factory refurbished.

#### **How do you get service?**

- Save your receipt as proof of date of sale.
- Check our on-line service site at [www.prodprotect.com/aplica](http://www.prodprotect.com/aplica), or call our toll-free number, 1-800-231-9786, for general warranty service.
- If you need parts or accessories, please call 1-800-738-0245.

#### **What does your warranty not cover?**

- Damage from commercial use
- Damage from misuse, abuse or neglect
- Products that have been modified in any way
- Products used or serviced outside the country of purchase
- Glass parts and other accessory items that are packed with the unit
- Shipping and handling costs associated with the replacement of the unit
- Consequential or incidental damages (Please note, however, that some states do not allow the exclusion or limitation of consequential or incidental damages, so this limitation may not apply to you.)

#### **How does state law relate to this warranty?**

- This warranty gives you specific legal rights, and you may also have other rights that vary from state to state or province to province.

Made in People's Republic of China  
Printed in People's Republic of China



*Cook what you love, only healthier*

**Applica®**  
Applica Consumer Products, Inc.

© 2010 Applica Consumer Products, Inc.

R4 2010/6-7-36E