

This Owner's Manual is provided and hosted by [Appliance Factory Parts](#).



Breezair TBA 450 Owner's Manual

[Shop genuine replacement parts for Breezair TBA 450](#)



[Find Your Breezair Evaporative Cooler Parts - Select From 61 Models](#)

----- Manual continues below part list -----

Available Replacement Parts for Breezair TBA 450

401959	PIN, RETAINING
401966	DISC
901497	FLOAT BREEZEAIR COOLER
834320	SOLENOID VALVE
095905	Tornado Water Pump 230V
105345	24V Auto Drain
114606	Chillcel Pad 20.75 x 33.5 x 3.5 Set of 4
114880	CPMD J-box Variable Speed
833811	Probe water sensor

installation manual

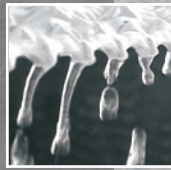
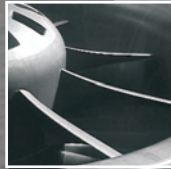

° English
"Export Edition"
839479-D
0703

Breezair[®]
TBA Evaporative Air Cooler

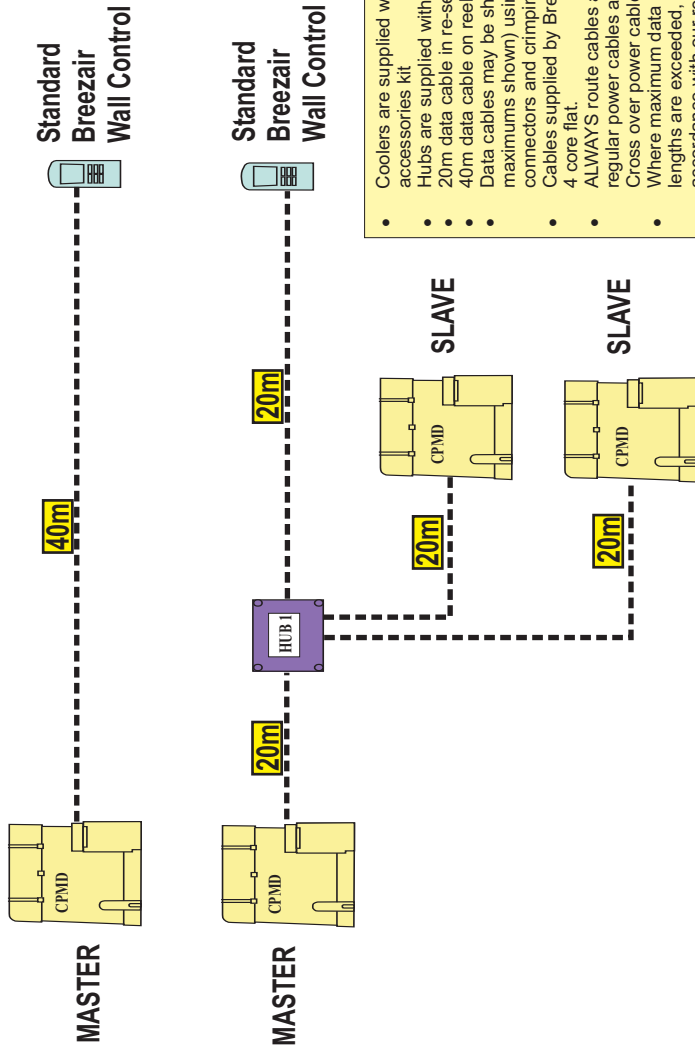

- Coolers are supplied with 20m data cable in accessories kit
- Hubs are supplied with 20m data cable in kit.
- 20m data cable in re-sealable bag available
- 40m data cable on reel available
- Data cables may be shortened or lengthened (to maximums shown) using ONLY correct RJ connectors and crimping tools
- Cables supplied by Breezair are 26AWG, 7/016, 4 core flat.
- ALWAYS route cables at least 300mm away from regular power cables and high power machines. Cross over power cables at right angles.
- Where maximum data cable and sensor cable lengths are exceeded, or cables are not routed in accordance with our recommendations Seeley technical support is not available and the product warranty may be voided.

Please read this manual carefully. Your failure to do so could result in injury to you or damage to the cooler and property.

Disconnect electrical power at the fuse or circuit breaker box and turn "OFF" the isolating switch located inside the cooler on the Electronics Module before you begin to install the cooler.

Always comply with your local laws and safety regulations.

INSTALLATION & OPERATION

- Installation of the cooler must comply with local electrical, water supply and environmental codes, laws and safety regulations as well as with applicable National Standards.
 - Dress safely. Wear non-slip shoes at all times. Open shoes, sandals and bare feet are NOT safe when working with tools and machines. Do not wear loose clothing and decorations while installing the cooler as they can get caught in the moving parts.
 - Keep long hair, loose clothing and fingers away from moving parts.
 - Do not install the cooler during rain, high winds, or severe weather conditions.
 - The appliance is not intended for use by young children or infirm persons without supervision.
 - Young children should be supervised to ensure that they do not play with the appliance.
 - Wear protective clothing when working with power tools.
 - Always ensure that electrical power cables conform to relevant government safety requirements.
 - Always lift the cooler to its location using safe methods and equipment.
 - Never drain the cooler directly onto the roof. Always use pipes to carry the drain water to a proper point. Failure to do this can stain the roof and make the roof slippery and unsafe.
 - All installation, maintenance and repair work must be done by trained and qualified technicians.
 - The plastic packaging from the cooler can be a safety hazard. Please dispose of it in accordance with local laws and regulations.
 - ALWAYS route cables at least 300mm away from regular power cables and high power machines. Cross over power cables at right angles.
 - Where maximum data cable and sensor cable lengths are exceeded, or cables are not routed in accordance with our recommendations Seeley technical support is not available and the product warranty may be voided.
-

ELECTRICAL

It is a requirement of Seeley International that the electrical power supply to all coolers is not mixed with other machines or electrical circuits. Electrical installation must comply with local laws and regulations. Each cooler requires a minimum 10 amp power supply.

Specification :

**115V, 230V / 50Hz, 60 Hz
Single Phase (see nameplate for
exact data for this air cooler.)**

The electronics module is fitted with a 12 amp manual reset circuit breaker. To reset the circuit breaker turn off the isolation switch, remove the Electronics Module and push the manual reset toggle switch located underneath the Electronics Module. The isolation switch on the module cannot be turned on without the securing screw being in place.

If at any time the electrical supply cable is damaged, it must be replaced by a special cord or assembly available from the manufacturer or its service agent in order to avoid a hazard.

WATER**Specification :**

Water Connections : 1/2 inch BSP

Maximum pressure: 800 KPa (115 PSI)

IMPORTANT: If the water pressure exceeds 800KPa, then a pressure reducing valve must be fitted near to the air cooler by the installer.

The air cooler will function best when clean water is supplied. Water that contains dissolved salts and other impurities will cause the cooling pads to become blocked more quickly and then they require maintenance. The water management devices fitted will help to control the effects of poor quality water, BUT THEY CANNOT ELIMINATE THE PROBLEM.

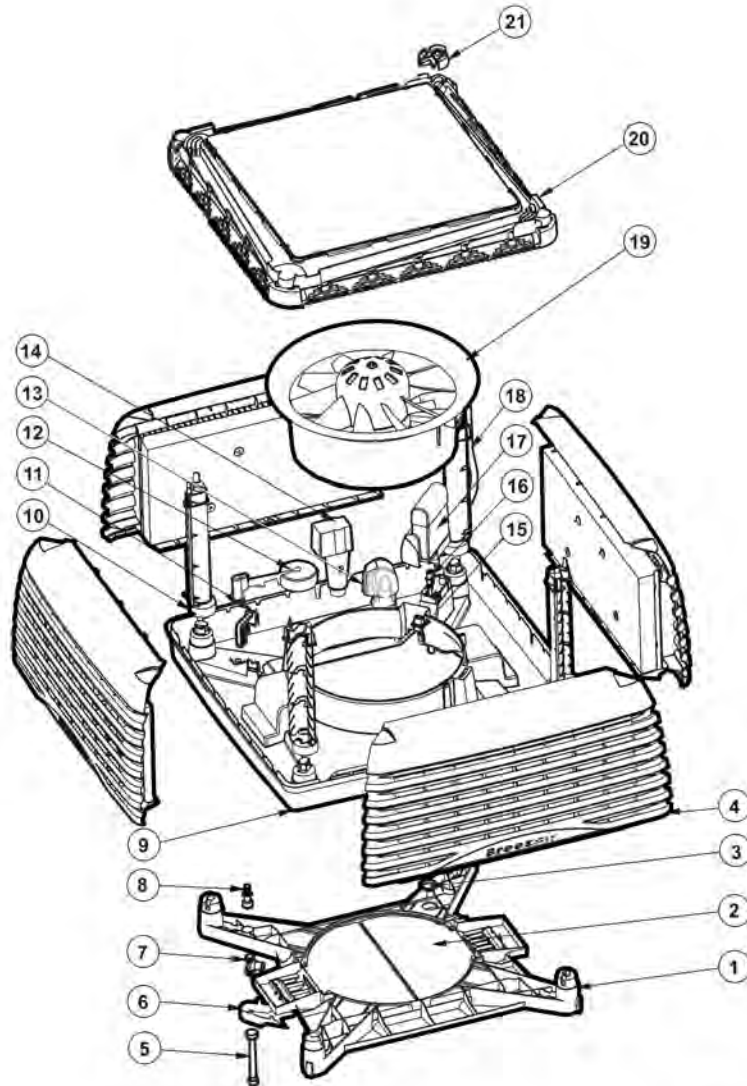

1. Transition (used for the transport base, this becomes the the air cooler base for connection to the duct)
 2. Weatherseal (stops air flowing in and out when the air cooler is not operating)
 3. Transition Plug (fitted in the factory)
 4. Cooling Pad Frame
 5. Flexible Hose (for mains water connection)
 6. Solenoid Valve Cover
 7. Solenoid Valve
 8. Extension Tube (connects the Float Valve to the Solenoid Valve)
 9. Water Tank (reservoir)
 10. Corner Pillar
 11. Water Sensor (detects conductivity of water)
 12. Float Valve (for control of main water supply level in the Water Tank)
 13. Water Pump
 14. Drain Valve (for releasing water in the tank automatically or when the user requires)
 15. Motor Cable with two plugs
 16. Electric Power Supply Cable with plug
 17. Electronics Module
 18. Pump Hose
 19. Venturi/Fan Assembly
 20. Lid
 21. Distributor Cap (for directing water from the pump into the water distribution channels in the lid)
-

The air cooler is designed to be partially dismantled in order to reduce the weight for installation.

COOLING PAD FRAME REMOVAL

To remove the Cooling Pad Frame, first disengage the top clips of the pad frame using a screw driver as shown.

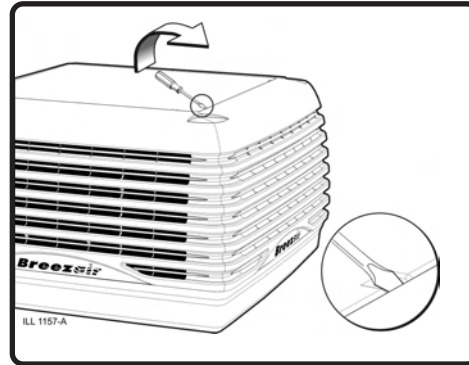

Then hold the pad frame with both hands and pull it towards you as shown. See diagram. This disengages the side clips.

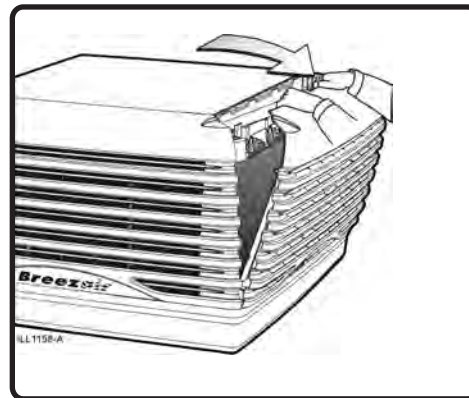

Then lift the frame up and out as shown. See diagram. Do this with each Cooling Pad Frame.

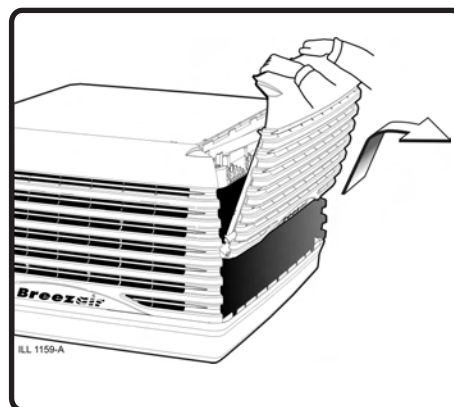

REMOVING THE VENTURI/FAN

IMPORTANT! Ensure the motor plug has been removed from the control box before removing the venturi (see page 9 for removal of plug).

With both arms hold each side of the Venturi/fan assembly. Press the large clips at each side and lift the Venturi/fan assembly upwards and carry it out of the cabinet.

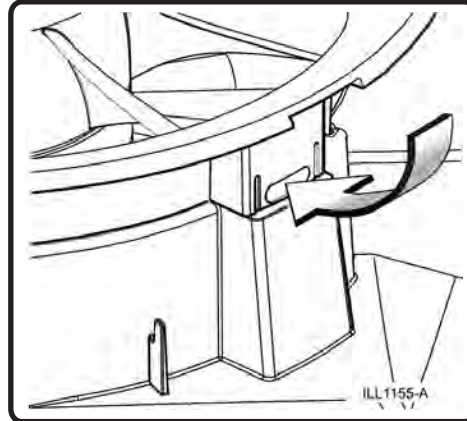

Place the Venturi/fan assembly carefully aside until the cooler has been completely installed.

You cannot install the various components of the air cooler unless you remove the Venturi/fan assembly first.

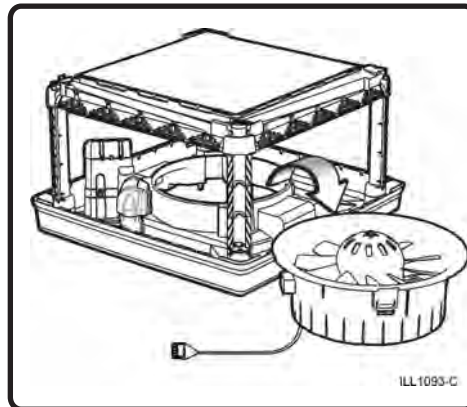
**REMOVING THE TRANSITION**

Turn the cooler onto its side to remove the Transition. It is held to the cabinet for transport with big clips. The Transition can be pulled off the cabinet with a strong pull by the installer. If it is difficult to remove, squeeze the clips together and then pull. See diagram. The Transition is now ready to be fitted onto the duct.

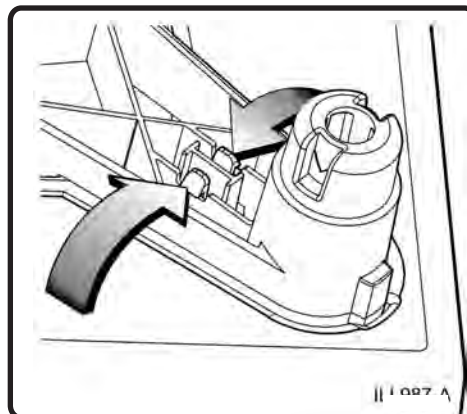

The air cooler is designed to be fixed to the first section of the duct without any additional frame for support. Therefore make sure the duct is fixed to the building using a strong method.

The duct size must be 550 x 550mm. The top edge must be strong without any flange. The top edge of the duct must be level. The Weathersel requires a 270mm section of straight duct under the air cooler before a bend is installed. Do not penetrate the duct with any fasteners in this section.

The best location for the cooler is where the air is fresh and clean. Keep away from exhaust vents from factories and commercial kitchens. Do not locate the air cooler near the ground where there is dust and pollution.

The sides of the cooler should be a minimum of 600mm from any wall.

If the cooler is located on a platform, **always build a safety rail around the platform.**

Place the transition onto the duct. If the roof is sloped then make sure the transition is located correctly according to the diagram.

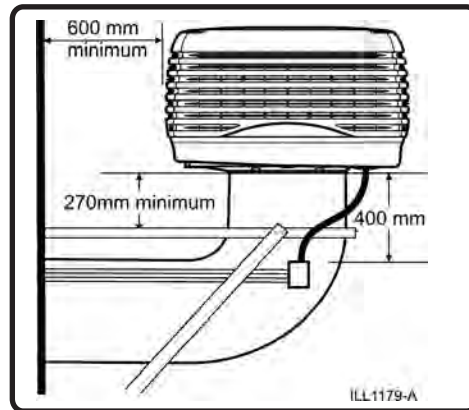

ILL1179-A

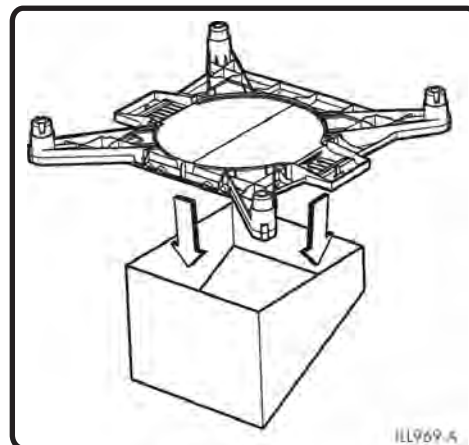

ILL969-A

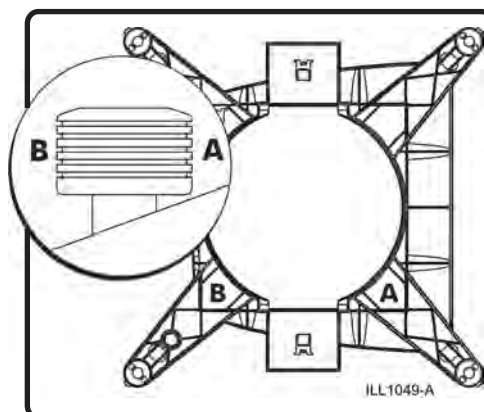

ILL1049-A

Use a spirit level in both directions to get the Transition level. Screw it to the duct using the eight (8) screws provided. There are eight (8) V-notch locations for the screws. See diagram.

Now break off both clips on the Transition that retain the Weatherseal.

IMPORTANT: There must be no obstructions to the weatherseal opening fully as that will reduce the air cooler performance .

Check that the weatherseal flaps do not interfere with the duct or any screws. The flaps should move freely through 90°. See diagram.

Lift the air cooler up and place it onto the Transition. It will only go one way. Make sure the clips in the four corners engage correctly. See Diagram. Do not use any screws to attach the air cooler.

IMPORTANT
Do not place the venturi assembly into the air cooler at this stage.

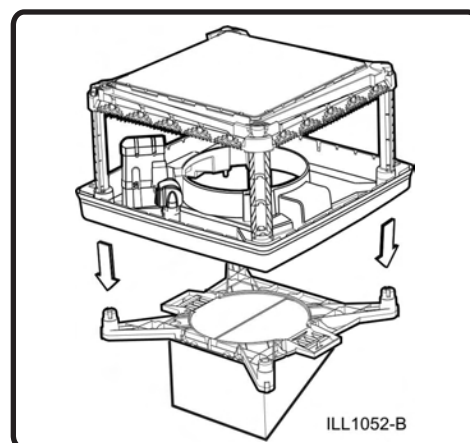
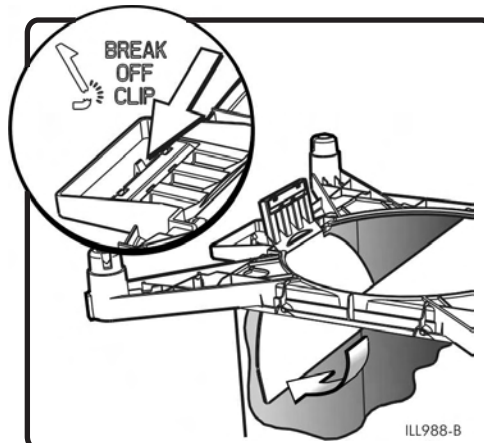
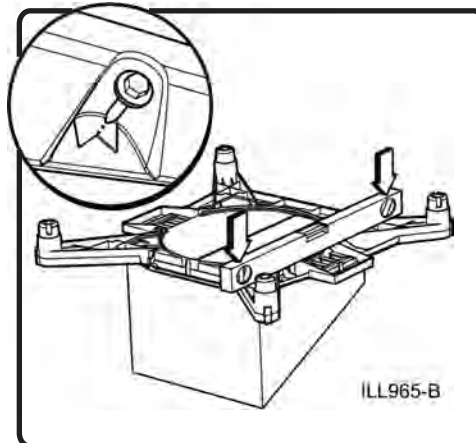

Disconnect the Electronics Module from the Water Tank by removing the screw under the isolation switch. See diagram. The switch cannot function with this screw removed.

The installation kit supplied contains your power cable with ends ready to terminate and a wall control cable. Take the power cable and drop the the non-plug end down the hole where the Electronics Module was and pass it through the conduit adaptor (factory fitted in the Transition). Then lock the plug on the other end in place as shown - see diagram. Pass the taped end of the wall control cable through the conduit adaptor also and leave about 0.5m in the Water Tank.

Now pass the cables through your main conduit and connect the main conduit to the conduit adaptor (under the Transition).

IMPORTANT: Pass the wall control cable through the conduit first.

Terminate the power cable in a junction box installed nearby. **The fixed wiring must be fitted with an isolation switch that breaks active and neutral in accordance with wiring rules.** We recommend the junction box is located on the duct. **Do not penetrate the duct near the Weatherseal.** Note: The maximum length for the wall control cable to travel alongside the power cable is 10m.

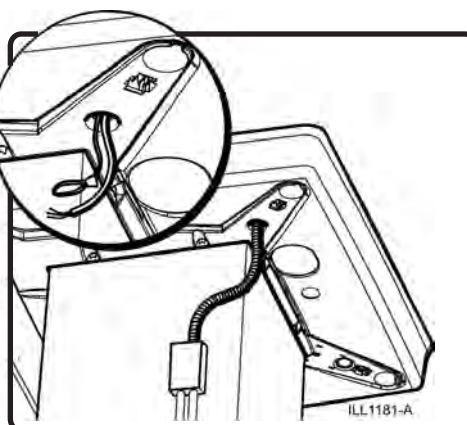
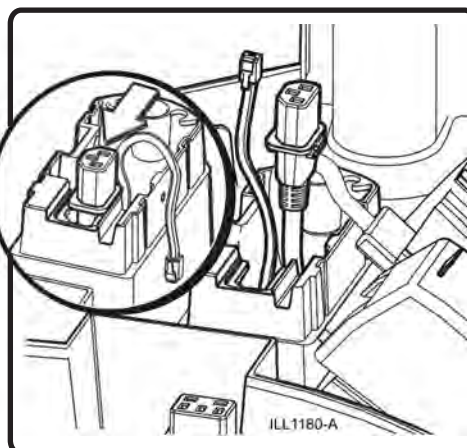
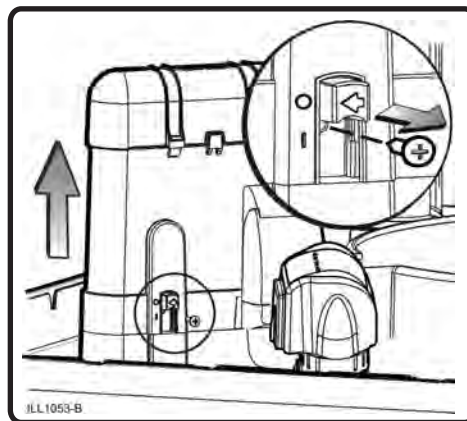

You have the choice of installing the Drain Valve and water management system supplied, or not. If not, you need to install the Bleed Funnel alternative. See later note

DRAIN VALVE ALTERNATIVE

The function of the drain valve is to reduce the salts and minerals in the air cooler. It also provides overflow and water drain features.

Assemble the drain valve into the Water Tank as shown - see diagram. Make sure the O-ring is fitted before putting the Drain Valve into the hole in the Water Tank. Screw the nut underneath tight **by hand!!**

Attach the drain Adaptor under the Drain Valve and attach a pipe to carry the water to a suitable drain point. **Do not allow water to run freely onto the roof - it will stain the roof!!** See Diagram.

The Water Sensor protects the pump and helps control water salinity.

Fit the Water Sensor as shown by clipping it to the Water Tank. See Diagram. Make sure the clip engages fully. Route the sensor cable through the cable supports in the Water Tank as shown. See diagram. It will be connected later.

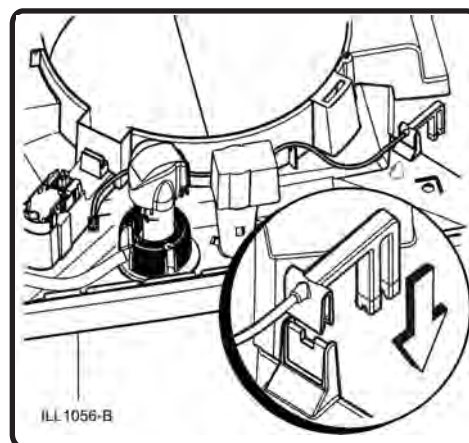
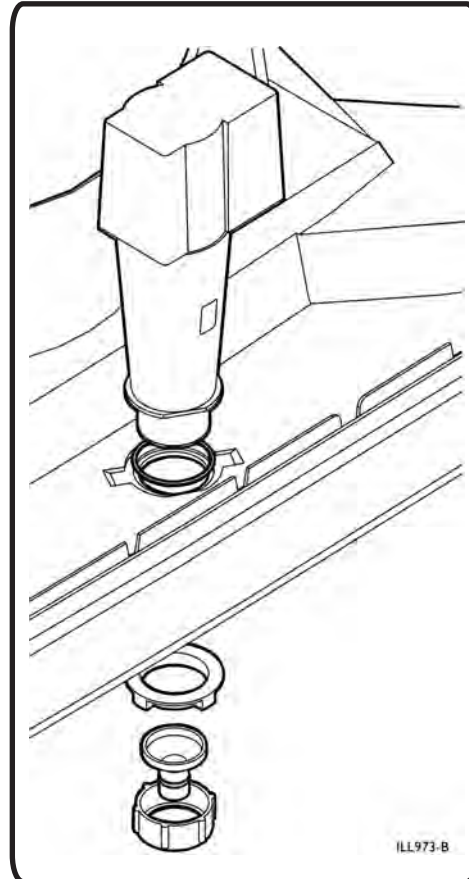

If you have installed the drain valve, then fit the float valve and solenoid valve to the air cooler as shown.

Make sure all washers and o-rings are fitted correctly. **Do not over-tighten plastic threads!!**

Make sure the Float Valve is centrally positioned and is free to move up and down.

Screw the Solenoid Valve into the extension tube. Check the direction of water flow with the arrow on the back of the valve . See diagram.

Make sure Solenoid Valve seals against the rubber washer on the Extension Tube. Twist the Solenoid Valve so that the cover will fit on OK.

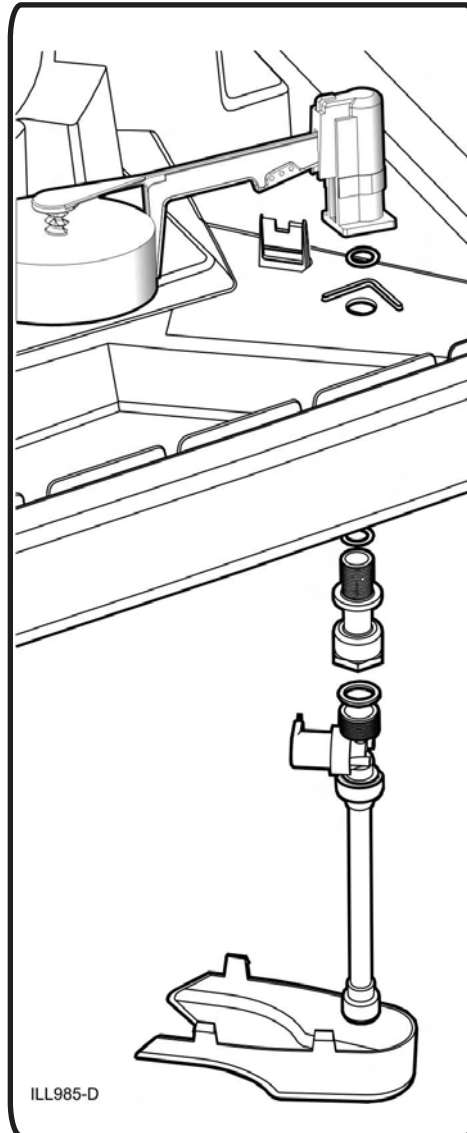

ILL985-D

Connect the solenoid cable (supplied in the kit) to the Solenoid Valve. Route the cable through the hole in the Transition. See diagram. The other end will be connected later.

IMPORTANT: Make sure the cable does not interfere with the Weatherseal and that it will not be crushed by the Venturi/fan assembly.

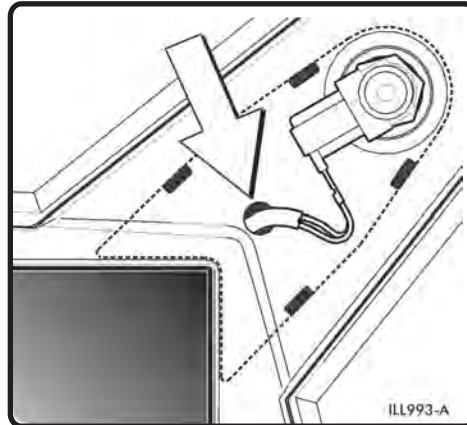

Clip the solenoid cover into place under the air cooler. Then screw the flexible water hose (supplied in the kit) onto the Solenoid Valve. Make sure the rubber washer seal is in place.

Important: take care when connecting the flexible water hose to the solenoid valve or the float valve adaptor. The threads may become crossed and the connection will fail.

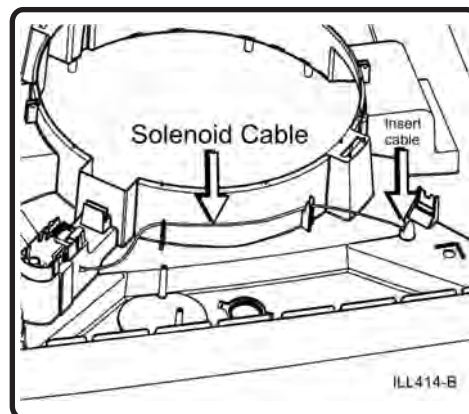

BLEED FUNNEL ALTERNATIVE

The bleed funnel is a simplified alternative to the drain valve. It also provides overflow and drain features.

Assemble the bleed funnel to the Water Tank as shown.

Make sure the o-rings are fitted correctly.

Screw the nut tight **by hand!!**

Attach the Drain adaptor under the Bleed Funnel and attach a pipe to carry the water to a suitable drain point. **Do not allow the water to run freely onto the roof - it will stain the roof!!**

The required rate of bleed will vary according to the water quality. Set it to the minimum rate, as shown in the following table.

TBA250	1 Plug in
TBA350	1 Plug in
TBA450	2 Plugs in
TBA550	2 Plugs in

If salt starts to build up on the Cooling Pads insert another plug. Adjust the bleed rate until the salt build up is minimised. The water management devices fitted will help control the effects of poor quality water, but they cannot eliminate the problem.

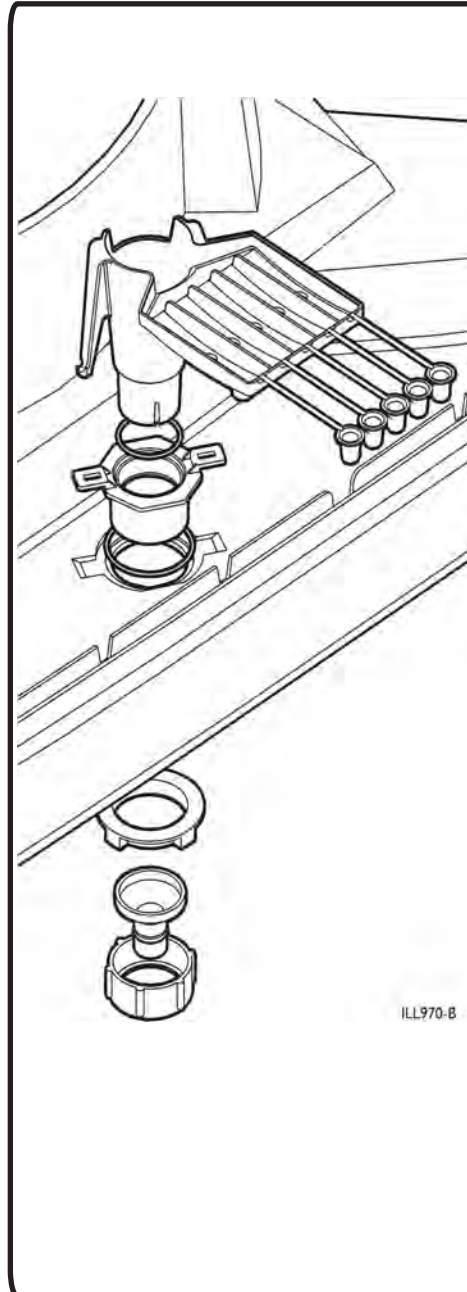

After fitting the Bleed Funnel, then fit the Float Valve as shown complete with the Extension tube and 3/4" to 1/2" adaptor. See diagram. Make sure that all washers and o-rings are fitted correctly. **Do not over-tighten plastic threads !!**

Make sure the float on the Float Valve is centrally positioned and is free to move up and down.

MAIN WATER CONNECTION

Connect the main water supply to the water inlet point under the air cooler.

Always install a shut-off valve (do not use a non return type valve) close by the air cooler. In areas where freezing might occur always install a drain-down point for the mains water supply.

The water connection is 1/2 inch BSP male thread.

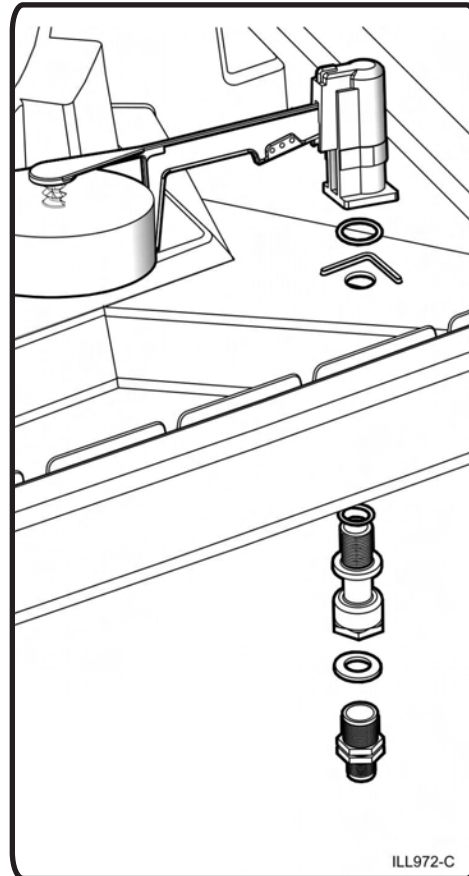

Now the Electronics Module must be re-fitted. First take the wall control cable and the Solenoid Valve cable (if installed) that are loose in the Water Tank and route them out from the Electronics Module location, as shown. The cables must rest in the special channel provided. See diagram. Leave about 200mm (8") of cable for later connection.

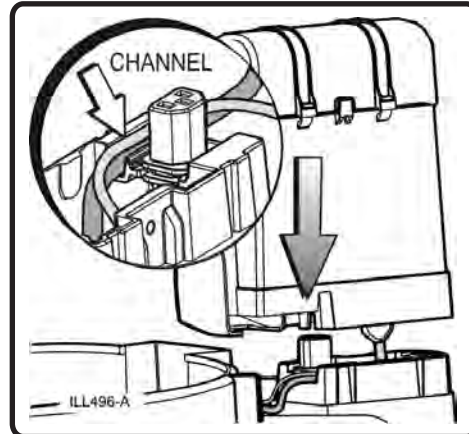

Connect the motor cable into the Electronics Module.

Fit the Electronics Module to its base in the Water Tank and screw it in place. See diagram.

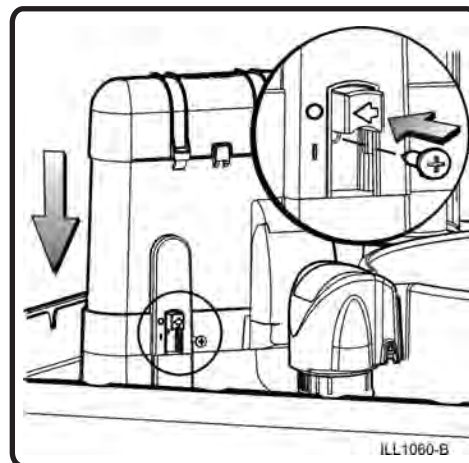

Lift the flexible cover on the Electronics Module. You will see some plug points. Connect the wall control cable to its correct plug point. If the drain valve, water sensor and solenoid valve are fitted then connect those cables also. Route the drain valve cable as shown before connecting it.

Do not connect the pump cable yet.

IMPORTANT: Ensure the cables are connected in the correct way as shown

Now turn on the isolation switch and replace the pad frames (except the front padframe to allow access).

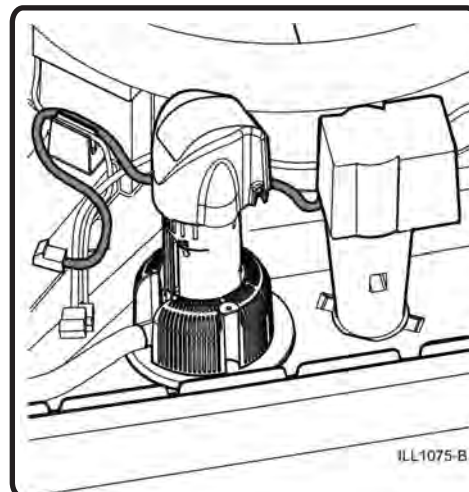
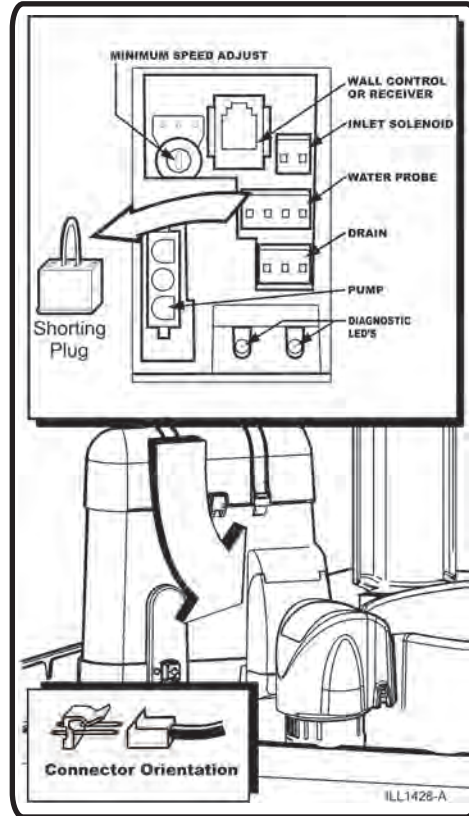

Carry the Venturi/Fan assembly to the air cooler and fit it back in place. It will only fit one way. Check that the two (2) clips are properly engaged.

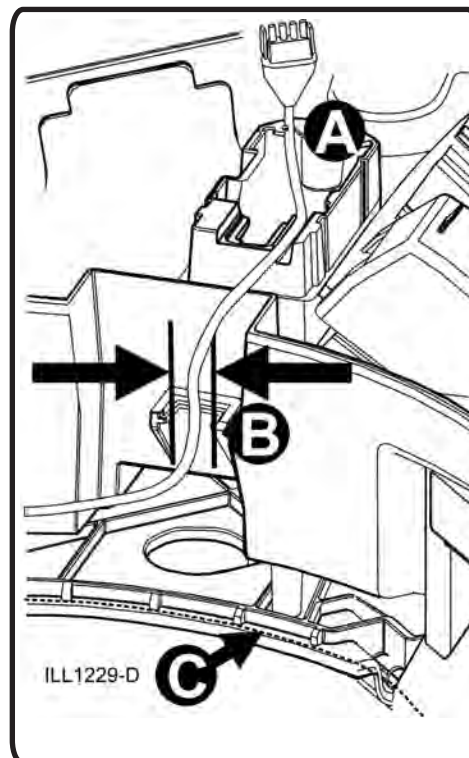
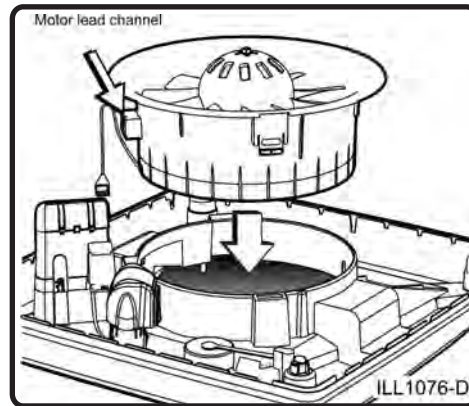

WALL CONTROL LOCATION

Install the Wall Control station about 1.5 metres above the floor in the place where you want the temperature to be controlled from.

When selecting a position for the Wall Control station avoid the following locations:

- Direct sunlight.
- Outside walls.
- Any heat sources.
- A position in direct line of a cooling outlet.

Mounting the wall control in a position near any heat source or cooling outlet will affect its ability to control temperature.

The Wall Control cable will plug into the back of the Control.

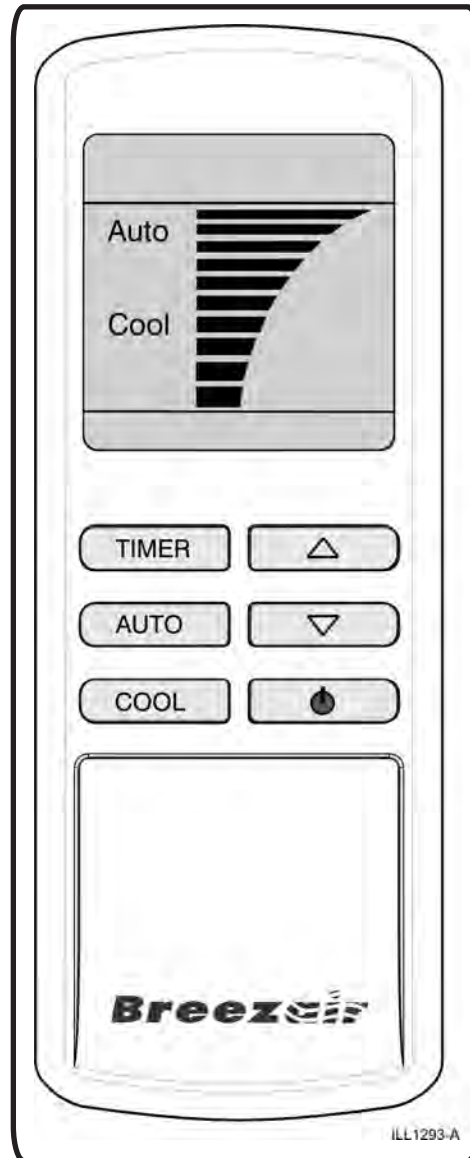

PLASTER BOARD OR BRICK WALL

To mount the wall control on a plaster board or brick wall, use the template provided and drill the 16mm hole for the wall control cable and the (5mm Plasterboard or 6mm Brick) holes for the mounting plugs.

Note: For brick walls, position the template so the screw and cable holes are not located into the mortar between the bricks.

WARNING: Ensure there are no electrical wires behind the wall where you intend to drill.

Insert the mounting plugs into the holes and ensure the plug face is against the wall.

Position the wall plate over the screw holes and secure the top screw. Align the wall plate vertically and secure with the lower screw.

Check alignment and tighten the screws.

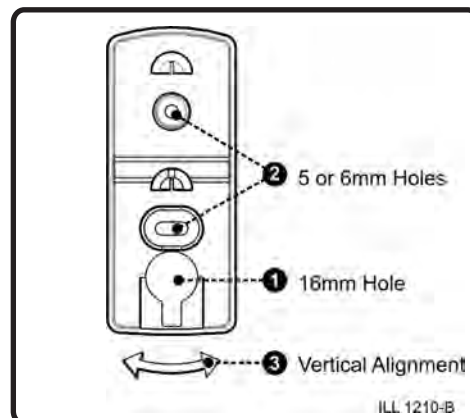
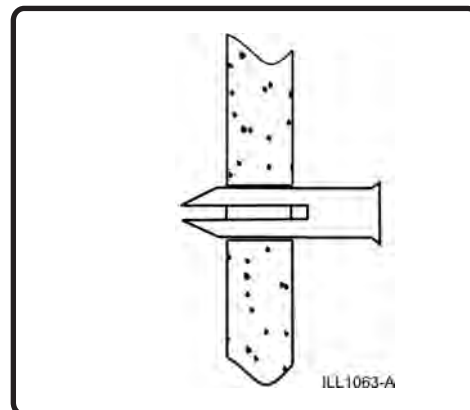
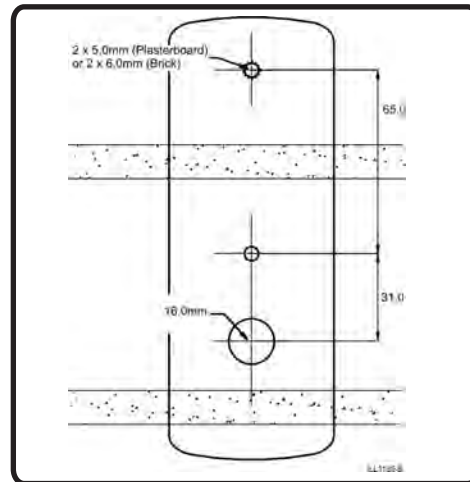

Pull the wall control cable through the large hole and wall plate, remove the protective tape and plug the cable into the wall control.

Feed the excess cable back into the hole and slide the wall control over the protruding bracket tabs. Pull the wall control down so the bracket tabs engage with the keyway slots on the back.

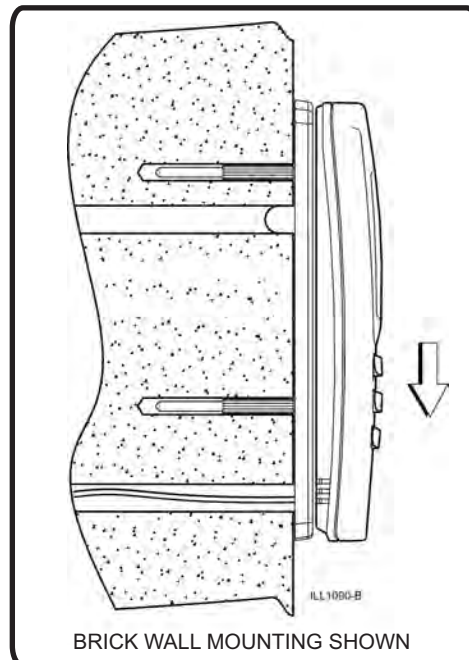
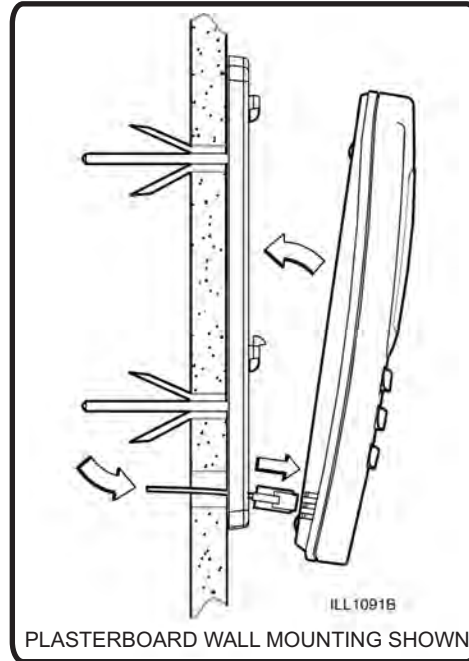

To enter the programming mode, the procedure must be started within four (4) minutes of power being applied to the wall control. If this time has elapsed then turn off power to the air cooler for a minimum of 6 seconds before starting the following procedure.

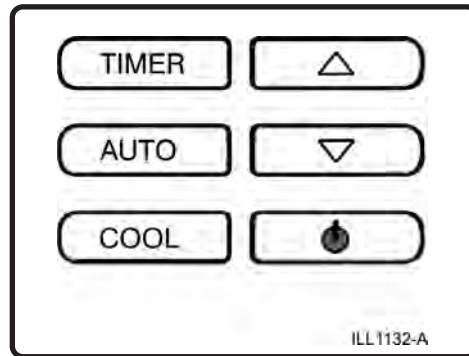

SET UP FOR BLEED FUNNEL

If you installed the bleed funnel instead of the drain valve then you will need to set the wall control and cooler for manual bleed operation.

1. While the wall control is OFF, hold down AUTO for at least 3 seconds.
 2. Press ▲ while still pressing AUTO.
 3. The setting "A1" will be displayed. Press ▲ until "A4" is displayed as shown.
 4. Press AUTO.
 5. A number will now be displayed. Press ▼ until "0" is displayed as shown.
 6. Press AUTO.
- Exit the programming mode by pressing the POWER button.

Abort an alteration by pressing the POWER button instead of AUTO.

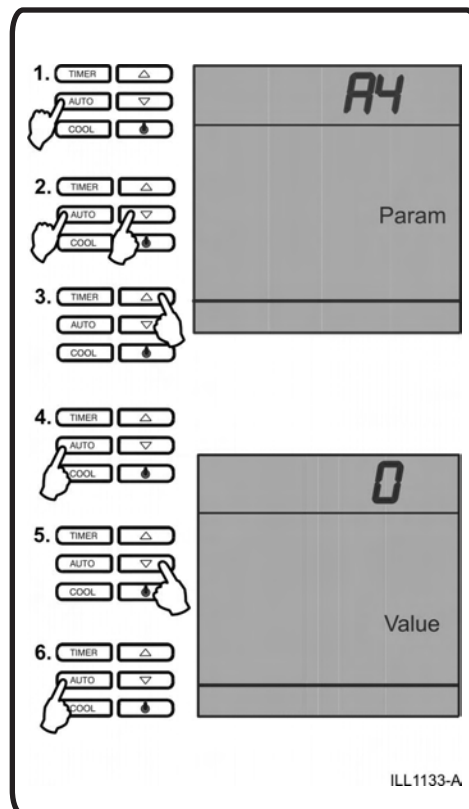

DRAIN RATE ADJUSTMENT

If you installed the drain valve then the water will drain when the sensor detects that the water salinity is too high. Alternatively and if necessary, the air cooler can be set to replace some water after a set time of cooling operation with the following procedure.

1. While the wall control is OFF, hold down AUTO for at least 3 seconds.
2. Press ▼ while pressing AUTO. "A1" displays.
3. Release Auto. Press ▲ until "A6" displays.
4. Press AUTO.
5. "00" will display. Press ▲ until "01" displays.
6. Press AUTO.
7. "A6" will display. Press ▲ until "A8" displays.
8. Press AUTO.
9. A number will be displayed. Press ▼ or ▲ until the number displayed corresponds to the desired drain delay time in the table below.

Display Number	Time between drains
05	1.3 hours
07 STANDARD	2 hours
11	4 hours
15	10 hours

10. Press AUTO to complete the adjustment. Exit the programming mode by pressing the POWER button.

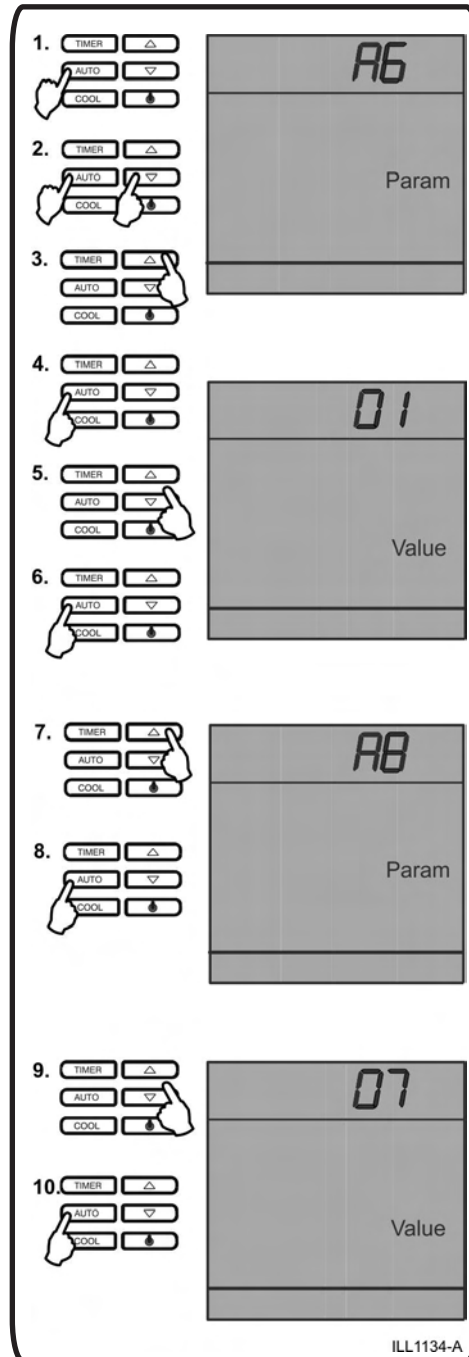

ILL1134-A

CORRECT WATER LEVEL

With the water pump still disconnected, turn on the water supply and allow the tank to fill. If you have installed the drain valve instead of the bleed funnel you will need to turn the water on by pressing COOL on the wall control while it is in the OFF state. The water inlet valve will now remain open for 15 minutes.

When the tank is full the float valve will stop the water entering the air cooler. Wait for this to happen and observe the level. The correct water level is approximately 5mm below the surface of the tank the float valve is mounted on. If the level is too high rotate the float clockwise. If it is too low rotate the float anti-clockwise, as shown.

If you installed the drain valve, a complete drain can be initiated by holding down both ▲ and ▼ for 1 second when the wall control is OFF. The signal "dr" will display to confirm the drain operation has activated.

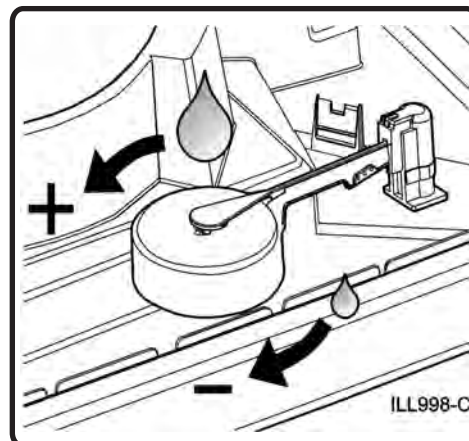
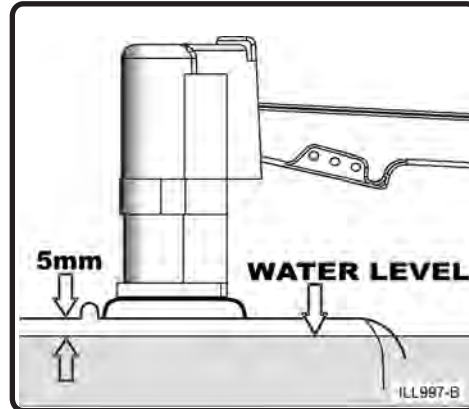

WATER PUMP CONNECTION

Switch off the electronics module. Route the pump cord as shown and connect the pump to the electronics module. Switch the electronics module on.

WARNING

Do not run the pump while the pad frames are off and the fan is on.

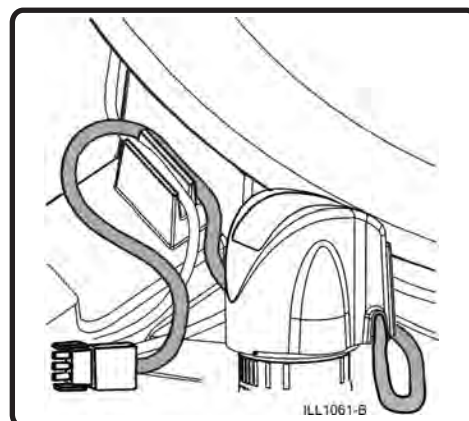

TEST OPERATION

Check that the green light on the electronics module is on. This indicates that power is connected to the electronics module. Make sure that the flexible cover on the electronics module is fully closed as shown.

Replace the pad frames and run the air cooler. To start the air cooler, press the power button on the wall control. If it has not been on before it will start in Manual control mode ("Man" will display as shown). The display will flash "Pre-Cool Cycle" as shown and the pump will soon operate to saturate the pads. This will take a few minutes and then the fan will start automatically.





Ensure the air cooler operates correctly and does not leak water. Make sure that the air flow from the outlets is balanced and that there are no air leaks in the ducting.

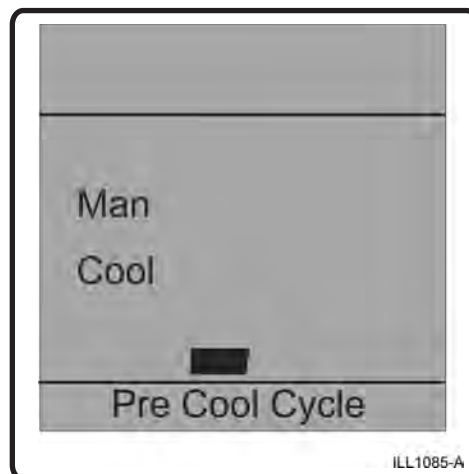
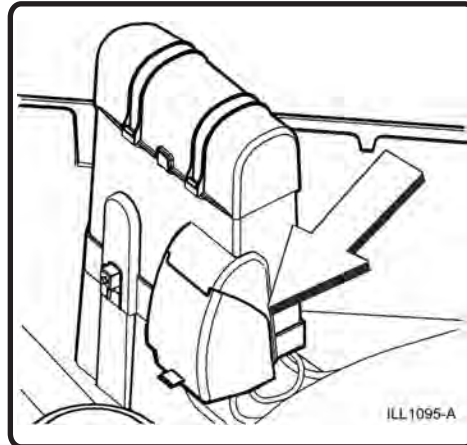

If you installed the drain valve, test that the drain valve opens by holding down both ▲ and ▼ for 1 second when the wall control is OFF. The signal "dr" will display to confirm the drain operation has activated.





Stop the air cooler and check that each of the pads are evenly saturated.

Finally, instruct the owner on how to operate the new air cooler.







PROBLEM - Inadequate Cooling	
CAUSE	ACTION
1. Pump not working correctly	 Check plug, wiring and circuit breaker. Impellor may be jammed or obstructed. Check salinity sensor correctly installed Rectify fault or replace pump.
2. Dry pads.	 Check water flow to pads. Inspect fitment of distributor cap. Check for blocked or kinked hose. If blocked, dismantle, clean and flush or unkink the hose.
3. Leaking ducts	 Find leaks and seal.
4. Weatherseal failing to open.	 Break off transport clips. Check for weatherseal/transition screw interference. Check minimum fan speed setting



PROBLEM - Motor starts and stops at intervals	
CAUSE	ACTION
1. Loose electrical connections.	 Check all electrical connections.
2. Fan not turning freely.	 Determine cause and rectify.
3. Weatherseal failing to open.	 Break off transport clips. Check for weatherseal/transition screw interference. Check minimum fan speed setting.









PROBLEM - Continually leaking water when turned off	
CAUSE	ACTION
1. Dirt under drain valve seal.	 Clean and refit seal, clean any remaining debris from tank.
2. Dirt under float valve seal.	 Clean and refit seal.
3. Water level set too high.	 Set water level as described in the "Commissioning Cooler" section.
4. Water pressure too high.	 Install pressure reducing valve

PROBLEM - Unpleasant Odour	
CAUSE	ACTION
1. Odour from new pads.	 Allow time to condition by running the air cooler

PROBLEM - No Variable Speed.	
CAUSE	ACTION
1. Faulty electronics module or wall control	 Replace electronics module or wall control
2. Minimum fan speed set too high.	 Adjust fan speed. See diagram on pg 16.

PROBLEM - Noisy Unit	
CAUSE	ACTION
1. Resistance in the ducting system	 Check that sufficient outlets are provided and are open.
2. Insufficient exhaust openings for conditioned air.	 Refer to minimum exhaust opening requirements for the particular cooler models as shown in the table in the Owners Manual.
3. Fan is hitting the venturi.	 Check that the venturi is installed correctly.

PROBLEM - No Water Drain Function (Drain Valve only).	
CAUSE	ACTION
1. Drain valve failure.	 Replace drain valve.
2. Drain valve incorrectly connected	 Check plug connection and orientation. See diagram on pg 16.
3. Water sensor not operating.	 Check sensor. Clean sensor.

PROBLEM - Unit Will Not Run / Wall Control Display Fault	
CAUSE	ACTION
1. No power to unit.	 Check GPO switch and fuse or circuit breaker. Check isolation switch, power cord plug and circuit breaker on the electronics module. Check venturi assembled correctly to plug.
2. No power to wall control (No display or backlighting.)	 Check for wall control cable unplugged, faulty cable, or faulty wall control. Replace faulty parts as necessary.
3. No signal to electronics module (wall control display appears correct, red light on electronics module flashes)	 Check for damaged or faulty wall control cable.
4. Wall control and electronics module not compatible. (wall control displays "service").	 Reset the wall control - press and hold  for 6 seconds until "service" disappears on the display
5. Mains supply frequency change. (Wall control displays "service", red light on electronics module flashes)	 Reset the wall control by pushing the power button.
6. Water sensor not working (if water sensor installed.)(wall control displays "service", red light on electronics module flashes)	 Check that the sensor is correctly fitted and the cable is plugged in. Clean sensor probes and remove all debris as necessary.
7. Insufficient water pressure to raise the water level to the sensor within 8 minutes. (if water sensor installed.) (Wall control displays "service" after 8 minutes, red light on electronics module flashes)	 Check that the water pressure is sufficient to fill the tank to the sensor within 8 minutes.
8. Drain valve remains open so water does not reach sensor within 8 minutes. (if drain valve installed.) (Wall control displays service" after 8 minutes, red light on electronics module flashes)	 Check that the drain valve is closed when the unit fills. Clean debris from the drain valve. Check the drain valve cable is connected and the plug is oriented correctly - see diagram on page 16.

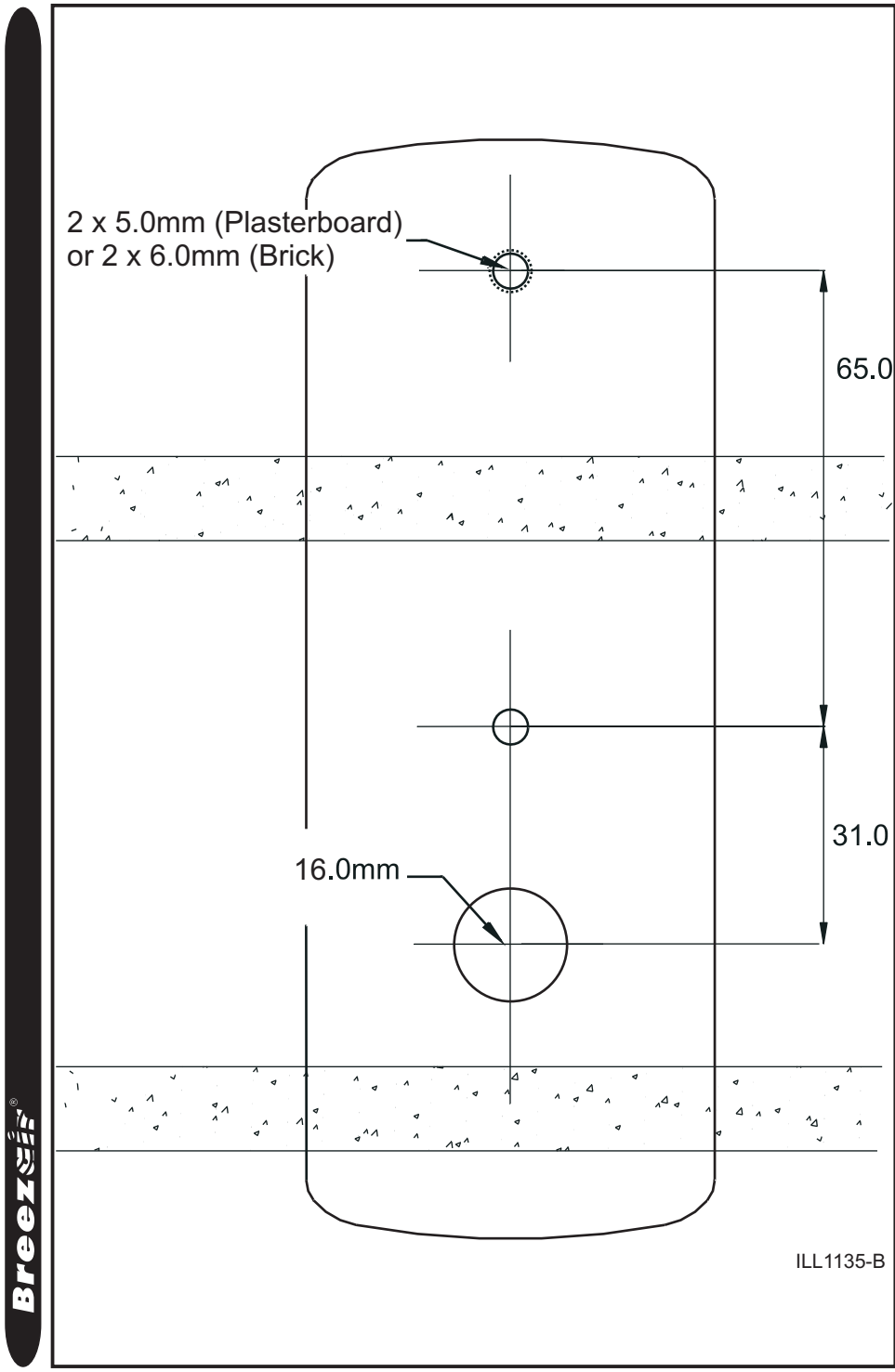



Evaporative Air Cooling Manual. Seeley International Pty Ltd, Adelaide, South Australia. ACN 054 687 035.

As the policy of the company is one of continuous product improvement, all specifications are subject to change without notice.