

This Owner's Manual is provided and hosted by [Appliance Factory Parts](#).

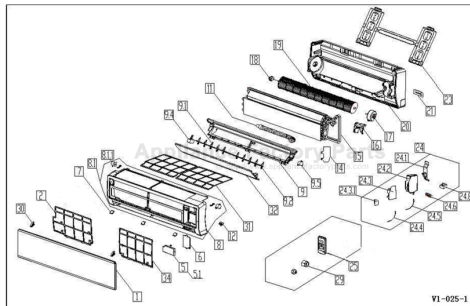

COMFORT-AIRE B-VMH09FC-1 Owner's Manual

[Shop genuine replacement parts for COMFORT-AIRE
B-VMH09FC-1](#)



[Find Your COMFORT-AIRE HVAC Parts - Select From 1486 Models](#)

----- Manual continues below -----

Comfort-Caire®

Century®

MARS
Delivering Confidence

REPLACEMENT PARTS LIST

InverterFlex Series®
Multizone Inverter Heat Pump
Ductless Mini-Split
B-VMH09FC-1
Indoor Evaporator

EXPLODED VIEW

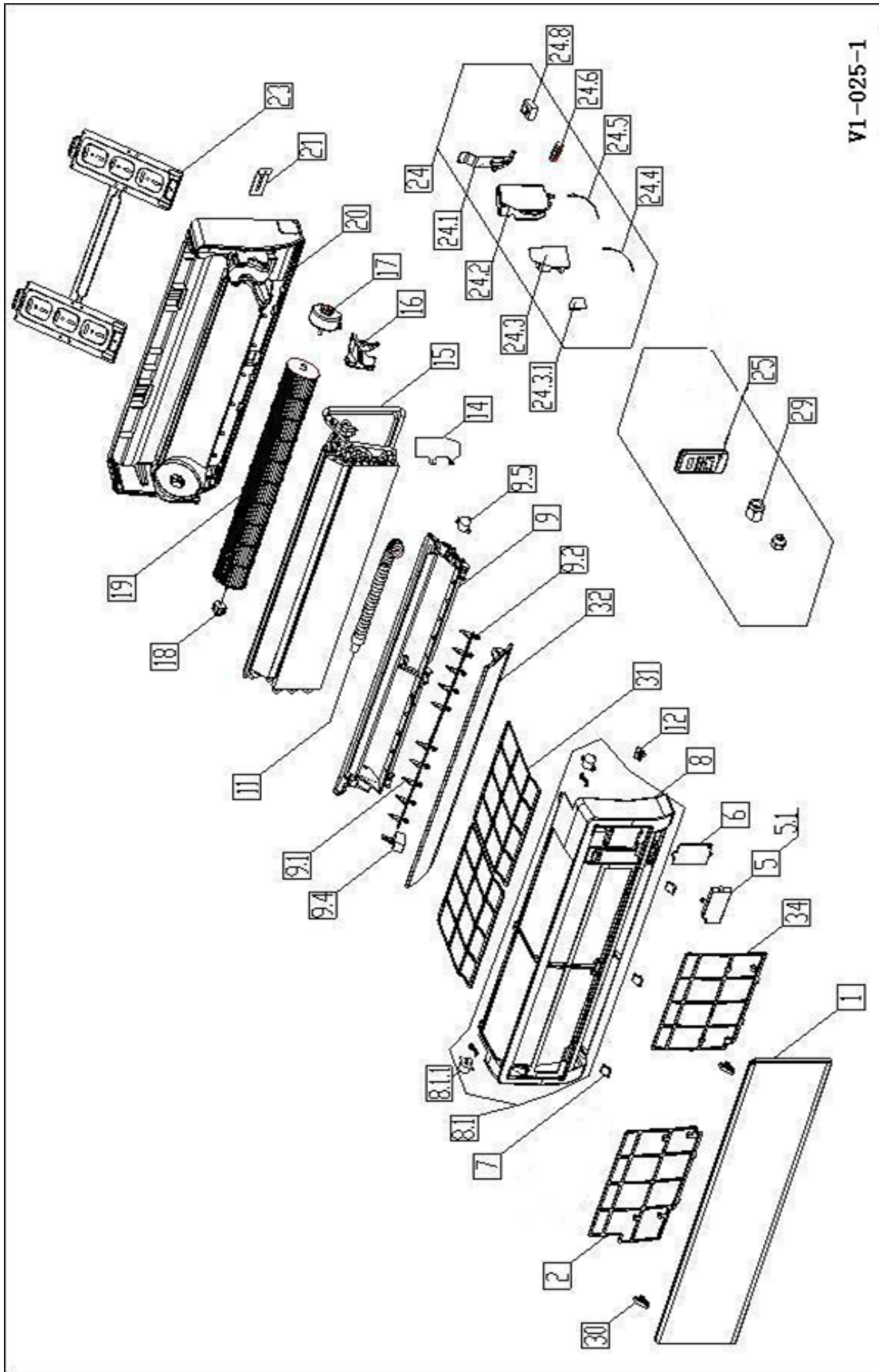

REPLACEMENT PARTS

Location	Part Name	Quantity	Part No.
1	Panel assembly	1	2011323A2036
2	Air filter(left)	1	201132300002
5	Display box assembly	1	203332590183
5.1	Display board assembly	1	201332590462
6	Cover of indoor electronic control box	1	201132500012
7	Screw cap	3	201132300037
8	Panel frame assembly	1	201132300895
8.1	Panel frame assembly	1	201132300026
8.1.1	Louver motor	1	202400200105
9	Air outlet assembly (w/evap. pan)	1	201132390014
9.1	Vertical vane	10	201132590031
9.2	Louver holder	1	201132500032
9.2	Louver holder	1	201132500031
9.4	Ionizer generator	1	202403000006
9.5	Louver motor	1	202400200017
11	Drain hose	1	201101020038
12	Baffle of temperature sensor	1	201130490002
14	Waterproof board	1	201132500002
15	Evaporator assembly	1	201532390167
16	Fan motor cover	1	201132500017
17	Asynchronous motor	1	202400300137
18	Bearing base	1	202730100201
19	Cross flow fan	1	201100200100
20	Chassis assembly	1	201132300974
21	Pipe clamp board	1	201232500001
23	Installation plate	1	201232590025
24	Electronic control box assembly	1	203352090128
24.1	Cover of electronic control box	1	201132500021
24.2	Electronic control box	1	201132500022
24.3	Main control board assembly	1	17122300000149
24.3.1	Fan motor capacitor	1	202401200001
24.4	Indoor temperature sensor assembly	1	202433190000
24.5	Pipe temperature sensor assembly	1	202301300080
24.6	Wire joint (Terminal Strip)	1	202301420101
24.8	Transformer	1	202300900097
25	Remote Controller	1	203355091200
29	Nut	1	201600320001
29	Nut	1	201600320000
30	Hinge Slide groove	2	201132300005
31	Air inlet grille assembly (Top Filter)	1	201132300027
32	Horizontal louver	1	201132300033
34	Air filter(right)	1	201132300001

Due to ongoing product improvements, specifications and dimensions are subject to change and correction without notice or incurring obligations. Determining the application and suitability for use of any product is the responsibility of the installer. Additionally, the installer is responsible for verifying dimensional data on the actual product prior to beginning any installation preparations.

Incentive and rebate programs have precise requirements as to product performance and certification. All products meet applicable regulations in effect on date of manufacture; however, certifications are not necessarily granted for the life of a product. Therefore, it is the responsibility of the applicant to determine whether a specific model qualifies for these incentive/rebate programs.

Comfort-Cire®  **Century**®

1900 Wellworth Ave., Jackson, MI 49203 • Ph. 517-787-2100 • www.marsdelivers.com

