Comfort-Aire®

Century®

MARS
Delivering Confidence

REPLACEMENT PARTS LIST

InverterFlex Series®
Indoor Ductless Mini-Split
B-VFH09MA-1
Heat Pumps

EXPLODED VIEW

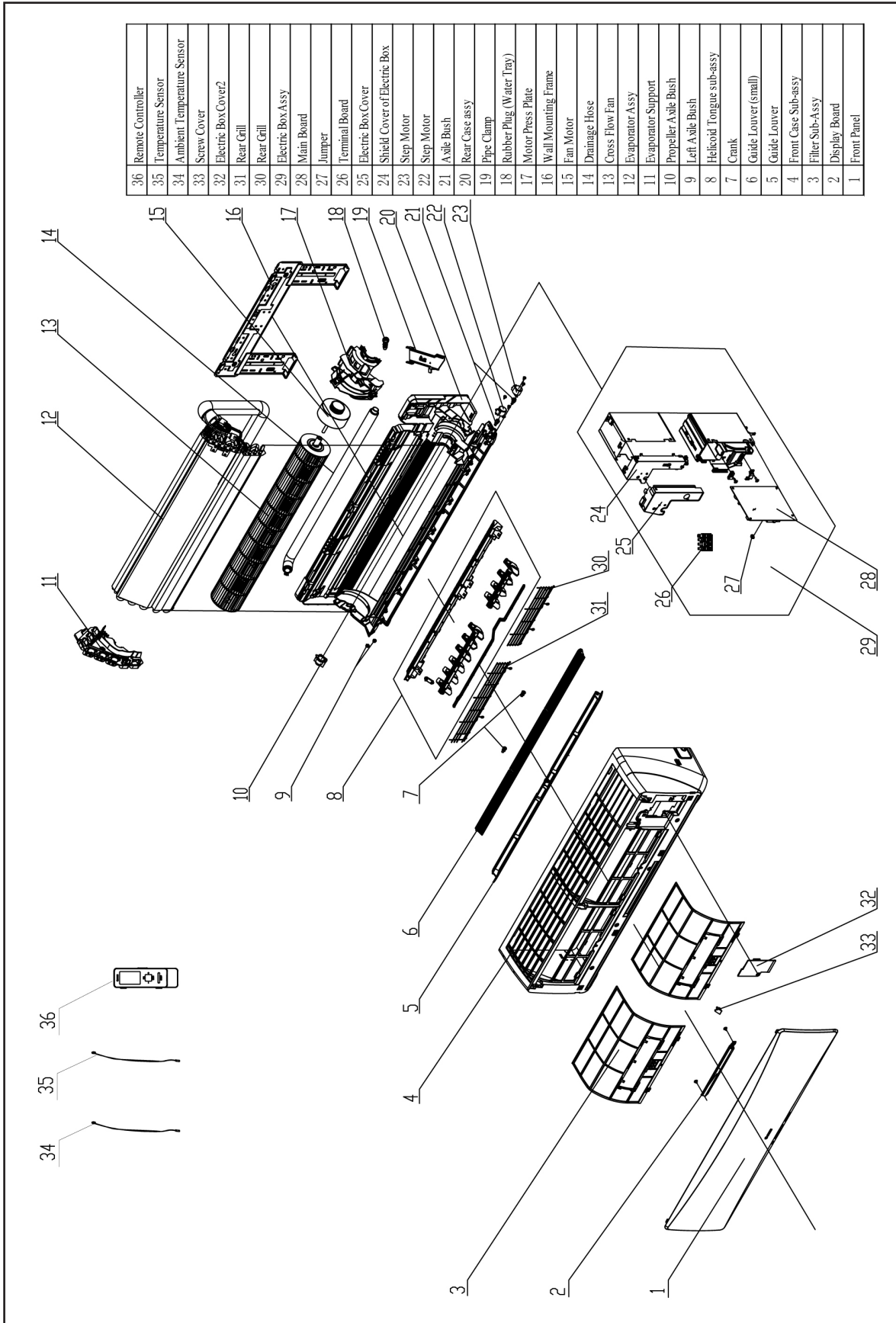

36	Remote Controller
35	Temperature Sensor
34	Ambient Temperature Sensor
33	Screw Cover
32	Electric Box Cover2
31	Rear Grill
30	Rear Grill
29	Electric Box Assy
28	Main Board
27	Jumper
26	Terminal Board
25	Electric Box Cover
24	Shield Cover of Electric Box
23	Step Motor
22	Step Motor
21	Axle Bush
20	Rear Case assy
19	Pipe Clamp
18	Rubber Plug (Water Tray)
17	Motor Press Plate
16	Wall Mounting Frame
15	Fan Motor
14	Drainage Hose
13	Cross Flow Fan
12	Evaporator Assy
11	Evaporator Support
10	Propeller Axle Bush
9	Left Axle Bush
8	Helicoid Tongue sub-assy
7	Crank
6	Guide Louver (small)
5	Guide Louver
4	Front Case Sub-assy
3	Filter Sub-Assy
2	Display Board
1	Front Panel

REPLACEMENT PARTS

Location	Part Name	Quantity	Part No.
1	Front Panel	1	27230002022
2	Display Board	1	30565203
3	Filter Sub-Assy	2	1112211602
4	Front Case Sub-assy	1	2001288903
5	Guide Louver	1	1051226701
6	Guide Louver (small)	1	10512127
7	Crank	1	10582070
8	Helicoid Tongue sub-assy	1	2611224404
9	Left Axile Bush	2	10512037
10	Propeller Axile Bush	1	1054202101
11	Evaporator Support	1	24212114
12	Evaporator Assy	1	01002364_L08294
13	Cross Flow Fan	1	10352033
14	Drainage Hose	1	05230014
15	Fan Motor	1	15013314
16	Wall Mounting Frame	1	01252484
17	Motor Press Plate	1	26112209
18	Rubber Plug (Water Tray)	1	76712012
19	Connecting pipe clamp	1	2611216402
20	Rear Case assy	1	2220216103
21	Axile Bush	2	10542036
22	SteppingMotor	1	15212126
23	SteppingMotor	1	15212125
24	Shield Cover of Electric Box	1	01592084
25	Electric Box Cover	1	2012240901
26	Terminal Board	1	42011233
27	Jumper	1	4202300107
28	Main Board	1	30148296
29	Electric Box Assy	1	2030249201
30	Rear Grill	1	01472030
31	Rear Grill	1	01472029
32	Electric Box Cover2	1	2012207507
33	Screw Cover	1	242520179
34	Temperature Sensor	1	390000451
35	Temperature Sensor	1	390000598
36	Remote Controller	1	30510138L08294
-	Remote Control Holder	1	26150008

Due to ongoing product improvements, specifications and dimensions are subject to change and correction without notice or incurring obligations. Determining the application and suitability for use of any product is the responsibility of the installer. Additionally, the installer is responsible for verifying dimensional data on the actual product prior to beginning any installation preparations.

Incentive and rebate programs have precise requirements as to product performance and certification. All products meet applicable regulations in effect on date of manufacture; however, certifications are not necessarily granted for the life of a product. Therefore, it is the responsibility of the applicant to determine whether a specific model qualifies for these incentive/rebate programs.

Comfort-Cire[®]  **Century**[®]

1900 Wellworth Ave., Jackson, MI 49203 • Ph. 517-787-2100 • www.marsdelivers.com

