

This Owner's Manual is provided and hosted by [Appliance Factory Parts](#).



COMFORT-AIRE RG-51M Owner's Manual

[Shop genuine replacement parts for COMFORT-AIRE
RG-51M](#)



[Find Your COMFORT-AIRE Air Conditioner Parts - Select From 599 Models](#)

----- Manual continues below -----



PARTS LIST

Room Air Conditioner with R-410A

RG-51M

EXPLODED VIEW

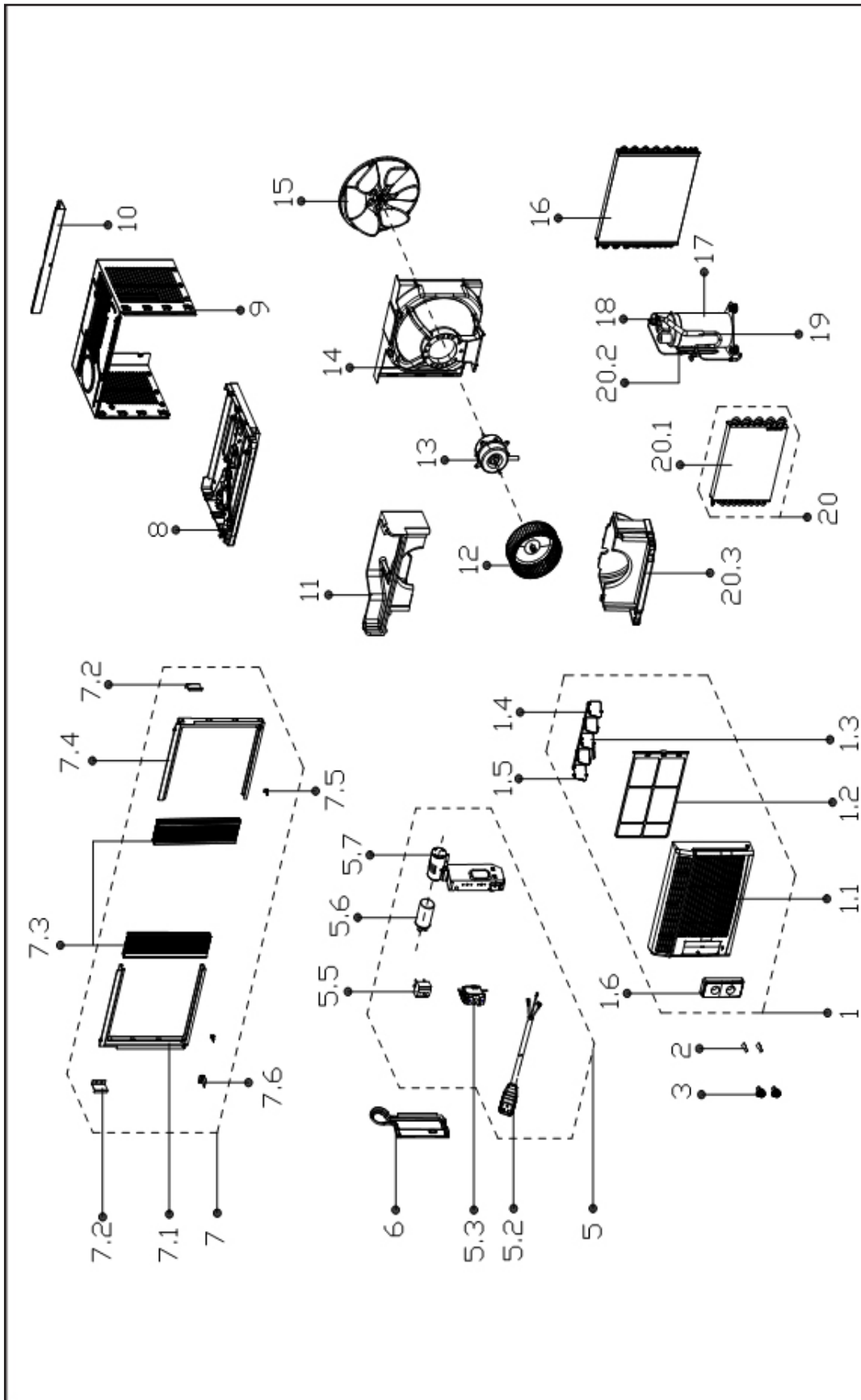

REPLACEMENT PARTS

Location	Part Name	Quantity	Part No.
1	Panel assembly	1.0	12120300A01735
1.1	Panel	1.0	12120300A00702
1.2	Filter	1.0	12100204000700
1.3	Louver	1.0	12120300A00588
1.4	Louver Holder	1.0	12120300000966
1.5	Louver	4.0	12120300A00593
1.6	Control box	1.0	12120300A00540
2	Knob spring piece	2.0	12900102000013
3	Knob	2.0	12100403000053
5	E-Parts Box Assembly of Upper Air-out Window Series - E-Parts Box Assembly	1.0	17220300000290
5.2	Power Supply Cable Subassembly	1.0	17401202000045
5.3	Temperature controller	1.0	17400513000013
5.5	Main switch	1.0	17400517000009
5.6	Combined Capacitor	1.0	17400104000015
5.7	Structure Subassembly of Electrical Control Box	1.0	12220300000509
6	Electrical Control Box Cover	1.0	12220300000485
7	Installing Accessories	1.0	12020300000041
7.5	Shutter Clamp	2.0	12220300000878
7.6	Installing L Plate	1.0	12220300000863
8	Chassis Assembly	1.0	12220300000435
9	Cabinet Assembly	1.0	12220300000146
10	Upper Shutter Frame Assembly	1.0	12220300000917
11	Upper Air Duct Foam Subassembly	1.0	12820300000111
12	Centrifugal Fan	1.0	12100103000062
13	Single-phase Asynchronous Motor	1.0	11002012005410
14	Rear barrier Subassembly	1.0	12120300000564
15	Axial fan	1.0	12100105000021
16	Condenser Assembly	1.0	15820300000552
17	Fixed speed rotary compressor	1.0	11103010000015
18	Parts of compressor exhaust pipe	1.0	15120300001049
19	Compressor suction pipe	1.0	15120300000477
20	Evaporator assembly Gas valve assembly	1.0	15820300000177
20.1	Evaporator	1.0	15820300000410
20.2	Capillary Assembly	1.0	15120300001267
20.3	Lower Air Duct Foam Subassembly Subassembly	1.0	12820300000123
Not Shown	Control box label	1.0	16020300A00045

Due to ongoing product improvements, specifications and dimensions are subject to change and correction without notice or incurring obligations. Determining the application and suitability for use of any product is the responsibility of the installer. Additionally, the installer is responsible for verifying dimensional data on the actual product prior to beginning any installation preparations.

Incentive and rebate programs have precise requirements as to product performance and certification. All products meet applicable regulations in effect on date of manufacture; however, certifications are not necessarily granted for the life of a product. Therefore, it is the responsibility of the applicant to determine whether a specific model qualifies for these incentive/rebate programs.

Comfort-Cire[®]

1900 Wellworth Ave., Jackson, MI 49203 • Ph. 517-787-2100 • www.marsdelivers.com

