

This Owner's Manual is provided and hosted by [Appliance Factory Parts](#).



COMFORT-AIRE GLUA90E-4B Owner's Manual

[Shop genuine replacement parts for COMFORT-AIRE
GLUA90E-4B](#)



[Find Your COMFORT-AIRE HVAC Parts - Select From 1487 Models](#)

----- Manual continues below part list -----

Available Replacement Parts for COMFORT-AIRE GLUA90E-4B

68-24048-01	TRAP, CONDENSATE
70-24041-01	WHEEL, BLOWER
68-23473-01	PVC VANE

GLUA

Parts List
07-January-2008



This parts list is current as of the above revision date.

Form Number: 92-42810-GLUA

Table of Contents

Model Explanation	Page 3
Parts Numbers	
Panels - Miscellaneous 04-07	Page 4
Panels - Miscellaneous 07-12	Page 5
Electrical Group	Page 6
Blower Group	Page 7
Heat Exchanger-Burner Group	Page 8
Gas Controls	Page 9
Orifice Selection Chart	Page 10
Drawings/Photographs	
Exploded View	Page 11
Drain Trap Parts	Page 12
Blower Assembly	Page 12
Burner Assembly	Page 13
Notes	Page 14

MODEL NUMBER EXPLANATION

G	L	U	A	-	5	0	E	3	A
1	2	3	4			5		6	7

- (1) **GAS**
- (2) **90% EFFICIENCY**
- (3) **UPFLOW/HORIZONTAL CONDENSING**
- (4) **PLACEHOLDER**
- (5) **HEATING INPUT DESIGNATION**
 40 = 45,000 BTU/HR
 60 = 60,000 BTU/HR
 75 = 75,000 BTU/HR
 90 = 90,000 BTU/HR
 105 = 105,000 BTU/HR
 120 = 120,000 BTU/HR
 E = Electric
 N = NOX
- (6) **DRIVE NOMINAL COOLING/REVISION LEVEL**
 3 = 3 Ton
 4 = 4 Ton
 5 = 5 Ton
- (7) **REVISION LEVEL**

SERIAL NUMBER EXPLANATION

G	Y	5	D	7	0	2	F	3	1	0	7	9	9	9	9
1	2	3	4	5	6	7	8	9	10						

- 1 GAS CODE**
- 2 LIMIT CONTROL**
- 3 BLOWER**
- 4 HEATING ELEMENT**
- 5 SPECIAL AREA REQUIREMENT**
- 6 MOTOR HORSEPOWER**
- 7 PLANT**
- 8 WEEK**
- 9 YEAR**
- 10 PRODUCTION NUMBER**

No.	Notes	MODEL HEATING INPUT VARIATIONS	GLUA 45E 3B	GLUA 60E 3B	GLUA 75E 3B	GLUA 75E 4B
PANELS, SHEET METAL, MISCELLANEOUS						
1		Blower/Filter Door	AS-67890-11	AS-67890-11	AS-67890-11	AS-67891-11
2		Burner Compartment Door	AS-61866-09	AS-61866-09	AS-61866-09	AS-61867-09
		Sight Glass	68-21893-03	68-21893-03	68-21893-03	68-21893-03
3		Pressure Switch	See Electrical Group			
4		Silicone Tubing (Pressure Switch)	AE-61737-23	AE-61737-23	AE-61737-23	AE-61737-23
5		Trap/Elbow Assembly	68-24048-01	68-24048-01	68-24048-01	68-24048-01
6		Hose Clamps (6)	64-22043-02	64-22043-02	64-22043-02	64-22043-02
7		Water Trap Mount Bracket	AE-61841-01	AE-61841-01	AE-61841-01	AE-61841-01
8		Tubing	79-25353-82	79-25353-82	79-25353-82	79-25353-82
9		Induced Draft Blower w/Gasket	See Electrical Group			
10		Gasket - Induced Draft Blower	68-24016-01	68-24016-01	68-24016-01	68-24016-01
11		Silicone Tubing (Pressure Switch)	AE-61737-02	AE-61737-02	AE-61737-02	AE-61737-02
12		Pressure Switch	See Electrical Group			
13		Blower Assembly	See Blower Group			
14		Door Switch - Push Button	See Electrical Group			
15		Junction Box	AE-61475-02	AE-61475-02	AE-61475-02	AE-61475-02
16		Junction Box Cover	AE-61476-02	AE-61476-02	AE-61476-02	AE-61476-02
		Wiring Harnesses	See Electrical Group			
21		Button Plug (2-1/2 in.)	45-22980-03	45-22980-03	45-22980-03	45-22980-03
22		Button Plug (2 in.)	45-22980-08	45-22980-08	45-22980-08	45-22980-08
23		Jacket	AS-61820-04	AS-61820-04	AS-61820-04	AS-61820-06
24		Baffle	AE-61876-02	AE-61875-02	AE-61875-02	AE-61876-02
25		Rear Baffle	AE-61878-01	AE-61878-01	AE-61878-01	AE-61878-02
26		Baffle	AE-61886-01	AE-61875-01	AE-61875-01	AE-61876-01
30		Outlet Air Pipe	68-24021-01	68-24021-01	68-24021-01	68-24021-01
31		Outlet Air Pipe Gasket	68-24022-02	68-24022-02	68-24022-02	68-24022-02
32		Top Plate	AS-61872-01	AS-61872-01	AS-61872-01	AS-61872-02
33		Vinyl Grommet - 2 in.	56-22114-06	56-22114-06	56-22114-06	56-22114-06
34		Heat Exchanger Assembly	See Heat Exchanger Group			
35		Limit - Main Limit (Heat Exchanger Panel)	See Heat Exchanger Group			
37		Connector/Transition	68-24047-07	68-24047-07	68-24047-07	68-24047-08
38		Elbow	68-24013-01	68-24013-01	68-24013-01	68-24013-01
39		Tubing	79-25353-82	79-25353-82	79-25353-82	79-25353-82
44		Capacitor - Blower Motor	See Blower Group			
45		Capacitor - Induced Draft Blower	See Electrical Group			
46		Control Mounting Plate	AE-67877-01	AE-67877-01	AE-67877-01	AE-67877-01
47		Integrated Furnace Control Board (IFC)	See Gas Controls			
48		Transformer	See Electrical Group			
57		Gas Valve	See Gas Controls			
59		Ignitor Bracket	See Gas Controls			
60		Ignitor	See Gas Controls			

No.	Notes	MODEL HEATING INPUT VARIATIONS	GLUA ALL ALL			
PARTS BAG						
		Complete Parts Bag	AS-100717-01			
27		Locknut - Fresh Air Damper	64-24031-01			
28		Male Adapter	68-24028-01			
29		O-Ring Gasket	68-24032-01			
		1/2 in. PVC Pipe - 4 in.	68-22024-04			
		1/2 in. Tee	68-21980-02			
		Hose Clamp	64-22043-01			
		Hose Clamp (2)	64-22043-02			
		Plug - Nylon 7/8 in. (2)	45-22926-01			
		Plug - Nylon 1-1/8 in.	45-22926-02			
		PVC Vane	68-23473-01			
		PVC Wind Vane	68-24049-01			
		Grommet - Blower Shelf (5/8 in. ID) - Not included in Parts Bag	56-22521-03			
		Grommet - Blower Shelf (1/2 in. ID) - Not included in Parts Bag	56-24008-01			

No.	Notes	MODEL HEATING INPUT VARIATIONS	GLUA 90E 4B	GLUA 90E 5B	GLUA 105E 5B	GLUA 120E 5B
PANELS, SHEET METAL, MISCELLANEOUS						
1		Blower/Filter Door	AS-67891-11	AS-67891-11	AS-67891-11	AS-67892-11
2		Burner Compartment Door	AS-61867-09	AS-61867-09	AS-61867-09	AS-61868-09
		Sight Glass	68-21893-03	68-21893-03	68-21893-03	68-21893-03
3		Pressure Switch	See Electrical Group			
4		Silicone Tubing (Pressure Switch)	AE-61737-23	AE-61737-23	AE-61737-23	AE-61737-23
5		Trap/Elbow Assembly	68-24048-01	68-24048-01	68-24048-01	68-24048-01
6		Hose Clamps (6)	64-22043-02	64-22043-02	64-22043-02	64-22043-02
7		Water Trap Mount Bracket	AE-61841-01	AE-61841-01	AE-61841-01	AE-61841-01
8		Tubing	79-25353-82	79-25353-82	79-25353-82	79-25353-82
9		Induced Draft Blower w/Gasket	See Electrical Group			
10		Gasket - Induced Draft Blower	68-24016-01	68-24016-01	68-24016-01	68-24016-01
11		Silicone Tubing (Pressure Switch)	AE-61737-02	AE-61737-02	AE-61737-02	AE-61737-02
12		Pressure Switch	See Electrical Group			
13		Blower Assembly	See Blower Group			
14		Door Switch - Push Button	See Electrical Group			
15		Junction Box	AE-61475-02	AE-61475-02	AE-61475-02	AE-61475-02
16		Junction Box Cover	AE-61476-02	AE-61476-02	AE-61476-02	AE-61476-02
		Wiring Harnesses	See Electrical Group			
21		Button Plug (2-1/2 in.)	45-22980-03	45-22980-03	45-22980-03	45-22980-03
22		Button Plug (2 in.)	45-22980-08	45-22980-08	45-22980-08	45-22980-08
23		Jacket	AS-61820-05	AS-61820-05	AS-61820-05	AS-61820-07
24		Baffle	AE-61875-02	AE-61875-02	AE-61875-02	AE-61875-02
25		Rear Baffle	AE-61878-02	AE-61878-02	AE-61878-02	AE-61878-03
26		Baffle	AE-61875-01	AE-61875-01	AE-61875-01	AE-61875-01
30		Outlet Air Pipe	68-24021-01	68-24021-01	68-24021-01	68-24021-01
31		Outlet Air Pipe Gasket	68-24022-02	68-24022-02	68-24022-02	68-24022-02
32		Top Plate	AS-61872-02	AS-61872-02	AS-61872-02	AS-61872-03
33		Vinyl Grommet - 2 in.	56-22114-06	56-22114-06	56-22114-06	56-22114-06
34		Heat Exchanger Assembly	See Heat Exchanger Group			
35		Limit - Main Limit (Heat Exchanger Panel)	See Heat Exchanger Group			
37		Connector/Transition	68-24047-08	68-24047-08	68-24047-08	68-24047-09
38		Elbow	68-24013-01	68-24013-01	68-24013-01	68-24013-01
39		Tubing	79-25353-82	79-25353-82	79-25353-82	79-25353-82
44		Capacitor - Blower Motor	See Blower Group			
45		Capacitor - Induced Draft Blower	See Electrical Group			
46		Control Mounting Plate	AE-67877-01	AE-67877-01	AE-67877-01	AE-67877-01
47		Integrated Furnace Control Board (IFC)	See Gas Controls			
48		Transformer	See Electrical Group			
57		Gas Valve	See Gas Controls			
59		Ignitor Bracket	See Gas Controls			
60		Ignitor	See Gas Controls			

No.	Notes	MODEL HEATING INPUT VARIATIONS	GLUA ALL ALL			
PARTS BAG						
		Complete Parts Bag	AS-100717-01			
27		Locknut - Fresh Air Damper	64-24031-01			
28		Male Adapter	68-24028-01			
29		O-Ring Gasket	68-24032-01			
		1/2 in. PVC Pipe - 4 in.	68-22024-04			
		1/2 in. Tee	68-21980-02			
		Hose Clamp	64-22043-01			
		Hose Clamp (2)	64-22043-02			
		Plug - Nylon 7/8 in. (2)	45-22926-01			
		Plug - Nylon 1-1/8 in.	45-22926-02			
		PVC Vane	68-23473-01			
		PVC Wind Vane	68-24049-01			
		Grommet - Blower Shelf (5/8 in. ID) - Not included in Parts Bag	56-22521-03			
		Grommet - Blower Shelf (1/2 in. ID) - Not included in Parts Bag	56-24008-01			

No.	Notes	MODEL	GLUA 45E 3B	GLUA 60E 3B	GLUA 75E 3B	GLUA 75E 4B
		HEATING INPUT BLOWER DESIGNATION				
ELECTRICAL GROUP						
3	Stk	Pressure Switch	42-24196-01	42-24196-04	42-24196-01	42-24196-01
9	Stk	Induced Draft Blower w/Gasket	70-24033-01	70-24033-01	70-24033-01	70-24033-01
12	Stk	Pressure Switch	42-24195-03	42-24195-03	42-24195-03	42-24195-03
14		Door Switch - Push Button	42-22692-02	42-22692-02	42-22692-02	42-22692-02
17		Wiring Harness - 6 pin to (2 pin/2 flag terminals), 4 wires	45-24371-27	45-24371-27	45-24371-27	45-24371-27
18		Wiring Harness - 4 pin to 3 terminals (2 eyelets/1 insulated) and 1 strip back, 4 wires	45-24371-12	45-24371-12	45-24371-12	45-24371-12
19		Twist Lock Wiring Harness - 6 pin to 4 pin and 9 pin to 8 terminals, 12 wires	45-24393-01	45-24393-01	45-24393-01	45-24393-01
20		Wiring Harness - 9 pin to (9 pin/4 pin), 8 wires	45-24371-01	45-24371-01	45-24371-01	45-24371-01
35	Stk	Limit - Main Limit (Heat Exchanger Panel)	47-25350-06	47-25350-05	47-25350-09	47-25350-01
45	Stk	Capacitor - Induced Draft Blower	43-20847-43	43-20847-43	43-20847-43	43-20847-43
47		Integrated Furnace Control Board (IFC)	See Gas Controls			
48	Stk	Transformer	46-24124-03	46-24124-03	46-24124-03	46-24124-03
		Transformer Fuse (Long - 1-1/4 in.)	46-22863-84	46-22863-84	46-22863-84	46-22863-84
49	Stk	Limit - Manual Reset (Burner Compartment)	47-22861-02 (1)	47-22861-02 (1)	47-22861-02 (2)	47-22861-02 (2)

No.	Notes	MODEL	GLUA 90E 4B	GLUA 90E 5B	GLUA 105E 5B	GLUA 120E 5B
		HEATING INPUT BLOWER DESIGNATION				
ELECTRICAL GROUP						
3	Stk	Pressure Switch	42-24196-04	42-24196-04	42-24196-03	42-24196-02
9	Stk	Induced Draft Blower w/Gasket	70-24033-01	70-24033-01	70-24033-01	70-24033-01
12	Stk	Pressure Switch	42-24195-03	42-24195-03	42-24195-03	42-24195-03
14		Door Switch - Push Button	42-22692-02	42-22692-02	42-22692-02	42-22692-02
17		Wiring Harness - 6 pin to (2 pin/2 flag terminals), 4 wires	45-24371-27	45-24371-27	45-24371-27	45-24371-27
18		Wiring Harness - 4 pin to 3 terminals (2 eyelets/1 insulated) and 1 strip back, 4 wires	45-24371-12	45-24371-12	45-24371-12	45-24371-12
19		Twist Lock Wiring Harness - 6 pin to 4 pin and 9 pin to 8 terminals, 12 wires	45-24393-01	45-24393-01	45-24393-01	45-24393-01
20		Wiring Harness - 9 pin to (9 pin/4 pin), 8 wires	45-24371-01	45-24371-01	45-24371-01	45-24371-01
35	Stk	Limit - Main Limit (Heat Exchanger Panel)	47-25350-01	47-25350-01	47-25350-07	47-25350-01
45	Stk	Capacitor - Induced Draft Blower	43-20847-43	43-20847-43	43-20847-43	43-20847-43
47		Integrated Furnace Control Board (IFC)	See Gas Controls			
48	Stk	Transformer	46-24124-03	46-24124-03	46-24124-03	46-24124-03
		Transformer Fuse (Long - 1-1/4 in.)	46-22863-84	46-22863-84	46-22863-84	46-22863-84
49	Stk	Limit - Manual Reset (Burner Compartment)	47-22861-02 (2)	47-22861-02 (2)	47-22861-02 (2)	47-22861-02 (3)

No.	Notes	MODEL	GLUA	GLUA	GLUA	GLUA
		HEATING INPUT	45E	60E	75E	75E
		BLOWER DESIGNATION	3B	3B	3B	4B
BLOWER GROUP						
13	Stk	Blower Assembly (Includes items 40 - 44)	AS-61697-15	AS-61697-86	AS-61697-86	AS-61697-87
40	Stk	Blower Wheel	70-22688-01	70-22688-01	70-22688-01	70-24119-01
41		Blower Housing	AS-61674-02	AS-61674-02	AS-61674-02	AS-61674-02
42	Stk	Blower Motor	51-24042-01	51-24144-01	51-24144-01	51-24146-01
43		Motor Mounting Leg (4)	AE-61698-02	AE-61698-02	AE-61698-02	AE-61698-02
44	Stk	Capacitor - Blower Motor	43-100509-42	43-100509-42	43-100509-42	43-100509-43

No.	Notes	MODEL	GLUA	GLUA	GLUA	GLUA
		HEATING INPUT	90E	90E	105E	120E
		BLOWER DESIGNATION	4B	5B	5B	5B
BLOWER GROUP						
13	Stk	Blower Assembly (Includes items 40 - 44)	AS-61697-91	AS-61697-88	AS-61697-88	AS-61697-89
40	Stk	Blower Wheel	70-24041-01	70-24041-01	70-24041-01	70-20602-01
41		Blower Housing	AS-61674-08	AS-61674-08	AS-61674-08	AS-61674-03
42	Stk	Blower Motor	51-24145-01	51-24146-01	51-24146-01	51-24146-01
43		Motor Mounting Leg (4)	AE-61698-02	AE-61698-02	AE-61698-02	AE-61698-02
44	Stk	Capacitor - Blower Motor	43-100509-43	43-100509-43	43-100509-43	43-100509-43

No.	Notes	MODEL HEATING INPUT BLOWER DESIGNATION	GLUA 45E 3B	GLUA 60E 3B	GLUA 75E 3B	GLUA 75E 4B
HEAT EXCHANGER, BURNER / MANIFOLD GROUP						
34	Stk	Heat Exchanger Assembly	AS-61805-22	AS-61805-23	AS-61805-24	AS-61805-26
35	Stk	Limit - Main Limit (Heat Exchanger Panel)	See Electrical Group			
49	Stk	Limit - Manual Reset (Burner Compartment)	See Electrical Group			
50		Bracket - (Limit - Manual Reset)	AE-61913-02 (1)	AE-61913-02 (1)	AE-61913-02 (2)	AE-61913-02 (2)
51		Burner Shield	AE-61807-01	AE-61807-02	AE-61807-03	AE-61807-03
52		Burner Diffuser	AE-61882-12	AE-61882-11	AE-61882-07	AE-61882-07
53	Stk	Burner Assembly	AS-61984-03	AS-61984-04	AS-61984-05	AS-61984-05
54		Burner Support Bracket (2)	AE-61808-01	AE-61808-01	AE-61808-01	AE-61808-01
55		Burner Support	AE-61809-11	AE-61809-12	AE-61809-13	AE-61809-13
56	Stk	Manifold (w/o Orifices)	81-24395-01	81-24395-02	81-24395-03	81-24395-03
58		Burner Orifice - Natural Gas	See Orifice Selection Chart			
58		Burner Orifice - LP	See Orifice Selection Chart			
		Number of Orifices	(3)	(4)	(5)	(5)

No.	Notes	MODEL HEATING INPUT BLOWER DESIGNATION	GLUA 90E 4B	GLUA 90E 5B	GLUA 105E 5B	GLUA 120E 5B
HEAT EXCHANGER, BURNER / MANIFOLD GROUP						
34	Stk	Heat Exchanger Assembly	AS-61805-25	AS-61805-25	AS-61805-27	AS-61805-28
35	Stk	Limit - Main Limit (Heat Exchanger Panel)	See Electrical Group			
49	Stk	Limit - Manual Reset (Burner Compartment)	See Electrical Group			
50		Bracket - (Limit - Manual Reset)	AE-61913-02 (2)	AE-61913-02 (2)	AE-61913-02 (2)	AE-61913-02 (3)
51		Burner Shield	AE-61807-04	AE-61807-04	AE-61807-05	AE-61807-06
52		Burner Diffuser	AE-61882-08	AE-61882-08	AE-61882-09	AE-61882-10
53	Stk	Burner Assembly	AS-61984-06	AS-61984-06	AS-61984-07	AS-61984-08
54		Burner Support Bracket (2)	AE-61808-01	AE-61808-01	AE-61808-01	AE-61808-01
55		Burner Support	AE-61809-14	AE-61809-14	AE-61809-15	AE-61809-16
56	Stk	Manifold (w/o Orifices)	81-24395-04	81-24395-04	81-24395-05	81-24395-06
58		Burner Orifice - Natural Gas	See Orifice Selection Chart			
58		Burner Orifice - LP	See Orifice Selection Chart			
		Number of Orifices	(6)	(6)	(7)	(8)

No.	Notes	MODEL GAS CODE	GLUA GY	GLUA EJ	GLUA EL
GAS CONTROLS					
47	Stk	Integrated Furnace Control Board (IFC)	62-25338-01	62-24140-04	62-24140-04
57	Stk	Gas Valve - Natural Gas	60-100394-02	60-22866-01	60-23490-01
57	Stk,1	Gas Valve - LP	See Note 1	See Note 1	See Note 1
59		Ignitor Bracket	AE-61885-02	AE-61885-02	AE-61885-02
60	Stk	Ignitor	62-24141-04	62-24141-04	62-24141-04
62	Stk	Flame Sensor	62-23543-01	62-23543-01	62-23543-01
	Stk	LP Conversion Kit	FP-02	FP-02	FP-02

90% GAS FURNACE - ORIFICE SELECTION CHART - NATURAL GAS

CAUTION: Selection of the correct Natural Gas Orifice requires the following information for the specific installation:

- 1) Altitude in of the installation (ft.).
- 2) Average energy content of the Natural Gas fuel from the local supplier (BTU/cu. ft.).

For detailed information and instructions for Orifice selection, see the Gas Furnace LP Conversion Kit Index 92-21519-59 and the latest edition of the National Fuel Gas Code Handbook, or the National Standard of Canada, Natural Gas and Propane Installation Code, CAN B149.1.

CAUTION: This information is provided for replacement purposes only. Conversion for operation at High Altitude must be done using the kit specified on the product specification sheet for the unit.

NOTE: This Orifice sizing chart is based on 15,000 BTU/HR per burner.

NOTE: Factory installed orifices are calculated and sized based on a Natural Gas heating value of 1075 BTU/cu. ft. and an elevation of 0 - 3000 ft.

Energy Value (BTU/cu. ft.)	Elevation (ft.)							
	0 - 1999	2000 - 2999	3000 - 3999	4000 - 4999	5000 - 5999	6000 - 6999	7000 - 7999	8000 - 8999
850	62-22175-47	62-22175-48	62-22175-48	62-22175-49	62-22175-49	62-22175-49	62-22175-50	62-22175-50
900	62-22175-48	62-22175-49	62-22175-49	62-22175-49	62-22175-50	62-22175-50	62-22175-50	62-22175-51
975	62-22175-49	62-22175-50	62-22175-50	62-22175-50	62-22175-51	62-22175-51	62-22175-51	62-22175-52
1075	62-22175-50	62-22175-51	62-22175-51	62-22175-51	62-22175-51	62-22175-52	62-22175-52	62-22175-52
1170	62-22175-51	62-22175-51	62-22175-52	62-22175-52	62-22175-52	62-22175-53	62-22175-53	62-22175-53

90% GAS FURNACE - ORIFICE SELECTION CHART - LP

CAUTION: Selection of the correct LP Orifice requires the altitude of the specific installation (ft.).

For detailed information and instructions for Orifice selection, see the Gas Furnace LP Conversion Kit Index 92-21519-59 and the latest edition of the National Fuel Gas Code Handbook (NFG), or the National Standard of Canada, Natural Gas and Propane Installation Code, CAN B149.1.

CAUTION: This information is provided for replacement purposes only. Conversion to LP or for operation at High Altitude should be done using the kit(s) specified on the product specification sheet for the unit.

NOTE: This Orifice sizing chart is based on 15,000 BTU/HR per burner. Also, the chart is developed using the specified pressure setting of 10 in. water column instead of the 11.0 in water column used by the NFG and CANB149.1.

NOTE: Orifices supplied in the LP Conversion Kit are calculated and sized based on an altitude of 0 - 2000 ft.

Elevation (ft.)	Orifice							
0 to 2000 ft.	62-22175-91							
2001 to 3000	62-22175-91							
3001 to 4000	62-22175-90							
4001 to 5000	62-22175-58							
5001 to 6000	62-22175-59							
6001 to 7000	62-22175-60							
7001 to 8000	62-22175-62							
8001 to 9000	62-22175-63							
9001 to 1000	62-22175-64							

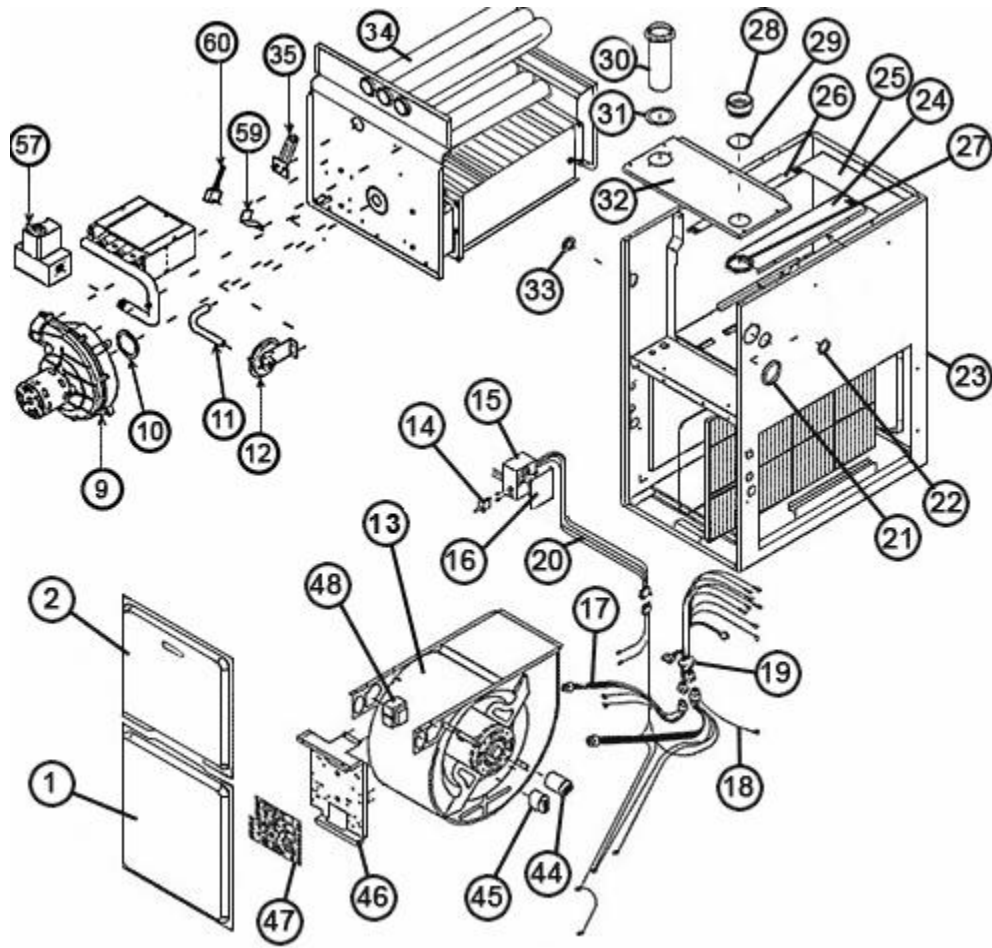

Exploded View

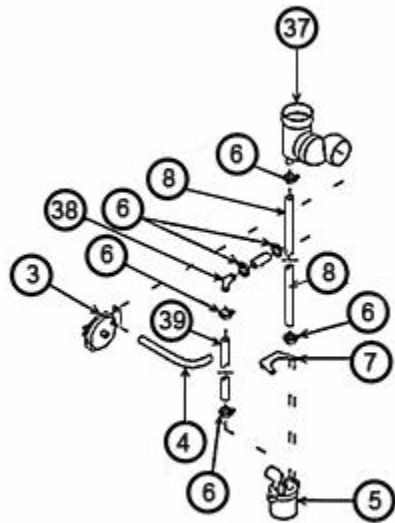

Drain Trap Parts

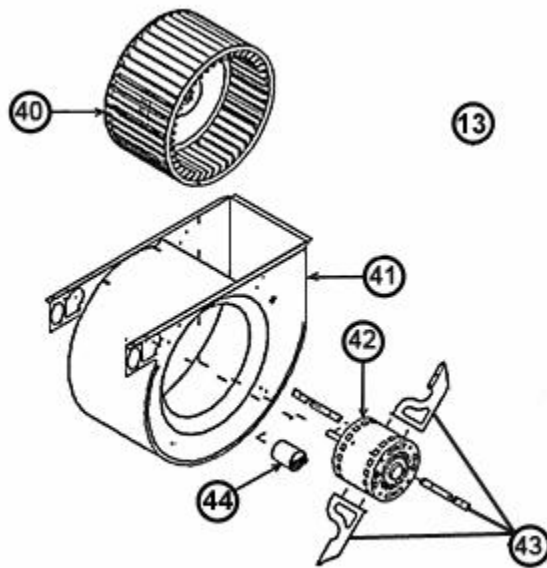

Blower Assembly

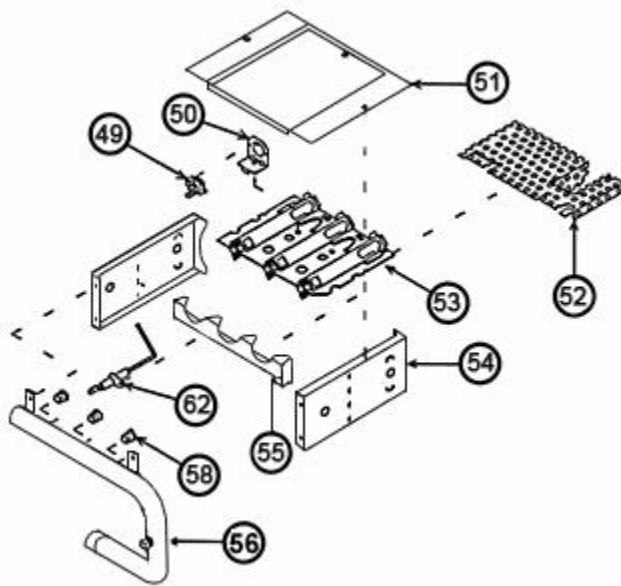

Burner Assembly

NOTES

Stk It is recommended that stock be maintained for this part.
N/A Not Applicable
1 Order Gas Valve for Natural Gas along with LP Conversion Kit