



# **OWNER'S MANUAL**

## **BBQ020**



## **RESIDENTIAL PELLET GRILL-SMOKER**

### **FOR OUTDOOR USE ONLY!**

**“TASTE THE DIFFERENCE”**

Please read this entire manual before assembly, installation of your Traeger Pellet Grill. Failure to follow these instructions could result in property damage, bodily injury or even death. Contact your local building or fire official about restrictions and installation inspection requirements in your area.

**SAVE THESE INSTRUCTIONS**

**A MAJOR CAUSE OF FIRES IS FAILURE TO MAINTAIN REQUIRED CLEARANCES (AIR SPACES) TO COMBUSTIBLES MATERIALS. IT IS OF UTMOST IMPORTANCE THAT THIS PRODUCT BE INSTALLED ONLY IN ACCORDANCE WITH THESE INSTRUCTIONS.**



**DANGER!** Hazardous voltage is present which can shock, burn or cause death. Disconnect the power cord before servicing the Grill unless otherwise noted in the Owner's Manual.

**DANGER!** Never use or store flammable liquids near the Grill.

**DANGER!** Never use gasoline or lighter fluid to manually light your Grill. Use **ONLY** Alcohol Gel for this procedure **AND** according to the instructions in the Owner's Manual.

**WARNING!** When operating this Grill, maintain a **MINIMUM** distance of 12" from the Grill to combustibles.

**WARNING!** When operating this Grill under overhead combustibles a **MINIMUM** of 40 inches is required.

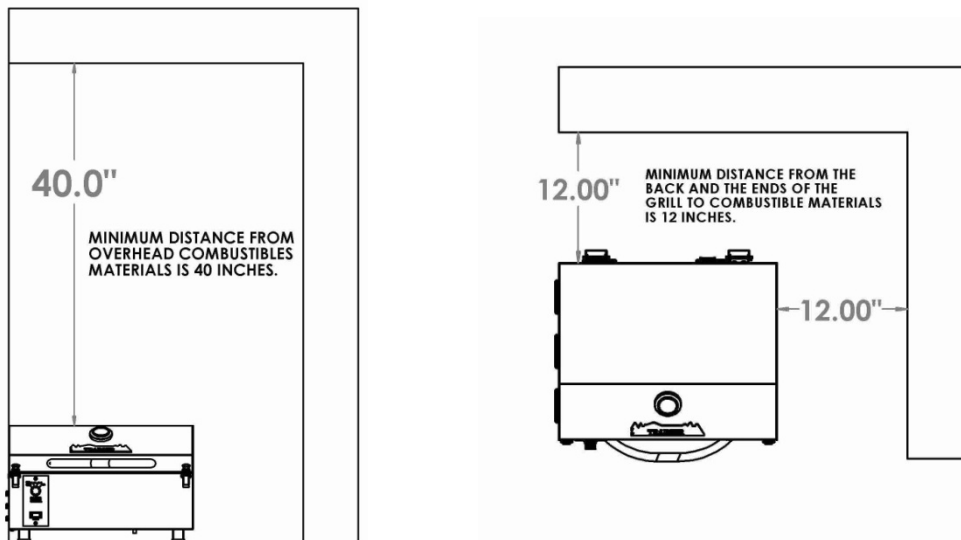

**WARNING!** Assemble and operate this Grill **ONLY** per the instructions in this Owner's Manual.

**WARNING!** This Grill is intended for **OUTDOOR USE ONLY**.

**WARNING!** Never use heating fuel pellets in the Grill, due to potential hazardous contaminants and additives that may be present.

**WARNING!** Use **ONLY** TRAEGER BRAND BBQ WOOD PELLETS, which are specifically made to work in our Grills. Traeger wood pellets are rated for 8500 BTU per LBS with an ash content of 2%.

**CAUTION!** Always store wood pellets in a dry location, away from heat-producing appliances and other fuel containers.

**CAUTION!** Keep the Grill clean – See the cleaning Instructions in this Owner's Manual.

**CAUTION!** Do not use accessories not specified for use with this Grill.

# INTRODUCTION

Congratulations on your purchase of this Traeger Wood Pellet Grill, Model BBQ020. With proper set-up, operation and maintenance, the Grill will provide you with delicious food and years of cooking enjoyment.

**NOTE: NUMBERS FOLLOWING PART NAMES THROUGHOUT THIS MANUAL REFER TO THE COMPONENT DIAGRAM.**

When you un-box the Grill, make sure you have, and can identify all of the following parts:

- (1) Door handle (9)
- (2) Bag of screws and washers included 1/4-20 x .375 bolt (17), .250 lock washer (18), and .250 flat washer (19).
- (3) Drip pan assembly (41).
- (4) Porcelain Grill Grate (58).

You will need to complete the assembly which includes:

- 1) Mounting the handle (9) to the lid assembly (59).

Follow these step by step instructions and you'll be cooking in no time!

## TOOLS SUPPLIED FOR ASSEMBLY

7/16" / 1/2" combo wrench

Record your date of purchase here: \_\_\_\_\_

Record your serial number here: \_\_\_\_\_

# SECTION ONE: ASSEMBLY INSTRUCTIONS

## MOUNTING THE HANDLE TO THE LID:

1. Insert .250 lock washers (18), .250 flat washers (19) onto 1/4-20 bolt (17) and insert into hole on the inside of the lid. Then align the handle to the screw and insert into threaded hole and leave loose. Repeat the process on the other side of the handle.
2. Then tighten the bolts till they are snug. **Do Not Over Tighten The Bolts.**

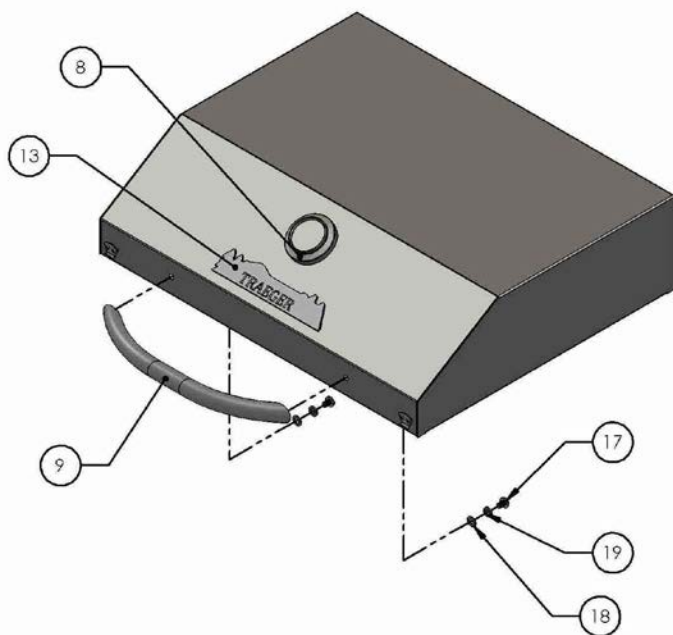

## INSTALLING THE DRIP PAN ASSEMBLY AND GRILL:

1. Insert the drip pan assembly (41) onto the inside of the BBQ020 body and insert into the body cutout.
2. Insert the drip pan support into the alignment brackets this will create a lean towards the back of the grill body.
3. Insert the Grill (58) into the recessed body inserts with the 3 parallel bars onto inserts.

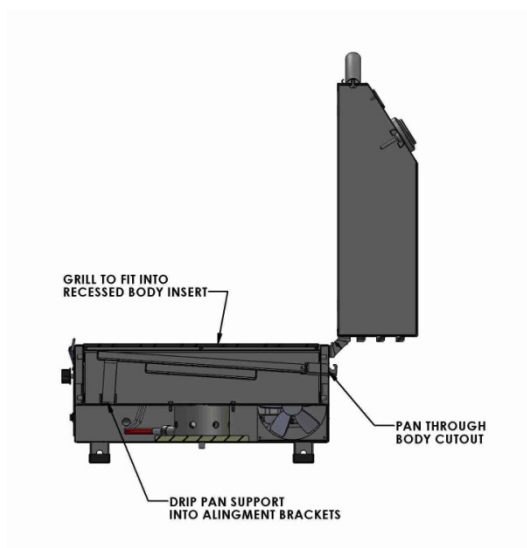
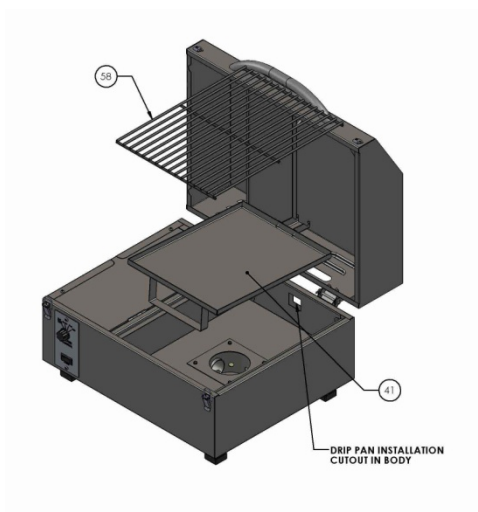

## SECTION TWO: INITIAL FIRING INSTRUCTIONS

*(To be used on initial firing or anytime the Grill runs out of Pellets)*

In order to ensure proper operation of the Grill, you must first allow the Auger Tube to be “charged” with Pellets.

- 1) Open the Door and remove the Porcelain Grill, Grease Drain Pan Assembly from inside the Grill.
- 2) Make sure the Switch is in the OFF position and Dial Knob is in the Shut Down Cycle position. Plug the Power Cord into an appropriate, grounded electrical outlet.
- 3) Open the Pellet Hopper Lid and locate the Auger. Make sure there are no foreign objects in the Auger. Turn the Switch to On and the Dial Knob to Smoke and look into the Pellet Hopper to confirm the Auger is turning. At the same time, place your fingers over the Firepot and feel the air movement from the Draft Inducer Fan. Look to see if the Hot Rod is getting hot. **DO NOT TOUCH IT!** Turn the Switch to the OFF position.
- 4) Fill the Pellet Hopper with TRAEGER BBQ PELLETS. **WARNING! USE ONLY TRAEGER BRAND BBQ PELLETS, which are specifically made to work in our Grills. NEVER use heating fuel pellets in the Grill.** Turn the Switch to ON, set the Temperature Dial Knob to HIGH. Note: During the initial charging of the Auger, it will take time for the Pellets to travel from the Pellet Hopper to the Firepot. When the Pellets begin to fall into the Firepot, turn the Switch to OFF and then set the Dial Knob to the Smoke setting.
- 5) Turn the Switch to the ON position and let the Pellets come to full flame. Once you see flames come out of the Firepot, turn the Switch to OFF, the Dial Knob to Shut Down Cycle and let the Grill cool down. **RECOMMENDATION for ease of clean-up: Line the Grease Drain Pan with heavy-duty aluminum foil. Be sure the edges and ends of the foil are tight against the bottom of the Grease Drain Pan.** Position the foil lined Grease Drain Pan and Porcelain Grill in their proper locations.
- 6) With the Door open, turn the Switch to ON and set the Dial Knob to SMOKE. In approximately 2 minutes you will notice whitish-gray smoke coming out of the Grill as the Pellets ignite. After assuring the Pellets have ignited, close the Door and set the Temperature Dial to any cooking setting desired.
- 7) **Note: Before cooking the first batch of food in your new Grill, you will need to season the Grill. Turn the Temperature Dial to HIGH and run for 45 minutes at this setting with the Door closed. This must be done before cooking any food on the Grill.**
- 8) The Grill should be allowed to pre-heat for approximately 10 minutes with the Door closed before placing food in the Grill.

### **ALWAYS START THE GRILL ON SMOKE SETTING WITH THE DOOR OPEN**

**Once the Pellets are ignited, close the Door and  
set the Temperature Dial to any cooking temperature desired.**

**NOTE: When operating this Grill, maintain a minimum  
clearance of 12 inches from Grill to combustibles**

## SECTION THREE: SUBSEQUENT START-UP

With the Door open, turn the Switch to ON position and Dial Knob to SMOKE. In approximately 2 minutes you will notice whitish-gray smoke coming out of the Grill as the Pellets ignite. After assuring the Pellets have ignited, close the Door and set the Temperature Dial to any cooking setting desired.

**WARNING!** If at any time, the Grill fails to light or the fire in the Firepot goes out while cooking or smoking, when sufficient pellets are still in the Pellet Hopper, it is important to follow these steps. Failure to do so may cause a hazardous “over-firing” of your grill due to an excess of unburned pellets in the Firepot.

- 1) **DANGER!** Turn the Switch OFF (o) and disconnect the Power Cord. If the Grill is still hot, allow it to thoroughly cool. Open the Door and remove all food, the Porcelain Grill, Grease Drain Pan Assembly.
- 2) **WARNING!** Remove all unburned pellets and ash from inside and around the Firepot. (**See instructions for proper handling and disposal of ash in Section Five**)
- 3) Before replacing the Grease Drain Pan Assembly and the Porcelain Grill, plug the Power Cord into an appropriate, grounded electrical outlet and restart the Grill. Pellets should fall into the Firepot and the Hot Rod should begin to heat (it will start to turn red). **CAUTION! Do not touch it.**
- 4) If this procedure **is** successful, you will soon see flames come out of the Firepot. Then turn the Switch OFF (o), and let the Grill cool down. Position the Grease Drain Pan Assembly and Porcelain Grill in their proper locations. With the Door open, turn the Switch ON (--) and the Dial Knob to SMOKE. In approximately 2 minutes you will notice whitish-gray smoke coming out of the Grill as the Pellets ignite. After assuring the Pellets have ignited, close the Door and set the Dial Knob to any cooking setting desired.
- 5) If this procedure **is not** successful, see **Section Six: FREQUENTLY ASKED QUESTIONS** for troubleshooting tips or contact Traeger Technical Support (**Section Seven**) to help diagnose the problem **before** proceeding to the **MANUAL LIGHTING INSTRUCTIONS** below.

### MANUAL LIGHTING INSTRUCTIONS:

If the **Hot Rod** only is not operating, the Grill can still be used to cook and smoke using the **MANUAL LIGHTING PROCEDURE** below:

- 1) **DANGER!** Turn the Switch OFF (o) and disconnect the Power Cord. Allow the Grill to thoroughly cool if it is still hot. Remove the body left panel and disconnect the Hot Rod (Purple / White wire pair as shown in the wiring diagram near the end of this manual). You will need to remove the Body Left Panel to access the wiring. Once the Hot Rod is disconnected, replace the Body Left Panel and plug the Power Cord back into an appropriate, grounded electrical outlet.
- 2) Open the Pellet Hopper and fill with TRAEGER BBQ PELLETS.

**WARNING! USE ONLY TRAEGER BRAND BBQ WOOD PELLETS, which are specifically made to work in our Grills. NEVER use heating fuel pellets in the Grill due to potential hazardous contaminants and additives that may be present.**

- 3) Remove the Porcelain Grill, Grease Drain Pan Assembly to expose the Firepot  
In the bottom of the Grill.
- 4) Pour 1/2 cup of TRAEGER BBQ PELLETS into the Firepot.
- 5) Squirt 2 tablespoons of Alcohol Gel fire lighter into the Firepot on top of the Pellets.

**DANGER!** Never use gasoline, gasoline-type lantern fuel, kerosene, charcoal lighter fluid or similar liquids to start or “freshen up” a fire in this Grill. Keep all such liquids well away from the Grill when in use.

- 6) Carefully light the Alcohol Gel with a fireplace match or a long-reach butane lighter.

**DANGER!** Never squirt Alcohol Gel into a burning fire or a hot Firepot. The Alcohol Gel bottle could explode and cause a fire, serious injury or death.

- 7) Let the Alcohol Gel and Pellets burn for approximately 4 minutes.
- 8) After assuring the Pellets have ignited, install the Grease Drain Pan Assembly and Porcelain Grill back in place.

**CAUTION!** You will now have a fire in the Firepot. **Be careful not to burn yourself** when you install these components. Gloves are recommended.

- 9) Turn the Switch ON (→) and the Dial Knob to the Smoke, Medium, or High setting desired. With the Door closed, let the Grill pre-heat for approximately 10 minutes before placing food in the Grill.

## Control Shutdown cycle

The control for the BBQ020 comes with an automatic shut down cycle. When finished cooking on your BBQ020 set the Dial Knob to the Shut Down Cycle position, this will leave the Draft Induction Fan running for ten minutes to burn any excess pellets in the fire pot. After the fan runs for ten minutes the controller will power off and the fan and it will stop running.

**CAUTION!** The main power switch will shut the power off to the controller and the Dial Knob switch will cut off power to the grill components only. When servicing the controller or any parts ensure that the power supply is disconnected to avoid a shock hazard.

## SECTION FOUR: OPERATING TIPS

- 1) The Temperature Dial can be changed at any time to increase or decrease the cooking temperature of the Grill. The HIGH/HIGHER Temperature settings are for Grilling. The MED/MID RANGE Temperature settings are for Slow Cooking. The SMOKE setting is for Smoking and adding Smoke Flavor to foods being cooked. The SMOKE setting can also be used to “hold” foods at approximately 180 to 200 degrees F.
- 2) Your TRAEGER PELLET GRILL should never be moved while it is hot. If you are transporting your Grill in a vehicle after cooking on it, make sure the fire is completely out and the Grill is COLD before placing it in any vehicle. NEVER put water into the Firepot. It will jam the Auger.
- 3) The TRAEGER PELLET GRILL is designed to operate with the Door CLOSED. Cooking with the Door open greatly lengthens your cooking time.
- 4) NEVER add Pellets by hand to a hot Firepot. This is dangerous and you may be seriously burned. If you run out of Pellets and lose your fire while cooking, let the Grill completely cool and start again with the **INITIAL FIRING INSTRUCTIONS**.

- 5) Make sure the Grease Drain Pan Assembly is properly seated on its locating brackets. The support bracket of the Grease Drain Assembly should be inserted into the alignment brackets. If not seated properly, direct heat and flame could come up out of the Firepot and cause a grease fire in the Grill.
- 6) When estimating cooking times, the outside temperature will be an important factor. If it is hot outside, it will take less time for food to cook. If it is cold, wet or windy, it will take longer.
- 7) Grease fires are caused by not properly maintaining the Grill by failing to clean your Grease Drain Pan Assembly. In the unlikely event of a grease fire while cooking, **TURN THE SWITCH OFF and KEEP THE DOOR CLOSED** until the fire is completely out. Never keep the Door open during a grease fire. If it does not go out, lightly sprinkle baking soda on the fire. **Be careful not to burn yourself.** If this does not work then carefully remove the food from the Grill and keep the Door closed until the fire is completely out. **Again, be careful not to burn yourself.** When the Grill is completely cool, remove the Porcelain Grill and replace the foil on the Grease Drain Pan Assembly. Clean any grease accumulation from the grease drain chute. Replace the Grease Drain Pan Assembly and the Porcelain Grill in their proper positions, restart the Grill and resume cooking.

#### 8) **CARBON MONOXIDE:**

**WARNING!** Follow these guidelines to prevent this colorless, odorless gas from poisoning you, your family or others.

- Know the symptoms of carbon monoxide poisoning: headache, dizziness, weakness, nausea, vomiting, sleepiness and confusion. Carbon monoxide reduces the blood's ability to carry oxygen. Low blood oxygen levels can result in loss of consciousness and death.
- See a doctor if you or others develop cold or flu-like symptoms while cooking or in the vicinity of this Grill. Carbon monoxide poisoning, which can easily be mistaken for a cold or flu, is often detected too late.
- Alcohol consumption and drug use increase the effects of carbon monoxide poisoning.

Carbon monoxide is especially toxic to mother and child during pregnancy, infants, the elderly, smokers and people with blood or circulatory problems, such as anemia or heart disease.

## **SECTION FIVE: MAINTAINING YOUR NEW GRILL**

- 1) Change the aluminum foil on the Grease Drain Pan Assembly frequently. Periodically, clean the grease out of the grease drain chute and off of the interior surfaces of the Grill. Empty the Grease Bucket occasionally and line with aluminum foil for easy clean-up. It is easier to clean off accumulated grease when the Grill is warm. **BE CAREFUL NOT TO BURN YOURSELF.** If too much grease is allowed to build up on the Grease Drain Pan Assembly a grease fire could result. We recommend cleaning these locations regularly.
- 2) Outside surfaces: DO NOT use oven cleaner, abrasive cleansers or abrasive cleaning pads on the outside Grill surfaces. Use warm soapy water to cut the grease.
- 3) If the Grill is stored outside during the rainy season, care should be taken to ensure that water does not get into the Pellet Hopper. Wood pellets, when wet, expand greatly and will jam you Auger. **A TRAEGER GRILL COVER to protect the Grill is highly**



**recommended! Covers are available from your local Traeger Dealer, or log on to our Web Site – [www.traegergrills.com](http://www.traegergrills.com).**

- 4) Depending on use, periodically remove the Porcelain Grill, Grease Drain Pan Assembly and clean the ash from in and around the Firepot. A shop-vac is handy for this chore. Make sure the Grill is COLD before starting this procedure.
- 5) We recommend keeping a long-handled cleaning brush near the Grill. After removing your food, give the Porcelain Grill a quick brushing. It takes only a minute and it will be ready the next time you want to use the Grill. **Be careful not to burn yourself.**

## **SECTION SIX: FREQUENTLY ASKED QUESTIONS**

### **WHY WON'T MY GRILL IGNITE?**

- 1) Verify power at the electrical outlet.
  - a) If Power Cord is connected to a GFI (Ground Fault Interrupter), check and reset if necessary.
  - b) Initiate startup.  
**Still no ignition – Proceed to step 2.**
- 2) Disconnect Power Cord from electrical outlet.
  - a) Remove the Control and check the fuse on back. Replace the fuse if blown.  
**Reinstall the Control!**
  - b) Unplug Hot Rod connector (Purple/White wire pair), plug Power Cord into an appropriate, grounded electrical outlet and turn the Switch to ON and the Dial Knob to the Smoke Setting. **NOTE: At this point the Grill will not ignite.**
  - c) Check the Draft Inducer Fan and the Auger Drive Motor for operation. If both are operating -- the Hot Rod needs to be replaced. If one or both are not operating, contact Traeger Technical Support (**SECTION SEVEN**) for additional troubleshooting help. Contact your Traeger Dealer or the Traeger Parts Department (**SECTION SEVEN**) to place an order.
- 3) If the problem is identified to be a failed Hot Rod, the Grill can still be used to cook and smoke by following the **MANUAL LIGHTING INSTRUCTIONS** in **SECTION THREE** of this OWNER'S MANUAL.

### **WHY ARE NO PELLETS BEING DELIVERED INTO THE FIREPOT?**

- 1) Verify that there are Pellets in the Pellet Hopper. If this is the **INITIAL FIRING** or the Grill has run out of Pellets, allow sufficient time for the Pellets to travel from the Pellet Hopper to the Firepot (can take up to 7 minutes).
- 2) Initiate startup. See **INITIAL FIRING INSTRUCTIONS** in **SECTION TWO** of this OWNER'S MANUAL.

**Still no Pellets in the Firepot – Proceed to step 3.**

- 3) Disconnect Power Cord from electrical outlet.
  - a) Unplug the Auger Drive Motor ( Red/White wire pair connector) and the Draft Induction Fan (Orange/White wire pair connector).

- b) Reconnect the Draft Induction Fan to the Red/White wire pair and the Auger Drive Motor to the Orange/White pair.
  - c) Plug Power Cord into an appropriate, grounded electrical outlet and turn the Switch to ON and the Dial Knob to the Smoke setting..
  - d) If the Auger Drive Motor **is** operating (check the small fan blade on the back of the motor), the problem is in the Three Speed or Digital Control, which will need to be replaced. Contact your Traeger Dealer or the Traeger Parts Department (**SECTION SEVEN**) to place an order.
- 4) If the Auger Drive Motor **is not** operating but the Draft Induction Fan **is** operating, the problem is in the Auger system, which will need to be checked.
- a) With the Switch in the OFF position and the Dial Knob in the Shut Down Cycle setting, locate the small fan blade on the back of the Auger Drive Motor.
  - b) While watching the fan blade, turn the Switch to ON and the Dial Knob to Smoke. If the fan blade **does not** turn, turn the Switch to the OFF position. This indicates a defective Auger Drive Motor and it will need to be replaced. Contact your Traeger Dealer or the Traeger Parts Department (**SECTION SEVEN**) to place an order.
  - c) If the fan blade turns a bit and then stops, continue watching and turn the Switch/Dial to Shut Down Cycle. If the fan blade UNWINDS slightly, this indicates a jam in the Auger system which will need to be cleared.
  - d) Disconnect Power Cord from electrical outlet and remove Pellets from the Pellet Hopper. Check for foreign objects and wet/decomposed Pellets, both of which can cause a jam in the Auger system. The Auger will need to be removed to clear a jam in the Auger system. See "HOW DO I REMOVE THE AUGER IF IT JAMS?" section below.

## HOW DO I REMOVE THE AUGER IF IT JAMS?

For models with a fixed Auger Drive Motor:

- 1) Remove any covers necessary to access the Auger Drive Motor.
- 2) Remove the screw connecting the Auger Drive Motor shaft to the Auger shaft, using a 7/64 hex wrench and a 5/16 wrench or driver.
- 3) Remove two bolts mounting the Auger Drive Motor/Bracket assembly to the Burner Box with a 7/16 wrench.
- 4) With a small pipe wrench or locking pliers on the Auger shaft, turn the Auger counter clockwise. It will turn hard until it breaks free, then the Auger will turn freely.
- 5) Remove the Auger and clean all Pellets, ash or foreign objects from the Auger, Auger Tube and Firepot. A shop-vac is ideal for this task.
- 6) Sand the outside surfaces of the auger with medium grit sandpaper. Check the inside of the Auger Tube and sand it if needed. Vacuum sanding grit from the Auger Tube and Firepot when finished.
- 7) Reinstall the Auger into the Auger Tube, making sure that it rotates freely.
- 8) Re-attach the Auger Drive Motor/Bracket assembly, ensuring that the Auger shaft rotates freely on the Auger Drive Motor Shaft. Re-attach the Auger shaft to the Auger Drive Motor shaft.

For models with a floating Auger Drive Motor:

(Note: some units with the floating Auger Drive Motor will require metric tools.)

- 1) Remove any covers necessary to access the Auger Drive Motor.

- 2) Remove the screw connecting the Auger Drive Motor shaft to the Auger shaft and the screw retaining the Auger Bushing into the Auger Tube.
- 3) With a small pipe wrench or locking pliers on the Auger shaft, turn the Auger counter clockwise. It will turn hard until it breaks free, then the Auger will turn freely.
- 4) Remove the Auger and clean all Pellets, ash or foreign objects from the Auger, Auger Tube and Firepot. A shop-vac is ideal for this task.
- 5) Sand the outside surfaces of the auger with medium grit sandpaper. Check the inside of the Auger Tube and sand it if needed. Vacuum sanding grit out of the Auger Tube and Firepot when finished.
- 6) Reinstall the Auger Bushing and the Auger into the Auger Tube, making sure that the Auger rotates freely.
- 7) Re-attach the Auger shaft to the Auger Drive Motor shaft.

### **WHY DOES MY GRILL FIRE GO OUT ON “SMOKE” SETTING?**

Excess ash in the Firepot may be the problem.

- 1) Open the Door and remove the Porcelain Grill, Grease Drain Pan Assembly from inside the Grill.
- 2) **IMPORTANT: Remove all unburned Pellets and ash from inside and around the Firepot.** A shop-vac is ideal for this task **CAUTION! ASSURE THAT THE GRILL IS COLD TO AVOID A FIRE FROM HOT ASH.**
- 3) Replace the Grease Drain Pan Assembly and the Porcelain Grill and initiate start-up procedure.
- 4) If this didn't remedy the problem, contact Traeger Technical Support (**SECTION SEVEN**) for additional troubleshooting help.

### **THE AUGER MAKES A LOT OF NOISE WHEN I TURN THE GRILL ON AND I HAVE NOTICED A DROP IN THE GRILL TEMPERATURE. WHAT CAN I DO TO CORRECT THIS?**

In Grill models with a fixed Auger Drive Motor, you will need to “TRUE” the Auger

- 1) Remove all Pellets from the Pellet Hopper and run Pellets out of the Auger Tube.
- 2) Remove the screw connecting the Auger Drive Motor shaft to the Auger shaft, using a 7/64 hex wrench and a 5/16 wrench or driver.
- 3) Spin the Auger shaft over the Auger Drive Motor shaft. It should rotate freely, without binding.
- 4) If the Auger shaft binds, loosen the two bolts mounting the Auger Drive Motor/Bracket assembly to the Burner Box with a 7/16 wrench.
- 5) Move the Auger Drive Motor/Bracket assembly until you can freely rotate the Auger shaft over the Auger Drive Motor shaft.
- 6) Re-tighten the 7/16 bolts, making sure that the Auger End Piece Shaft still freely rotates over the Auger Drive Motor shaft.
- 7) Reinstall the screw and nut connecting the Auger Drive Motor shaft to the Auger shaft.

## **WITH THE TRAEGER DIGITAL CONTROL, WHAT DIAL SETTING IS RECOMMENDED FOR STARTING THE GRILL?**

The auto-start procedure is the same for all Grill Controls. With the Door open, turn the Switch/Dial ON and Temperature Dial to SMOKE. In approximately 2 minutes you will notice whitish-gray smoke coming out of the Grill as the Pellets ignite. After assuring the Pellets have ignited, close the Door and set the Temperature Dial to any cooking setting desired.

## **HOW DO I PROTECT MY PAINT FINISH?**

- 1) Use a protective Cover on the Grill and touch-up paint to repair any scratches. **A TRAEGER GRILL COVER to protect the Grill is highly recommended! Covers and touch-up paint are available from your local Traeger Dealer, or log on to our Web Site – [www.traegergrills.com](http://www.traegergrills.com).**
- 2) Every 90 days, use a high quality car wax on the outside surfaces of the Grill. **ONLY APPLY WAX TO A COLD GRILL.**

## **WHERE CAN I GET A NEW PART FOR MY GRILL?**

Check with your Traeger Dealer. They may have the part in stock or can order the part for you. Or you can contact the Traeger Parts Department (**SECTION SEVEN**) to place an order. In either case, please provide your name, phone number, address, Model and Serial Number of the Grill (located on a label inside the Hopper Lid), along with the part identification.

## **SECTION SEVEN: TRAEGER SUPPORT**

Parts are identified in the front of this manual on the COMPONENT DIAGRAM PAGE. To order parts: Call, E-mail or write to your Authorized Traeger Dealer or Traeger Pellet Grills. Please provide your name, phone number, address, Model and Serial Number of the Grill (located on a label inside the Hopper Lid), along with the part identification.

**TRAEGER PELLET GRILLS, LLC BLDG R-1  
10450 SW Nimbus STE A  
Portland, Or 97223-9904**

**TRAEGER TECHNICAL SUPPORT  
Available 7 Days a Week 5AM to 7PM  
Pacific Time**

**TRAEGER PARTS DEPARTMENT  
Available Weekdays 8AM to 3:30PM  
Pacific Time**

**TRAEGER SALES/ORDER DESK  
Available Weekdays 8AM to 4:30PM  
Pacific Time**

**TOLL-FREE TELEPHONE: 1-800-872-3437**

**E-mail: [service@traegergrills.com](mailto:service@traegergrills.com)  
Website: [www.traegergrills.com](http://www.traegergrills.com)**



# BBQ020 COMPONENTS LIST

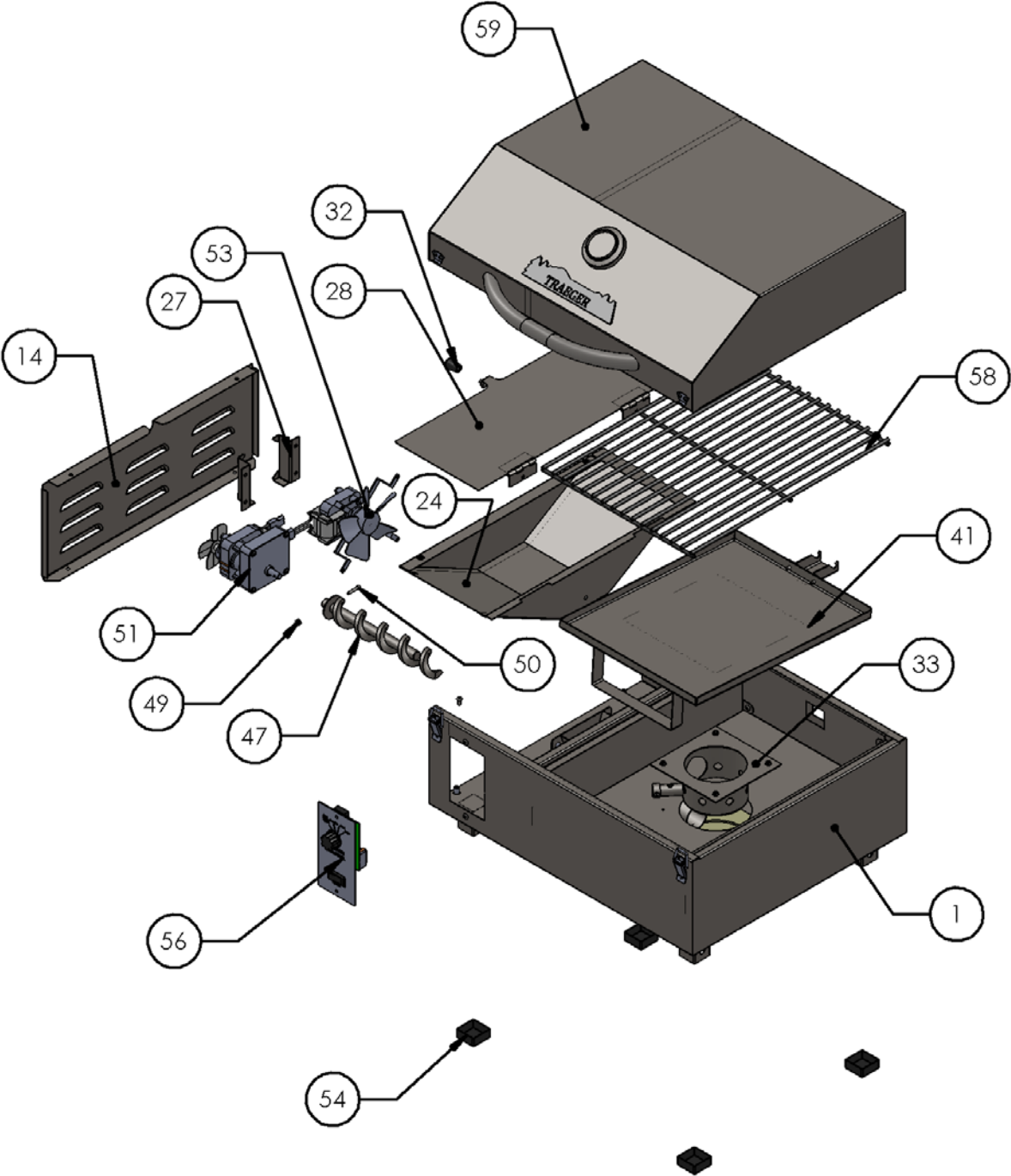

# BBQ020 LID COMPONENTS

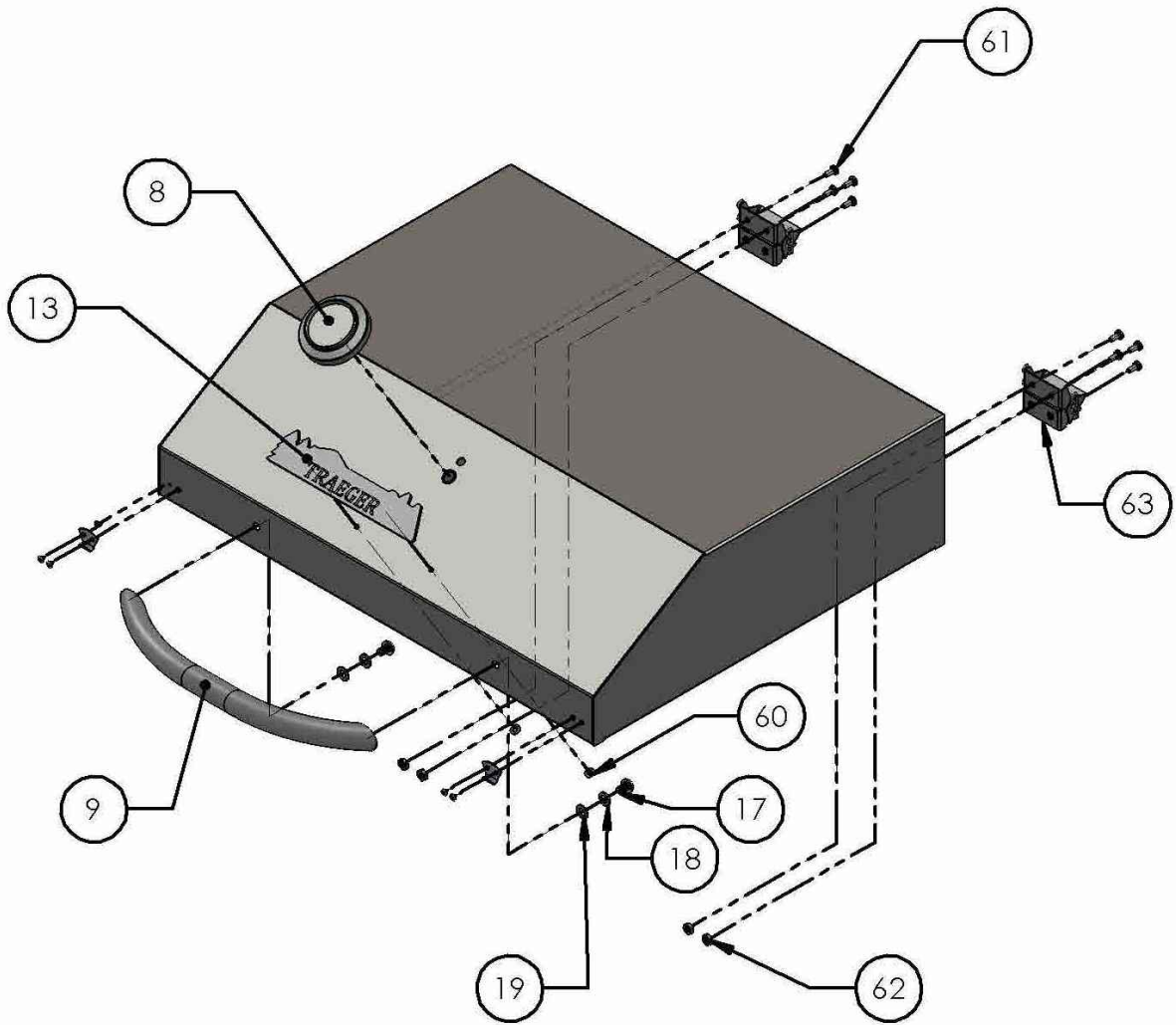

## BBQ020 PARTS LIST

ITEM#	QUANTITY	DESCRIPTION	PART NUMBER
1	1	BODY SUB ASSEMBLY	SUB330
8	1	DOME THERMOMETER 2"	BAC256
9	1	12" CHROME HANDLE	HDW227
13	1	TRAEGER NAMEPLATE	HDW151
14	1	BODY SIDE LEFT	BCA407
17	2	SCREW 1/4-20 X .375 PPHD ZINC	HDW076
18	2	WASHER LOCK .250	HDW113
19	2	WASHER FLAT .250	HDW249
24	1	HOPPER ASSEMBLY 020	SUB333
27	2	GEAR MOTOR MOUNTS	BCA414
28	1	HOPPER LID ASSEMBLY	SUB334
32	1	HOPPER LID HANDLE	HDW174
33	1	FIRE POT ASSEMBLY 020	SUB335
41	1	GREASE DRAIN PAN ASSEMBLY	SUB339
47	1	AUGER ASSEMBLY 020	SUB341
49	1	SCREW 6-32 X .750 SOCKET HD	HDW116
50	1	NUT 6-32 HEX NYLOCK	HDW111
51	1	AUGER DRIVE MOTOR	BRN100
53	1	DRAFT INDUCER FAN ASSEMBLY	FAN209
54	4	RUBBER FOOT COVER	HDW175
56	1	CONTROL 3 WAY 120V BBQ020	BAC019
58	1	PORCELAIN GRILL GRATE	HDW173
59	1	LID ASSEMBLY 020	SUB336
60	2	PUSH NUT	HDW107
61	8	SCREW 8-32 X .375 PPHD ZINC	HDW076
62	4	NUT 8-32 HEX ZINC	HDW036
63	2	LID HINGE ASSEMBLY	SUB338



# BBQ020 WIRING DIAGRAM

