

This Owner's Manual is provided and hosted by [Appliance Factory Parts](#).

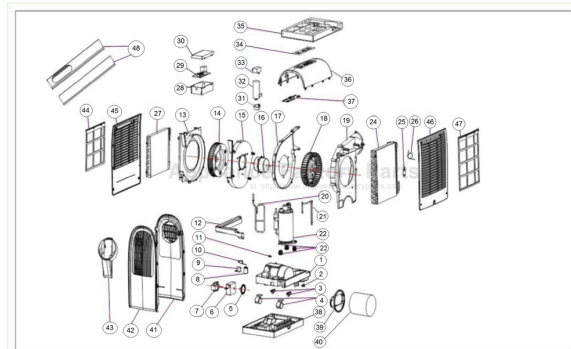

FRIEDRICH P10S Owner's Manual

[Shop genuine replacement parts for FRIEDRICH P10S](#)



[Find Your FRIEDRICH Air Conditioner Parts - Select From 1577 Models](#)

----- Manual continues below part list -----

Available Replacement Parts for FRIEDRICH P10S

P67000038	EXHAUST HOSE
P67000041	Adapter to attach exhaust hose to unit
P67000001	Rubber Stopper (Drain Plug)
P67000013	Wheel Blower A
P67000017	Wheel Blower B
P67000027	Main PCB
P67000037	Outlet For Hot Air
P67000042	Cond Filter
P67000045	Cond Filter
P67000069	Window Kit A



FRIEDRICH

ZoneAire® Compact

Portable Air Conditioner with Heat

P08S/P10S Owner's Manual

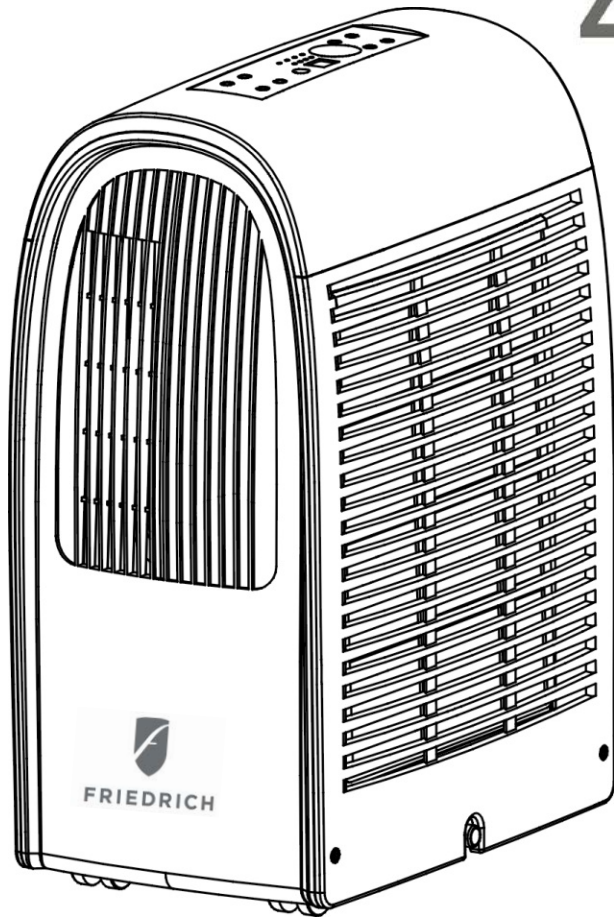

Table of Contents



Important Safety Guidelines.....	2
Introduction.....	3
Unpacking Instructions & Contents	4
Parts	5
Display Functions	6
Remote Control Functions	9
Drain Pipe	12
Maintenance & Cleaning.....	13
Installation	14
Troubleshooting.....	16



IMPORTANT SAFETY GUIDELINES

IMPORTANT

Do not install and use your portable air conditioner unit before carefully reading this instruction guide.

Please retain this manual brochure for product warranty and future reference



 WARNING	
	<p>Electrical Shock Hazard</p> <p>Make sure your electrical receptacle has the same configuration as your air conditioner's plug. If different, consult a Licensed Electrician.</p> <p>Do not use plug adapters. Do not use an extension cord. Do not remove ground prong.</p> <p>Always plug into a grounded 3 prong outlet. Failure to follow these instructions can result in death, fire, or electrical shock.</p>

 WARNING	
	<p>Refrigeration system under high pressure</p> <p>Do not puncture, heat, expose to flame or incinerate. Only certified refrigeration technicians should service this equipment. R410A systems operate at higher pressures than R22 equipment. Appropriate safe service and handling practices must be used. Only use gauge sets designed for use with R410A. Do not use standard R22 gauge sets.</p>

Your safety and the safety of others are very important.

We have provided many important safety messages in this manual and on your appliance. Always read and obey all safety messages.

 This is a safety Alert symbol. This symbol alerts you to potential hazards that can kill or hurt you and others. All safety messages will follow the safety alert symbol with the word "WARNING" or "CAUTION". These words mean:

 WARNING	Indicates a hazard which, if not avoided, can result in severe personal injury or death and damage to product or other property.
 CAUTION	Indicates a hazard which, if not avoided, can result in personal injury and damage to product or other property.

All safety messages will tell you what the potential hazard is, tell you how to reduce the chance of injury, and tell you what will happen if the instructions are not followed.

NOTICE	Indicates property damage can occur if instructions are not followed.
---------------	---

CAUTION

Operate this unit in an ambient of 89°F or less.

The heating function of the unit should be operated in an indoor ambient temperature between 44°F and 73°F.

Clean air filter periodically to enjoy the most efficient cooling.

When the unit is shut off, please wait at least 3.5 minutes before restarting; this is to prevent the compressor from being damaged.

This unit is for indoor cooling, heating and dehumidifying.

When turning on the unit, the fan will operate but the compressor will start up after the cooling alarm flashes for three minutes.

In heating function, the heating alarm will flash for 3.5 minutes before the compressor and fan start up.

If you have fuses, they should be of the time delay type. Before you install or relocate this unit, be sure that the amperage rating of the circuit breaker or time delay fuse does not exceed the amp rating listed in Table 1.

Table 1.				
MODEL	CIRCUIT RATING OR TIME DELAY FUSE		REQUIRED WALL RECEPTACLE	
	AMP	VOLT	NEMA NO.	
P08S, P10S	15	125	5-15P	

INTRODUCTION

Congratulations on your purchase and welcome to Friedrich!

ZoneAire Compact: PORTABLE AIR CONDITIONER

The Air Conditioner has been designed and manufactured to the highest standards of modern engineering.

Our product not only provides you a remote control to help user operate all the functions easily and conveniently but also includes the following benefits:

- **3-IN-1 SYSTEM: Offers cooling, dehumidification and bonus heat for year-round conditioning and comfort.**
- **Innovative design: One side offers cooling, simply turn the unit around and apply the exclusive “heat clip” for bonus heat option.**
- **Super portability with built in hose storage compartment underneath unit.**
- **Dual, easy-access antimicrobial nylon filters**
- **4-Speed fan with “Auto” setting for ultimate comfort**
- **24-hour timer for both cooling and dehumidification**
- **Unique Sleep Control function – Increases temperature 2 degrees every 4 hours**
- **LCD remote control**
- **Moves easily from room to room on easy glide castors.**

UNPACKING INSTRUCTIONS & CONTENTS

UNPACKING INSTRUCTIONS

1. Place the unit in the correct upright position before unpacking.
2. Cut the two packing straps.
3. Slide the carton in an upward motion and it will release from the base.
4. Grip the carry handles located on either sides of the unit and carefully lift until it slides out of the foam base.
5. Lift and lean the unit slightly to take out exhaust hose from unit's bottom as picture.
6. Install the exhaust hose on the unit before operating the unit.

CONTENTS

1. Air conditioner unit
2. Exhaust Hose
3. Remote control
4. Batteries
5. Window Kit
6. Heat Clip Connector

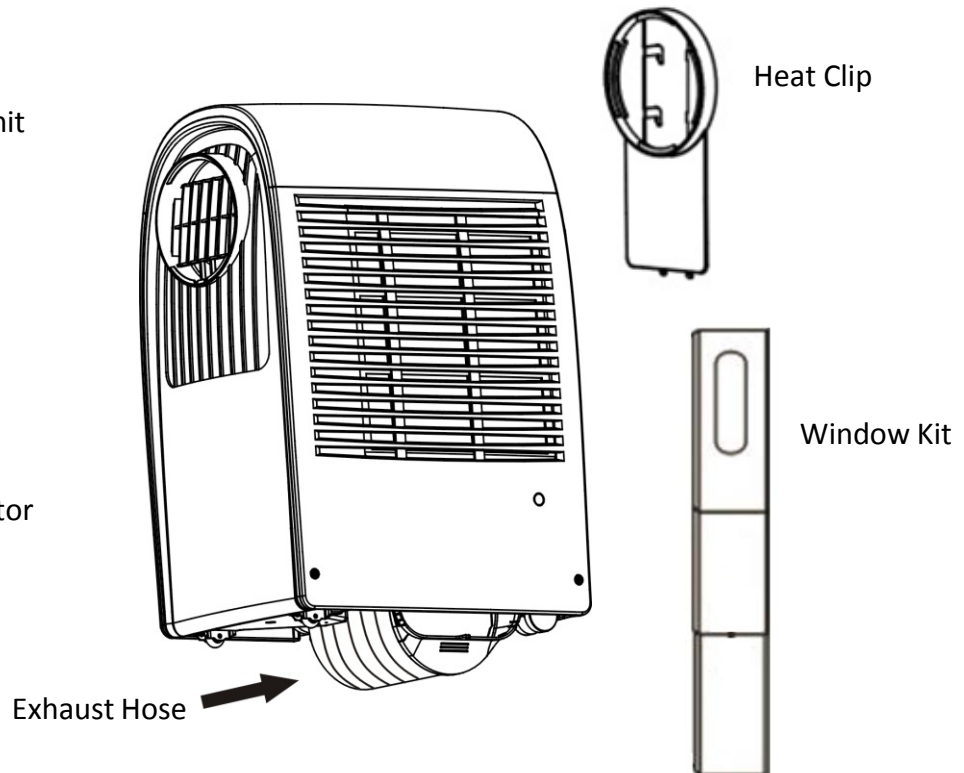

PARTS

1. Control panel
2. Remote control receiver
3. Hot air-outlet
4. Evaporator's filter
5. Cool air-inlet

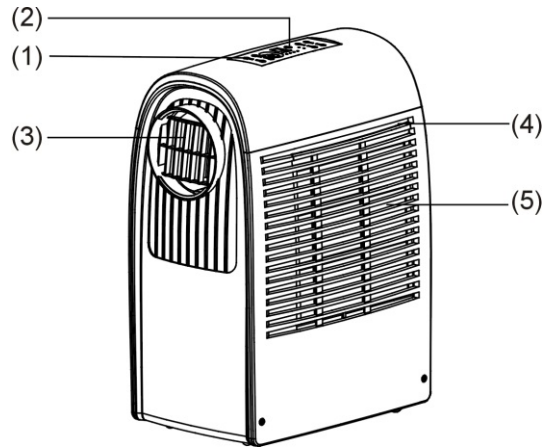

6. Air-outlet's joint part
7. Cool air-outlet
8. Condenser's filter
9. Hot air-inlet
10. Drain hole

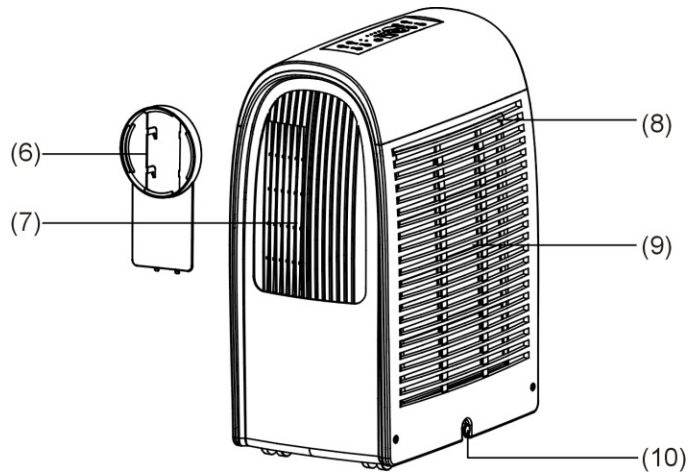

DISPLAY FUNCTIONS

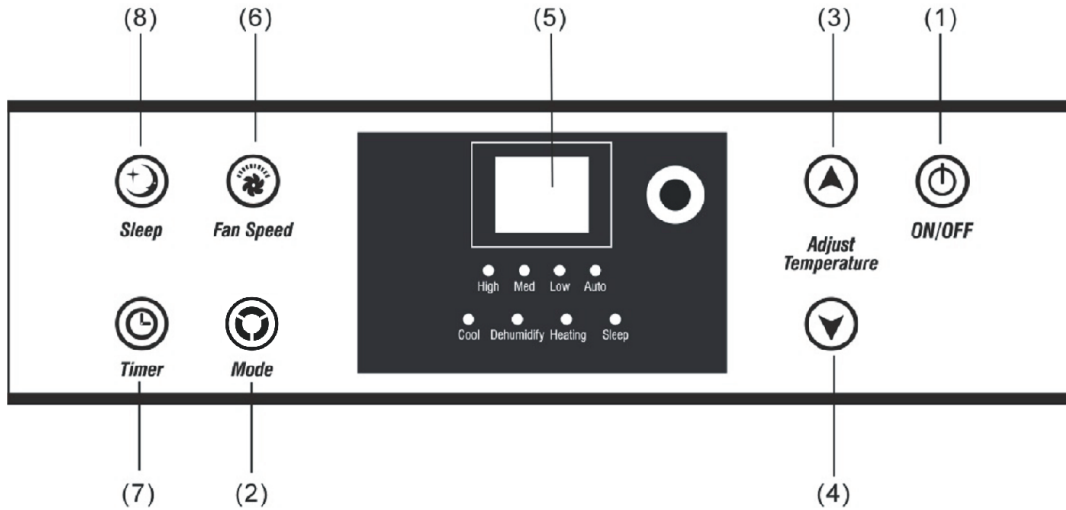

1. ON/OFF KEY

Press to turn unit "ON" or "OFF".

2. MODE

Press this key to select cooling, heating, or dehumidifying.

when the unit is not working, hold the function button for 10 seconds to change the temperature scale °C/°F.

3. TEMPERATURE REGULATION KEY (UP)

- During cooling function: This key raises the preset temperature by 1°F each time it is pressed and the maximum limit is 86°F.

- During heating function: This key raises the preset temperature by 1°F each time it is pressed and the maximum limit is 77°F.

4. TEMPERATURE REGULATION KEY (DOWN)

- During cooling function: This key lowers the preset temperature by 1°F each time it is pressed and the minimum limit is 63°F.

- During heating function: This key lowers the preset temperature by 1°F each time it is pressed and the minimum limit is 59°F.

5. L.E.D. DISPLAY

The display indicates the current setting temperature or the timer setting. When the set temperature or the timer is adjusted, the new setting is shown then the display returns the current set temperature.

✘ The display is also used to show error codes should a fault occur, see TROUBLE SHOOTING.

DISPLAY FUNCTIONS

6. FAN SPEED

Press to select either LOW, MEDIUM, HIGH or AUTO fan speed.

If "AUTO" is selected (During cooling function),"HIGH" or "MEDIUM" or "LOW" will be selected automatically according to the difference between setting temperature and ambient temperature.

Note: In heating function and dehumidifying function, this key is invalid because the unit is **defined** to be high speed in heating mode and low speed in dehumidifying mode.

7. PROGRAMMABLE TIMER

Programmable timer ON/OFF key.

TIMER-ON: The timer-on is used to turn on the unit automatically after the set time is over.

1. Press the "TIMER" key at stand-by status to set the time you desired.
2. Once the set hour has come to an end, the unit will turn on automatically.
3. Press the "POWER" key before the time out; the set time will be canceled and the unit will turn on.
4. You can set the function and fan speed while setting the timer.

TIMER-OFF: The timer-off is used to turn off the unit automatically after the setting time is over.

1. Press the "TIMER" key at operating status to set the time you desired.
2. Once the set hour has come to an end, the unit will turn off automatically.
3. Press the "POWER" key before the time out, the set time will be canceled and the unit will turn off.

DISPLAY FUNCTIONS

8. SLEEP CONTROL FUNCTION











In "Sleep" mode, your unit will automatically go into low fan speed allowing the temperature to slowly drift up (in cooling) or down (in heating). See below:

1. While in cooling mode, press the SLEEP key to set the temperature. It increases 2°F after an hour and at most increases 4°F after 2 hours.
2. While in heating mode, press the SLEEP key to set the temperature. It decreases 2°F after hour and at most decreases 4°F after 2 hours.
3. Press the SLEEP key again to cancel the setting.

9. ALARM

When the water tank is full, "E4" will be displayed on the display panel. To resume operation, please remove the rubber cap of the drain hose to drain out the water firstly. The E4 warning will disappear after draining, and then you can restart the unit by pressing the POWER key.

REMOTE CONTROL FUNCTIONS

Icon	Function
	Cooling
	Heating
	Dehumidifying
	Sleeping
	Timer ON/OFF
	Temperature
	Automatic air flow speed
	High speed
	Medium speed
	Low speed

Top view

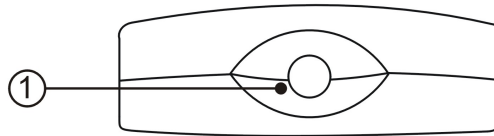

Front view

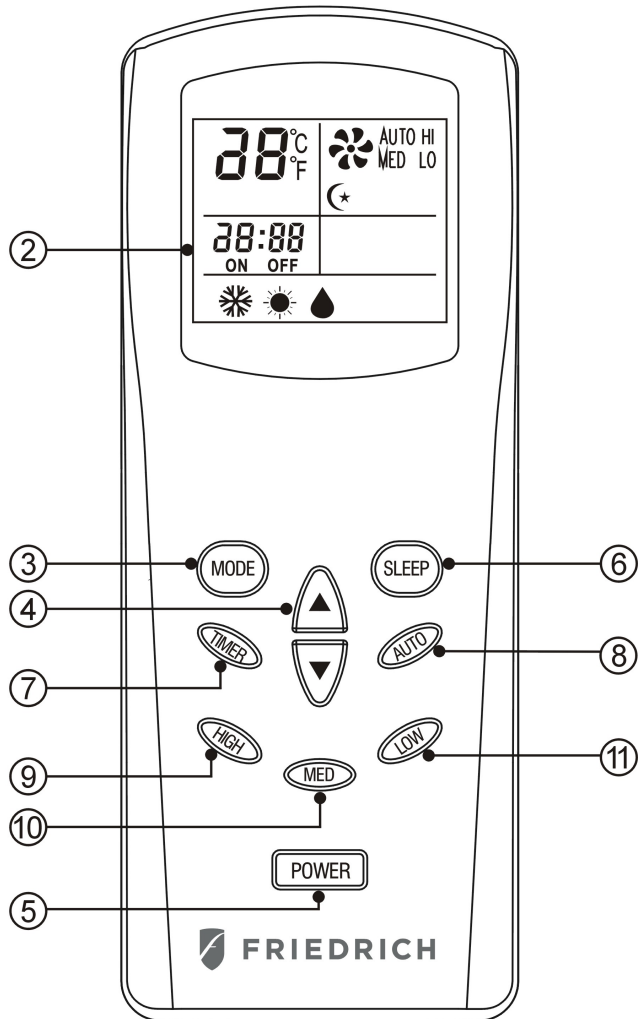

Instruction for the operating keys:

When a remote control signal is transmitted, a transmission icon on the display flashes once, indicating the signal has been transmitted.

REMOTE CONTROL FUNCTIONS

1. **Transmission window**

2. **Liquid crystal display**

3. **Mode select key:**

Select from among the three functions: cooling, heating and dehumidifying. The fast key function indicates the above operating modes in a cycle when the key is pressed without being released. However, the transmission icon will not appear until the key is released and the confirmed mode is transmitted.

4. **Setting keys for room temperature:**

The set temperature will rise by 1°F when the ▲ key is pressed once and the set temperature will fall by 1°F when the ▼ key is pressed once. Both keys have the fast key function and can make the set temperature rise or fall continuously when the keys are pressed without release.

5. **Power key:**

When this key is pressed, the memorized modes and other information about temperature, speed, direction of airflow, sleep, etc., in the remote control will be transmitted to the unit and it will operate correspondingly. When the key is pressed again, the main unit will stop immediately.

6. **Sleep key**

When this key is pressed, the air flow of the unit changes into sleep mode (low speed).

- (1) Press "SLEEP" key, set sleep function; press again, and cancel sleep setting.
- (2) The temperature will increase 2°F half an hour after setting sleep function, and will increase at most 4°F every two hours after that.
- (3) When the main power supply is cut off, the sleep function setting will be cancelled automatically.
- (4) When you turn off the unit, sleep function setting will be cancelled automatically.

REMOTE CONTROL FUNCTIONS

7. Timer key:

TIMER-ON: The timer-on is used to turn on the unit automatically after the setting time is over.

1. Press the "TIMER" key at stand-by status to set the time desired.
2. Once the set time has come to an end. The unit will turn on automatically.
3. Press the "POWER" key before time out, the setting time will be canceled and the unit will turn on.

TIMER-OFF: The timer-off is used to turn off the unit automatically after the set time is over.

1. Press the "TIMER" key at stand-by status to set the time desired.
2. Once the setting hour has come to an end. The unit will turn off automatically.
3. Press the "POWER" key before the time out, the set time will be canceled and the unit will turn off.

Note: Press "Timer" key when unit is off, The unit will be automatically Turn on, The setting method same as above

8. Auto key

Automatic fan speed

9. High key

High fan speed

10. Med key

Middle fan speed

11. Low key

Low fan speed

DRAIN PIPE

NOTICE

This unit can evaporate the condensation and distribute through the exhaust hose automatically.

1. The drain pipe doesn't have to be installed, when the unit is in cool mode. Please make sure that the rubber cap is locked on drain hole, when the unit is running.

2. When operating the heating function, the “①” rubber cap on drain hole should be pulled out and proper drain pipe should be installed in order to improve heating.

3. When operating the dehumidifying function the “①” rubber cap on drain hose should be pulled out and proper drain hose should be installed.

● Please remove the air exhaust hose, connect a drain hose to the drain hole and lead the water to the outside in order to intensify dehumidifying capacity.

※ When the water tank is full, "E4" will be displayed on the display panel. Please remove the rubber cap “①” of the drain hole to drain out the water first. After drainage is completed, please restart the unit so unit can operate normally.

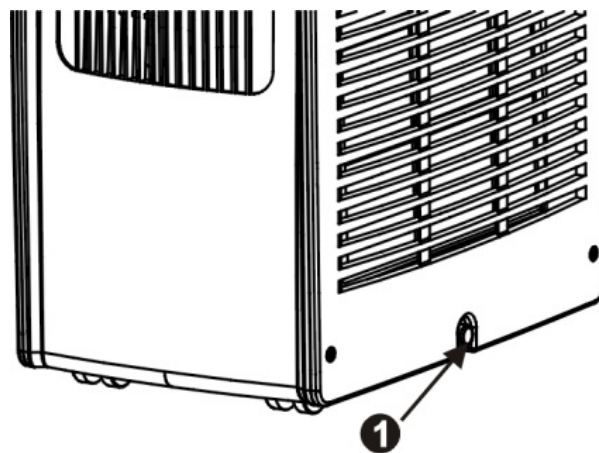

MAINTENANCE AND CLEANING



WARNING

ELECTRICAL SHOCK HAZARD

Disconnect all power before servicing or cleaning. Failure to follow these instructions can result in death, electrical shock or fire.

MAINTENANCE

PLEASE DISCONNECT THE POWER CORD BEFORE CLEANING.

AIR FILTER

The air filter located on the left hand side of the unit can be removed simply by pulling the frame up.



CAUTION

Clean the air filter with a vacuum cleaner ensuring all dust is removed.

CONDENSER/EVAPORATOR

Use a brush attachment with a vacuum cleaner.

CASING

Wipe with a damp cloth and polish with a soft cloth.

To remove the air filter, please follow the arrow direction and pull the filter lightly, and then take out the filter for cleaning.

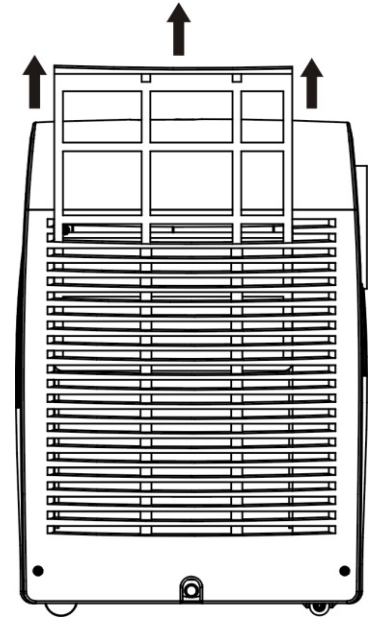

Safety Precautions



CAUTION

- Install in an accessible location.
- Only operate the unit in an upright position.
- Do not place in direct sunlight to avoid discoloration of the plastic.
- Do not use the unit on or in water to avoid electrical shock.
- Do not use near gas appliances, flammable liquids, or fires.

Power Sources



WARNING

- Make sure your electrical receptacle has the same configuration as your air conditioner's plug. If different, consult a Licensed Electrician.
- Do not use plug adapters.
Do not use an extension cord.
Do not remove ground prong.
- Always plug into a grounded 3 prong outlet. Failure to follow these instructions can result in death, fire, or electrical shock.

Other Warnings

- Do always keep the unit 3 feet away from TV sets or radios to avoid the risk of electromagnetic interference.
- Do always keep the air outlets free from obstructions.

INSTALLATION

PLACE FOR USE

1. Because the machine distributes hot air, please don't place or operate in a narrow place.
2. Do not work the machine in a humid place.
3. Don't place the machine in a sunlit corner otherwise the unit might shut down due to the overheat and the color of the machine may soon fade out.

HELPFUL HINTS

The unit is fitted with a special thermal cut off device.

Please ensure the unit is not placed against objects which will obstruct air intake e.g. furniture or curtains as this will affect its performance dramatically.

Do not overextend the exhaust hose beyond it's full extension or attach additional extensions.

EXHAUST HOSE INSTALL

1. To attach the flexible exhaust hose to the unit, rotate the hose clockwise (as shown in figure ①) directly onto the hot-air outlet ring .
2. To remove the flexible exhaust hose from the unit, rotate the hose counter-clockwise (as shown in figure ②) off of the hot-air outlet ring .

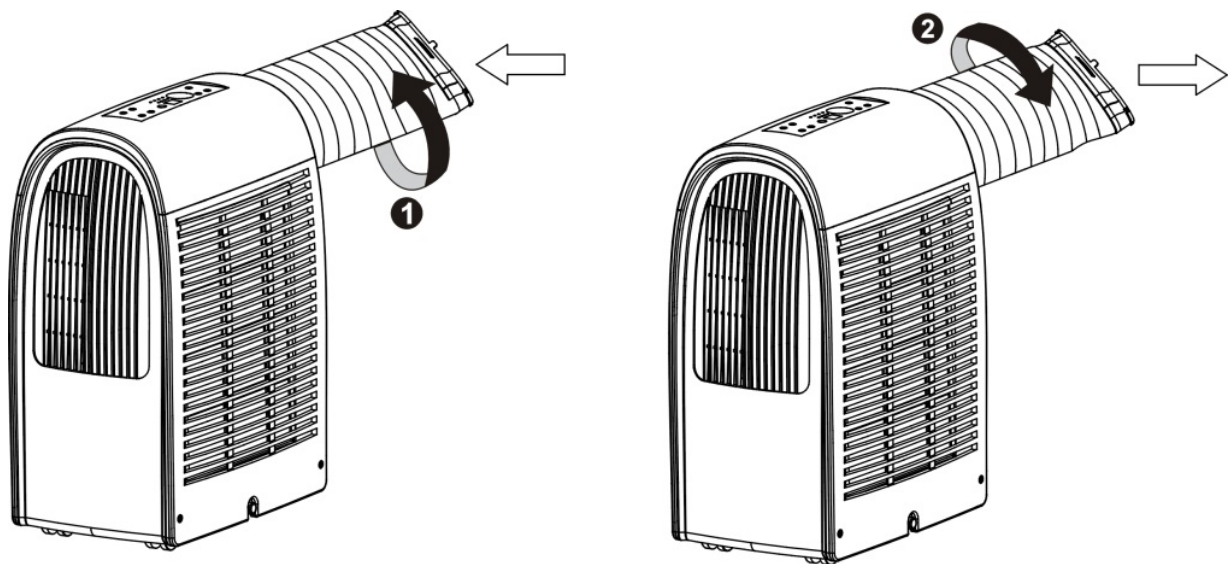

INSTALLATION

WINDOW KIT INSTALL

1. Install the Flexible Exhaust Hose and the Adjustable Window Slider Kit as depicted in Fig.1 & Fig.1a.

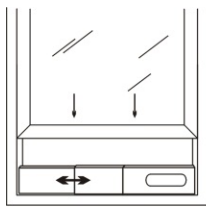

Window slider kit
min: 55cm
max: 100cm

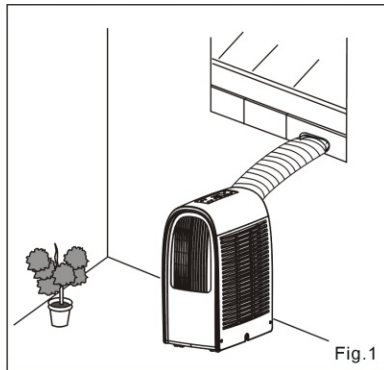
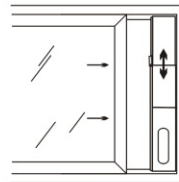

Fig.1



Window slider kit
min: 55cm
max: 100cm

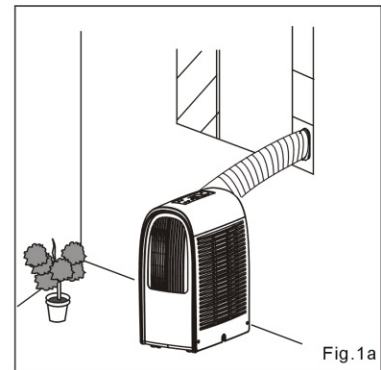

Fig.1a

How to enjoy heating function?

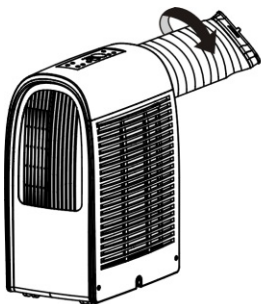

Fig.01

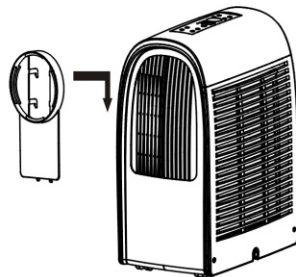

Fig.02

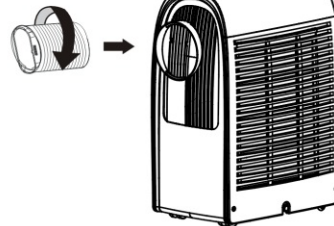

Fig.03

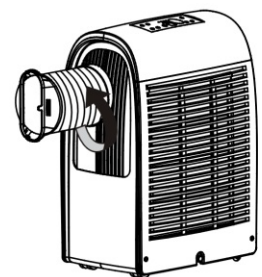

Fig.04

1. For heating function: remove the exhaust hose from the unit, as shown in "Fig.01".
2. As shown in "Fig.02", slide the heat clip connector onto the cooling outlet side of the unit.
3. As shown in "Fig.03", attach the exhaust hose directly onto the onto heat clip connector.
4. Rotate the hose clockwise, as shown in "Fig.04", directly onto the heat clip ring.
5. Now turn the unit around and feed hose through window, or other opening, as shown in "WINDOW KIT INSTALL" section above.

TROUBLESHOOTING

TROUBLE SHOOTING

Error Code	Cause	Troubleshooting
E1	Electrical short on both temperature sensor and PCB	Contact an electrician for repair
E2	Electrical short of temperature sensor copper tube and PCB wiring	Contact an electrician for repair
E4	Indicates water tank full or poor contact of signal plug.	User needs to pull out the rubber stopper which is located at the bottom of the unit, to drain the water away. Check that the plug has been wired correctly.

SPECIFICATION

Model No.	P08S	P10S
Power Source	120V~60Hz	
Cooling Capacity	8000BTU/H	10000BTU/H
Cooling Power Input	964W	1190W
EER	8.3	8.4
Amps	9A	11A
Moisture Removed	63.4 Pints/Day	84.5 Pints/Day
Refrigerant	R410A, 15.9 ozs (450g)	R410A, 18 ozs (510g)
Dimensions	11 1/3" W(288mm) x 16 6/7"D (428mm) x 25 1/5"H (640mm)	

(CE) N 842/2006: R410A is a kind of fluorinated greenhouse gases covered by the Kyoto Protocol.

Its total global warming potential (GWP) is 1975



This marking indicates that this product should not be disposed with other household wastes throughout the EU. To prevent possible hazards to the environment or human health from uncontrolled waste disposal, please recycle it to prove the sustainable reuse of material resources. Please ask return and collection systems or contact the retailer where the product was purchased to return your used device, they can recycle products safely.



Friedrich Air Conditioning Co.
 10001 Reunion Place • Suite 500 • San Antonio, TX • 78216
 (800) 541-6645
www.friedrich.com



F R I E D R I C H

1 8 8 3

Friedrich Air Conditioning Company
10001 Reunion Place, Suite 500
San Antonio, TX 78216

www.friedrich.com

PORTABLE AIR CONDITIONERS LIMITED WARRANTY

FIRST YEAR

ANY PART: If any part supplied by FRIEDRICH fails because of a defect in workmanship or material within twelve months from date of original purchase, FRIEDRICH will repair the product at no charge, provided the product is transported to a Friedrich Authorized Service Center for repair. ALL transportation charges are the sole responsibility of the owner. This remedy is expressly agreed to be the exclusive remedy within twelve months from the date of the original purchase.

SECOND THROUGH FIFTH YEAR

SEALED REFRIGERANT SYSTEM: If the Sealed Refrigeration System (defined for this purpose as the compressor, condenser coil, evaporator coil, reversing valve, check valve, capillary, filter drier, and all interconnecting tubing) supplied by FRIEDRICH in your Room Air Conditioner fails because of a defect in workmanship or material within sixty months from date of purchase, FRIEDRICH will pay a labor allowance and parts necessary to repair the Sealed Refrigeration System; **PROVIDED** FRIEDRICH will not pay the cost of diagnosis of the problem, removal, freight charges, and transportation of the air conditioner to and from the Service Agency, and the reinstallation charges associated with repair of the Sealed Refrigeration System. All such cost will be the sole responsibility of the owner. This remedy is expressly agreed to be the exclusive remedy within sixty months from the date of the original purchase.

APPLICABILITY AND LIMITATIONS: This warranty is applicable only to units retained within the Fifty States of the U.S.A., District of Columbia, and Canada. This warranty is not applicable to:

1. Air filters or fuses.
2. Products on which the model and serial numbers have been removed.
3. Products which have defects or damage which results from improper installation, wiring, electrical current characteristics, or maintenance; or caused by accident, misuse or abuse, fire, flood, alterations and/or misapplication of the product and/or units installed in a corrosive atmosphere, default or delay in performance caused by war, government restrictions or restraints, strikes, material shortages beyond the control of FRIEDRICH, or acts of God.

OBTAINING WARRANTY PERFORMANCE: Service will be provided by the **FRIEDRICH Authorized Dealer or Service Organization** in your area. They are listed in the Yellow Pages. If assistance is required in obtaining warranty performance, write to: Room Air Conditioner Service Manager, Friedrich Air Conditioning Co., 10001 Reunion Place, Suite 500, San Antonio, TX 78216.

LIMITATIONS: **THIS WARRANTY IS GIVEN IN LIEU OF ALL OTHER WARRANTIES. Anything in the warranty notwithstanding, ANY IMPLIED WARRANTIES OF FITNESS FOR PARTICULAR PURPOSE AND/OR MERCHANTABILITY SHALL BE LIMITED TO THE DURATION OF THIS EXPRESS WARRANTY. MANUFACTURER EXPRESSLY DISCLAIMS AND EXCLUDES ANY LIABILITY FOR CONSEQUENTIAL OR INCIDENTAL DAMAGE FOR BREACH OF ANY EXPRESSED OR IMPLIED WARRANTY.**

NOTE: Some states do not allow limitations on how long an implied warranty lasts, or do not allow the limitation or exclusion of consequential or incidental damages, so the foregoing exclusions and limitations may not apply to you.

OTHER: This warranty gives you specific legal rights, and you may also have other rights which vary from state to state.

PROOF OF PURCHASE: Owner must provide proof of purchase in order to receive any warranty related services.

All service calls for explaining the operation of this product will be the sole responsibility of the consumer.

All warranty service must be provided by an **Authorized FRIEDRICH Service Agency**, unless authorized by FRIEDRICH prior to repairs being made.