

This Owner's Manual is provided and hosted by [Appliance Factory Parts](#).

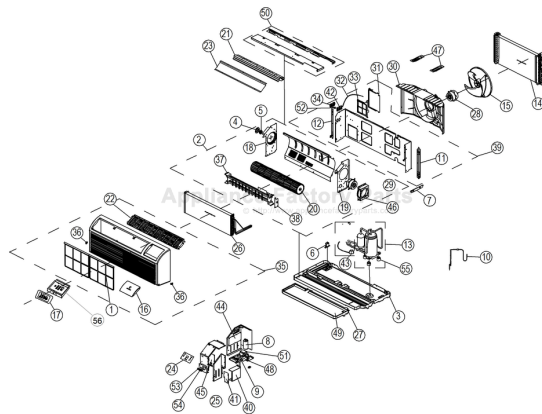

FRIEDRICH PDE07K3SF Owner's Manual

[Shop genuine replacement parts for FRIEDRICH
PDE07K3SF](#)



[Find Your FRIEDRICH Air Conditioner Parts - Select From 1575 Models](#)

----- Manual continues below -----



INSTALLATION & OPERATION GUIDE

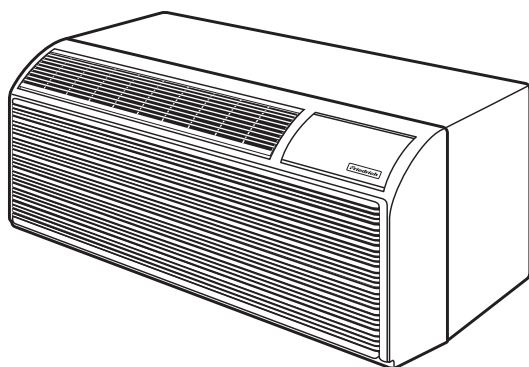

920-087-06 (4-08)

PTAC

PACKAGED TERMINAL AIR CONDITIONERS & HEAT PUMPS

Standard Control
Remote Thermostat
Seacoast Protected

Table of Contents

Your Safety and the safety of others	2
Unit Components	3
Model Number Code	4
Installation Recommendations	5
Friedrich Digital Control Features	6-7
Drain Kit Installation	8-9
Wall Sleeve Installation	10-11
Deep Wall Installation.....	12
Standard Grille Installation	13
Electrical Rating Tables.....	14
Power Cord Information	14
Installation Checklist.....	15
Chassis Installation	15-16
Digital Control User Input Configuration	17
Operation.....	18
Remote Control Operating Range.....	19
Remote Thermostat and Low Voltage Control Connections.....	20
Desk Control Terminals	21
Auxiliary Fan Control	21
Fresh Air Vent Control	21
Air Discharge Grille	21
Start-up Checklist.....	22
Appendix A: Electrical Wiring for 265 V Models	23
Routine Maintenance.....	24
Basic Troubleshooting Techniques.....	25
Digital Control Diagnostics and Test Mode.....	26
Accessories	27-28
Warranty	29

Your safety and the safety of others are very important.

We have provided many important safety messages in this manual and on your appliance. Always read and obey all safety messages.



This is a safety Alert symbol.

This symbol alerts you to potential hazards that can kill or hurt you and others.

All safety messages will follow the safety alert symbol with the word "WARNING" or "CAUTION". These words mean:

! WARNING

You can be killed or seriously injured if you do not follow instructions.

! CAUTION

You can receive minor or moderate injury if you do not follow instructions.

All safety messages will tell you what the potential hazard is, tell you how to reduce the chance of injury, and tell you what will happen if the instructions are not followed.

NOTICE

A message to alert you of potential property damage will have the word "NOTICE". Potential property damage can occur if instructions are not followed.

Typical Unit Components

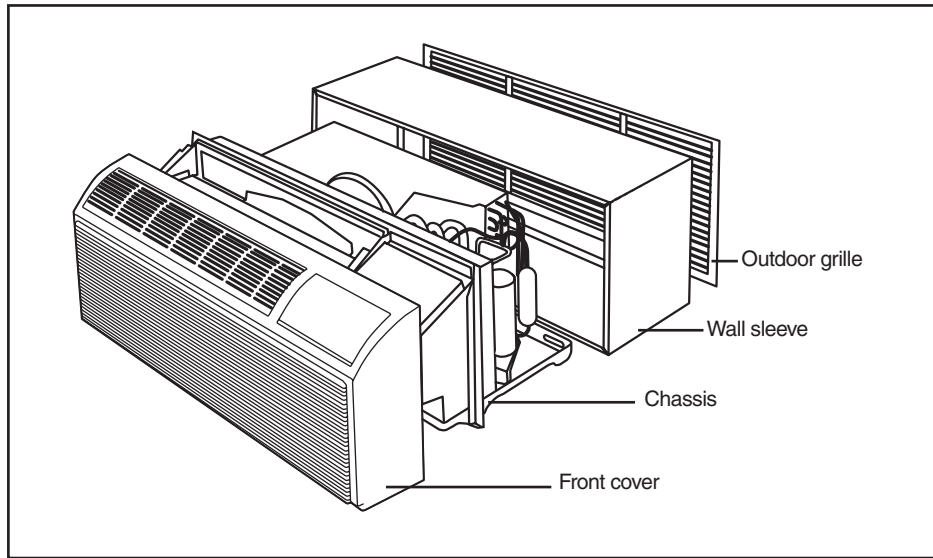

Thank you for your decision to purchase the newly designed Friedrich Packaged Terminal Air Conditioner (PTAC). We are confident that you will find this unit a quiet and efficient example of Friedrich reliability.

This Installation and Operation Manual has been designed to insure maximum satisfaction in the performance of your unit. For years of trouble-free service, please follow the installation instructions closely. We cannot overemphasize the importance of proper installation. We have added new information to the basic instructions to help you achieve success.

Remember, proper installation is not difficult but it is essential.

Model Number Code

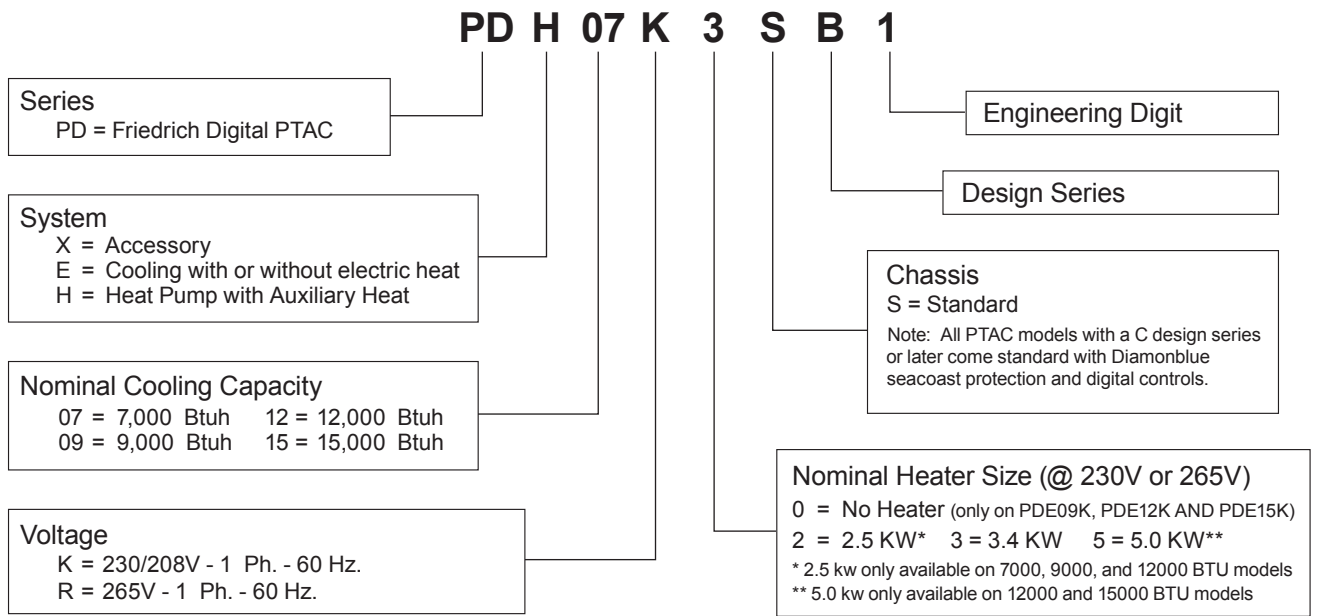

WARNING

Please read this manual thoroughly prior to equipment installation or operation. It is the installer's responsibility to properly apply and install the equipment. Installation must be in conformance with the NFPA 70-2008 National Electric Code or current edition and Uniform Mechanical Code current edition and applicable local or national codes.

Failure to do so can result in property damage, personal injury and/or death.

PTAC Installation Recommendations

For proper PTAC unit performance and maximum operating life please refer to the minimum installation clearances below:

Figure 1

PTAC units should be installed no closer than 12" apart when two units are side by side. If three or more PTAC units are to operate next to one another allow a minimum of 36" between units. Also, a vertical clearance of 60" should be maintained between units installed.

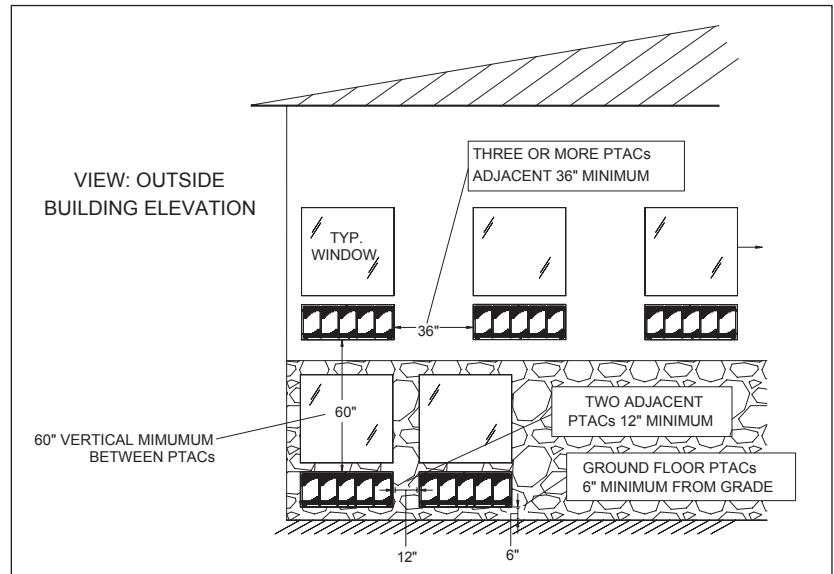
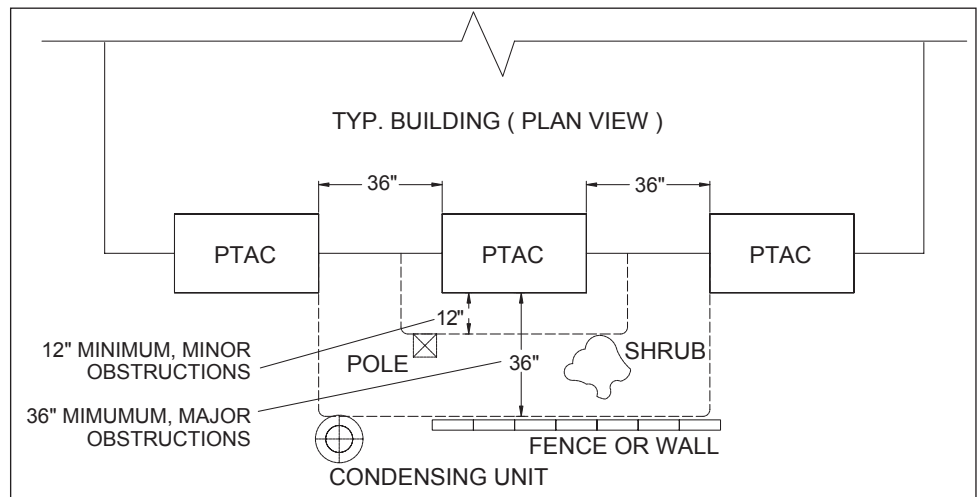

Figure 2

For PTACs on the ground floor or anytime obstructions are present, use the following guidelines:

- For minor obstructions such as lamp poles or small shrubbery a clearance of 12" from the outdoor louver should be maintained.
- For major obstructions such as a solid fence, wall or other heat rejecting device like a condensing unit, a minimum distance of 36" should be kept.



The above suggestions are for reference only and do not represent all possible installations. Please contact the factory for information regarding affects of other installation arrangements. By following these simple recommendations you can be confident that your Friedrich PTAC will provide years of worry free operation.

Friedrich Digital Control Features

The new Friedrich digital PTAC has state of the art features to improve guest comfort, indoor air quality and conserve energy. Through the use of specifically designed control software for the PTAC industry Friedrich has accomplished what other Manufacturer's have only attempted – a quiet, dependable, affordable and easy to use PTAC.

Below is a list of standard features on every Friedrich PTAC and their benefit to the owner.

Digital Temperature Readout	By digitally monitoring desired room temperature the room is controlled more precisely than conventional systems. The large, easy to read LED display can show either set-point or actual room temperature as selected by owner.
One-Touch Operation	When the unit is powered off the unit can be returned directly to heating or cooling mode by pressing the 'Heat' or 'Cool' buttons without the confusing power up sequence of some controls. One-touch control takes guesswork out of unit control delivering a more enjoyable experience and eliminating front-desk calls.
Individual Mode and Fan Control Buttons	By having separate control buttons and indicators for both fan and mode settings the Friedrich digital control eliminates the confusion of previous digital PTACs. The accurate temperature setting provides greater guest comfort than other systems.
Quiet Start/Stop Fan Delay	The fan start and stop delays prevent abrupt changes in room acoustics due to the compressor energizing or stopping immediately. Upon call for cooling or heating the unit fan will run for five seconds prior to energizing the compressor. Also, the fan off delay allows for "free cooling" by utilizing the already cool indoor coil to its maximum capacity by running for 30 seconds after the compressor.
Remote Thermostat Operation	Some applications require the use of a wall mounted thermostat. All new Friedrich PTACs may be switched from unit control to remote thermostat control easily without the need to order a special model or accessory kit.
Wireless Remote Control Ready	Guests can adjust the temperature and mode of the unit through the use of an optional hand held wireless remote, improving guest comfort and relaxation.
Internal Diagnostic Program	The new Friedrich digital PTAC features a self diagnostic program that can alert maintenance to component failures or operating problems. The internal diagnostic program saves properties valuable time when diagnosing running problems.
Service Error Code Storage	The self diagnosis program will also store error codes in memory if certain conditions occur and correct themselves such as extreme high or low operating conditions or activation of the room freeze protection feature. Storing error codes can help properties determine if the unit faced obscure conditions or if an error occurred and corrected itself.
Constant Comfort Room Monitoring	The on-board processor monitors time between demand cycles (heat or cool) and will cycle the fan every 9 minutes to sample the room condition and determine if the desired conditions are met. This allows the room to have similar benefits to a remote mounted stat without the complication or cost of a wall mounted thermostat.
Electronic Temperature Limiting	By limiting the operating range the property can save energy by eliminating "max cool" or "max heat" situations common with older uncontrolled systems. The new electronic control allows owners to set operating ranges for both heating and cooling independently of one another.
Room Freeze Protection	When the PTAC senses that the indoor room temperature has fallen to 40°F the unit will cycle on high fan and the electric strip heat to raise the room temperature to 46°F then cycle off again. This feature works regardless of the mode selected and can be turned off. The control will also store the Room Freeze cycle in the service code memory for retrieval at a later date. This feature ensures that unoccupied rooms do not reach freezing levels where damage can occur to plumbing and fixtures.
Random Compressor Restart	Multiple compressors starting at once can often cause electrical overloads and premature unit failure. The random restart delay eliminates multiple units from starting at once following a power outage or initial power up. The compressor delay will range from 180 to 240 seconds.
Digital Defrost Thermostat	The new Friedrich PTAC uses a digital thermostat to accurately monitor the outdoor coil conditions to allow the heat pump to run whenever conditions are correct. Running the PTAC in heat pump mode saves energy and reduces operating costs. The digital thermostat allows maximization of heat pump run time.

Friedrich Digital Control Features Continued

Instant Heat Heat Pump Mode	Heat pump models will automatically run the electric heater to quickly bring the room up to temperature when initially energized, then return to heat pump mode. This ensures that the room is brought up to temperature quickly without the usual delay associated with heat pump units.
Even Heat Monitoring	The digital control monitors indoor conditions to ensure that the room temperature is within five degrees of the setpoint. If necessary the unit will cycle the electric heat to maintain the temperature. This feature ensures guest comfort by delivering the heating benefits of an electric heater while maintaining the efficiency benefits of a heat pump.
Fan Cycle Control	The owner may choose between fan cycling or fan continuous mode based on property preference. (Note: Even heat monitoring and quiet start/stop fan delay only operate in fan cycle mode) Fan continuous mode is used to keep constant airflow circulation in the room during all times the unit is 'ON'. Fan cycle will conserve energy by only operating the fan while the compressor or electric heater is operating.
Emergency Heat Override	In the event of a compressor failure in heat pump mode the compressor may be locked out to provide heat through the resistance heater. This feature ensures that even in the unlikely event of a compressor failure the room temperature can be maintained until the compressor can be serviced.
Desk Control Ready	All Friedrich digital PTACs have low voltage terminals ready to connect a desk control energy management system. Controlling the unit from a remote location like the front desk can reduce energy usage and requires no additional accessories at the PTAC.
Indoor Coil Frost Sensor	The frost sensor protects the compressor from damage in the event that airflow is reduced or low outdoor temperatures cause the indoor coil to freeze. When the indoor coil reaches 30°F the compressor is disabled and the fan continues to operate based on demand. Once the coil temperature returns to 45°F the compressor returns to operation.
Ultra-Quiet Air System	The new Friedrich PD series units feature a indoor fan system design that reduces sound levels without lowering airflow and preventing proper air circulation.
High Efficiency	The Friedrich PTAC benefits from quality components and extensive development to ensure a quiet, efficient and dependable unit.
Single Motor	Friedrich's single-motor design allows for enhanced outdoor airflow and simplifies the unit design without the need for redundant components.
Rotary Compressor	High efficiency rotary compressors are used on all Friedrich PTACs to maximize durability and efficiency.
Auxiliary Fan Ready	The Friedrich PTAC features a 24V AC terminal for connection to an auxiliary fan that may be used to transfer air to adjoining rooms. Auxiliary fans can provide conditioning to multiple rooms without the requirement of multiple PTAC units.
Aluminum Endplates	All Friedrich PTACs are built with .04" endplates made from aluminum as opposed to steel. The endplates are typically the most susceptible area for corrosion and aluminum is far more resistant to corrosion than even coated steel.
Diamonblue Technology	Diamonblue (seacoast protection) protects the outdoor coil from harsh environments. Comes standard on all PTAC units.
Top Mounted Anti-microbial Air Filters	All Friedrich PTAC return air filters feature an anti-microbial element that has proven to prevent mold and bacterial growth in laboratory testing. PDXFT replacement filter kits feature the same anti-microbial agent. All filters are washable and reusable and are easily accessed from the top of the unit without the removal of the front cover.
Filtered Fresh Air Intake	Friedrich PTAC units are capable of introducing up to 70 CFM of outside air into the conditioned space. The outdoor air passes through a mesh screen to prevent debris from entering the airstream.

Installation Instructions PXDR10 Drain Kit

NOTE: Determine whether drain will be located within the wall, on the indoor side, or will drain to the exterior of the building. Follow appropriate instructions below depending on your particular type of installation.

Internal Drain (optional for new construction)

NOTE: If installing an internal drain, you MUST install a drain kit on the wall sleeve before the wall sleeve is installed.

1. Refer to Figure 3 below and locate the drain within the "Primary" area for best drainage. Maintain at least a 1/2" clearance from the embossed area.
2. Using the mounting plate with the 1/2" hole as a template, mark and drill two, 3/16" mounting holes and a 1/2" drain hole.
3. Remove the backing from the gasket and mount it on the flat side of the mounting plate. (See Figure 4.) Insert the drain tube through the hole in the gasket and mounting plate so the tube flange will be against the wall sleeve.
4. Position the assembly beneath the drilled holes and secure it with #10-24 x 1/2" machine screws and lock nuts provided. Seal the tops of the screws with silicone caulking.
5. Use 1/2" I.D. copper tube, PVC pipe, or vinyl hose (obtained locally) to connect the internal drain tube to the drain system in the building.
6. Referring to Detail A on page 9, locate and assemble the (2) two cover plates and gaskets over the drain holes at the rear of the wall sleeve. Attach them with the #10 sheet metal screws provided. Make certain that the four overflow slots at the rear of the wall sleeve are not blocked (See drawing of the back of the sleeve on page 9).
7. If a deep wall extension (PXWE) is used, after installing the field supplied flashing, caulk as required. Be sure to caulk around the flashing and the wall sleeve where the hole was drilled for the drain tube.

Figure 3
Drain Kit Location and Installation

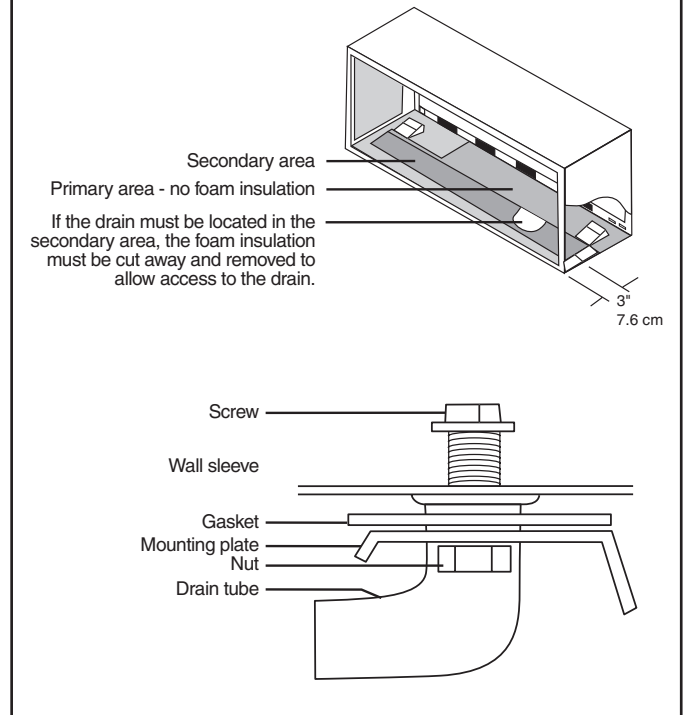

External Drain (for new construction or unit replacement)

When using an external drain system, the condensate is removed through either of two drain holes on the back of the wall sleeve. Select the drain hole which best meets your drainage situation and install the drain kit. Seal off the other with a cover plate.

Drain Tube Installation

1. Peel the backing tape off the gaskets and apply the sticky side to one cover plate and one mounting plate as shown in Details A and B.
2. Place the drain tube through the gasket and the mounting plate with the flange toward the wall sleeve.
3. Attach the drain tube assembly to one of the two drain holes at the rear of the wall sleeve. The large flange on the mounting plate is positioned at the bottom of the sleeve facing toward the sleeve, Detail B. When the drain tube is positioned at the desired angle, tighten the screws.

NOTICE

If the wall sleeve has not been installed, the drain tube must be rotated to a horizontal position until after the sleeve is installed. Tighten the mounting plate screws when the tube is in the proper position. Make certain that the four overflow slots at the rear of the wall sleeve are not blocked. (See the drawing below.)

Potential property damage can occur if instructions are not followed.

Cover Plate Installation

4. Mount the foam gasket to the cover plate. Using two #10 x 1/2" sheet metal screws (provided), attach the cover plate to the remaining drain hole. Make certain the large flange on the plate is positioned at the bottom of the sleeve.
5. Discard the additional cover plate, gasket, machine screws, and locknuts.

PXDR10	
QUANTITY	DESCRIPTION
2	COVER PLATES
1	MOUNTING PLATE
1	DRAIN TUBE
3	MOUNTING PLATE GASKETS
4	#10 x 1/2" MOUNTING SCREWS
2	10-24 x 1/2" MACH. SCREWS
2	LOCKNUTS

Figure 4

Drain Kit Installation

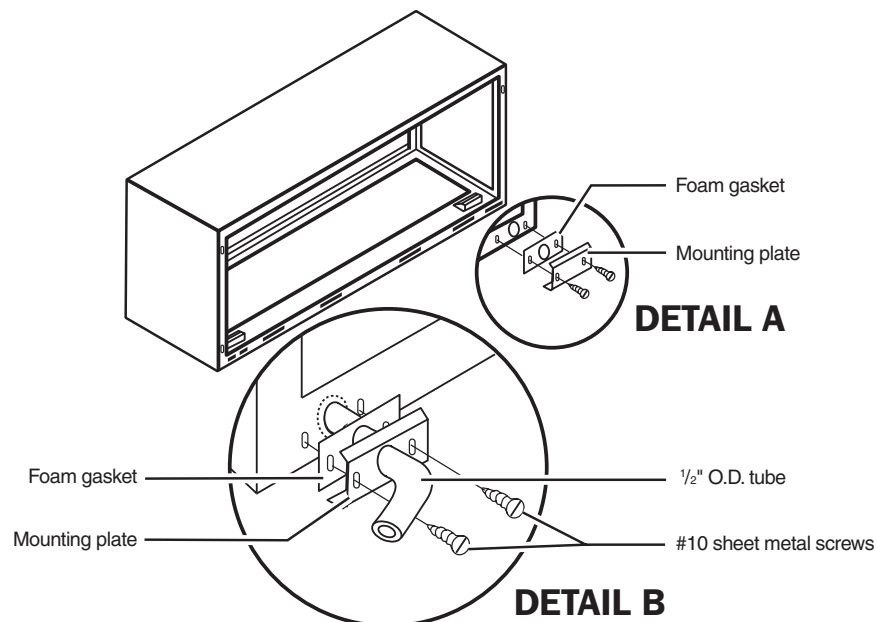

NOTES:

The large flange on the mounting plate is positioned at the bottom of the sleeve facing toward the sleeve. The drain tube must be rotated to a horizontal position to allow for the wall sleeve to be installed into the wall. Once the wall sleeve is installed, return the drain tube to a downward angle.

WARNING**Falling Object Hazard**

Not following Installation Instructions for mounting your air conditioner can result in property damage, injury, or death.



Wall Sleeve Installation Instructions (PDXWS)

NOTE: Insure that the unit is only installed in a wall structurally adequate to support the unit including the sleeve, chassis and accessories. If the sleeve projects more than 8" into the room, a subbase or other means of support MUST be used. Please read these instructions completely before attempting installation.

Figure 5

Typical Wall Sleeve Installation

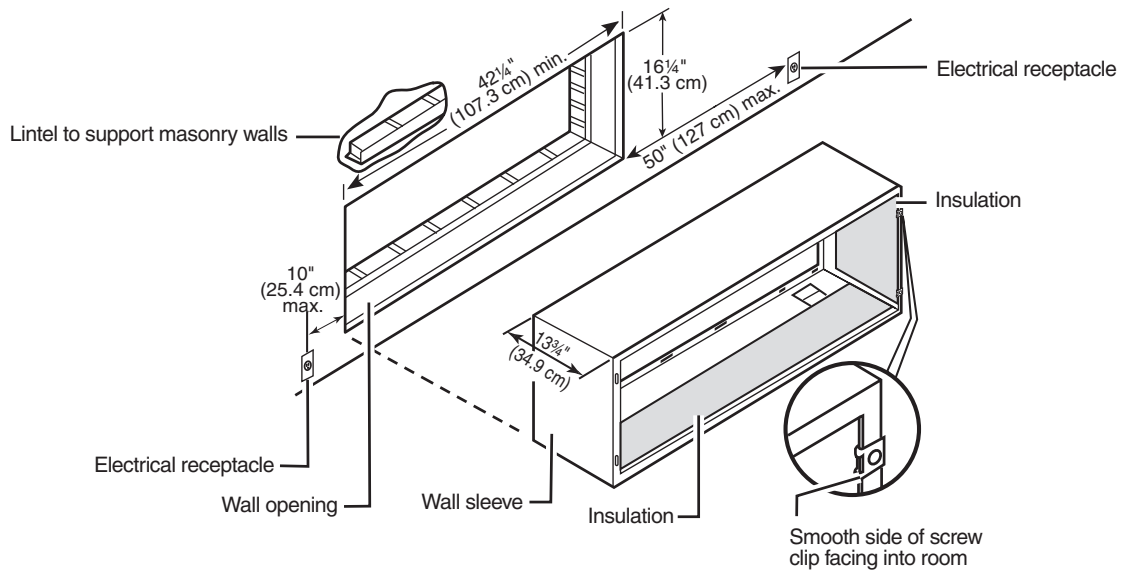

Note: All 230/208V units are manufactured with a 60" power cord. The receptacle locations above must be followed to ensure proper connections.

For Deep Wall Installation See Section II

The following instructions apply ONLY to walls less than 13 1/4" in depth.

1. From inside the building, position the wall sleeve in the opening and push it through the wall so it protrudes at least 1/4" on the outside, note Figure 5.
2. Position the wall sleeve with a slight tilt towards the outside to facilitate condensate drainage. It should be level side-to-side and the front should be 1/4" bubble higher than the back.

NOTICE DO NOT allow any pitch toward the inside. Potential property damage can occur if instructions are not followed.

WARNING

Electrical shock hazard.

Turn electric power OFF at the fuse box or service panel before making any electrical connections and ensure a proper ground connection is made before connecting line voltage. Failure to do so can result in property damage, personal injury and/or death.

Figure 6
Dimensions

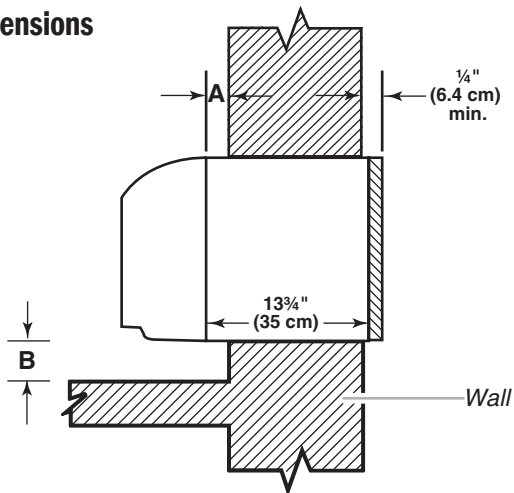

Dimension*	A	B	
	Allow for wall finishing (Minimum)	Allow for floor finishing Min.	Max
No Accessories	1/4" (6.4 mm)*	1/4" (6.4 mm)	---
With Subbase	1 3/4" (4.5 cm)	3 1/2" (8.9cm)	5" (12.7cm)
With Lateral Duct	3/4" (1.9 cm)	1/4" (6.4 mm)	---

* If more than one accessory is to be used, use the maximum dimension. If the wall thickness is more than 13 3/4" (35cm) - (A + 1/4" [6.4 mm]), a sleeve extension must be used.

- Drill two 3/16" holes through each side of the sleeve approximately 4" from top and 4" from bottom of sleeve. Screw four #10 x 1" screws (included) or appropriate fasteners for your installation, through the holes in the sides of the wall sleeve.
- Apply sealant around the wall sleeve where it projects through the inside and outside wall surfaces. Apply the sealant to the screw heads or the tops of the fasteners used in Step #3.
- If the chassis and exterior grille are to be installed later, leave the weatherboard and center support in place, otherwise remove and dispose of them.
- Provide a support lintel if the wall sleeve is installed in a concrete or masonry wall. (See Figure 7.)

NOTICE When sealing the sleeve on the outside of the building, be careful NOT to let the sealant block the two condensate drain holes or the four overflow slots at the bottom flange of the sleeve.

Potential property damage can occur if instructions are not followed.

Figure 7
Lintel Installation

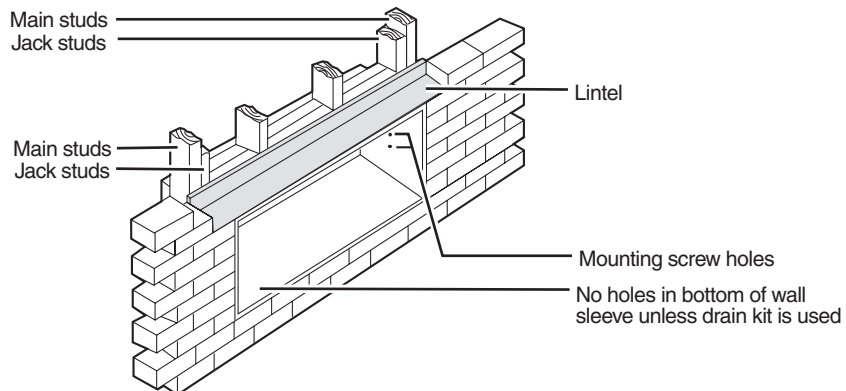

NOTE: Construct wall opening to comply with all applicable building codes.

Deep Wall Installation (PXWE)

If the wall is thicker than allowed in the notes in Figure 6, a sheet metal wall sleeve extension or custom deep wall sleeve and flashing **MUST** be used.

Installation Instructions for the PXWE

4" Wall Sleeve Extension

The following points **MUST** be considered when installing a wall sleeve extension:

1. Provision must be made to direct excess condensate from the back of the wall sleeve into the extension then outside the building or to a drainage system.
2. Air baffles must be mounted to properly direct air flow to and from the condenser.
3. The wall sleeve extension design must allow for the proper mounting of the grille.
4. Caulking is required at all sites where condensate or external water could potentially infiltrate into the building.
5. Fabricate and install metal flashing in wall to serve as a drip panel. Refer to drawing for more information.

6. Condensate notches and overflow slots must be kept clear of sealant and gaskets so condensate can flow freely into the wall sleeve extension.

NOTICE

Potential property damage can occur if instructions are not followed. In Addition, improper field fabrication or improper installation of wall sleeve extension will impact PTAC performance.

Extension Installation

Secure the wall sleeve extension to the wall sleeve before installing it in the wall. Refer to Figure 8 for a guide for fabrication of a condensate drip panel. The panel **MUST** extend the full depth of the wall sleeve and the wall sleeve extension.

Pay particular care in sealing and caulking the panel where it makes contact with the wall sleeve (see Figure 8). After installation in the wall, secure with fasteners through the sides. Use a good grade of silicone sealant around the sleeve extension. Seal all exposed screw heads. When the installation is complete, the outside grille should be attached to the wall sleeve extension.

Figure 8

Wall Sleeve Extension Sealant Locations

A

IMPORTANT NOTE: The silicone bead **MUST** extend 3" up the side of the two flanges to prevent condensate from leaking.

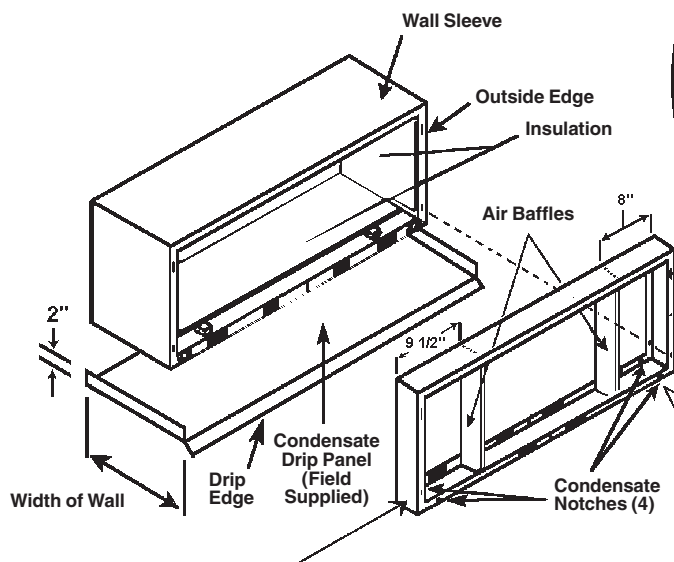

Wall Sleeve Extension, 42" X 16" Frame, 20 gauge minimum, painted or aluminium

SEALANT LOCATIONS

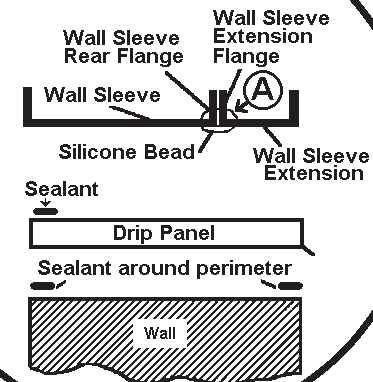

Sealant inside (4) bottom corners

Installation Instructions Model PXGA Standard Grille

1. Remove the center support and weatherboard if still installed in the sleeve.
2. Insert six plastic grommets into the grille openings from the outside of the grille as shown in Figure 9.
3. Insert two #8 x 3/8" sheet metal screws (provided) in the top two outside edge plastic grommets, and tighten them half way into the grommets.
4. Grasp the grille by the attached plastic handles. Position it with the condensate drain knockouts facing down. From inside the building, maneuver the grille through the wall sleeve and pull toward you until the screw heads are inserted into the keyhole slots at the top of the wall sleeve. Tighten the two screws completely.
5. Insert the remaining screws into the remaining holes and tighten securely.

⚠ WARNING

Falling Object Hazard

A safety line should be attached to the grille and an anchor point inside the building during installation. Property damage, injury or death can occur by grilles falling from a building during installation.



Figure 9
Standard Grille

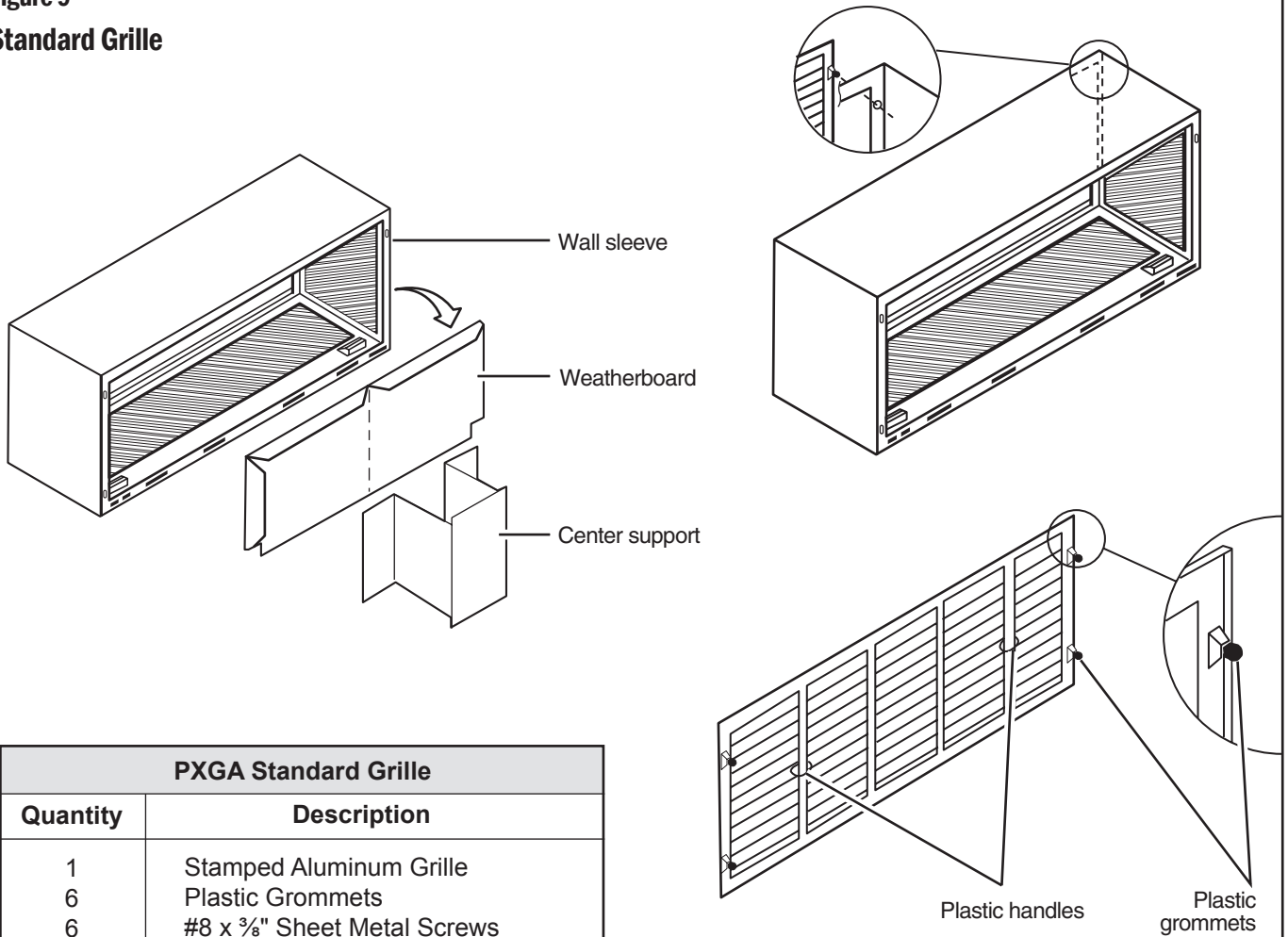



PXGA Standard Grille	
Quantity	Description
1	Stamped Aluminum Grille
6	Plastic Grommets
6	#8 x 3/8" Sheet Metal Screws

A. Electrical Rating Tables

All 230/208 volt units are equipped with power cords. See Appendix A on page 23 for wiring instructions on 265V units.

NOTE: Use Copper Conductors ONLY. Wire sizes are per NEC, check local codes for overseas applications.

AMPS	15	20*	30
RECEPTACLE			
TIME-DELAY TYPE FUSE (or HACR circuit breaker)	15	20	30

HACR – Heating, Air Conditioning, Refrigeration
 * May be used for 15 Amp applications if fused for 15 Amp
 NOTE: 265 volt units are hard wired.

NAMEPLATE / MAXIMUM CIRCUIT BREAKER SIZE	AWG WIRE SIZE**
15	14
20	12
30	10

AWG – American Wire Gauge
 * Single circuit from main box
 ** Based on copper wire, single insulated conductor at 60°C

WIRE SIZE	Use ONLY wiring size recommended for single outlet branch circuit.
FUSE/CIRCUIT BREAKER	Use ONLY type and size fuse or HACR circuit breaker indicated on unit's rating plate. Proper current protection to the unit is the responsibility of the owner. NOTE: A time delay fuse is provided with 265V units.
GROUNDING	Unit MUST be grounded from branch circuit through service cord to unit, or through separate ground wire provided on permanently connected units. Be sure that branch circuit or general purpose outlet is grounded. The field supplied outlet must match plug on service cord and be within reach of service cord. Refer to Table 1 for proper receptacle and fuse type. Do NOT alter the service cord or plug. Do NOT use an extension cord.
RECEPTACLE	The field supplied outlet must match plug on service cord and be within reach of service cord. Refer to Table 1 for proper receptacle and fuse type. Do NOT alter the service cord or plug. Do NOT use an extension cord.
WIRE SIZING	Use recommended wire size given in Table 2 and install a single branch circuit. All wiring must comply with local and national codes. NOTE: Use copper conductors only.

WARNING



ELECTRIC SHOCK HAZARD! Turn off electric power before service or installation. All electrical connections and wiring **MUST** be installed by a qualified electrician and conform to the National Electrical Code and all local codes which have jurisdiction. Failure to do so can result in property damage, personal injury and/or death.

B. Power Cord Information (230/208V models only)

All Friedrich 230/208V PTAC units are shipped from the factory with a Leakage Current Detection Interrupter (LCDI) equipped power cord. The LCDI device meets the UL and NEC requirements for cord connected air conditioners effective August 2004.

To test your power supply cord:

1. Plug power supply cord into a grounded 3 prong outlet.
2. Press RESET.
3. Press TEST (listen for click; Reset button trips and pops out).
4. Press and release RESET (listen for click; Reset button latches and remains in). The power supply cord is ready for operation.

NOTE: The LCDI device is not intended to be used as a switch.

Once plugged in the unit will operate normally without the need to reset the LCDI device. If the LCDI device trips and requires resetting the cause of the trip should be identified prior to further use of the PTAC.

If the device fails to trip when tested or if the power supply cord is damaged it must be replaced with a new supply cord obtained from the product manufacturer, and must not be repaired.

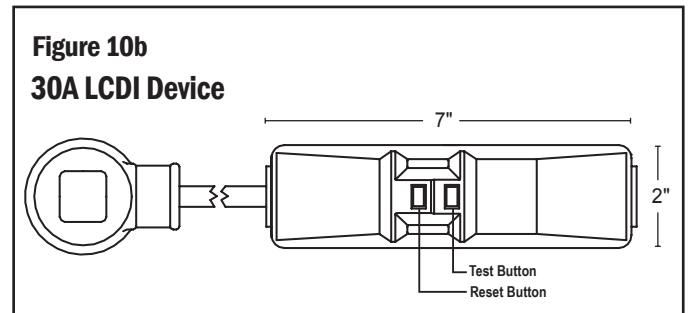
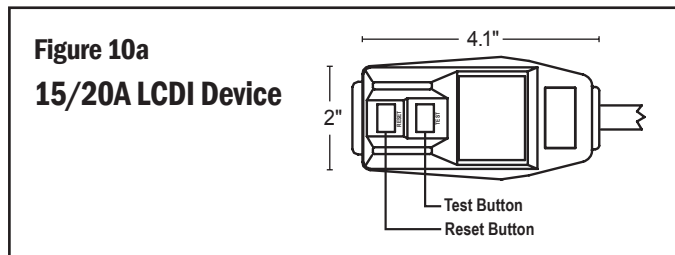

Installation Checklist

- Inspect all components and accessories for damage before and after installation.
- Remove the cardboard wall sleeve support and grille weatherboard.
- Check for proper wall sleeve installation in accordance with the wall sleeve installation instructions.
- Check for a subbase kit or other means of structural support which is required for ALL installations projecting more than 8" into room.
- Install the recommended Condensate Drain Kits for complete condensate removal.
- Ensure that the chassis is installed in a 16" high x 42" wide wall sleeve that is no deeper than 13 3/4". A baffle kit is required if the sleeve exceeds that depth.
- Ensure that drapes, bed, bedspread, furniture, etc. DO NOT block either return or discharge air grilles.
- Inspect the condenser air inlet and outlet for any obstructions (shrubby, etc.)
- Ensure that 'reset' button is pressed on LCD device (only on cord connected models)

Section III – Chassis Installation

Check to be sure the wall sleeve, extension (if used), grille, and drain kit are installed properly before chassis installation.

1. Remove the weatherboard and center support from the sleeve (if still in place). Be sure an outdoor grille is attached.

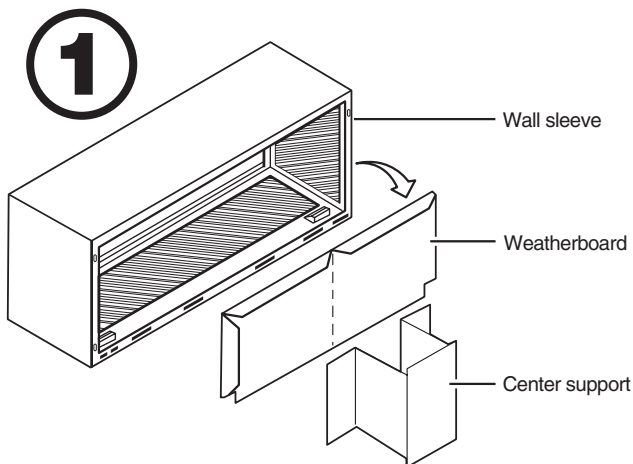

IMPORTANT: Use a wall sleeve adapter kit (PXSE) if installing a P-Series chassis in a T-Series sleeve.



WARNING

Suffocation hazard
Keep bag away from babies and children.
Do NOT use in cribs, beds or playpens. Destroy immediately after opening. This bag is NOT a toy.
Failure to do so can result in personal injury and/or death

2. Remove the front cover contained in a protective plastic bag from chassis. Remove the bag and dispose of it properly.
If the control door is not installed, follow these steps:
 - From the front of the cover, slide the right control door pin into the hole on the right side of the front cover. Slide the left door pin into the hole on the left side of the front cover opening and snap it into place.

NOTE: To avoid breaking the door or hinge pins, do not apply excessive force when installing

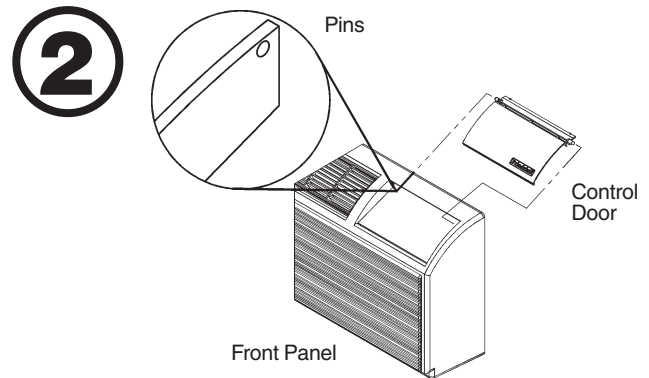

3. Remove the two chassis shipping brackets from the ends of the shipping pallet.

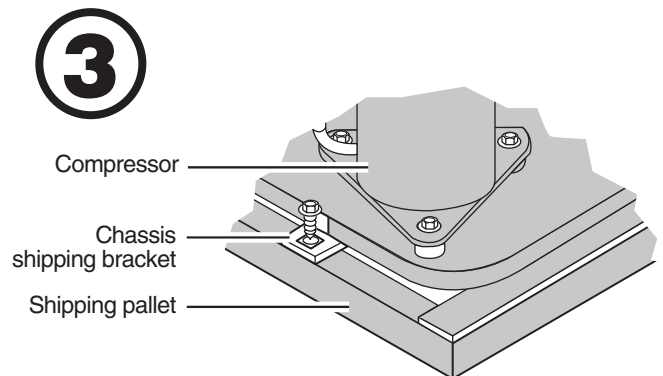

IMPORTANT: When installing a Friedrich P-Series PTAC into an existing sleeve, it is important to ensure that the unit is installed completely. Inspection of the air seal between the condenser air baffles and around the indoor mounting flange is recommended. In some cases additional gaskets or baffling may be required.

- Center the chassis in the pre-installed sleeve and carefully push the chassis until the chassis flange and gasket contact the sleeve flange.

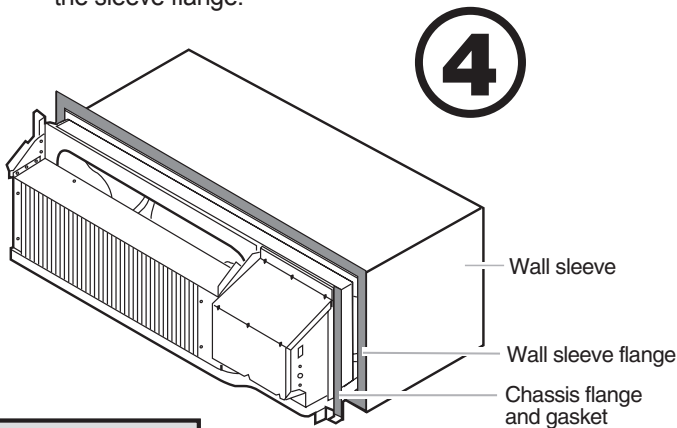

CAUTION

Cut/Sever
Although great care has been taken to minimize sharp edges in the construction of your unit, use gloves or other hand protection when handling unit. Failure to do so can result in minor to moderate personal injury.

NOTICE

Copper refrigerant tubes are **NOT** handles. Do **NOT** use tubing to lift or move chassis.

NOTE: If the unit is mounted flush to the floor, the service cord **MUST** be rerouted at the bottom of the front cover on the side closest to the receptacle. A notch **MUST** be made in the front cover side where the cord exits the unit. It is the responsibility of the installer to create an exit notch. See diagram 8 for suggested opening size and placement.

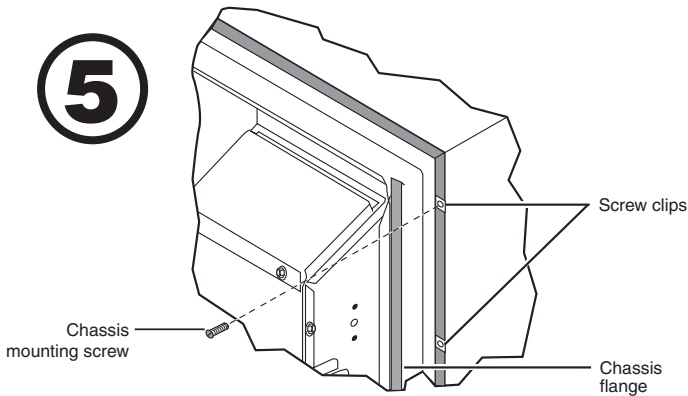

- Locate the four #10 x 1" chassis mounting screws. Tighten the screws into the clips - adjacent to the alignment dimples on the mounting brackets on the wall sleeve flange (two per side).
- Install the front cover assembly (including the discharge grille) by placing the top of the cover onto the 90° angle bracket along the top of the chassis. Rotate the bottom into place and insert the included thumb screws into the slots

located at the bottom back corners of the cover. Tighten them into the quick nuts located on the chassis to secure the cover.

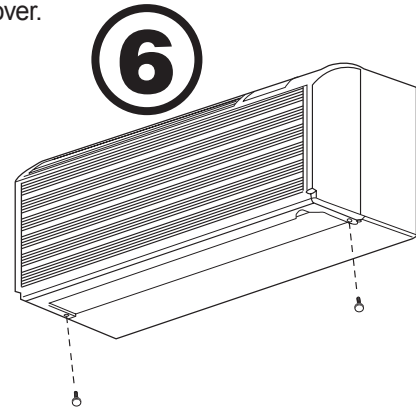

- If the filters are not already installed in tracks in the plastic cover, slide them into place.
- Plug the cord (if applicable) into the appropriate receptacle. Extra cord may be coiled inside the front cover behind the return air grille. Restore power to the unit.

CAUTION

Excessive Weight Hazard
Use two or more people when installing your air conditioner. Failure to do so can result in back or other injury.

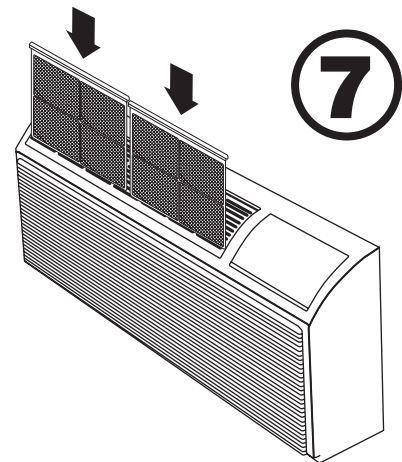

To remove the front cover, remove the thumbscrews at the bottom back corners of the cover (or sides). Pull the bottom end forward and lift it up to clear the L bracket across the top of the chassis.

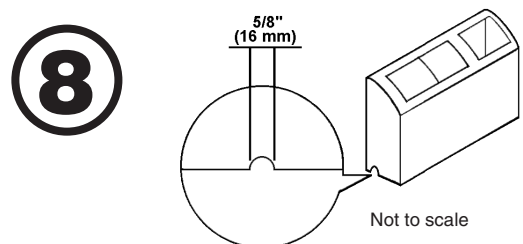

If a remote thermostat is to be installed, proceed to page 20, Step 1. For a 265 V unit, proceed to Appendix A, Step 1.

Digital Control User Input Configuration

The adjustable control dip switches are located at the lower left hand portion of the digital Smart Center. The inputs are only visible and accessible with the front cover removed from the PTAC.

Dip Switch Setting

1) Electronic Temperature Limiting – Switches 1-4

The digital control is set from the factory to allow a temperature range between 60°F and 90°F in both heating and cooling mode. Dip Switches 1-4 can be used to set high and low limits for either heating or cooling or both.

From the factory all four switches are in the up 'ON' position. The charts to the right show the available electronic limiting ranges.

2) Fan Cycle Control – Switch 5

All PTACs are shipped from the factory with Dip Switch 5 in the 'OFF' position to cycle the fan only when there is a demand for the compressor or heater. As an option the fan may be set to 'continuous' mode by switching Dip Switch 5 to 'ON' position to run the fan continuously while the unit is powered on.

To ensure that the room temperature is maintained evenly while in fan cycle mode the **Even Temp Load Anticipation** feature is enabled. **Quiet Fan Delay** is also enabled in fan cycle mode to lessen the acoustical change between compressor start up and shut off by running the fan for 5 seconds before each demand cycle, and 30 seconds after cooling or 15 seconds after heating cycles.

3) Room Freeze Protection – Switch 6

Units are shipped from the factory with the room freeze protection disabled. Room Freeze Protection can be switched on at the owner's preference by moving Dip Switch 6 to 'ON'. This feature will monitor the indoor room conditions and in the event that the room falls below 40°F the unit will cycle on high fan with the electric heater. This occurs regardless of mode.

4) Emergency Heat Override – Switch 7

In the unlikely event of a compressor failure a heat pump unit may be switched to operate in only the electric heat mode until repairs can be made. Moving Dip Switch 7 to 'ON'.

IMPORTANT PTAC must be disconnected from power supply when making any configuration changes.

Heating Range Switches 1 & 2

Temperature Range		Dip Switch	
Low	High	1	2
60	90	On	On
60	87	Off	On
60	84	Off	Off
60	81	On	Off

Cooling Range Switches 3 & 4

Temperature Range		Dip Switch	
Low	High	3	4
60	90	On	On
63	90	On	Off
66	90	Off	Off
69	90	Off	On

Digital Control Operation

Temperature Display

The Friedrich digital PTAC is shipped from the factory to display the desired room temperature on the LED readout.

The unit can be configured to display the room temperature by simultaneously pressing the 'Cool' and 'High Fan' buttons for three seconds the display will show an 'R' for one seconds to acknowledge the change. The unit will display the setpoint whenever the 'Temp' \wedge or \vee buttons are pressed and then switch back to room temperature.

To revert back to displaying the setpoint only press the 'Cool' and 'Low Fan' buttons for three seconds simultaneously, the unit will display an 'S' for one seconds to acknowledge the change.

°F vs. °C Display

The unit is factory configured to display all temperatures in degrees Fahrenheit (°F). To switch to degrees Celsius press the 'Fan Only' and 'Low Fan' buttons simultaneously for three seconds. The display will show a 'C' as acknowledgement of the change.

To revert back to °F press the 'Fan Only' and 'Low Fan' buttons simultaneously for three seconds. The display will show an 'F' as acknowledgement of the change.

Figure 11

Factory Dip Switch Configuration

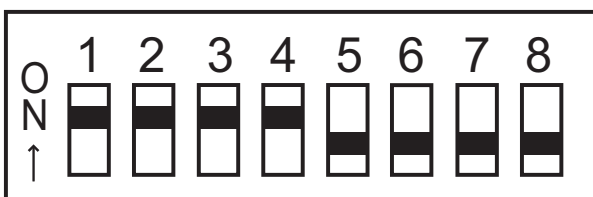

Cooling Mode

Pressing the 'Cool' button while the unit is in any mode, including off, will put the unit into cooling mode. Adjust the temperature readout to the desired room temperature and the unit will cycle the compressor on and off to maintain a comfortable room. The compressor will come on anytime that the room temperature is 1.8°F above the desired temperature. The fan operation is dependent on the fan mode selected, either continuous or cycling. See page 16 for fan cycle control.

Heating Mode

Pressing the 'Heat' button while the unit is in any mode, including off, will put the unit into heating mode.

Heat Pump Models (PDH)

When the 'Heat' button is pressed initially the unit will energize the electric resistance heat to quickly bring the room to the set temperature. When the desired room temperature falls 1.8°F below the desired set temperature the unit will cycle the compressor on and operate as a heat pump to maintain the room temperature while running more efficiently than resistance heat only models. If the room temperature should fall more than 5°F from the set temperature the unit will run the resistance heater. The fan operation is dependent on the fan mode selected, either continuous or cycling. Dip switch 5 controls the fan mode, see page 17 for setting.

When the outdoor coil temperature falls below 30°F for more than 2 minutes the unit will operate the resistance heaters and not the compressor. When the outdoor coil temperature reaches 45°F the compressor will be allowed to operate again.

Heat/Cool Models (PDE)

After pressing the 'Heat' button, adjust the temperature readout to the desired room temperature and the unit will cycle the resistance heat on and off to maintain a comfortable room. The heater will come on anytime that the room temperature is 1.8°F below the desired temperature. The fan operation is dependent on the fan mode selected, either continuous or cycling. Dip switch 5 controls the fan mode, see page 16 for setting.

Emergency Heat Operation

In the event of a compressor failure in heat pump mode the compressor may be locked out to provide heat through the resistance heater. This feature ensures that even in the unlikely event of a compressor failure the room temperature can be maintained until the compressor can be serviced. Dip switch 7 controls the emergency heat setting, see page 16.

Fan Mode

Fan Only

Pressing the 'Fan Only' button will run the fan to allow for air circulation in the room without operating the compressor or heater regardless of the room or set temperature. The fan speed selection is made by pressing either the 'High Fan' or 'Low Fan' button.

Figure 12
Digital Control Panel

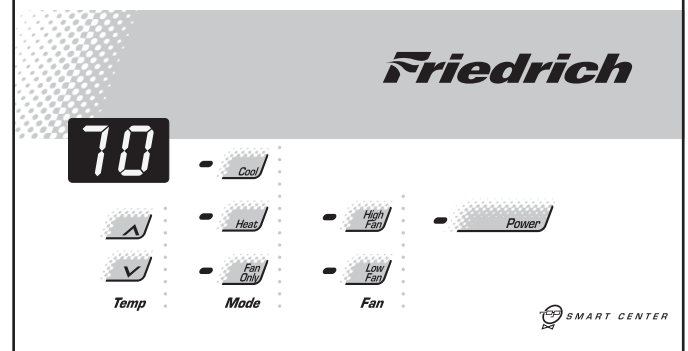
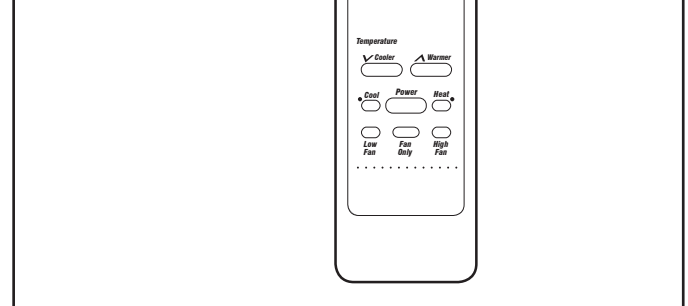

Figure 13
Remote Control



Cycle/Continuous

The owner may choose between fan cycling or fan continuous mode based on property preference (Note: Even heat monitoring and quiet start/stop fan delay only operate in fan cycle mode). Fan continuous mode is used to keep constant airflow circulation in the room during all times the unit is 'ON'. Fan cycle will conserve energy by only operating the fan while the compressor or electric heater is operating. Dip switch 5 controls the fan mode, see page 17 for setting.

Optional Hand Held Remote Control Operation

Friedrich PTAC units can be configured to operate via an optional hand held remote control for added convenience. The PTAC control board comes shipped with all of the necessary hardware to communicate to the PDXRC remote control. In order to operate the unit with the remote control, the remote control sensor must be enabled. Simply press and hold the 'Temp' ▲ and ▼ buttons simultaneously for three seconds, and the LED window will display and "E" for confirmation when the remote is enabled. To disable the feature press 'Temp' ▲ and ▼ buttons at the same time for three seconds. LED will display an "F" as acknowledgment for one second.

The remote control is now ready for use. The temperature, mode and fan speed control from the remote control will operate the unit the same as the unit mounted controls.

NOTE: The hand held remote control cannot be used in conjunction with a wall mounted thermostat.

Remote Control Operating Range

The hand held remote has an operating range of up to 25 feet. The infrared remote control signal must have a clear path to transmit the command to the PTAC unit. The remote signal has some ability to “bounce” off of walls and furniture similar to a television remote control. The diagram below shows the typical operating range of the control in a standard room with 8 ft high ceilings.

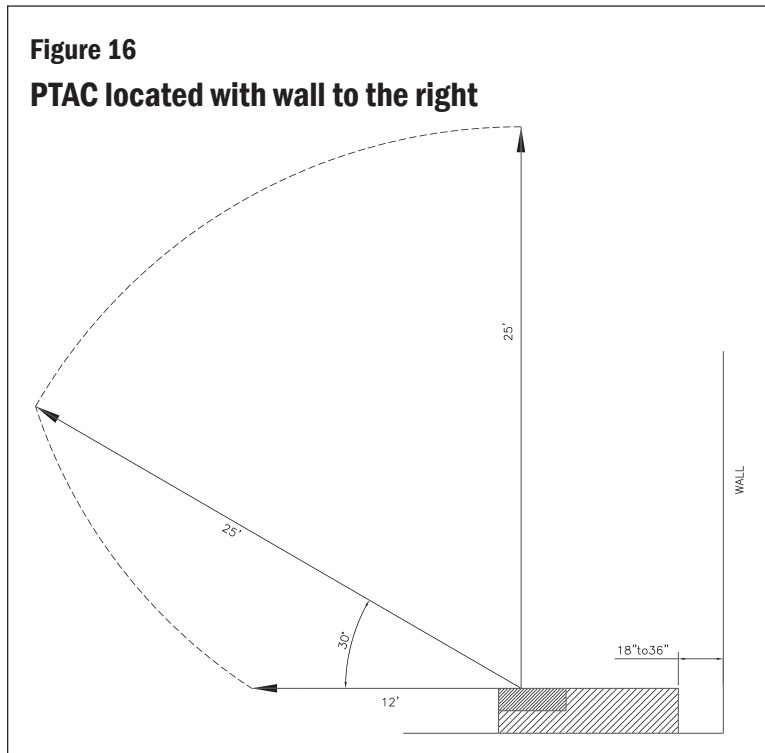
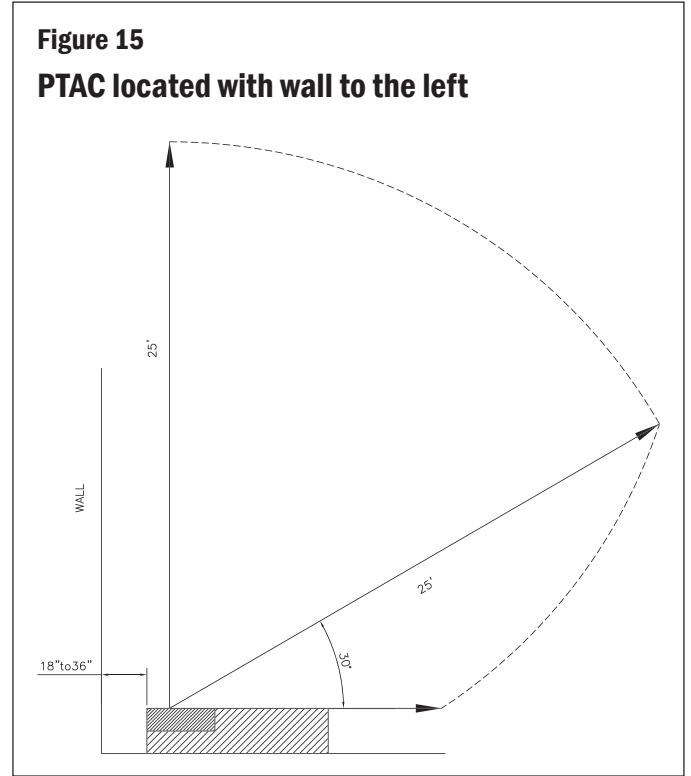
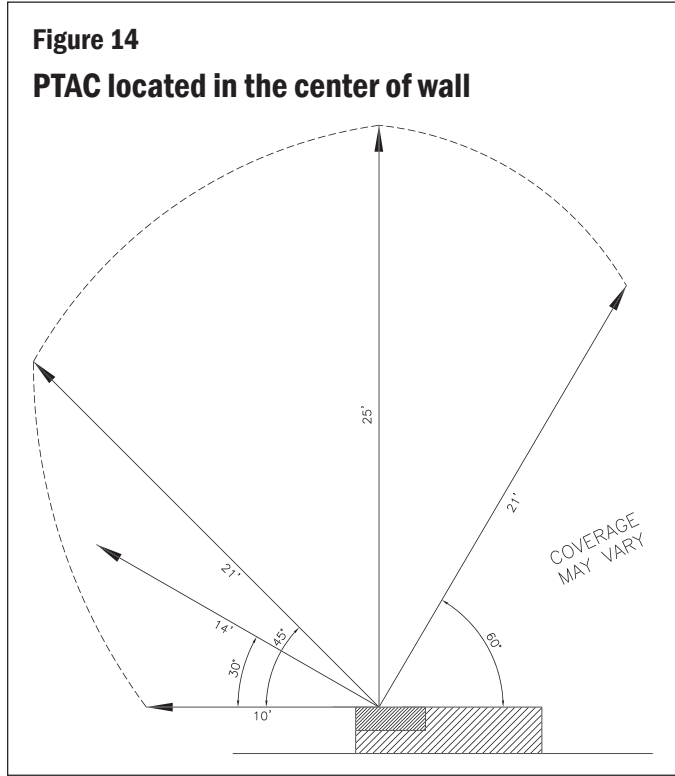

Remote Thermostat and Low Voltage Control Connections

Remote Thermostat

All Friedrich PD model PTAC units are factory configured to be controlled by either the chassis mounted Smart Center or a 24V single stage remote wall mounted thermostat. The thermostat may be auto or manual changeover as long as the control configuration matches that of the PTAC unit.

To control the unit with a wall mounted thermostat follow the steps below:

- 1) Unplug the unit before doing any work.
- 2) With the front cover removed locate the low voltage terminal strip at the lower portion of the Smart Center.
- 3) Remove the jumper between the 'GL' and GH' terminals.
- 4) The control is now configured for control by a wall thermostat. The Smart Center will no longer control the unit.
- 5) If desired the accessory escutcheon kit (PDXRT) is to be used, install it over the existing control panel.

Note: To revert back to the Smart Center control of the unit replace the jumper wire between the 'GL' and 'GH' terminals that was removed in step 1.

Thermostat Connections

- C = Common Ground
- W = Call for Heating
- Y = Call for Cooling
- R = 24V Power from Unit
- GL = Call for Low Fan
- GH = Call for High Fan
- B = Reversing Valve Energized in heating mode (PDH Models Only)

*If only one G terminal is present on thermostat connect to GL for low fan or to GH for high fan operation.

Figure 17

Control board with optional PDXRT escutcheon kit installed

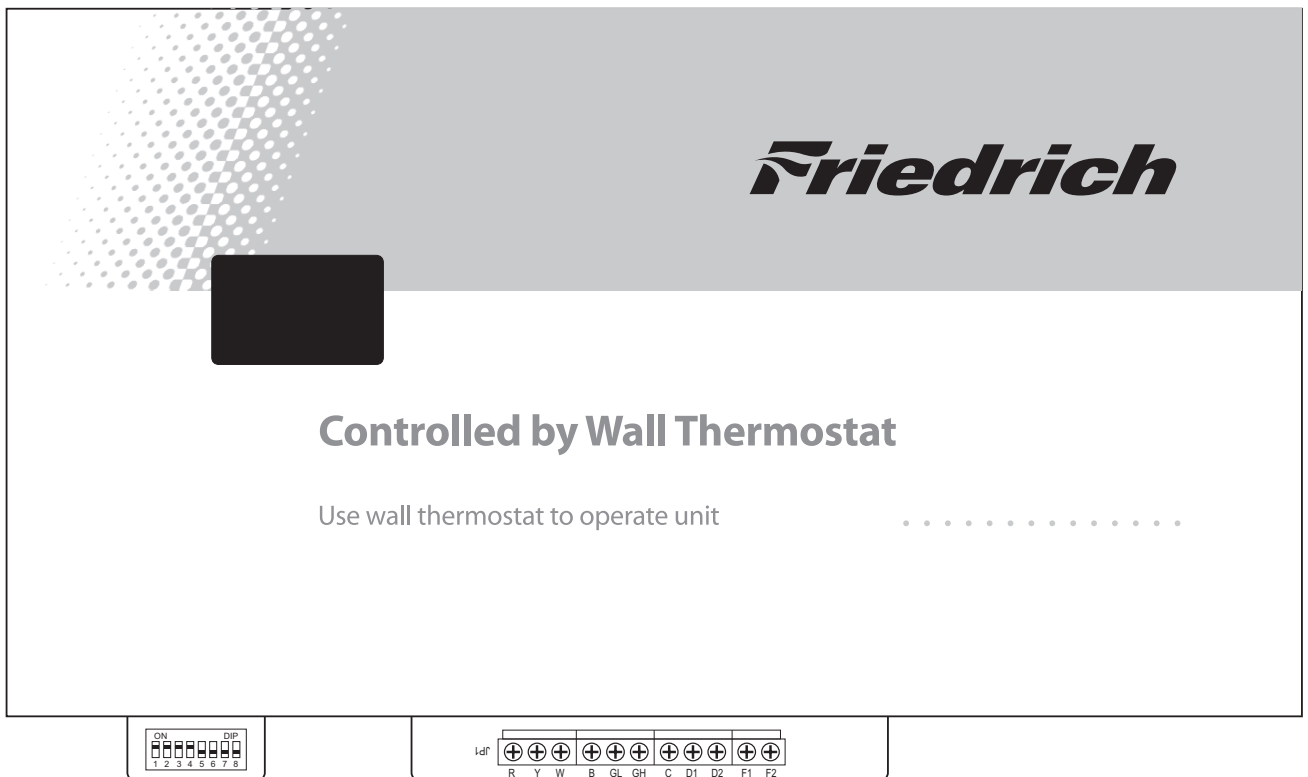

Desk Control Terminals

The Friedrich PD model PTAC has built-in provisions for connection to an external switch to control power to the unit. The switch can be a central desk control system or even a normally open door switch.

For desk control operation connect one side of the switch to the D1 terminal and the other to the D2 terminal (See figure 17). Whenever the switch closes the unit operation will stop.

Maximum Wire Length for Desk Control Switch

Wire Size	Maximum Length
#24	400 ft.
#22	600 ft.
#20	900 ft.
#18	1500 ft.
#16	2000 ft.

Note: The desk control system and switches must be field supplied.

Auxiliary Fan Control

The Smart Center also has the ability to control a 24VAC relay to activate an auxiliary, or transfer, fan. The outputs are listed as F1 and F2 on the control board.

To connect the relay, simply wire one side of the relay to F1 and the other side to F2. Anytime that the PTAC fan runs the terminals will send a 24VAC signal to the relay. The relay must be 24 VAC, 50mA or less.

Note: The relay and auxiliary fans must be field supplied.

NOTE: It is the installer's responsibility to ensure that all control wiring connections are made in accordance with the installation instructions. Improper connection of the thermostat control wiring and/or tampering with the unit's internal wiring can void the equipment warranty and may result in property damage, personal injury or death. Other manufacturer's PTACs and even older Friedrich models may have different control wire connections. Questions concerning proper connections to the unit should be directed to the factory.

Fresh Air Vent Control

The vent control lever is located behind the front cover on the left side of the unit. The unit is shipped in the closed position with a locking screw in place. The screw must be removed to operate the lever. When the lever is back, (OPEN), outside air is mixed with indoor air. When the lever is forward, (CLOSED), no outside air is admitted into the room and room air is recycled through the unit.

NOTE: The vent should remain closed for peak operating efficiency.

OPEN OUVERT ABIERTA	VENT AERATION SALIDA (ESCAPE) DEL AIRE	CLOSED FERMÉ CERRADA
---------------------------	---	----------------------------

FRESH AIR DOOR IS FACTORY SHIPPED IN CLOSED POSITION. REMOVE TOP SCREW ON LEVER TO OPEN DOOR.

250-453-01

Air Discharge Grille

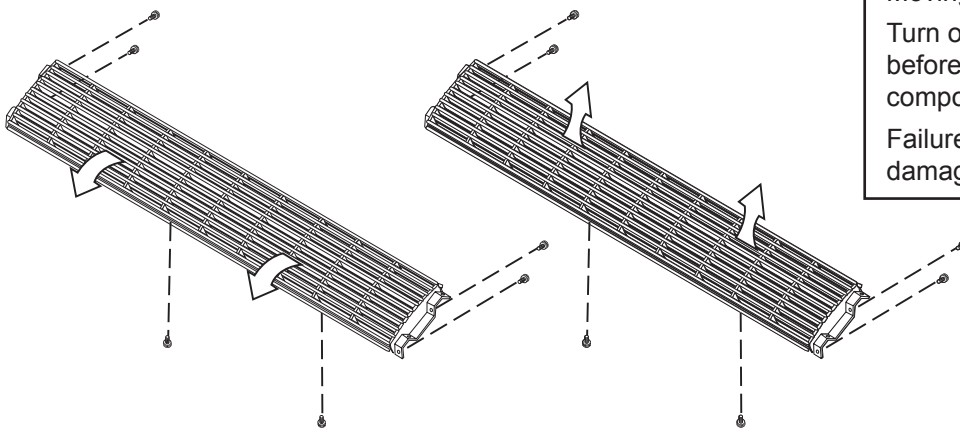

WARNING

Moving parts hazard. Turn off electric power before servicing this component. Failure to do so can result in property damage, personal injury and/or death.

The air discharge grille can be redirected to blow air either straight up or at an angle into the room. To change the airflow direction, remove the front cover, locate and remove the six grill retaining screws. Reverse the ends of the grille and reattach the grille to the cover.

Start-up Checklist

- Inspect all components and accessories for damage before and after installation.
 - Check installation for compliance with all national and local codes and ordinances.
 - Read and follow all manufacturer's installation instructions.
 - Check that circuit breaker(s) and electrical wire sizes are correct. If the unit is supplied with a power supply cord, insure that it is stored properly.
 - Check the condensate water drain outlet(s) to make sure they are in compliance with all national and local codes, that they are adequate for the removal of condensate water, and that they meet the approval of the end user.
 - Strictly follow installation instructions concerning clearances around the unit.
 - Secure components and accessories, such as the control door and front cover.
 - Check the unit air filter, condenser coil and evaporator coil for any obstructions.
 - Check for proper operation of all components.
 - Instruct the owner or operator of the units operation, and the manufacturer's recommended routine maintenance schedule.
- NOTE: It is highly recommended that a maintenance schedule log book be prepared for recording the dates and times of service.**
- Operate the unit for twenty minutes. Record the unit's indoor/outdoor intake and discharge temperatures, amperage draw, and power voltage.
 - Assemble the Warranty Certificate, the Operation and Installation Manual, all accessory installation instructions and the name, address and telephone number of the Authorized Friedrich Warranty Service Company in the area for the owner or operator.

NOTE: Units are to be installed, inspected, and checked by qualified service personnel only.

Appendix A: Electrical Wiring for 265 Volt Models

NOTE: It is recommended that the PXSB subbase assembly, the PXCJ conduit kit (or equivalent) be installed on all hardwired units. If installing a flush-floor mounted unit, make provisions for all the line voltage power leads and conduit to be removed for ease of maintenance and service to the chassis.

To install the line voltage power leads and conduit to the chassis, follow the instructions below.

1. Remove the four control box retaining screws (A) and open the control box.
2. Pull the chassis power lead wires (B) (located on the bottom-right side of the control box) through the plastic bushing so they are located inside the control box.
3. Remove the plastic bushing.
4. Route the line voltage power leads through the hole where the plastic bushing was located, and secure its conduit (use a 1/2" straight conduit connector, with the locknut on the inside of the control box.)
5. Make the appropriate electrical connections within the control box, then secure the box on the chassis. Detailed instructions are included with the installation instructions for the conduit kit (PXCJ).
6. Route the line voltage power conduit from the control box straight down the right front to the bottom side of the chassis. This will allow the front cover to be installed without interference with the electrical conduit.

Figure 18

Line Voltage Connections

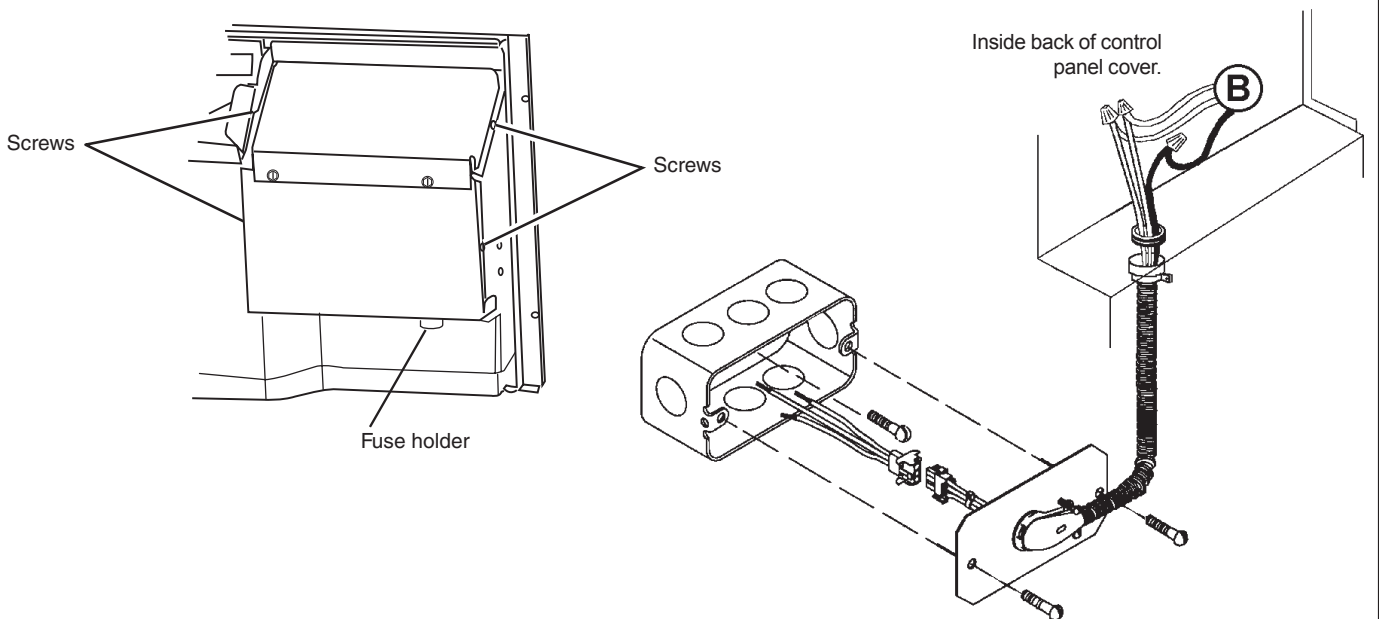

WARNING



ELECTRIC SHOCK HAZARD! Turn off electric power before service or installation. All electrical connections and wiring **MUST** be installed by a qualified electrician and conform to the National Electrical Code and all local codes which have jurisdiction. Failure to do so can result in property damage, personal injury and/or death.

Routine Maintenance

NOTE: Units are to be inspected and serviced by qualified service personnel only.

1. Clean the unit air intake filter at least every 300 to 350 hours of operation. Clean the filters with a mild detergent in warm water and allow to dry thoroughly before reinstalling.
2. The indoor coil (evaporator coil), the outdoor coil (condenser coil) and base pan should be inspected periodically (yearly or bi-yearly) and cleaned of all debris (lint, dirt, leaves, paper, etc.). Clean the coils and base pan with a soft brush and compressed air or vacuum. If using a pressure washer, be careful not to bend the aluminium fin pack. Use a sweeping up and down motion in the direction of the vertical aluminum fin pack when pressure cleaning coils. Cover all electrical components to protect them from water or spray.
3. Periodically (at least yearly or bi-yearly): inspect all control components, both electrical and mechanical, as well as the power supply. Use proper testing instruments (voltmeter, ohmmeter, ammeter, wattmeter, etc.) to perform electrical tests. Use an air conditioning or refrigeration thermometer to check room, outdoor and coil operating temperatures. Use a sling psychrometer to measure wet bulb temperatures indoors and outdoors.
4. Inspect the surrounding area (inside and outside) to ensure that the units' clearances have not been compromised or altered.
5. Inspect the sleeve and drain system periodically (at least yearly or bi-yearly) and clean of all obstructions and debris. Clean both areas with an antibacterial and antifungal cleaner. Rinse both items thoroughly with water and ensure that the drain outlets are operating correctly. Check the sealant around the sleeve and reseal areas as needed.
6. Clean the front cover when needed. Use a mild detergent. Wash and rinse with warm water. Allow them to dry thoroughly before reinstalling them in the chassis.

Before reinstalling the chassis in the sleeve, inspect the indoor blower housing, blower wheel, condenser fan blade, and condenser shroud periodically (yearly or bi-yearly) and clean of all debris (lint, dirt, mold, fungus, etc.) Clean the blower housing area and blower wheel with an antibacterial / antifungal cleaner. Use a biodegradable cleaning agent and degreaser on condenser fan and condenser shroud. Use warm or cold water when rinsing these items. Allow the unit to dry thoroughly, inspect all gasket material for deterioration (replace as necessary), and then reinstall the chassis in the sleeve.

NOTICE Do not use a caustic coil cleaning agent on coils or base pan. Use a biodegradable cleaning agent and degreaser.

Figure 19
Components

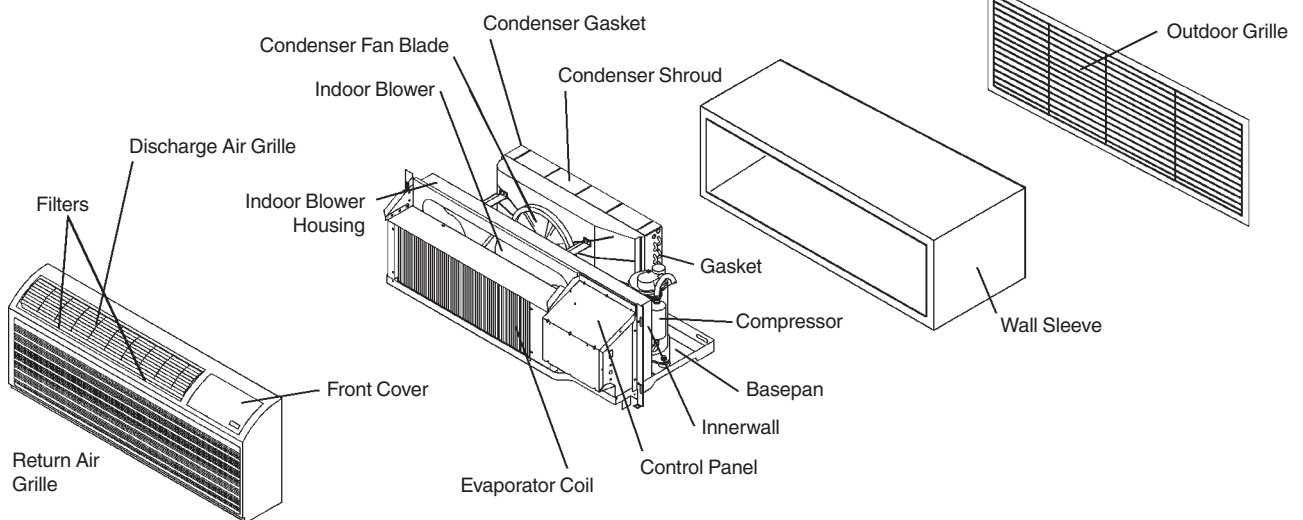

Basic Troubleshooting Techniques

Being familiar with the sequence of operation on Standard Controlled Operating Units or the operation of the Remote Thermostat Controlled Units is important. The following questions and answers may help to identify performance problems.

Environmental Effects - Cooling Mode

Is unit sized to room size area and heat load demand?

The number of people in the room, number of electrical devices, solar gains, etc. are all variable items that can affect proper sizing of the unit. Friedrich recommends that you consult with an applications engineer for proper sizing.

Is the outdoor temperature 60°F or below?

The unit is designed for outdoor temperatures above 60°F.

Is the indoor temperature 80°F or above?

Ambient indoor temperatures of 80°F or above will take a longer period of run time to cool down the area. Long run times may indicate that the unit is undersized.

Is indoor humidity high?

This condition will cause the unit to operate longer to remove humidity before noticing any cooling effect.

Has the heat load been increased by additional devices such as computer equipment, or has the room area been increased where the unit is located?

If conditions have changed, the unit may not be able to cool and condition as effectively as previously planned.

Environmental Effects - Heating Mode

Is unit properly sized to room area and heat load demand?

The number of people in the room, number of electrical devices, solar gains, etc. are all variable items that can affect proper sizing of the unit. Friedrich recommends that you consult with an applications engineer for proper sizing.

Is the outdoor temperature 70°F or above?

The unit is designed for outdoor temperatures below 70°F. Is the indoor temperature 60°F or below? Ambient indoor temperatures of 60°F or below will take a longer period of run time to heat the area. Long run times may indicate that the unit is undersized.

Has the room area been increased where the unit is located?

If the area where the unit is located has been increased, the unit may not provide adequate heat.

Insufficient Maintenance and Inspection

Installation errors are the most common cause of poor performance. Please follow installation instructions carefully. If other problems exist, see Maintenance and Inspection Troubleshooting Guide below.

Maintenance and Inspection Troubleshooting Guide

CAUSE	RESULT
System is not serviced or inspected regularly (semiannually or annually).	Can result in premature component failures, poor performance and increased operating costs.
Air filters are not cleaned regularly and become blocked with particles.	May result in poor cooling, icing and water problems as well as component failures and increased operating costs.
Condenser coil not maintained properly (blocked with particles).	May result in poor cooling, component failures and increased costs.
Evaporator coil not maintained properly (blocked with particles).	May result in poor cooling, icing and water problems, and increased operating costs.
Components that show signs of fatigue - not replaced.	May result in multiple service calls, poor performance and increased operating costs.
Condensate drains and drain lines not maintained.	May result in water and odor problems.

Digital Control Diagnostics and Test Mode

Diagnostics

The Friedrich Smart Center continuously monitors the PTAC unit operation and will store service codes if certain conditions are witnessed. In some cases the unit may take action and shut the unit off until conditions are corrected.

To access the error code menu press the **'Heat'** and **'High Fan'** buttons simultaneously for three seconds. If error codes are present they will be displayed. If multiple codes exist you can toggle between messages using the temp **▲** button. To clear all codes press the temp **▼** button for three seconds while in the error code mode. To exit without changing codes press the **'Low Fan'** button.

The chart below lists the possible error codes and their description:

Test Mode

For service and diagnostic use only, the built-in timers and delays on the PTAC may be bypassed by pressing the **'Cool'** and **'Low Fan'** buttons simultaneously for three seconds while in any mode to enter the test mode. **CE** will be displayed when entering test mode, and **DE** will be displayed when exiting. The test mode will automatically be exited 30 minutes after entering it or by pressing the **'Cool'** and **'Low Fan'** buttons simultaneously for three seconds.

Error Code	Code Translation	Action Taken by Unit	Possible Cause
EF	"Error Free" - No Codes Stored	None	Unit Operating Normally
02	An extreme low voltage condition exists <198V for 230V units and <239V for 265V units.	Shut down unit. Display Error code and flash. Once voltage rises to normal level system power is restored.	<ul style="list-style-type: none"> Inadequate power supply Defective breaker Blown fuse
03	Return air thermistor sensor open or short circuit	Set return air sensor = 75°F. Alternately flash set point and error code. Leave unit running.	<ul style="list-style-type: none"> Defective sensor
04	Indoor coil thermistor sensor open or short circuit	Set ID coil temp = 40°F. Alternately flash set point and error code. Leave unit running.	<ul style="list-style-type: none"> Defective sensor
05	Outdoor coil thermistor sensor open Or short circuit	Set OD coil temp = 20°F. Alternately flash set point and error code. Automatically change over to Electric heat Mode only. Leave unit running.	<ul style="list-style-type: none"> Defective sensor
06	If O.D. coil Temperature > 175 Deg F for 2 consecutive minutes. (Heat Pump models only)	Alternately flash set point and error code. Shut unit down for 5 minutes, then try again 2 times, if fails the 3rd time then shut down unit.	<ul style="list-style-type: none"> Dirty coil Fan motor failure Restricted air flow Non-condensables in refrigeration system
07	I.D coil temperature <30 Deg F for 2 consecutive minutes.	Alternately flash set point and error code. Continue fan operation while the compressor is locked out until the indoor coil thermistor reaches 45° F, then energize the compressor. However, compressor must still wait a lockout time of 180 to 240 seconds.	<ul style="list-style-type: none"> Dirty filters Dirty coil Fan motor failure Restricted airflow Improper refrigerant charge Restriction in refrigerant circuit
08	Unit cycles (Heat or Cool demand) > 9 times per hour	Store error code in memory. Keep unit running	<ul style="list-style-type: none"> Unit oversized Low load conditions
09	Unit cycles (Heat or Cool demand) < 3 times per hour	Store Error Code in memory. Keep unit running	<ul style="list-style-type: none"> Unit undersized High load conditions
10	Room Freeze Protection triggered	Alternately flash set point and error code. Keep unit running.	<ul style="list-style-type: none"> Room temperature fell below 40°F
11	No Signal to "GL or "GH" terminal (Remote Thermostat mode only)	Shut down unit. Display error code and flash.	<ul style="list-style-type: none"> Defective remote thermostat Defective thermostat wiring
12	Discharge air temperature >185° F	Alternately flash set point and error code. Open all relays and run high fan. If condition repeats three times in one hour, shut down unit.	<ul style="list-style-type: none"> Restricted air flow Fan motor failure
13	If Pressure limit switch opens	Turn OFF compressor. Alternate flash set point and error code	
14	Discharge air temperature sensor open or shorted	Set the temperature sensor = 75° F Alternately flash set point and error code. Leave unit running.	<ul style="list-style-type: none"> Defective Sensor

Friedrich PTAC Accessories

NEW CONSTRUCTION ACCESSORIES

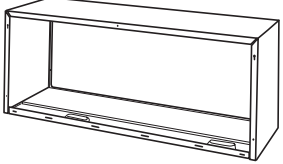
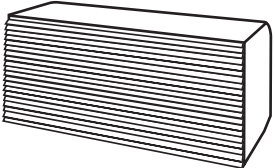
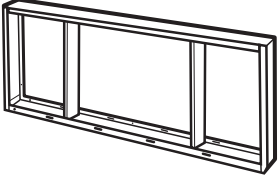
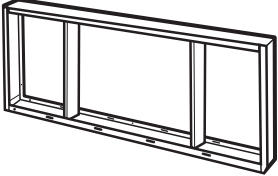
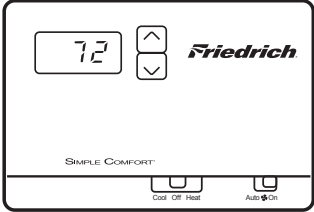
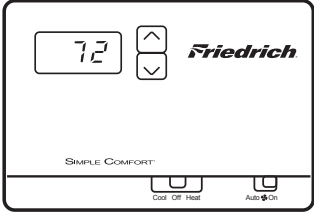
MODEL NUMBER	DESCRIPTION	PHOTO
PDXWS	WALL SLEEVE Galvanized zinc coated steel is prepared in an 11-step process, then powder coated with a polyester finish and cured in an oven for exceptional durability. The wall sleeve is insulated for sound absorption and thermal efficiency. 16" High x 42" Wide x 13 3/4" Deep.	
PXGA	GRILLE Standard, stamped aluminium, anodized to resist chalking and oxidation.	 PXAA
PXAA PXBG PXSC	ARCHITECTURAL GRILLES Consist of heavy-gauge 6063-T5 aluminum alloy: PXAA– Clear, extruded aluminum PXBG– Beige acrylic enamel PXSC– Also available in custom colors.	
PXDR10	CONDENSATE DRAIN KIT Attaches to the bottom of the wall sleeve for internal draining of condensate or to the rear wall sleeve flange for external draining. Recommended on all units to remove excess condensate. Packaged in quantities of ten.	
PXWE	DEEP WALL SLEEVE EXTENSION A four-inch deep anodized aluminium extension that attaches to the outside of the wall sleeve when the wall is greater than 11 inches thick (9 1/2" when a subbase is used, 10 inches when a lateral duct is used). Up to three extensions may be used together.	
PXSB	DECORATIVE SUBBASE Provides unit support for walls less than six inches thick. Includes leveling legs, side filler panels and mounting brackets for electrical accessories. Accepts circuit breaker, power disconnect switch, or conduit kit.	
RT4	DIGITAL REMOTE WALL THERMOSTAT Single stage thermostat used on PTAC units. Hard wired with single speed fan. Direct replacement for RT2.	 RT4
RT5	DIGITAL REMOTE WALL THERMOSTAT Single stage thermostat features high/low fan speed switch. Thermostat is hard wired and can be battery powered or unit powered. Features backlit display and multiple configuration modes. For use on PD-series Friedrich PTACs only.	
PDXRT	REMOTE THERMOSTAT ESCUTCHEON KIT This kit contains ten escutcheons that can be placed over the factory control buttons when a remote wall mounted thermostat is used. The escutcheon directs the guest to the wall thermostat for operation and retains the LED window to display error codes and diagnostic information.	

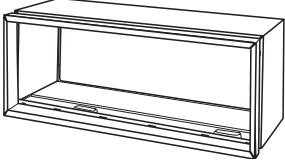
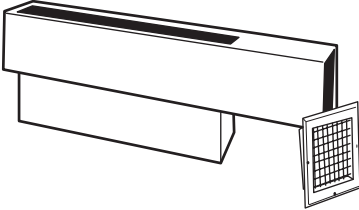
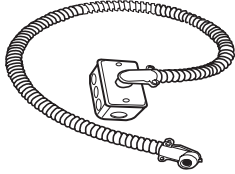
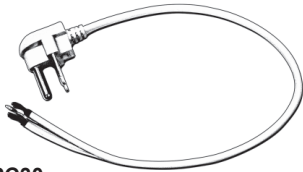
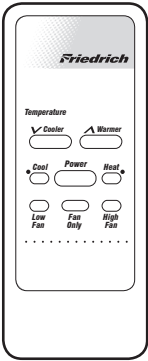
ADDITIONAL ACCESSORIES		
MODEL NUMBER	DESCRIPTION	PHOTO
PXSE	SLEEVE EXTENSION RETROFIT KIT Galvanized zinc coated steel, 2.4" sleeve extension attached to the room side of the sleeve to allow for the installation of a PD-Series Friedrich PTAC in a T-Series sleeve.	
PDXDA	LATERAL DUCT ADAPTER Attaches to the PTAC/PTHP unit and provides a transition to direct up to 35% of the total CFM to a secondary room, either left or right of the unit. Kit includes duct plenum with discharge grille and internal baffle, adapter and end cap.	
PDXDE	LATERAL DUCT EXTENSION A three-foot insulated plenum that attaches to the left or right side of the duct adapter. The extension can be cut to length by the installer. Maximum allowable straight extension is 15 feet.	
PXCJ	CONDUIT KIT WITH JUNCTION BOX Hard wire conduit kit with junction box for 208/230V and 265V units (subbase not required). Kit includes a means of quick disconnect for easy removal of the chassis. *Required for 265V installations.	
PXPC 15/20/30	POWER CORD RETROFIT Replaces LCDI power cord on 230V models when unit is used with a subbase. PXPC15 is used with 15 amp 2.5 kW units. PXPC20 is used with 20 amp 3.4 kW units. PXPC30 is used with 30 amp 5.0 kW units.	 PXPC30
PDXRC	REMOTE CONTROL KIT Comes with one hand-held remote for control of the PTAC unit.	
CHASSIS OPTIONS		
DESIGNATOR	DESCRIPTION	
S	STANDARD UNIT Standard PTAC/PTHP chassis. Can be 230/208V or 265V, electric or heat pump.	



Friedrich Air Conditioning Company

P.O. Box 1540
San Antonio, TX 78295
210.357.4400
www.friedrich.com

PD-SERIES PACKAGED TERMINAL AIR CONDITIONERS LIMITED WARRANTY

SAVE THIS CERTIFICATE. It gives you specific rights, you may also have other rights which may vary from state to state and province to province.

In the event that your unit needs servicing, contact your nearest authorized service center. If you do not know the nearest service center, ask the company that installed your unit or contact us - see address and telephone number above. **When requesting service:** please have the model and serial number from your unit readily available.

Unless specified otherwise herein, the following applies: **PACKAGED TERMINAL AIR CONDITIONERS AND HEAT PUMPS**

LIMITED WARRANTY - FIRST YEAR (Eighteen (18) Months from the original date of purchase or twelve (12) months from installation). Any defect in the unit's material or workmanship will be repaired or replaced free of charge by our authorized service center during the normal working hours; and

LIMITED WARRANTY - SECOND THROUGH FIFTH YEAR (Sixty-six (66) months from the date of purchase) ON THE SEALED REFRIGERATION SYSTEM. Any part of the sealed refrigeration system on the P-series that is defective in material or workmanship will be repaired or replaced free of charge (excluding freight charges) by our authorized service center during normal working hours. The sealed refrigeration system consists of the compressor, metering device, evaporator, condenser, reversing valve, check valve, and the interconnecting tubing.

These warranties apply only while the unit remains at the original site and only to units installed inside the continental United States, Alaska, Hawaii, Puerto Rico and Canada. The warranty applies only if the unit is installed and operated in accordance with the printed instructions and in compliance with applicable local installation and building codes and good trade practices. For international warranty information, contact the Friedrich Air Conditioning Company - International Division.

Reasonable proof must be presented to establish the original purchase date, otherwise the beginning date of this certificate will be considered to be our shipment date plus sixty days. Replacement parts can be new or remanufactured. Replacement parts and labor are only warranted for any unused portion of the unit's warranty.

We will not be responsible for and the user will pay for:

1. Service calls to:
 - A) Instruct on unit operation.
 - B) Replace house fuses or correct house wiring.
 - C) Clean or replace air filters.
 - D) Remove the unit from inaccessible locations.
 - E) Correct improper installations.
2. Parts or labor provided by anyone other than an authorized service center.
3. Damage caused by:
 - A) Accident, abuse, negligence, misuse, riot, fire, flood, or acts of God.
 - B) Operating the unit where there is a corrosive atmosphere containing chlorine, fluorine, or any damaging chemicals (other than in a normal residential environment).
 - C) Unauthorized alteration or repair of the unit, which in turn affects its stability or performance.
 - D) Failing to provide proper maintenance and service.
 - E) Using other than a "Seacoast Protected" unit in a coastal environment.
 - F) Using an incorrect power source.
 - G) Faulty installation or application of the unit.

We shall not be liable for any incidental, consequential, or special damages or expenses in connection with any use or failure of this unit. We have not made and do not make any representation or warranty of fitness for a particular use or purpose and there is no implied condition of fitness for a particular use or purpose. We make no expressed warranties except as stated in this certificate. No one is authorized to change this certificate or to create for us any other obligation or liability in connection with this unit. Any implied warranties shall last for one year after the original purchase date. Some states and provinces do not allow limitations on how long an implied warranty or condition lasts, so the above limitations or exclusions may not apply to you. The provisions of this warranty are in addition to and not a modification of or subtraction from the statutory warranties and other rights and remedies provided by law.

In case of any questions regarding the provisions of this warranty, the English version will govern.

(12-04)