

This Owner's Manual is provided and hosted by [Appliance Factory Parts](#).



FRIEDRICH VEA24K50RTL-B Owner's Manual

[Shop genuine replacement parts for FRIEDRICH
VEA24K50RTL-B](#)



[Find Your FRIEDRICH Other Parts - Select From 56 Models](#)

----- Manual continues below part list -----

Available Replacement Parts for FRIEDRICH VEA24K50RTL-B

P60542007	FAN BLADE 16" TYPE=RAC
P03760548	TUBE CAP 054 ID X 37 1/4-40 WHITE TYPE=H
P80007600	NONFUSED DISCONNECT TYPE=INS
P60179904	CONDENSATE DRAIN VALVE TYPE=RAC
P61776905	MOTOR MOUNT TYPE=VPK
P80102292	HEATER VPAK-A24 NXT 5.0KW 230V TYPE=VPK
P80103200	BLOWER HOUSING TYPE=VPK
P80077118	REPLMT COMPR KIT PA200M2CS-3MUU GMC TYPE
P62600601	DISPLAY SERVICE VPAC KUHL TYPE=RAC
P91400402	Compressor Bolt



F R I E D R I C H

Single Package Vertical Air Conditioning System

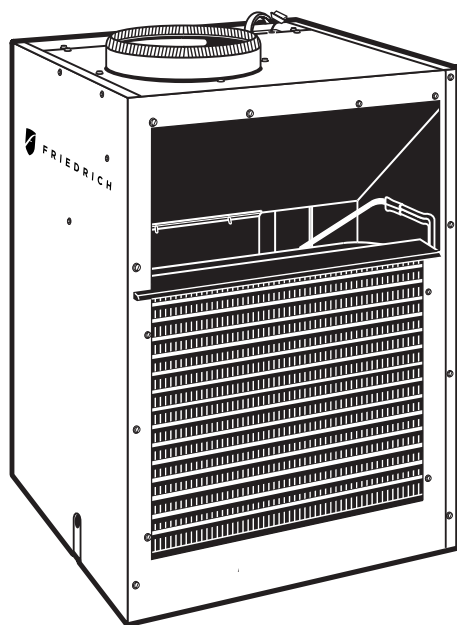

9-18K

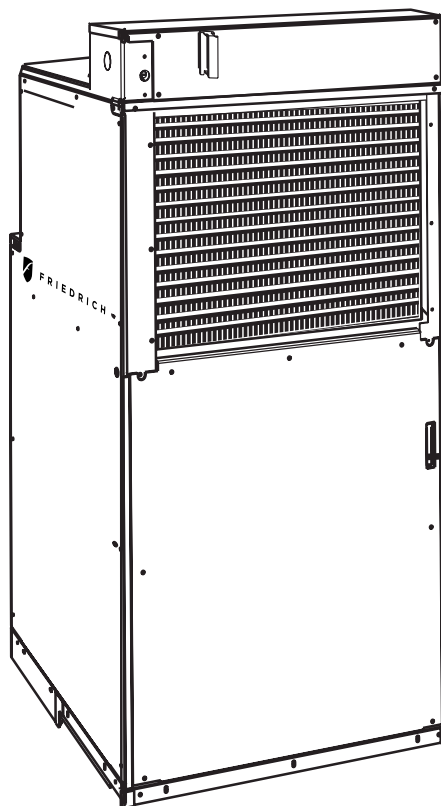

24K

VERT-I-PAK[®] A Series (Electronic Controls)

L-B Suffix, R410A Models

V(E, H)A09K25L-*	V(E, H)A09K34L-*	V(E, H)A09K50L-*
V(E, H)A12K25L-*	V(E, H)A12K34L-*	V(E, H)A12K50L-*
V(E, H)A18K25L-*	V(E, H)A18K34L-*	V(E, H)A18K50L-*
V(E, H)A24K25L-*	V(E, H)A24K34L-*	V(E, H)A24K50L-*
V(E, H)A24K75L-*	V(E, H)A24K10L-*	

Table of Contents

Important Safety Information	2-4	Reversing Valve Description/Operation	28
Introduction	4	Testing Coil	28
Vert-I-Pak Model Number Identification Guide	5	Checking Reversing Valves	28
Serial Number Identification Guide	5	Reversing Valve	
Electrical Requirements	6	Touch Testing Heating/Cooling Cycle	29
Chassis Specifications	7	Procedure For Changing Reversing Valve	29-30
Cooling Performance Data	8	Compressor Checks	30
Extended Cooling Performance	8	Locked Rotor Voltage Test	30
Electronic Control Features	9	Single Phase Connections	30
Electronic Control Sequence of Operation	10-11	Determine Locked Rotor Voltage	30
Low Voltage Interface Connections	12	Locked Rotor Amperage Test	30
Service	13	Single Phase Running & Locked Rotor Amperage	30
VPAK 9-18 BTU Units Components Identification	14	Checking the Overload	30
VPAK 9-18 BTU Units Components Identification	15	External Overload	31
Error Codes and Alarm Status	16	Compressor Single Phase Resistance Test	31
Components Testing	17	Compressor Replacement	32-33
Electronic Control Board Components Identification	18	Routine Maintenance	33
Components Testing (Continued)	19-22	Unit Performance Test Data Sheet	34
Refrigerant Sequence of Operation	23	Thermistor Resistance Values	35
Sealed Refrigeration System Repairs	24	Troubleshooting Charts	36-39
Refrigerant Charging	24	Remote Wall Thermostat Wiring Diagrams	40
Method Of Charging	22-23	Electrical and Thermostat Wiring Diagrams	41-46
Undercharged Refrigerant Systems	25	Accessories	47
Overcharged Refrigerant Systems	26	Warranty	48
Restricted Refrigerant Systems	26	VPAK 9-18K Parts	50-53
Capillary Tube Systems/Check Valve	27	VPAK 24K Parts	54-58
		Technical Support/Contact Info	59

IMPORTANT SAFETY INFORMATION

The information contained in this manual is intended for use by a qualified service technician who is familiar with the safety procedures required for installation and repair, and who is equipped with the proper tools and test instruments required to service this product.

Installation or repairs made by unqualified persons can result in subjecting the unqualified person making such repairs as well as the persons being served by the equipment to hazards resulting in injury or electrical shock which can be serious or even fatal.

Safety warnings have been placed throughout this manual to alert you to potential hazards that may be encountered. If you install or perform service on equipment, it is your responsibility to read and obey these warnings to guard against any bodily injury or property damage which may result to you or others.

Your safety and the safety of others are very important.

We have provided many important safety messages in this manual and on your appliance. Always read, understand and obey all safety messages.



This is a safety Alert symbol.

This symbol alerts you to potential hazards that can kill or hurt you and others.

All safety messages will follow the safety alert symbol with the word "WARNING" or "CAUTION". These words mean:



You can be killed or seriously injured if you do not follow instructions.



You can receive minor or moderate injury if you do not follow instructions.

All safety messages will tell you what the potential hazard is, tell you how to reduce the chance of injury, and tell you what will happen if the instructions are not followed.



A message to alert you of potential property damage will have the word "NOTICE". Potential property damage can occur if instructions are not followed.

PERSONAL INJURY OR DEATH HAZARDS

ELECTRICAL HAZARDS:

- Unplug and/or disconnect all electrical power to the unit before performing inspections, maintenance, or service.
- Make sure to follow proper lockout/tag out procedures.
- Always work in the company of a qualified assistant if possible.
- Capacitors, even when disconnected from the electrical power source, retain an electrical charge potential capable of causing electric shock or electrocution.
- Handle, discharge, and test capacitors according to safe, established, standards, and approved procedures.
- Extreme care, proper judgment, and safety procedures must be exercised if it becomes necessary to test or troubleshoot equipment with the power on to the unit.

- Do not spray or pour water on the return air grille, discharge air grille, evaporator coil, control panel, and sleeve on the room side of the air conditioning unit while cleaning.
- Electrical component malfunction caused by water could result in electric shock or other electrically unsafe conditions when the power is restored and the unit is turned on, even after the exterior is dry.
- Never operate the A/C unit with wet hands.
- Use air conditioner on a single dedicated circuit within the specified amperage rating.
- Use on a properly grounded electrical circuit only.
- Do not use extension cords with the unit.
- Follow all safety precautions and use proper and adequate protective safety aids such as: gloves, goggles, clothing, adequately insulated tools, and testing equipment etc.
- Failure to follow proper safety procedures and/or these warnings can result in serious injury or death.

REFRIGERATION SYSTEM HAZARDS:

- Use approved standard refrigerant recovering procedures and equipment to relieve pressure before opening system for repair.
- Do not allow liquid refrigerant to contact skin. Direct contact with liquid refrigerant can result in minor to moderate injury.
- Be extremely careful when using an oxy-acetylene torch. Direct contact with the torch's flame or hot surfaces can cause serious burns.
- Make sure to protect personal and surrounding property with fire proof materials.
- Have a fire extinguisher at hand while using a torch.
- Provide adequate ventilation to vent off toxic fumes, and work with a qualified assistant whenever possible.
- Always use a pressure regulator when using dry nitrogen to test the sealed refrigeration system for leaks, flushing etc.
- Make sure to follow all safety precautions and to use proper protective safety aids such as: gloves, safety glasses, clothing etc.
- Failure to follow proper safety procedures and/or these warnings can result in serious injury or death.

MECHANICAL HAZARDS:

- Extreme care, proper judgment and all safety procedures must be followed when testing, troubleshooting, handling, or working around unit with moving and/or rotating parts.
- Be careful when, handling and working around exposed edges and corners of sleeve, chassis, and other unit components especially the sharp fins of the indoor and outdoor coils.
- Use proper and adequate protective aids such as: gloves, clothing, safety glasses etc.
- Failure to follow proper safety procedures and/or these warnings can result in serious injury or death.

PROPERTY DAMAGE HAZARDS

FIRE DAMAGE HAZARDS:

- Read the Installation/Operation Manual for this air conditioning unit prior to operating.
- Use air conditioner on a single dedicated circuit within the specified amperage rating.
- Connect to a properly grounded electrical circuit only.
- Do not use extension cords with the unit.
- Failure to follow these instructions can result in fire and minor to serious property damage.

WATER DAMAGE HAZARDS:

- Improper installation maintenance, or servicing of the air conditioner unit, or not following the above Safety Warnings can result in water damage to personal items or property.
- Insure that the unit is level to allow water to drain from the unit.
- Do not drill holes in the bottom of the drain pan or the underside of the unit.
- Failure to follow these instructions can result in result in damage to the unit and/or minor to serious property damage.

INTRODUCTION

This service manual is designed to be used in conjunction with the installation manuals provided with each unit.

This service manual was written to assist the professional HVAC service technician to quickly and accurately diagnose and repair any malfunctions of this product.

This manual, therefore, will deal with all subjects in a general nature. (i.e. All text will pertain to all models).

IMPORTANT: It will be necessary for you to accurately identify the unit you are servicing, so you can be certain of a proper diagnosis and repair. (See Unit Identification.)

Model Identification Guide

MODEL NUMBER	V	E	A	18	K	50	RT	L-B
SERIES V=Vertical Series								L; MARKETING SUFFIX Indicates Modification (subject to change)
E=Cooling with or without electric heat H=Heat Pump								B; ENGINEERING SUFFIX Indicates Modification (subject to change)
DESIGN SERIES A = 32" and 47" Cabinet								RT = Standard Wired Remote T-stat Operation
NOMINAL CAPACITY <u>A-Series (Btu/h)</u> 09 = 9,000 12 = 12,000 18 = 18,000 24 = 24,000								ELECTRIC HEATER SIZE <u>A-Series</u> 00 = No electric heat 25 = 2.5 KW 34 = 3.4 KW 50 = 5.0 KW 75 = 7.5 KW 10 = 10 KW
VOLTAGE K = 208/230V-1Ph-60Hz								

VPAK Serial Number Identification Guide

SERIAL NUMBER	A	A	A	N	00001
YEAR MANUFACTURED AK = 2010 AE = 2015 AA = 2011 AF = 2016 AB = 2012 AG = 2017 AC = 2013 AH = 2018 AD = 2014 AJ = 2019					PRODUCTION RUN NUMBER
					PRODUCT LINE N = VPAK
MONTH MANUFACTURED					
A = Jan		D = Apr		G = Jul	
B = Feb		E = May		H = Aug	
C = Mar		F = Jun		J = Sep	
		K = Oct		L = Nov	
		M = Dec			

Sample Nameplate (see your chassis nameplate)

<p>MODEL NO SERIAL NO FRIEDRICH AIR CONDITIONING CO. SAN ANTONIO, TEXAS</p> <p>VOLTS: VOLTAGE RANGE: REFRIG CHARGE: DESIGN PRESSURE: COOLING: BTU/HR SEER: COP: HEAT PUMP BTU/HR: TOTAL COOLING AMPS: TOTAL ELEC. HEAT AMPS: ELECTRIC HEAT WATTS:</p> <p><small>FOR PERMANENTLY CONNECTED UNITS ONLY: COMP: PLA LRA MOTOR: FLA HP HEATER AMPS: MIN. CKT AMP -0 USE -1 MAX. TIME DELAY FUS OR HACR TYPE CIRCUIT BREAKER.</small></p> <p><small>GENERAL UNIT INFORMATION: MAX OUTLET AIR TEMPERATURE: 200°F MAX EXTERNAL STATIC PRESSURE ELECTRIC HEAT: .5 IN. WATER "O" CLEARANCE TO COMBUSTIBLE MATERIAL</small></p> <p>USE ON SINGLE OUTLET CIRCUIT ONLY</p>	<h2 style="margin: 0;">WARNING</h2> <p style="margin: 5px 0;">ELECTRICAL SHOCK AND MOVING PARTS HAZARD CAN CAUSE INJURY OR DEATH</p> <p style="margin: 5px 0;">PULL OUT AND DISCONNECT HEAT CUT OFF ON THE FRONT OF THIS UNIT TO DISABLE POWER BEFORE SERVICING.</p> <div style="text-align: center; margin-top: 10px;"> </div>	<div style="text-align: center;"> </div> <p style="text-align: center;">LISTED 120524 HEATING AND COOLING EQUIPMENT</p> <p>APPLICABLE PATENTS: US 6,065,296</p> <p>NY MEA NO.: 295-00-E USE ONE OF THE FOLLOWING ITEMS FROM EACH CATEGORY TO COMPLETE THE ASSEMBLY</p> <p>WALL PLENUM: VPAWP1 -8 VPAWP1 -14 OUTDOOR GRILLE VPAL2 INDOOR GRILLE VPRG1 VPRG2 VPRG5</p>
---	---	---

ELECTRICAL REQUIREMENTS

⚠ WARNING



ELECTRIC SHOCK HAZARD

Turn off electric power before service or installation. All electrical connections and wiring MUST be installed by a qualified electrician and conform to the National Electrical Code and all local codes which have jurisdiction. Failure to do so can result in personal injury and/or death.

NOTICE

Not following the previous WARNING could result in fire or electrically unsafe conditions which could cause moderate or serious property damage. Read, understand and follow the previous warning.

Wire Size	Use ONLY wiring size recommended for single outlet branch circuit.
Fuse/Circuit Breaker	"Use ONLY time delayed fused disconnect or HACR type circuit breaker as indicated on the unit's rating plate. Proper current protection to the unit is the responsibility of the owner".
Grounding	Unit MUST be grounded from branch circuit to unit, or through separate ground wire provided on permanently connected units. Be sure that branch circuit outlet is grounded.
Wire Sizing	Use recommended wire size given in tables and install a single branch circuit. All wiring must comply with local and national codes. NOTE: Use copper conductors only.

Note: All field wiring must comply with NEC and local codes. It is the responsibility of the installer to insure that the electrical codes are met.

All 208/230v chassis must be hard wired with properly sized breaker. See nameplate for specific chassis electrical requirements. See below for unit wiring. For wall thermostat wiring, see page 12. Use HACR type breakers to avoid nuisance trips. All field wiring must be done in accordance with NEC and local codes.

Supply voltage

Supply voltage to the unit should be a nominal 208/230 volts. It must be between 197 volts and 253 volts. Supply voltage to the unit should be checked WITH THE UNIT IN OPERATION. Voltage readings outside the specified range can be expected to cause operating problems. Their cause MUST be investigated and corrected.

For VPAK Cool with Electric Heat 9-18K

Electrical Data

	VEA09K			VEA12K			VEA18K		
	2500/2050	3400/2780	5000/4090	2500/2050	3400/2780	5000/4090	2500/2050	3400/2780	5000/4090
Heater Watts	2500/2050	3400/2780	5000/4090	2500/2050	3400/2780	5000/4090	2500/2050	3400/2780	5000/4090
Voltage	230/208			230/208			230/208		
Heating BTU/h	8500/7000	11600/9500	17000/13900	8500/7000	11600/9500	17000/13900	8500/7000	11600/9500	17000/13900
Heating Current (Amps)	10.9/9.9	14.8/13.4	21.7/19.7	10.9/9.9	14.8/13.4	21.7/19.7	10.9/9.9	14.8/13.4	21.7/19.7
Minimum Circuit Ampacity	15	19.9	28.6	15	19.9	28.6	15	19.9	28.6
Branch Circuit Fuse (Amps)	15	20	30	15	20	30	15	20	30
LRA - Compressor (Amps)	22	22	22	30	30	30	42	42	42
Cooling Current (Amps)	4.2/4.4	4.2/4.4	4.2/4.4	5.2/5.4	5.2/5.4	5.2/5.4	8.1/8.6	8.1/8.6	8.1/8.6
Basic heater Size	2.5 Kw	3.4 Kw	5.0 Kw	2.5 Kw	3.4 Kw	5.0 Kw	2.5 Kw	3.4 Kw	5.0 Kw
Power Connection	HARD WIRED			HARD WIRED			HARD WIRED		
Recommended Branch Circuit Wire Sizes **	14	12	10	14	12	10	14	12	10

* AWG-American Wire Gauge

For VPAK Heat Pumps 9-18K

Electrical Data

	VHA09K			VHA12K			VHA18K		
	2500/2050	3400/2780	5000/4090	2500/2050	3400/2780	5000/4090	2500/2050	3400/2780	5000/4090
Heater Watts	2500/2050	3400/2780	5000/4090	2500/2050	3400/2780	5000/4090	2500/2050	3400/2780	5000/4090
Voltage	230/208			230/208			208/230		
Heating BTU/h	8500/7000	11600/9500	17000/13900	8500/7000	11600/9500	17000/13900	8500/7000	11600/9500	17000/13900
Heating Current (Amps)	10.9/9.9	14.8/13.4	21.7/19.7	10.9/9.9	14.8/13.4	21.7/19.7	10.9/9.9	14.8/13.4	21.7/19.7
Minimum Circuit Ampacity	15	19.9	28.6	15	19.9	28.6	15	19.9	28.6
Branch Circuit Fuse (Amps)	15	20	30	15	20	30	15	20	30
LRA - Compressor (Amps)	18.5	18.5	18.5	26	26	26	42	42	42
Cooling Current (Amps)	4.1/4.3	4.1/4.3	4.1/4.3	5.3/5.5	5.3/5.5	5.3/5.5	8.2/8.6	8.2/8.6	8.2/8.6
Basic heater Size	2.5 Kw	3.4 Kw	5.0 Kw	2.5 Kw	3.4 Kw	5.0 Kw	2.5 Kw	3.4 Kw	5.0 Kw
Power Connection	HARD WIRED			HARD WIRED			HARD WIRED		
Recommended Branch Circuit Wire Sizes	14	12	10	14	12	10	14	12	10

* AWG-American Wire Gauge

AWG — American Wire Gauge

* Single circuit from main box.

** Based on copper wire, single insulated conductor at 60°C

For VPAK Cool with Electric Heat 24K

For VPAK Heat Pumps 24K

Electrical Data										
Heater Watts	VEA24K					VHA24K				
	2500/2050	3400/2780	5000/4090	7500/6135	10000/8180	2500/2050	3400/2780	5000/4090	7500/6135	10000/8180
Voltage	230/208					230/208				
Heating BTU/h	8500/7000	11600/9500	17000/13900	25598/20939	34130/27918	8500/7000	11600/9500	17000/13900	25598/20939	34130/27918
Heating Current (Amps)	10.9/9.9	14.8/13.4	21.7/19.7	32.6/29.5	43.5/39.3	10.9/9.9	14.8/13.4	21.7/19.7	32.6/29.5	43.5/39.3
Minimum Circuit Ampacity	17.2/15.9	22.1/20.3	30.7/28.1	44.3/40.3	57.9/52.7	17.2/15.9	22.1/20.3	30.7/28.1	44.3/40.3	57.9/52.7
Branch Circuit Fuse (Amps)	25	25	30	45	60	25	25	30	45	60
LRA - Compressor (Amps)	34.8	34.8	34.8	34.8	34.8	34.8	34.8	34.8	34.8	34.8
Cooling Current (Amps)	10.0/10.4	10.0/10.4	10.0/10.4	10.0/10.4	10.0/10.4	10.6/10.9	10.6/10.9	10.6/10.9	10.6/10.9	10.6/10.9
Basic heater Size	2.5 Kw	3.4 Kw	5.0 Kw	7.5 Kw	10.0 Kw	2.5 Kw	3.4 Kw	5.0 Kw	7.5 Kw	10.0 Kw
Power Connection	HARD WIRED					HARD WIRED				
Recommended Branch **Circuit Wire Sizes* AWG - American Wire Gauge	10	10	10	6	4	10	10	10	6	4

AWG — American Wire Gauge

* Single circuit from main box.

** Based on copper wire, single insulated conductor at 60°C

Chassis Specifications

Model 2011	VEA09K	VEA12K	VEA18K	VEA24K	VHA09K	VHA12K	VHA18K	VHA24K
COOLING DATA								
COOLING BTU/h	9400/9000	11500/11200	17000/16500	23000/22700	9200/9000	11500/11200	17000/16800	23000/22800
POWER (W)	959	1173	1888	2421	939	1186	1868	2527
EER	9.8/9.8	9.8/9.8	9.0/9.0	9.5/9.5	9.8/9.8	9.7/9.7	9.1/9.1	9.1/9.1
SENSIBLE HEAT RATIO	0.74	0.72	0.70	0.70	0.74	0.72	0.70	0.70
HEAT PUMP DATA								
HEATING BTU/h	N/A				8500	10800	16000	20000
COP @ 47F	N/A				3.0	3.0	3.0	3.0
HEATING POWER (W)	N/A				830	1055	1563	1953
HEATING CURRENT (A)	N/A				3.6	4.9	7.5	9.4
ELECTRICAL DATA								
VOLTAGE (1 PHASE, 60 Hz)	230/208	230/208	230/208	230/208	230/208	230/208	230/208	230/208
VOLT RANGE	253-198	253-198	253-198	253-198	253-198	253-198	253-198	253-198
COOLING CURRENT (A)	4.2/4.4	5.2/5.4	8.1/8.5	10.0/10.4	4.1/4.3	5.3/5.5	8.2/8.5	10.6/10.8
AMPS L.R.	19.8	30	42	34.8	18.5	26	42	34.8
AMPS F.L.	3.5	4.5	7.8	9.5	3.5	5	7.8	9.5
INDOOR MOTOR (HP)	1/4	1/4	1/4	1/4	1/4	1/4	1/4	1/4
INDOOR MOTOR (A)	1.2	1.2	1.2	1.94	1.2	1.2	1.2	1.94
OUTDOOR MOTOR (HP)	N/A				N/A			
OUTDOOR MOTOR (A)	N/A				N/A			
AIRFLOW DATA								
INDOOR CFM*	300	350	450	610	300	420	450	610
VENT CFM	60	60	60	60	60	60	60	60
MAX. ESP	.3"	.3"	.3"	.4"	.3"	.3"	.3"	.4"
PHYSICAL								
DIMENSIONS (W x D x H)	23x23x32	23x23x32	23x23x32	23x23x47	23x23x32	23x23x32	23x23x32	23x23x47
NET WEIGHT (LBS)	114	124	144	167	114	125	144	167
SHIPPING WEIGHT (LBS)	125	135	155	220	125	135	155	220
R410A CHARGE (oz)	33.5	35.5	48	65	39	42	52	74

* Normal Value Wet Coil @ .1"ESP.

TECHNICAL SERVICE DATA

Cooling Performance Data

SERVICE DATA Cooling¹	ELECTRICAL RATINGS		INDOOR COIL TEMPERATURE °F		OUTDOOR COIL TEMPERATURE °F	Discharge Line Temperature °F	Suction Line Temperature °F	Super Heat	Sub-Cooling	OPERATING PRESSURES		Refrigerant Charge R-410A - Oz.
	Voltage	Amps	Supply Air	Temperature Drop Δ						Suction	Discharge	
VEA09K**RTL	230/208	4.2	58	22	118	156	66	9	24	151	389	33.5
VEA12K**RTL	230/208	5.2	57	23	116	158	59	12	17	141	396	32.0
VEA18K**RTL	230/208	8.1	55	25	127	180	60	12	28	135	455	48.0
VEA24K**RTL	230/208	10.0	55	25	125	170	61	10	34	135	440	65.0
VHA09K**RTL	230/208	4.1	57	23	117	155	62	12	20	155	405	39.0
VHA12K**RTL	230/208	5.3	55	25	119	165	65	15	23	145	450	42.0
VHA18K**RTL	230/208	8.2	51	29	129	190	60	14	35	133	465	45.0
VHA24K**RTL	230/208	10.6	51	29	128	174	60	12	32	140	480	74.0

¹Test Conditions: 80° F, Room Air Temperature with 50% Relative Humidity, and 95° F, Outdoor Air Temperature with 40% Relative Humidity

**Denotes Heater KW - Numbers Vary

Extended Cooling Performance Data

VEA - EXTENDED COOLING PERFORMANCE																					
Model #		OUTDOOR DRY BULB TEMP. (DEGREES F AT 40% R.H.)																			
		75				85				95				105				110			
		INDOOR WET BULB TEMP. (DEGREES F AT 80 F D.B.)																			
		72	67	62	72	67	62	72	67	62	72	67	62	72	67	62					
VEA09	BTUh	11054	10631	9842	10528	9926	9156	10114	9400	8319	9475	8413	7417	8954	7835	6914					
	WATTS	783	795	804	853	861	872	959	959	959	1037	1036	1039	1084	1083	1087					
	AMPS	3.5	3.5	3.5	3.7	3.8	3.8	4.2	4.20	4.2	4.5	4.5	4.5	4.7	4.7	4.7					
	SHR	0.51	0.69	0.93	0.52	0.71	0.95	0.52	0.74	0.95	0.53	0.78	0.96	0.55	0.81	0.95					
VEA12	BTUh	13524	13007	12041	12880	12144	11201	12374	11500	10178	11592	10293	9074	10954	9585	8458					
	WATTS	957	972	983	1043	1053	1066	1173	1173	1173	1268	1267	1270	1325	1325	1330					
	AMPS	4.3	4.3	4.4	4.6	4.7	4.7	5.2	5.20	5.2	5.6	5.6	5.6	5.9	5.9	5.9					
	SHR	0.49	0.67	0.90	0.50	0.70	0.92	0.51	0.72	0.92	0.52	0.76	0.93	0.53	0.79	0.93					
VEA18	BTUh	19992	19227	17799	19040	17952	16558	18292	17000	15045	17136	15215	13413	16193	14170	12504					
	WATTS	1541	1565	1582	1678	1695	1716	1888	1888	1888	2041	2039	2045	2133	2132	2140					
	AMPS	6.7	6.7	6.8	7.2	7.2	7.3	8.1	8.10	8.1	8.7	8.7	8.7	9.1	9.1	9.1					
	SHR	0.48	0.65	0.88	0.49	0.68	0.89	0.49	0.70	0.90	0.50	0.74	0.90	0.52	0.76	0.9					
VEA24	BTUh	27048	26013	24081	25760	24288	22402	24748	23000	20355	23184	20585	18147	21908	19171	16917					
	WATTS	1976	2007	2029	2152	2174	2201	2421	2421	2421	2617	2615	2622	2736	2735	2744					
	AMPS	8.3	8.3	8.4	8.9	9.0	9.0	10.0	10.00	10.1	10.8	10.8	10.8	11.3	11.3	11.3					
	SHR	0.48	0.65	0.88	0.49	0.68	0.89	0.49	0.70	0.9	0.5	0.74	0.9	0.52	0.76	0.9					
									RATING POINT												
									ARI 310/380												

VHA - EXTENDED COOLING PERFORMANCE																					
Model #		OUTDOOR DRY BULB TEMP. (DEGREES F AT 40% R.H.)																			
		75				85				95				105				110			
		INDOOR WET BULB TEMP. (DEGREES F AT 80 F D.B.)																			
		72	67	62	72	67	62	72	67	62	72	67	62	72	67	62					
VHA09	BTUh	10819	10405	9632	10304	9715	8961	9899	9200	8142	9274	8234	7259	8763	7668	6767					
	WATTS	766	778	787	835	843	854	939	939	939	1015	1014	1017	1061	1061	1064					
	AMPS	3.4	3.4	3.5	3.7	3.7	3.7	4.1	4.10	4.1	4.4	4.4	4.4	4.6	4.6	4.6					
	SHR	0.51	0.69	0.93	0.52	0.71	0.95	0.52	0.74	0.95	0.53	0.78	0.96	0.55	0.81	0.95					
VHA12	BTUh	13524	13007	12041	12880	12144	11201	12374	11500	10178	11592	10293	9074	10954	9585	8458					
	WATTS	968	983	994	1054	1065	1078	1186	1186	1186	1282	1281	1284	1340	1340	1344					
	AMPS	4.4	4.4	4.5	4.7	4.7	4.8	5.3	5.30	5.3	5.7	5.7	5.7	6	6	6					
	SHR	0.49	0.67	0.9	0.5	0.7	0.92	0.51	0.72	0.92	0.52	0.76	0.93	0.53	0.79	0.93					
VHA18	BTUh	19992	19227	17799	19040	17952	16558	18292	17000	15045	17136	15215	13413	16193	14170	12504					
	WATTS	1524	1549	1565	1661	1677	1698	1868	1868	1868	2019	2017	2023	2111	2110	2117					
	AMPS	6.8	6.8	6.9	7.3	7.3	7.4	8.2	8.20	8.2	8.8	8.8	8.9	9.2	9.2	9.3					
	SHR	0.48	0.65	0.88	0.49	0.68	0.89	0.49	0.70	0.90	0.50	0.74	0.90	0.52	0.76	0.9					
VHA24	BTUh	27048	26013	24081	25760	24288	22402	24748	23000	20355	23184	20585	18147	21908	19171	16917					
	WATTS	2062	2095	2118	2247	2269	2297	2527	2527	2527	2732	2729	2737	2856	2854	2864					
	AMPS	8.8	8.8	8.9	9.4	9.5	9.5	10.5	10.60	10.7	11.4	11.4	11.4	11.9	11.9	12					
	SHR	0.48	0.65	0.88	0.49	0.68	0.89	0.49	0.70	0.90	0.50	0.74	0.90	0.52	0.76	0.9					
									RATING POINT												
									ARI 310/380												

ELECTRONIC CONTROL BOARD FEATURES

The new Friedrich Vert-I-Pak has state of the art features to improve guest comfort and conserve energy. Through the use of specifically designed control software, Friedrich has accomplished what other Manufacturer's have only attempted – a quiet, dependable, affordable and easy to use Vert-I-Pak.

Below is a list of standard features on every Friedrich VPAK and their benefit to the owner.

Quiet Start/Stop Fan Delay	The fan start and stop delays prevent abrupt changes in room acoustics due to the compressor energizing or stopping immediately. Upon call for cooling or heating the unit fan will run for five seconds prior to energizing the compressor. Also, the fan off delay allows for "free cooling" by utilizing the already cool indoor coil to its maximum capacity by running for 30 seconds after the compressor.
Remote Thermostat Operation	VPAK units are controlled by a wired remote wall thermostat.
Internal Diagnostic Program	The new Friedrich digital VPAK features a self diagnostic program that can alert maintenance to component failures or operating problems. The internal diagnostic program saves properties valuable time when diagnosing running problems.
Service Error Code Storage	The self diagnosis program will also store error codes in memory if certain conditions occur and correct themselves such as extreme high or low operating conditions or activation of the room freeze protection feature. Storing error codes can help properties determine if the unit faced obscure conditions or if an error occurred and corrected itself.
Random Compressor Restart	Multiple compressors starting at once can often cause electrical overloads and premature unit failure. The random restart delay eliminates multiple units from starting at once following a power outage or initial power up. The compressor delay will range from 180 to 240 seconds.
Heat Pump Units Digital Defrost Thermostat	The new Friedrich VPAK uses a digital thermostat to accurately monitor the outdoor coil conditions to allow the heat pump to run whenever conditions are correct. Running the VPAK in heat pump mode save energy and reduces operating costs. The digital thermostat allows maximization of heat pump run time.
Instant Heat Heat Pump Mode	Heat pump models will automatically run the electric heater during compressor lock-out to quickly provide heat when initially energized, then return to heat pump mode. This ensures that the room is heated quickly without the usual delay associated with heat pump units.
Room Air Sampling Feature	The room air sampling feature maintains a balanced temperature throughout the room by circulating the air for 90 seconds once every 9 minutes that the unit is not running when it is set to cooling or heating mode. By circulating the air, the unit can detect hot or cold areas in the room and operate the unit to cool or warm the room as necessary. This function is only available when the fan mode is set to 'AUTO' during COOL or HEAT Mode.
Desk Control Ready	All electronic VPAK units have low voltage terminals ready to connect a desk control energy management system. Controlling the unit's on/off operation from a remote location like the front desk can reduce energy usage and requires no additional accessories at the VPAK.
Indoor Coil Frost Sensor	The frost sensor protects the compressor from damage in the event that airflow is reduced or low outdoor temperatures cause the indoor coil to freeze. When the indoor coil reaches 30°F the compressor is disabled and the fan continues to operate based on demand. Once the coil temperature returns to 45°F the compressor returns to operation.
Auxiliary Fan Ready	The VPAK features a 24V AC terminal for connection to a relay that may be used to operate an auxiliary fan to transfer air to adjoining rooms. Auxiliary fans can provide air conditioning to odd shaped rooms.

ELECTRONIC CONTROL SEQUENCE OF OPERATION

Note: Unit is operated by a wired remote wall t-stat which is connected to an electronic control board at the VPAK unit.

Compressor and Reversing Valve Control

Active Mode	Compressor	Reversing Valve State *
Cooling	On	De-Energized
Heat - Heat Pump (Compressor Heat)	On	Energized
Heat Pump Electric Heat	Off	Energized
Heat - Electric Heat / Cool Units	Off	De-Energized
Fan Only	Off	*

* The Reversing valve stays in the last state until a call for heat or cooling.

Cooling Mode

Once the ambient temperature rises past the cool demand set point of the t-stat, and if the compressor is not locked out, the cooling cycle begins. The fan is started 5 seconds prior to the compressor. Once the ambient temperature has been lowered to the cool set point the cooling cycle starts to terminate by shutting off the compressor. After a 30 seconds delay, the fan is shut off.

Heating Mode Control Operation

There are two heating methods: Heat Pump and Electric Resistance Heat.

There are 2 types of units that provide heating:

Heat Pump with Electric Heat and Cool with Electric Heat.

Heat Mode in Cool with Electric Heat Units

When the t-stat is in the Heat Mode, if the indoor ambient temperature is below the heat set point, the fan turns on 5 seconds prior then the electric heat will turn on. When the t-stat is satisfied, the electric heat will turn off. The fan turns off 15 seconds later.

Heat Pump With Electric Heat Operation

This heating has two heating methods. If the ambient indoor temperature is below the heat set point and the compressor is not locked out, the compressor turns on. If the ambient temperature rises above the t-stat's heat set point, the compressor turns off.

If the Compressor is Locked Out on the 3 Minute Time Delay and Electric Heat is Available

1. The control turns on the electric heat until the compressor is not locked out.
2. After lockout, the control turns off the electric heat, waits 5 seconds, then turns on the compressor.
(The wired remote wall t-stat's time delay may override this feature).

Condition 1

If the outdoor coil temperature sensor drops to 30 °F or less for 2 consecutive minutes, the unit will switch to electric heat if available. Thereafter, the unit will switch back to Heat Pump heat until the outdoor coil temperature sensor rises to 45 °F or greater.

Compressor Lock Out Time

The lockout feature ensures that the compressor is de-energized for a period of time. The timer varies randomly from 180 to 240 seconds

The compressor lockout is initiated every time the compressor is "off" due to:

- (1) Satisfying the T-stat temperature set point
- (2) Changing mode to fan only or heat
- (3) Turning the unit off
- (4) Power is restored after failure
- (5) Line power is restored from a brown out condition

Cooling Fan Delay

This is only for t-stat Fan Auto Mode only.

When unit cycles cooling ON – starts the fan 5 seconds EARLY. When unit cycles cooling OFF – DELAYS the fan off for 30 seconds

Heating Fan Delay

This is only for Fan Auto Mode (Fan cycles with cool/heat operation) and not for continuous fan mode. When unit cycles Heating ON – starts the fan 5 seconds EARLY. When unit cycles Heating OFF – DELAYS the fan off for 15 seconds.

Continuous fan operation enables fan to run continuously.

Fan Speed Change Delay

Relay activation is delayed by a minimum number of seconds. The default for this value is 2 seconds and is used to eliminate relay chatter.

Room Air Sampling Feature

The room air sampling feature maintains a balanced temperature throughout the room by circulating the air for 90 seconds once every 9 minutes that the unit is not running when it is set to cooling or heating mode. By circulating the air, the unit can detect hot or cold areas in the room and operate the unit to cool or warm the room as necessary. This function is only available when the fan mode is set to 'AUTO' during COOL or HEAT Mode.

Low Voltage Interface Connections

All Vert-I-Pak units have a low voltage interface connector through which a Remote Wall Thermostat, Desk Control and Auxiliary Fan's Relay can be connected. The interface connector is located on the electronic control board.

Figure 1 Interface Connector Location

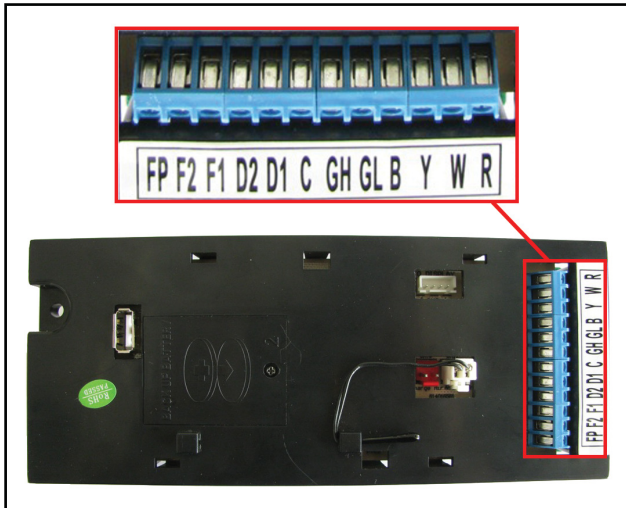

Questions concerning proper connections to the unit should be directed to the factory.

Table 1

Interface Connector Definitions	
FP	Factory use only. (Ensure there is no jumper at FP and F2)
F2	Used with F1 to provide 24 VAC to external fan relay. (Ensure there is no jumper at FP and F2)
F1	Used with F2 to provide 24 VAC to external fan relay.
D2	Used with D1 for desk control on or off operation.
D1	Used with D2 for desk control on or off operation.
C	Common Ground Terminal
GH	Call for high fan
GL	Call for low fan
B	Call for heat pump reversing valve
Y	Call for compressor
W	Call for heating
R	24V Power from Electronic Control to Wall

Remote Wall Thermostat

All Friedrich Vert-I-Pak units are factory configured to be controlled by using a single stage heat/cool remote wired wall mounted thermostat.

Thermostat Selection

Friedrich recommends the use of the Friedrich **RT4 and RT6**. These thermostats are single stage heat/cool, manual changeover. The **RT4** is a digital display thermostat with single speed fan control. The **RT6** features a digital display, two fan speed selection, temperature limiting, status indicator light, room temperature offset, and backlight. Other thermostats may be used as long as they are **single stage heat/cool** and are configured correctly for the unit.

Thermostat terminals requirements:

For cooling with electric heat units: **C, R, G, Y, W.**

For heat pump units: **C, R, G, Y, W, B.**

For two fan speeds, thermostat must have 2 fan speed selection.

HEAT PUMP UNITS

During Heat Mode:

The B terminal must be continuously energized. The W terminal must have 24 VAC output to call for heat. The control board decides on whether to turn on the Heat Pump Heat (compressor) or Electric Heat. The Y terminal should not have 24 VAC output during heat mode.

Connecting a Remote Wall Thermostat

⚠ WARNING

ELECTRIC SHOCK HAZARD

Disconnect power to the unit before servicing. Failure to follow this warning could result in serious injury or death.

⚠ CAUTION

It is the installer's responsibility to ensure that all control wiring connections are made in accordance with the installation instructions.

Improper connection of the thermostat control wiring and/or tampering with the unit's internal wiring can void the equipment warranty.

Failure to follow these instructions can result in personal injury and damage to product or other property.

Connect the thermostat using Figure 1 and Table 1 as a guide.

Procedure (Ensure there is no jumper wire at FP and F2)

- 1) Disconnect power to the unit.
- 2) Unscrew and remove the electrical control box's cover.
- 3) Locate the Interface Connector (24 VAC terminal strip (See figure 1 at left).
- 4) Make the wire connections according to the configuration needed for your unit (see above or page 40 for wiring diagrams). Use #18 gauge wire size.
- 5) Once each wire is matched and connected, the unit is now ready to be controlled by the thermostat.
- 6) Reattach the electrical control box's cover.

Remote Wall Thermostat Location

The thermostat should not be mounted where it may be affected by drafts, discharge air from registers (hot or cold), or heat radiated from the sun appliances, windows etc.. The thermostat should be located about 5 Ft. above the floor in an area of average temperature, with good air circulation.

Mercury bulb type thermostats **MUST** be level to control temperature accurately to the desired set-point. Electronic digital type thermostats should be level for aesthetics.



Note: An improperly operating or poorly located remote wall thermostat can be the source of perceived equipment problems. A careful check of the thermostat's location and wiring must be made then to ensure that it is not the source of problems.

Desk Control

The unit's electronic control has built-in provisions for connection to an external switch to control power to the unit. The switch can be a central desk control system or even a normally open door switch.

For desk control operation, connect one side of the switch to the D1 terminal and the other to the D2 terminal (See page 12). Whenever the switch closes, the unit operation will stop.

Maximum Wire Length for Desk Control Switch

Wire Size	Maximum Length
#24	400 ft.
#22	600 ft.
#20	900 ft.
#18	1500 ft.
#16	2000 ft.

Auxiliary Fan Control

The electronic control also has the ability to control a 24 VAC relay to activate an auxiliary, or transfer fan. The outputs are listed as F1 and F2 on the interface connector (See page 12).

To connect the relay, simply wire one side of the relay to F1 and the other side to F2. Anytime that the fan runs, the terminals will send a 24 VAC signal to the relay. The relay must be 24 VAC, 50mA or less.

Note: The Desk Control, Auxiliary Fan relay and wires must be field supplied.

SERVICE

⚠ WARNING



ELECTRIC SHOCK HAZARD

Turn off electric power before service or installation.

Extreme care must be used, if it becomes necessary to work on equipment with power applied.

Failure to do so could result in serious injury or death.

⚠ CAUTION



CUT/SEVER HAZARD

Be careful with the sharp edges and corners. Wear protective clothing and gloves, etc.

Failure to do so could result in minor to moderate injury.

Servicing / Chassis Quick Changeouts

The chassis is designed for quick disconnect and change out. For minor electrical service, the control box cover lifts straight up after the screws & disconnect head are removed. For major electrical, refrigeration and fan service the chassis may be removed from utility closet.

To Remove the Chassis from the Closet:

- Disconnect the power coming into the unit from the main breaker panel or the closet mounted disconnect.
- Switch the wall Thermostat off.
- Pull the Power Disconnect located in the front of the chassis.
- Disconnect the electrical connection.
- Disconnect the duct work.
- Disconnect condensate drain on 9-18,000 BTU models.
- Slide the chassis out of the wall plenum.
- Lift the chassis out of the utility closet.

Warranty

All service work must be done by a qualified servicer. See Product Warranty, and consult your dealer or contractor for details

VPAK 9-18K BTU UNITS

COMPONENTS IDENTIFICATION



VPAK 24K BTU UNITS

COMPONENTS IDENTIFICATION

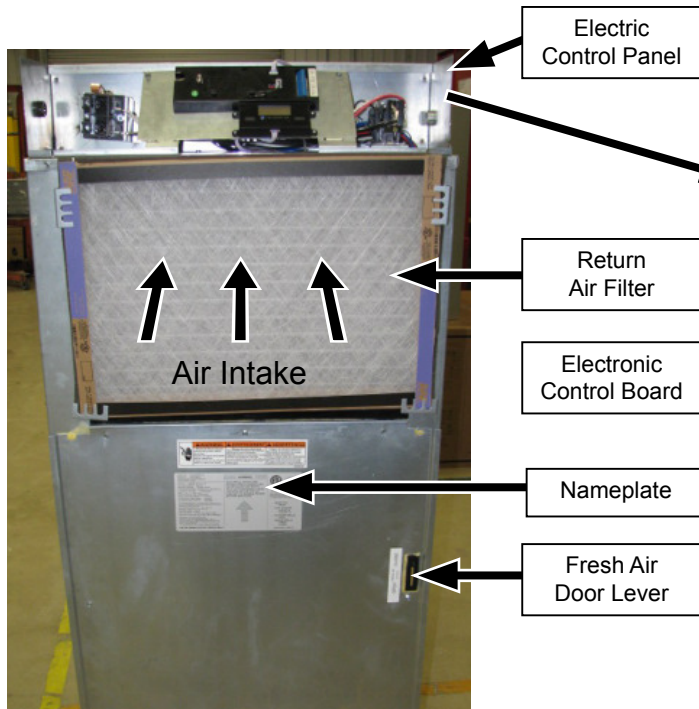

Front Side

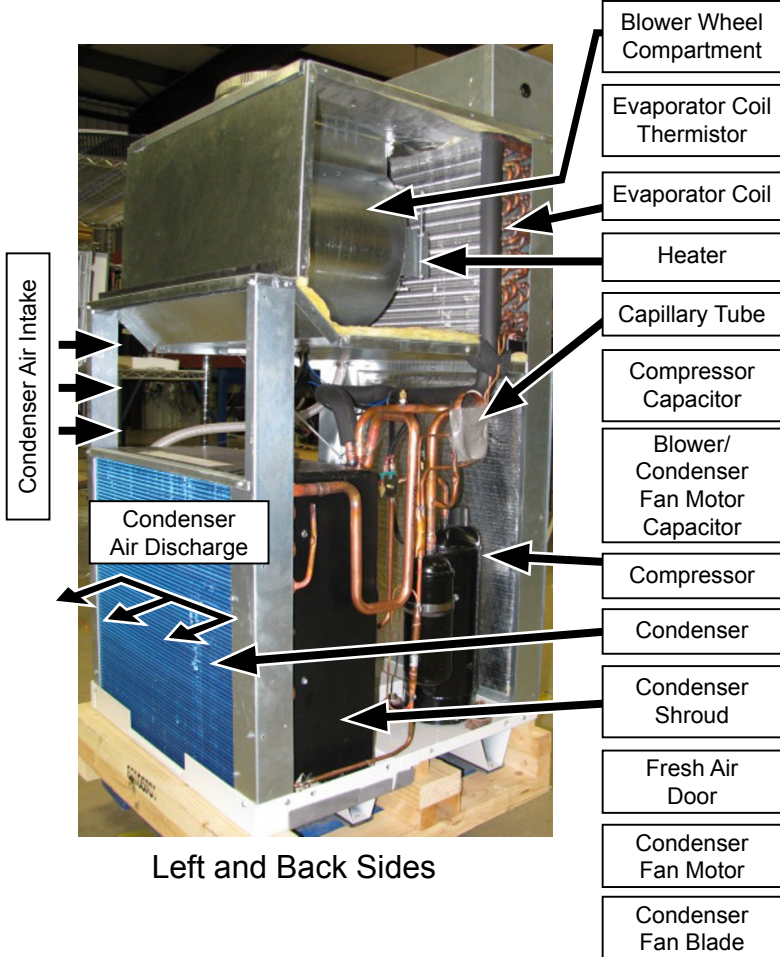
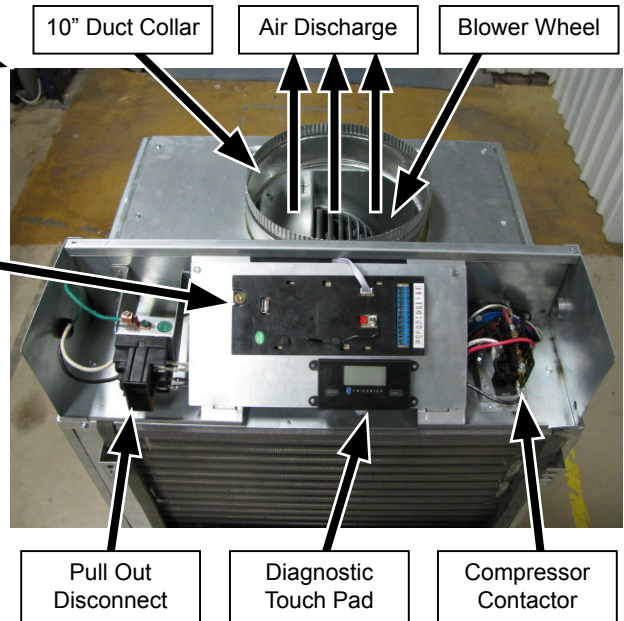

Left and Back Sides

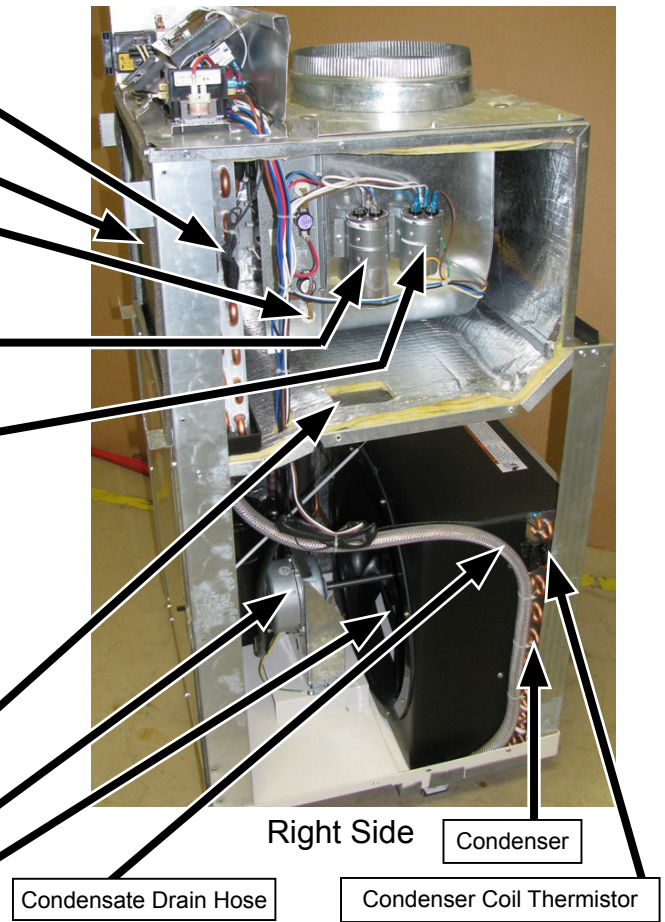

Right Side

Error Codes and Alarm Status

Unit Control Panel

The display shown below has four digits. The left two digits indicate the error code # (1 to 24), The On/Off icons above these two digits indicate the currents state of the error code. The right two digits show the history count (up to 99) of the associated error code. The display contains a maintenance icon (wrench) that will illuminate to indicate when the unit needs service. This wrench indicates an error code # is on (active). To find out which one, check all error codes.



Check Error Codes

1. Press the Enter key to activate the display.
2. Each press of the scroll key display the next error code.

Clear History Counters

1. Press & hold the Enter key and the Scroll Key for 6 seconds.

The chart below lists the possible error codes and their description:

Error Code	Problem	Action
1	Front Panel Button Stuck For More Than 20 Seconds	Continue to monitor for "OPEN" (Unstuck) switch. Do not process switch input.
2	Input Voltage Out of Specification (187 - 253)	Unit stops, open all relays until voltage is back within specs then resume operation.
3	Indoor Temperature Sensor is Open or Shorted	Unit defaults to 75°F in COOLING or 68°F in HEATING and will continue to operate if setting is below 75°F in cool mode or if above 68°F in heat mode.
4	Indoor Coil Temperature Sensor is Open or Shorted	The unit's control board defaults to 40°F. It will override the sensor and the unit will continue to operate.
5	Outdoor Coil Temperature Sensor is Open or Shorted	The unit defaults to 20°F, overriding the sensor. The unit will continue to operate. Using Elec Heat if available for HEATING. If not available, it will use HEAT PUMP if the outdoor temperature allows.
6	Outdoor Coil > (grater than) 175 F	The unit will shut down for 5 minutes. resume operation for 3 minutes. If test fails 3 times, the unit operation is locked out. See troubleshooting page 42. To reset, turn power off and on.
7	Indoor Coil < (less than) 30 F for 2 consecutive minutes	The compressor will turn off and the High Fan speed will run. When coil temp reaches 45°F the unit will resume operation after lockout time.
8	Unit Cycles > (greater than) 9 Times per hour	The unit will continue to operate and be monitored.
9	Unit Cycles < (less than) 3 Times per Hour	The unit will continue to operate and be monitored.
10	Not Applicable	Not Applicable
11	WallStat Problem or Connection Issue	The unit will not operate.
12	Not Applicable	Not Applicable
13	VPAK 24K Unit Only High Pressure Limit Switch is Open	If unit is cooling or heat pump is on, shut down compressor. Run high fan until switch closes, then resume operation. The third occurrence in 1 hour locks unit out. Applicable to 24K unit only. To reset, turn power off and on.
14	Not Applicable	Not Applicable
15	Heat Pump Error	If indoor coil temperature is less than ambient temperature for 3 minutes, the unit will use electric heat to satisfy the heating demand. Causes could be bad reversing valve, heat load too high.
16	Temperature beyond operating limits	Occurs if the indoor ambient temperature range falls below 0°F or greater than 130°F. The error code will remain on until the temperature reaches the operating range and then the unit will return to normal operation.
17	Equipment Doesn't Meet Minimum Configuration	The compressor must be enabled and have at least 2 fan speeds.
18	Not Applicable	Not Applicable
19	Not Applicable	Not Applicable
20	Not Applicable	Not Applicable
21	Not Applicable	Not Applicable
22	(Not an error code) Outdoor Coil Temperature < 30 F for 2 consecutive minutes	Unit will use electric heat to satisfy heating demands until the temperature equals or exceeds 45°F. Applicable for Heat Pump models only.
23	Not Applicable	Not Applicable
24	Not Applicable	Not Applicable

COMPONENTS TESTING

Testing the Diagnostic Service Module

Testing the Electronic Control Board

⚠ WARNING	
	ELECTRIC SHOCK HAZARD Turn off electric power before service or installation. Extreme care must be used, if it becomes necessary to work on equipment with power applied. Failure to do so could result in serious injury or death.

If the Diagnostic Service Module does not turn on:

1. Make sure there is 208/230 VAC to the unit and that it is turned on.
2. Disconnect the diagnostic service module's wire harness on the control board.
3. Using a voltmeter, check the first two pins to the left of the female connector (see picture below). There should be up to 5VDC.
4. If there is no voltage, replace the electronic control board.
5. If there is voltage, check the wire harness and connections at the electronic control board and the diagnostic service module.
6. If the connections and the wire harness are good, replace the diagnostic service module.

Diagnostic Service Module

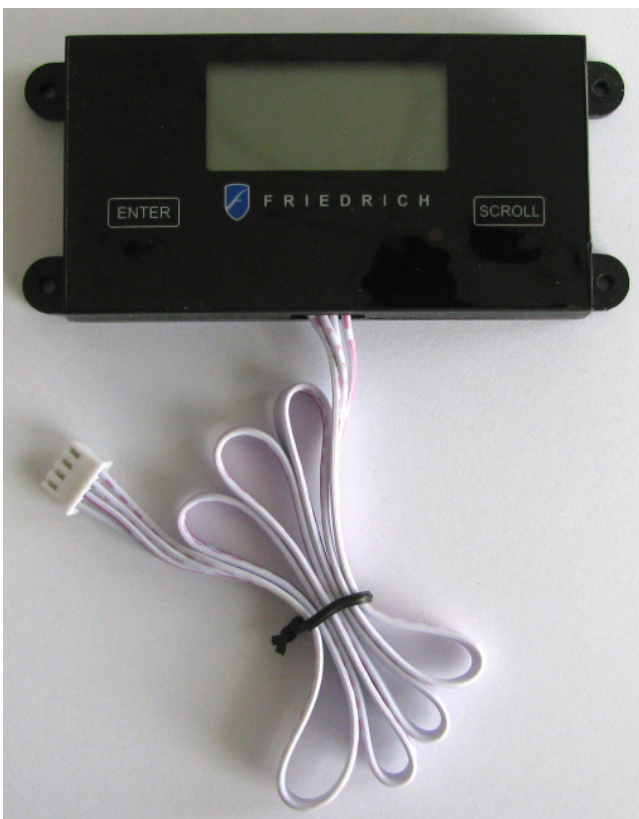

Service Module Connector



Test here up to 5VDC.
If no voltage, replace board.
If there is 5VDC, check connections and cable. If OK, replace service module.

ELECTRONIC CONTROL BOARD COMPONENTS IDENTIFICATION AND TESTING (Continued) (See wiring diagrams pages 41-46)

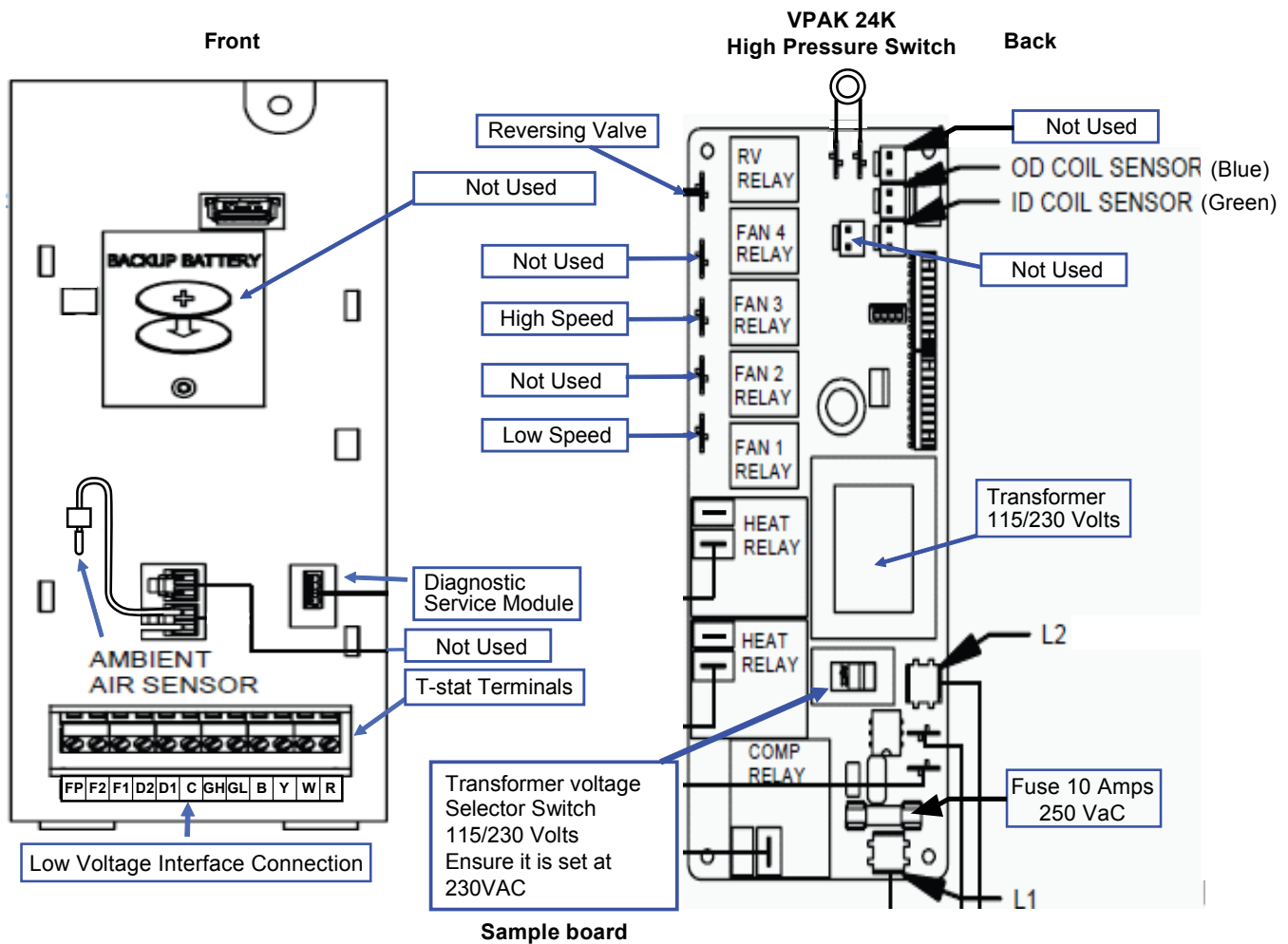

1. Test for power at L1 and L2 for 208/230 VAC. (Ensure the transformer voltage selector switch is set for 230 VAC)
2. Test the 10 amp/250 VAC fuse for continuity.

FOR THE FOLLOWING TESTS, ENSURE THE UNIT IS IN THE APPROPRIATE SETTINGS FOR THE TEST BEING PERFORMED. ENSURE THERE ARE NO ERROR CODES ACTIVE.

3. Testing the compressor relay and heat relays:
Test for power in and power out. If there is power in and no power out, replace the electronic control board. (208/230 to L2)
4. Testing the fan and reversing valve relays:
Test for power at the reversing valve and fan relays 1 or 3. (208/230 to L2)
5. Testing the transformer:
Test the low voltage terminal strip at:
R and C for 24 VAC
F2 and F1 for 24 VAC
D2 and D1 for 24 VAC
Test the service module connector for 5 VDC (see prior page)
Test the connectors for the thermistors for up to 5 VDC
If there is no voltage at any of the above, replace electronic control board.
6. Testing the thermistors:
Disconnect the thermistor and test for resistance value (see page 35)
7. Testing the high pressure switch (VPAK 24K only)
Test for 24 VAC at board, if there is no voltage, replace the electronic control.
Test the pressure switch for continuity, if none, replace it (switch is normally closed)

COMPONENTS TESTING (Continued)

BLOWER / FAN MOTOR

A single phase permanent split capacitor motor is used to drive the evaporator blower and condenser fan. A self-resetting overload is located inside the motor to protect against high temperature and high amperage conditions.

⚠ WARNING	
	<p>ELECTRIC SHOCK HAZARD Disconnect power to the unit before servicing. Failure to follow this warning could result in serious injury or death.</p>

BLOWER / FAN MOTOR TEST

1. Visually inspect the motor's wiring, housing etc., and determine that the capacitor is serviceable.
2. Make sure the motor has cooled down.
3. Disconnect the fan motor wires from the control board.
4. Test for continuity between the windings also, test to ground.
5. If any winding is open or grounded replace the motor.

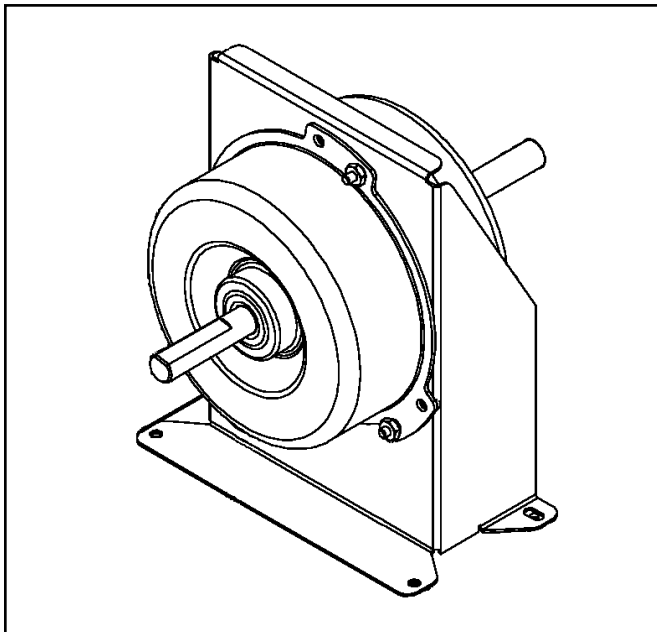

CAPACITORS

⚠ WARNING	
	<p>ELECTRIC SHOCK HAZARD Turn off electric power before servicing. Discharge capacitor with a 20,000 Ohm 2 Watt resistor before handling. Failure to do so may result in personal injury, or death.</p>

Many motor capacitors are internally fused. Shorting the terminals will blow the fuse, ruining the capacitor. A 20,000 ohm 2 watt resistor can be used to discharge capacitors safely. Remove wires from capacitor and place resistor across terminals. When checking a dual capacitor with a capacitor analyzer or ohmmeter, both sides must be tested.

Capacitor Check with Capacitor Analyzer

The capacitor analyzer will show whether the capacitor is "open" or "shorted." It will tell whether the capacitor is within its micro farads rating and it will show whether the capacitor is operating at the proper power-factor percentage. The instrument will automatically discharge the capacitor when the test switch is released.

Capacitor Connections

The starting winding of a motor can be damaged by a shorted and grounded running capacitor. This damage usually can be avoided by proper connection of the running capacitor terminals.

From the supply line on a typical 230 volt circuit, a 115 volt potential exists from the "R" terminal to ground through a possible short in the capacitor. However, from the "S" or start terminal, a much higher potential, possibly as high as 400 volts, exists because of the counter EMF generated in the start winding. Therefore, the possibility of capacitor failure is much greater when the identified terminal is connected to the "S" or start terminal. The identified terminal should always be connected to the supply line, or "R" terminal, never to the "S" terminal.

When connected properly, a shorted or grounded running capacitor will result in a direct short to ground from the "R" terminal and will blow the line fuse. The motor protector will protect the main winding from excessive temperature.

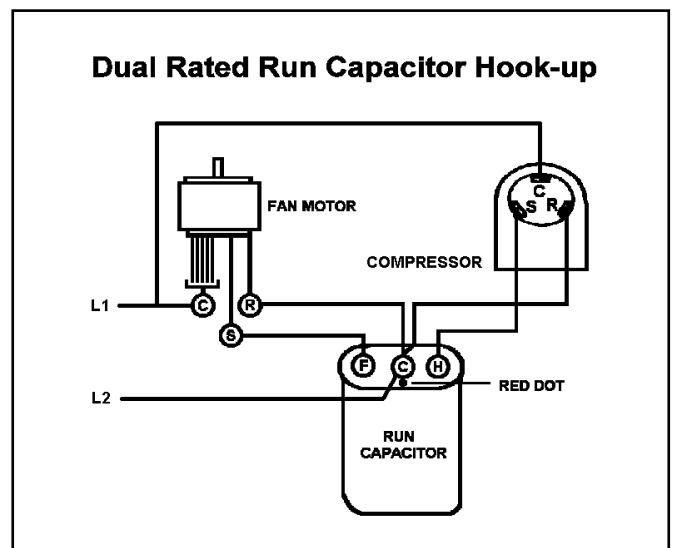

COMPONENTS TESTING (Continued)

HEATER ELEMENTS AND LIMIT SWITCHES' SPECIFICATIONS

All heat pumps and electric heat models are equipped with a heating element and a limit switch (bimetal thermostat). The limit is in series with the element and will interrupt the power at a designed temperature.

Should the blower motor fail, filter become clogged or air-flow be restricted etc., the high limit switch will open and interrupt the power to the heater before reaching an unsafe temperature condition.

VPAK 9K, 12K and 18K BTUs Models:

2.5 KW, 230 V, Resistance 18.61 Ohms + - 5%.

Has 1 Limit Switch, Opens at **120° F**, Closes at **90° F**, It has a One Time Open Temp. of **145° F**.

3.4 KW, 230 V, Resistance 13.68 Ohms + - 5%.

Has 1 Limit Switch, Opens at **120° F**, Closes at **90° F**, It has a One Time Open Temp. of **145° F**.

5 KW, 230 V, Resistance 9.31 Ohms + - 5%.

Has 1 Limit Switch, Opens at **130° F**, Closes at **100° F**, It has a One Time Open Temp. of **155° F**.

VPAK 24K BTUs Models:

2.5 KW, 230 V, Resistance 18.61 Ohms + - 5%.

Has 2 Limit Switches, Primary Opens at **155° F**, Closes at **125° F**, Secondary's Open Temp. is **200° F**.

3.4 KW, 230 V, Resistance 13.68 Ohms + - 5%.

Has 2 Limit Switches, Primary Opens at **155° F**, Closes at **125° F**, Secondary's Open Temp. is **200° F**.

5 KW, 230 V, Resistance 9.31 Ohms + - 5%.

Has 2 Limit Switches, Primary Opens at **155° F**, Closes at **125° F**, Secondary's Open Temp. is **200° F**.

7.5 KW, 230 V (composed of 2, 3.7 KW Elements)

Each Has a Resistance of **12.41 Ohms + - 5%**.
Each Has 2 Limit Switches, Primary Opens at **165° F**, Closes at **135° F** With a 1 time Open Temp. of **210° F**.
Secondary Limit's Open Temp. is **200° F**.

10 KW, 230 V (composed of 2, 5 KW Elements)

Each Has a Resistance of **9.31 Ohms + - 5%**.
Each Has 2 Limit Switches, Primary Opens at **165° F**, Closes at **135° F** With a 1 time Open Temp. of **210° F**.
Secondary Limit's Open Temp. is **200° F**.

NOTE: Always replace with an exact replacement.

TESTING THE HEATING ELEMENTS AND LIMIT SWITCHES

⚠ WARNING



ELECTRIC SHOCK HAZARD

Disconnect power to the unit before servicing. Failure to follow this warning could result in serious injury or death.

Testing of the heating elements can be made with an ohmmeter or continuity tester across the terminals after the power wires have been removed. Test the limit switch for continuity across its input and output terminals. Test below the limit switch's reset temperature.

DRAIN PAN VALVE

During the cooling mode of operation, condensate which collects in the drain pan is picked up by the condenser fan blade and sprayed onto the condenser coil. This assists in cooling the refrigerant plus evaporating the water.

During the heating mode of operation, it is necessary that water be removed to prevent it from freezing during cold outside temperatures. This could cause the condenser fan blade to freeze in the accumulated water and prevent it from turning.

To provide a means of draining this water, a bellows type drain valve is installed over a drain opening in the base pan.

This valve is temperature sensitive and will open when the outside temperature reaches 40°F. The valve will close gradually as the temperature rises above 40°F to fully close at 60°F.

Bellows Assembly
Drain Pan Valve



If outdoor temperature is at 40° F and drain valve does not open, replace it. (Ensure it is not restricted by debris).

External Static Pressure

External Static Pressure can best be defined as the pressure difference (drop) between the Positive Pressure (discharge) and the Negative Pressure (intake) sides of the blower. External Static Pressure is developed by the blower as a result of resistance to airflow (Friction) in the air distribution system EXTERNAL to the VERT-I-PAK cabinet.

Resistance applied externally to the VERT-I-PAK (i.e. duct work, filters, etc.) on either the supply or return side of the system causes an INCREASE in External Static Pressure accompanied by a REDUCTION in airflow.

External Static Pressure is affected by two (2) factors.

1. Resistance to Airflow as already explained.
2. Blower Speed. Changing to a higher or lower blower speed will raise or lower the External Static Pressure accordingly.

These affects must be understood and taken into consideration when checking External Static Pressure/Airflow to insure that the system is operating within design conditions.

Operating a system with insufficient or excessive airflow can cause a variety of different operating problems. Among these are reduced capacity, freezing evaporator coils, premature compressor and/or heating component failures. etc.

System airflow should always be verified upon completion of a new installation, or before a change-out, compressor replacement, or in the case of heat strip failure to insure that the failure was not caused by improper airflow.

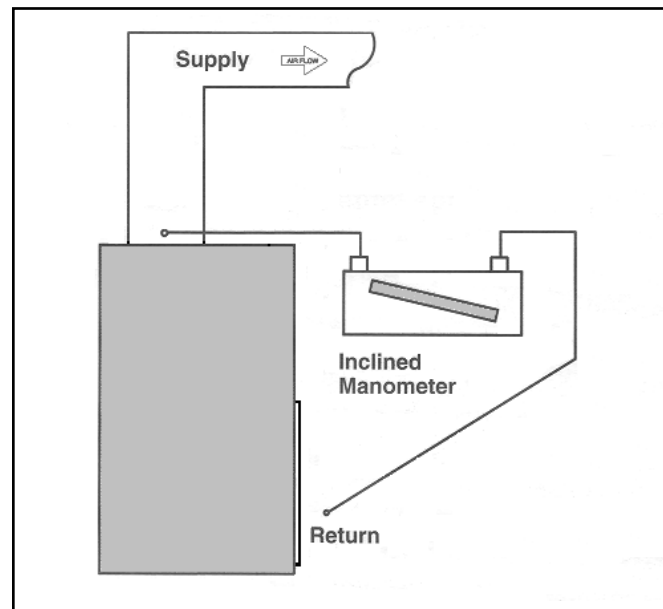

Checking External Static Pressure

The airflow through the unit can be determined by measuring the external static pressure of the system, and consulting the blower performance data for the specific VERT-I-PAK.

1. Set up to measure external static pressure at the supply and return air.
2. Ensure the coil and filter are clean, and that all the registers are open.
3. Determine the external static pressure with the blower operating.
4. Refer to the Air Flow Data for your VERT-I-PAK system to find the actual airflow for factory-selected fan speeds.
5. If the actual airflow is either too high or too low, the blower speed will need to be changed to appropriate setting or the ductwork will need to be reassessed and corrections made as required.
6. Select a speed, which most closely provides the required airflow for the system.
7. Recheck the external static pressure with the new speed. External static pressure (and actual airflow) will have changed to a higher or lower value depending upon speed selected. Recheck the actual airflow (at this "new" static pressure) to confirm speed selection.
8. Repeat steps 8 and 9 (if necessary) until proper airflow has been obtained.

EXAMPLE: Airflow requirements are calculated as follows: (Having a wet coil creates additional resistance to airflow. This additional resistance must be taken into consideration to obtain accurate airflow information.)

Determining the Indoor CFM: Chart A - CFM

ESP (")	Model					
	VEA09/VHA09		VEA12/VHA12		VEA18/VHA18	
	Low	High	Low	High	Low	High
.00"	340	385	420	470	430	480
.10"	300	340	350 *	420 **	400	450
.20"	230	280	290	350	340	400
.30"	140	190	250	300	290	330

Highlighted values indicate rated performance point.

Rated performance for

* VEA12

** Rated Performance for

VHA12

ESP (")	Model	
	VEA24/VHA24	
	Low	High
.00"	690	740
.10"	610	700
.20"	560	640
.30"	510	580
.40"	450	520

Highlighted values indicate rated performance point.

**Correct CFM (if needed):
Chart B – Correction Multipliers**

Correction Multipliers for:	
230V	1.00
208V	0.97
Heating	1.00
Cooling	0.95

Explanation of charts

Chart A is the nominal dry coil VERT-I-PAK CFMs. Chart B is the correction factors beyond nominal conditions.

1 ½ TON SYSTEM (18,000 Btu)

Operating on high speed @ 230 volts with dry coil

measured external static pressure .10

Air Flow = 450 CFM

In the same SYSTEM used in the previous example but having a WET coil you must use a correction factor of .95 (i.e. 450 x .95=428 CFM) to allow for the resistance (internal) of the condensate on the coil.

It is important to use the proper procedure to check external Static Pressure and determine actual airflow. Since in the case of the VERT-I-PAK, the condensate will cause a reduction in measured External Static Pressure for the given airflow.

It is also important to remember that when dealing with VERT-I-PAK units that the measured External Static Pressure increases as the resistance is added externally to the cabinet. Example: duct work, filters, grilles.

Indoor Airflow Data

The Vert-I-Pak A series units must be installed with a free return air configuration. The table below lists the indoor airflow at corresponding static pressures. All units are rated at low speed.

The Vert-I-Pak units are designed for either single speed or two fan speed operation. For single speed operation refer to the airflow table below and select the most appropriate CFM based on the ESP level. Connect the fan output from the thermostat to the unit on either the GL terminal for low speed or to the GH terminal for high speed operation.

For thermostats with two-speed fan outputs connect the low speed output to the unit GL terminal and the high speed output to the GH terminal.

Ductwork Preparation

If flex duct is used, be sure all the slack is pulled out of the flex duct. Flex duct ESP can increase considerably when not fully extended. DO NOT EXCEED a total of .30 ESP, as this is the MAXIMUM design limit for the VERT-I-PAK A-Series unit.

IMPORTANT: FLEX DUCT CAN COLLAPSE AND CAUSE AIRFLOW RESTRICTIONS. DO NOT USE FLEX DUCT FOR: 90 DEGREE BENDS, OR UNSUPPORTED RUNS OF 5 FT. OR MORE.

Fresh Air Door

The Fresh Air Door is an “intake” system. The fresh air door opened via a slide on the front of the chassis located just above the indoor coil. Move the slide left to open and right to close the fresh air door. The system is capable of up to 60 CFM of fresh air @ ~.3” H2O internal static pressure.

Checking Approximate Airflow

If an inclined manometer or Magnehelic gauge is not available to check the External Static Pressure, or the blower performance data is unavailable for your unit, approximate air flow call be calculated by measuring the temperature rise, then using the following criteria.

$$\frac{\text{KILOWATTS} \times 3413}{\text{Temp Rise} \times 1.08} = \text{CFM}$$

Electric Heat Strips

The approximate CFM actually being delivered can be calculated by using the following formula:

DO NOT simply use the Kilowatt Rating of the heater (i.e. 2.5, 3.4, 5.0) as this will result in a less-than-correct airflow calculation. Kilowatts may be calculated by multiplying the measured voltage to the unit (heater) times the measured current draw of all heaters (ONLY) in operation to obtain watts. Kilowatts are then obtained by dividing by 1000.

EXAMPLE: Measured voltage to unit (heaters) is 230 volts. Measured Current Draw of strip heaters is 11.0 amps.

$$\begin{aligned} 230 \times 11.0 &= 2530 \\ 2530/1000 &= 2.53 \text{ Kilowatts} \\ 2.53 \times 3413 &= 8635 \end{aligned}$$

Supply Air	95°F
Return Air	- 75°F
Temperature Rise	<u>20°</u>

$$20 \times 1.08 = 21.6$$

$$\frac{8635}{21.6} = 400 \text{ CFM}$$

REFRIGERATION SEQUENCE OF OPERATION

A good understanding of the basic operation of the refrigeration system is essential for the service technician. Without this understanding, accurate troubleshooting of refrigeration system problems will be more difficult and time consuming, if not (in some cases) entirely impossible. The refrigeration system uses four basic principles (laws) in its operation they are as follows:

1. "Heat always flows from a warmer body to a cooler body."
2. "Heat must be added to or removed from a substance before a change in state can occur"
3. "Flow is always from a higher pressure area to a lower pressure area."
4. "The temperature at which a liquid or gas changes state is dependent upon the pressure."

The refrigeration cycle begins at the compressor. Starting the compressor creates a low pressure in the suction line which draws refrigerant gas (vapor) into the compressor. The compressor then "compresses" this refrigerant, raising its pressure and its (heat intensity) temperature.

The refrigerant leaves the compressor through the discharge Line as a hot High pressure gas (vapor). The refrigerant enters the condenser coil where it gives up some of its heat. The condenser fan moving air across the coil's finned surface facilitates the transfer of heat from the refrigerant to the relatively cooler outdoor air.

When a sufficient quantity of heat has been removed from the refrigerant gas (vapor), the refrigerant will "condense" (i.e. change to a liquid). Once the refrigerant has been condensed (changed) to a liquid it is cooled even further by the air that continues to flow across the condenser coil.

The VPAK design determines at exactly what point (in the condenser) the change of state (i.e. gas to a liquid) takes place. In all cases, however, the refrigerant must be totally condensed (changed) to a Liquid before leaving the condenser coil.

The refrigerant leaves the condenser Coil through the liquid line as a warm high pressure liquid. It next will pass through the refrigerant drier (if so equipped). It is the function of the drier to trap any moisture present in the system, contaminants, and large particulate matter.

The liquid refrigerant next enters the metering device. The metering device is a capillary tube. The purpose of the metering device is to "meter" (i.e. control or measure) the quantity of refrigerant entering the evaporator coil.

In the case of the capillary tube this is accomplished (by design) through size (and length) of device, and the pressure difference present across the device.

Since the evaporator coil is under a lower pressure (due to the suction created by the compressor) than the liquid line, the liquid refrigerant leaves the metering device entering the evaporator coil. As it enters the evaporator coil, the larger area and lower pressure allows the refrigerant to expand and lower its temperature (heat intensity). This expansion is often referred to as "boiling". Since the unit's blower is moving indoor air across the finned surface of the evaporator coil, the expanding refrigerant absorbs some of that heat. This results in a lowering of the indoor air temperature, hence the "cooling" effect.

The expansion and absorbing of heat cause the liquid refrigerant to evaporate (i.e. change to a gas). Once the refrigerant has been evaporated (changed to a gas), it is heated even further by the air that continues to flow across the evaporator coil.

The particular system design determines at exactly what point (in the evaporator) the change of state (i.e. liquid to a gas) takes place. In all cases, however, the refrigerant must be totally evaporated (changed) to a gas before leaving the evaporator coil.

The low pressure (suction) created by the compressor causes the refrigerant to leave the evaporator through the suction line as a cool low pressure vapor. The refrigerant then returns to the compressor, where the cycle is repeated.

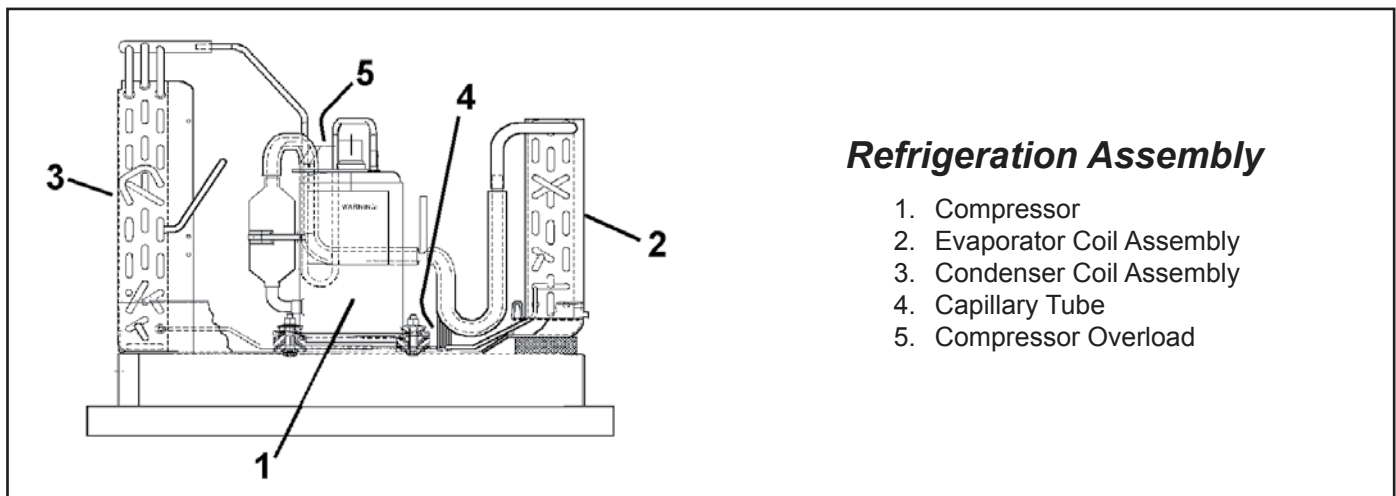

Refrigeration Assembly

1. Compressor
2. Evaporator Coil Assembly
3. Condenser Coil Assembly
4. Capillary Tube
5. Compressor Overload

SEALED REFRIGERATION SYSTEM REPAIRS

IMPORTANT

ANY SEALED SYSTEM REPAIRS TO COOL-ONLY MODELS REQUIRE THE INSTALLATION OF A LIQUID LINE DRIER. ALSO, ANY SEALED SYSTEM REPAIRS TO HEAT PUMP MODELS REQUIRE THE INSTALLATION OF A SUCTION LINE DRIER.

EQUIPMENT REQUIRED:

1. Voltmeter
2. Ammeter
3. Ohmmeter
4. E.P.A. Approved Refrigerant Recovery System
5. Vacuum Pump (capable of 200 microns or less vacuum.)
6. Acetylene Welder
7. Electronic Halogen Leak Detector capable of detecting HFC (Hydrofluorocarbon) refrigerants.
8. Accurate refrigerant charge measuring device such as:
 - a. Balance Scales - 1/2 oz. accuracy
 - b. Charging Board - 1/2 oz. accuracy
9. High Pressure Gauge - (0 - 750 lbs.)
10. Low Pressure Gauge - (30 - 200 lbs.)
11. Vacuum Gauge - (0 - 1000 microns)
12. Facilities for flowing nitrogen through refrigeration tubing during all brazing processes.

EQUIPMENT MUST BE CAPABLE OF:

1. Recovering refrigerant to EPA required levels.
2. Evacuation from both the high side and low side of the system simultaneously.
3. Introducing refrigerant charge into high side of the system.
4. Accurately weighing the refrigerant charge actually introduced into the system.

⚠ WARNING



RISK OF ELECTRIC SHOCK

Unplug and/or disconnect all electrical power to the unit before performing inspections, maintenances or service.

Failure to do so could result in electric shock, serious injury or death.

⚠ WARNING



HIGH PRESSURE HAZARD

Sealed Refrigeration System contains refrigerant and oil under high pressure.

Proper safety procedures must be followed, and proper protective clothing must be worn when working with refrigerants.

Failure to follow these procedures could result in serious injury or death.

Too much refrigerant (overcharge) in the system is just as bad (if not worse) than not enough refrigerant (undercharge). They both can be the source of certain compressor failures if they remain uncorrected for any period of time. Quite often, other problems (such as low air flow across evaporator, etc.) are misdiagnosed as refrigerant charge problems. The refrigerant circuit diagnosis chart will assist you in properly diagnosing these systems.

An overcharged unit will at times return liquid refrigerant (slugging) back to the suction side of the compressor eventually causing a mechanical failure within the compressor. This mechanical failure can manifest itself as valve failure, bearing failure, and/or other mechanical failure. The specific type of failure will be influenced by the amount of liquid being returned, and the length of time the slugging continues.

Not enough refrigerant (undercharge) on the other hand, will cause the temperature of the suction gas to increase to the point where it does not provide sufficient cooling for the compressor motor. When this occurs, the motor winding temperature will increase causing the motor to overheat and possibly cycle open the compressor overload protector. Continued overheating of the motor windings and/or cycling of the overload will eventually lead to compressor motor or overload failure.

Refrigerant Charging

Proper refrigerant charge is essential to proper unit operation. Operating a unit with an improper refrigerant charge will result in reduced performance (capacity) and/or efficiency. Accordingly, the use of proper charging methods during servicing will insure that the unit is functioning as designed and that its compressor will not be damaged.

Method Of Charging / Repairs

The acceptable method for charging the RAC system is the Weighed in Charge Method. The weighed in charge method is applicable to all units. It is the preferred method to use, as it is the most accurate.

The weighed in method should always be used whenever a charge is removed from a unit such as for a leak repair, compressor replacement, or when there is no refrigerant charge left in the unit. To charge by this method, requires the following steps:

1. Install a piercing valve to remove refrigerant from the sealed system. (Piercing valve must be removed from the system before recharging.)
2. Recover Refrigerant in accordance with EPA regulations.

⚠ WARNING	
	<p>BURN HAZARD Proper safety procedures must be followed, and proper protective clothing must be worn when working with a torch.</p> <p>Failure to follow these procedures could result in moderate or serious injury.</p>

3. Install a process tube to sealed system.

⚠ CAUTION	
	<p>FREEZE HAZARD Proper safety procedures must be followed, and proper protective clothing must be worn when working with liquid refrigerant.</p> <p>Failure to follow these procedures could result in minor to moderate injury.</p>

4. Make necessary repairs to system.
5. Evacuate system to 200 microns or less.
6. Weigh in refrigerant with the property quantity of R-410A refrigerant.
7. Start unit, and verify performance.

⚠ WARNING	
	<p>BURN HAZARD Proper safety procedures must be followed, and proper protective clothing must be worn when working with a torch.</p> <p>Failure to follow these procedures could result in moderate or serious injury.</p>

8. Crimp the process tube and solder the end shut.

⚠ WARNING	
	<p>ELECTRIC SHOCK HAZARD Turn off electric power before service or installation.</p> <p>Extreme care must be used, if it becomes necessary to work on equipment with power applied.</p> <p>Failure to do so could result in serious injury or death.</p>

⚠ WARNING	
	<p>HIGH PRESSURE HAZARD Sealed Refrigeration System contains refrigerant and oil under high pressure.</p> <p>Proper safety procedures must be followed, and proper protective clothing must be worn when working with refrigerants.</p> <p>Failure to follow these procedures could result in serious injury or death.</p>

Undercharged Refrigerant Systems

An undercharged system will result in poor performance (low pressures, etc.) in both the heating and cooling cycle.

Whenever you service a unit with an undercharge of refrigerant, always suspect a leak. The leak must be repaired before charging the unit.

To check for an undercharged system, turn the unit on, allow the compressor to run long enough to establish working pressures in the system (15 to 20 minutes).

During the cooling cycle you can listen carefully at the exit of the metering device into the evaporator; an intermittent hissing and gurgling sound indicates a low refrigerant charge. Intermittent frosting and thawing of the evaporator is another indication of a low charge, however, frosting and thawing can also be caused by insufficient air over the evaporator.

Checks for an undercharged system can be made at the compressor. If the compressor seems quieter than normal, it is an indication of a low refrigerant charge.

A check of the amperage drawn by the compressor motor should show a lower reading. (Check the Unit Specification.)

After the unit has run 10 to 15 minutes, check the gauge pressures. Gauges connected to system with an undercharge will have low head pressures and substantially low suction pressures.



Overcharged Refrigerant Systems

Compressor amps will be near normal or higher. Noncondensables can also cause these symptoms. To confirm, remove some of the charge, if conditions improve, system may be overcharged. If conditions don't improve, Noncondensables are indicated.

Whenever an overcharged system is indicated, always make sure that the problem is not caused by air flow problems.

Improper air flow over the evaporator coil may indicate some of the same symptoms as an overcharged system. An overcharge can cause the compressor to fail, since it would be "slugged" with liquid refrigerant.

The charge for any system is critical. When the compressor is noisy, suspect an overcharge, when you are sure that the air quantity over the evaporator coil is correct. Icing of the evaporator will not be encountered because the refrigerant will boil later if at all. Gauges connected to system will usually have higher head pressure (depending upon amount of overcharge). Suction pressure should be slightly higher.

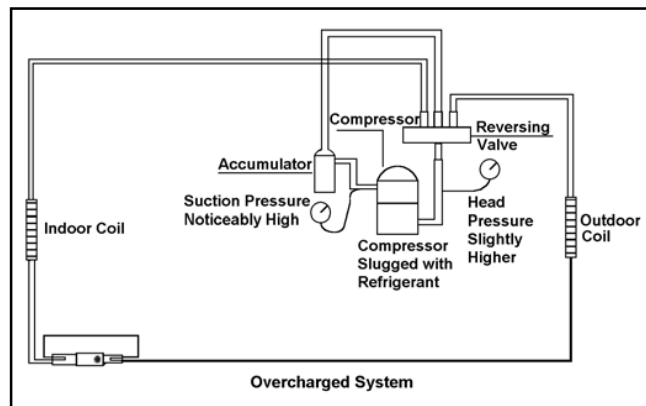

Restricted Refrigerant System

Troubleshooting a restricted refrigerant system can be difficult. The following procedures are the more common problems and solutions to these problems. There are two types of refrigerant restrictions: Partial restrictions and complete restrictions.

A partial restriction allows some of the refrigerant to circulate through the system.

With a complete restriction there is no circulation of refrigerant in the system.

Restricted refrigerant systems display the same symptoms as a "low-charge condition."

When the unit is shut off, the gauges may equalize very slowly.

Gauges connected to a completely restricted system will run in a deep vacuum. When the unit is shut off, the gauges will not equalize at all.

A quick check for either condition begins at the evaporator. With a partial restriction, there may be gurgling sounds at the metering device entrance to the evaporator. The evaporator in a partial restriction could be partially frosted or have an ice ball close to the entrance of the metering device. Frost may continue on the suction line back to the compressor.

Often a partial restriction of any type can be found by feel, as there is a temperature difference from one side of the restriction to the other.

With a complete restriction, there will be no sound at the metering device entrance. An amperage check of the compressor with a partial restriction may show normal current when compared to the unit specification.

With a complete restriction the current drawn may be considerably less than normal, as the compressor is running in a deep vacuum (no load.) Much of the area of the condenser will be relatively cool since most or all of the liquid refrigerant will be stored there.

The following conditions are based primarily on a system in the cooling mode.

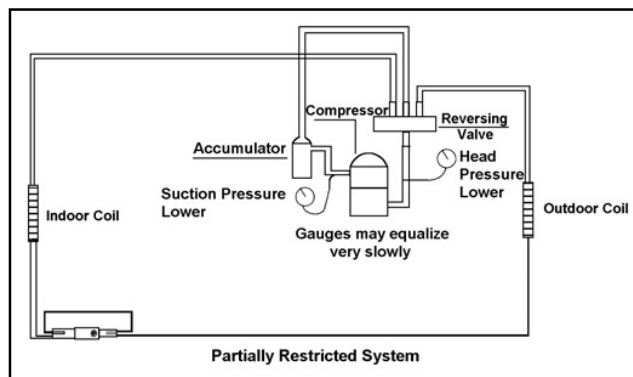
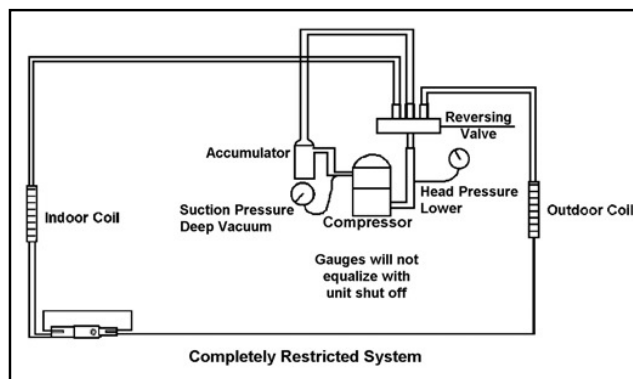

HERMETIC COMPONENTS CHECK

⚠ WARNING



BURN HAZARD

Proper safety procedures must be followed, and proper protective clothing must be worn when working with a torch.

Failure to follow these procedures could result in moderate or serious injury.

⚠ WARNING



CUT/SEVER HAZARD

Be careful with the sharp edges and corners. Wear protective clothing and gloves, etc.

Failure to do so could result in serious injury.

METERING DEVICE

Capillary Tube Systems

All units are equipped with capillary tube metering devices.

Checking for restricted capillary tubes.

1. Connect pressure gauges to unit.
2. Start the unit in the cooling mode. If after a few minutes of operation the pressures are normal, the check valve and the cooling capillary are not restricted.

3. Switch the unit to the heating mode and observe the gauge readings after a few minutes running time. If the system pressure is lower than normal, the heating capillary is restricted.
4. If the operating pressures are lower than normal in both the heating and cooling mode, the cooling capillary is restricted.

CHECK VALVE

A unique two-way check valve is used on the reverse cycle heat pumps. It is pressure operated and used to direct the flow of refrigerant through a single filter drier and to the proper capillary tube during either the heating or cooling cycle.

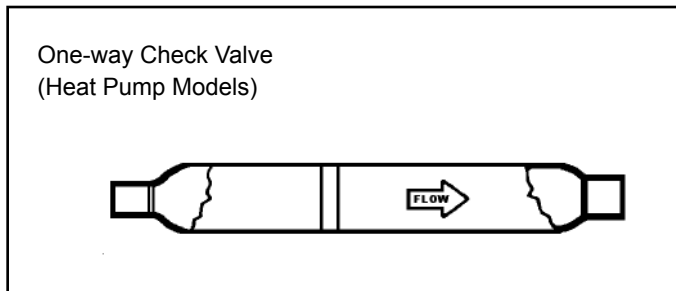

NOTE: The slide (check) inside the valve is made of teflon. Should it become necessary to replace the check valve, place a wet cloth around the valve to prevent overheating during the brazing operation.

CHECK VALVE OPERATION

In the cooling mode of operation, high pressure liquid enters the check valve forcing the slide to close the opposite port (liquid line) to the indoor coil. Refer to refrigerant flow chart. This directs the refrigerant through the filter drier and cooling capillary tube to the indoor coil.

In the heating mode of operation, high pressure refrigerant enters the check valve from the opposite direction, closing

the port (liquid line) to the outdoor coil. The flow path of the refrigerant is then through the filter drier and heating capillary to the outdoor coil.

Failure of the slide in the check valve to seat properly in either mode of operation will cause flooding of the cooling coil. This is due to the refrigerant bypassing the heating or cooling capillary tube and entering the liquid line.

COOLING MODE

In the cooling mode of operation, liquid refrigerant from condenser (liquid line) enters the cooling check valve forcing the heating check valve shut. The liquid refrigerant is directed into the liquid dryer after which the refrigerant is metered through cooling capillary tubes to evaporator. (Note: liquid refrigerant will also be directed through the heating capillary tubes in a continuous loop during the cooling mode).

HEATING MODE

In the heating mode of operation, liquid refrigerant from the indoor coil enters the heating check valve forcing the cooling check valve shut. The liquid refrigerant is directed into the liquid dryer after which the refrigerant is metered through the heating capillary tubes to outdoor coils. (Note: liquid refrigerant will also be directed through the cooling capillary tubes in a continuous loop during the heating mode).

REVERSING VALVE DESCRIPTION/OPERATION

⚠ WARNING



ELECTRIC SHOCK HAZARD

Disconnect power to the unit before servicing. Failure to follow this warning could result in serious injury or death.

The Reversing Valve controls the direction of refrigerant flow to the indoor and outdoor coils. It consists of a pressure-operated, main valve and a pilot valve actuated by a solenoid plunger. The solenoid is energized during the heating cycle only. The reversing valves used in the PTAC system is a 2-position, 4-way valve.

The single tube on one side of the main valve body is the high-pressure inlet to the valve from the compressor. The center tube on the opposite side is connected to the low pressure (suction) side of the system. The other two are connected to the indoor and outdoor coils. Small capillary tubes connect each end of the main valve cylinder to the “A” and “B” ports of the pilot valve. A third capillary is a common return line from these ports to the suction tube on the main valve body. Four-way reversing valves also have a capillary tube from the compressor discharge tube to the pilot valve.

The piston assembly in the main valve can only be shifted by the pressure differential between the high and low sides

of the system. The pilot section of the valve opens and closes ports for the small capillary tubes to the main valve to cause it to shift.

NOTE: System operating pressures must be near normal before valve can shift.

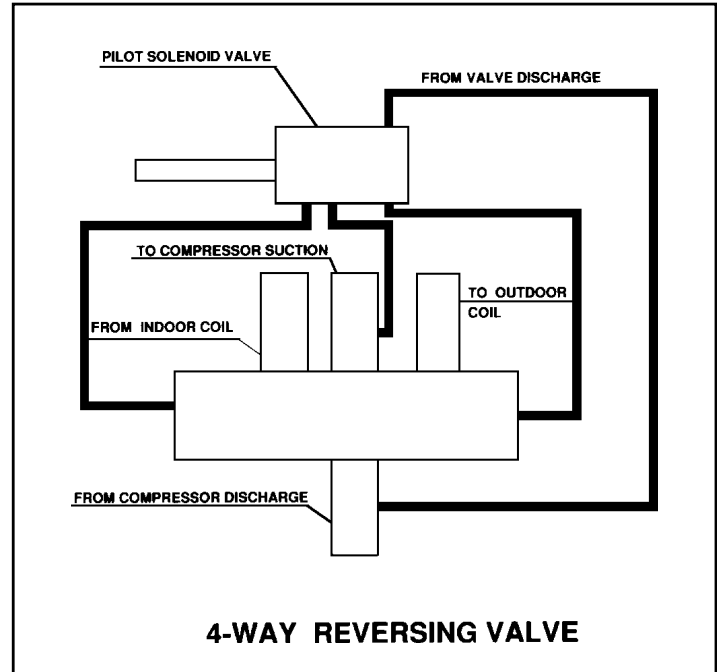

4-WAY REVERSING VALVE

TESTING THE COIL

⚠ WARNING



ELECTRIC SHOCK HAZARD

Unplug and/or disconnect all electrical power to the unit before performing inspections, maintenances or service.

Failure to do so could result in electric shock, serious injury or death.

The solenoid coil is an electromagnetic type coil mounted on the reversing valve and is energized during the operation of the compressor in the heating cycle.

1. Turn off high voltage electrical power to unit.
2. Unplug line voltage lead from reversing valve coil.
3. Check for electrical continuity through the coil. If you do not have continuity replace the coil.
4. Check from each lead of coil to the copper liquid line as it leaves the unit or the ground lug. There should be no continuity between either of the coil leads and ground; if there is, coil is grounded and must be replaced.
5. If coil tests okay, reconnect the electrical leads.
6. Make sure coil has been assembled correctly.

NOTE: Do not start unit with solenoid coil removed from valve, or do not remove coil after unit is in operation. This will cause the coil to burn out.

CHECKING THE REVERSING VALVE

NOTE: You must have normal operating pressures before the reversing valve can shift.

⚠ WARNING

HIGH PRESSURE HAZARD

Sealed Refrigeration System contains refrigerant and oil under high pressure.

Proper safety procedures must be followed, and proper protective clothing must be worn when working with refrigerants.

Failure to follow these procedures could result in serious injury or death.



Check the operation of the valve by starting the system and switching the operation from “Cooling” to “Heating” and then back to “Cooling”. Do not hammer on valve.

Occasionally, the reversing valve may stick in the heating or cooling position or in the mid-position.

When sluggish or stuck in the mid-position, part of the discharge gas from the compressor is directed back to the suction side, resulting in excessively high suction pressure.

Should the valve fail to shift from cooling to heating, block the air flow through the outdoor coil and allow the discharge pressure to build in the system. Then switch the system from heating to cooling.

If the valve is stuck in the heating position, block the air flow through the indoor coil and allow discharge pressure to build in the system. Then switch the system from heating to cooling.

Should the valve fail to shift in either position after increasing the discharge pressure, replace the valve.

Dented or damaged valve body or capillary tubes can prevent the main slide in the valve body from shifting.

If you determine this is the problem, replace the reversing valve.

After all of the previous inspections and checks have been made and determined correct, then perform the "Touch Test" on the reversing valve.

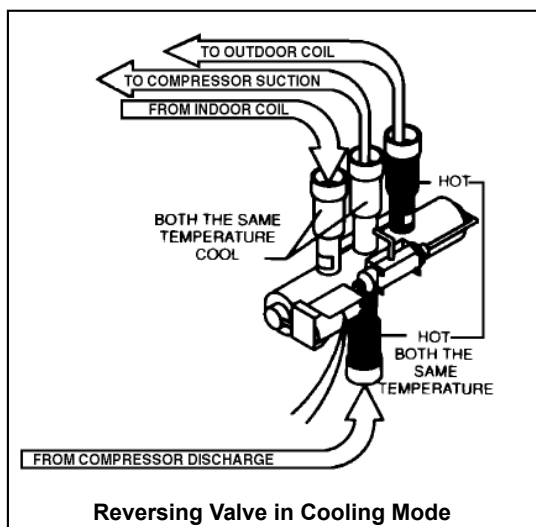
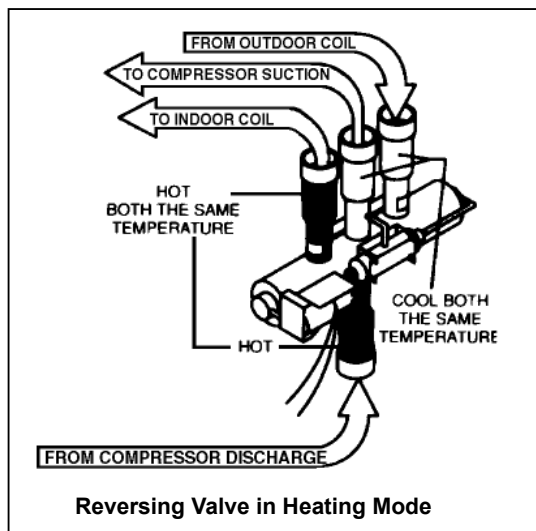

Touch Test in Heating/Cooling Cycle

⚠ WARNING	
	<p>BURN HAZARD</p> <p>Certain unit components operate at temperatures hot enough to cause burns.</p> <p>Proper safety procedures must be followed, and proper protective clothing must be worn.</p> <p>Failure to follow these procedures could result in minor to moderate injury.</p>

The only definite indications that the slide is in the mid-position is if all three tubes on the suction side of the valve are hot after a few minutes of running time.

NOTE: A condition other than those illustrated above, and on Page 31, indicate that the reversing valve is not shifting properly. Both tubes shown as hot or cool must be the same corresponding temperature.

Procedure For Changing Reversing Valve

⚠ WARNING	
	<p>HIGH PRESSURE HAZARD</p> <p>Sealed Refrigeration System contains refrigerant and oil under high pressure.</p> <p>Proper safety procedures must be followed, and proper protective clothing must be worn when working with refrigerants.</p> <p>Failure to follow these procedures could result in serious injury or death.</p>

NOTICE	
<p>FIRE HAZARD</p> <p>The use of a torch requires extreme care and proper judgment. Follow all safety recommended precautions and protect surrounding areas with fire proof materials. Have a fire extinguisher readily available. Failure to follow this notice could result in moderate to serious property damage.</p>	

1. Install Process Tubes. Recover refrigerant from sealed system. PROPER HANDLING OF RECOVERED REFRIGERANT ACCORDING TO EPA REGULATIONS IS REQUIRED.
2. Remove solenoid coil from reversing valve. If coil is to be reused, protect from heat while changing valve.
3. Unbraid all lines from reversing valve.
4. Clean all excess braze from all tubing so that they will slip into fittings on new valve.
5. Remove solenoid coil from new valve.

6. Protect new valve body from heat while brazing with plastic heat sink (Thermo Trap) or wrap valve body with wet rag.
7. Fit all lines into new valve and braze lines into new valve.

⚠ WARNING	
	EXPLOSION HAZARD The use of nitrogen requires a pressure regulator. Follow all safety procedures and wear protective safety clothing etc.
	Failure to follow proper safety procedures could result in serious injury or death.

8. Pressurize sealed system with a combination of R-410A and nitrogen and check for leaks, using a suitable leak detector. Recover refrigerant per EPA guidelines.
9. Once the sealed system is leak free, install solenoid coil on new valve and charge the sealed system by weighing in the proper amount and type of refrigerant as shown on rating plate. Crimp the process tubes and solder the ends shut. Do not leave Schrader or piercing valves in the sealed system.

NOTE: When brazing a reversing valve into the system, it is of extreme importance that the temperature of the valve does not exceed 250°F at any time.

Wrap the reversing valve with a large rag saturated with water. “Re-wet” the rag and thoroughly cool the valve after each brazing operation of the four joints involved.

The wet rag around the reversing valve will eliminate conduction of heat to the valve body when brazing the line connection.

COMPRESSOR CHECKS

⚠ WARNING	
	ELECTRIC SHOCK HAZARD Turn off electric power before service or installation. Extreme care must be used, if it becomes necessary to work on equipment with power applied.
	Failure to do so could result in serious injury or death.

Locked Rotor Voltage (L.R.V.) Test

Locked rotor voltage (L.R.V.) is the actual voltage available at the compressor under a stalled condition.

Single Phase Connections

Disconnect power from unit. Using a voltmeter, attach one lead of the meter to the run “R” terminal on the compressor and the other lead to the common “C” terminal of the compressor. Restore power to unit.

Determine L.R.V.

Start the compressor with the volt meter attached; then stop the unit. Attempt to restart the compressor within a couple of seconds and immediately read the voltage on the meter. The compressor under these conditions will not start and will usually kick out on overload within a few seconds since the pressures in the system will not have had time to equalize. Voltage should be at or above minimum voltage of 197 VAC, as specified on the rating plate. If less than minimum, check for cause of inadequate power supply; i.e., incorrect wire size, loose electrical connections, etc.

Amperage (L.R.A.) Test

The running amperage of the compressor is the most important of these readings. A running amperage higher than that indicated in the performance data indicates that a problem exists mechanically or electrically.

Single Phase Running and L.R.A. Test

NOTE: Consult the specification and performance section for running amperage. The L.R.A. can also be found on the rating plate.

Select the proper amperage scale and clamp the meter probe around the wire to the “C” terminal of the compressor.

Turn on the unit and read the running amperage on the meter. If the compressor does not start, the reading will indicate the locked rotor amperage (L.R.A.).

Overloads

The compressor is equipped with an external or internal overload which senses both motor amperage and winding temperature. High motor temperature or amperage heats the overload causing it to open, breaking the common circuit within the compressor.

Heat generated within the compressor shell, usually due to recycling of the motor, is slow to dissipate. It may take anywhere from a few minutes to several hours for the overload to reset.

Checking the Overload

⚠ WARNING	
	ELECTRIC SHOCK HAZARD Turn off electric power before service or installation. Extreme care must be used, if it becomes necessary to work on equipment with power applied.
	Failure to do so could result in serious injury or death.

⚠ WARNING



BURN HAZARD

Certain unit components operate at temperatures hot enough to cause burns.

Proper safety procedures must be followed, and proper protective clothing must be worn.

Failure to follow this warning could result in moderate to serious injury.

External Overload VPAK 9, 12, 18 K Btus

With power off, remove the leads from compressor terminals. If the compressor is hot, allow the overload to cool before starting check. Using an ohmmeter, test continuity across the terminals of the external overload. If you do not have continuity; this indicates that the overload is open and must be replaced.

Internal Overload VPAK 24 K Btus

The overload is embedded in the motor windings to sense the winding temperature and/or current draw. The overload is connected in series with the common motor terminal.

1. With no power to unit, remove the leads from the compressor terminals. Allow motor to cool.
2. Using an ohmmeter, test continuity between terminals C-S and C-R. If no continuity, the compressor overload is open and the compressor must be replaced.

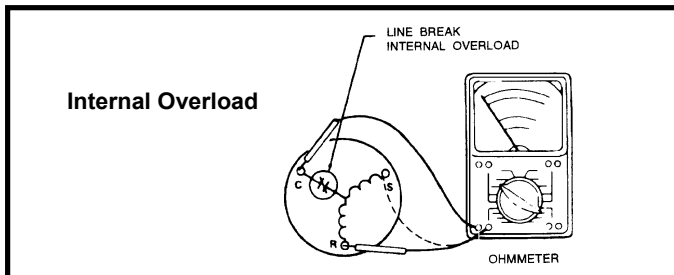

Single Phase Resistance Test

⚠ WARNING



ELECTRIC SHOCK HAZARD

Turn off electric power before service or installation. Extreme care must be used, if it becomes necessary to work on equipment with power applied.

Failure to do so could result in serious injury or death.

Remove the leads from the compressor terminals and set the ohmmeter on the lowest scale (R x 1).

Touch the leads of the ohmmeter from terminals common to start (“C” to “S”). Next, touch the leads of the ohmmeter from terminals common to run (“C” to “R”).

Add values “C” to “S” and “C” to “R” together and check resistance from start to run terminals (“S” to “R”). Resistance “S” to “R” should equal the total of “C” to “S” and “C” to “R.”

In a single phase PSC compressor motor, the highest value will be from the start to the run connections (“S” to “R”). The next highest resistance is from the start to the common connections (“S” to “C”). The lowest resistance is from the run to common. (“C” to “R”) Before replacing a compressor, check to be sure it is defective.

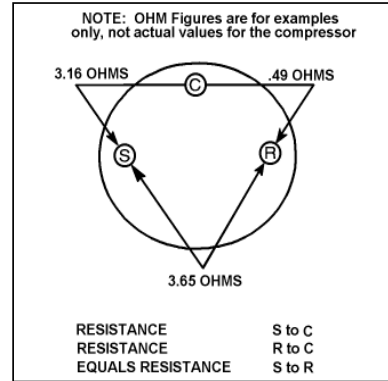

GROUND TEST

Use an ohmmeter set on its highest scale. Touch one lead to the compressor body (clean point of contact as a good connection is a must) and the other probe in turn to each compressor terminal. If a reading is obtained the compressor is grounded and must be replaced.

Check the complete electrical system to the compressor and compressor internal electrical system, check to be certain that compressor is not out on internal overload.

Complete evaluation of the system must be made whenever you suspect the compressor is defective. If the compressor has been operating for sometime, a careful examination must be made to determine why the compressor failed.

Many compressor failures are caused by the following conditions:

1. Improper air flow over the evaporator.
2. Overcharged refrigerant system causing liquid to be returned to the compressor.
3. Restricted refrigerant system.
4. Lack of lubrication.
5. Liquid refrigerant returning to compressor causing oil to be washed out of bearings.
6. Noncondensables such as air and moisture in the system. Moisture is extremely destructive to a refrigerant system.

COMPRESSOR REPLACEMENT

Recommended procedure for compressor replacement

⚠ WARNING	
	<p>RISK OF ELECTRIC SHOCK Unplug and/or disconnect all electrical power to the unit before performing inspections, maintenances or service.</p> <p>Failure to do so could result in electric shock, serious injury or death.</p>

1. Be certain to perform all necessary electrical and refrigeration tests to be sure the compressor is actually defective before replacing.

⚠ WARNING	
	<p>HIGH PRESSURE HAZARD Sealed Refrigeration System contains refrigerant and oil under high pressure.</p> <p>Proper safety procedures must be followed, and proper protective clothing must be worn when working with refrigerants.</p> <p>Failure to follow these procedures could result in serious injury or death.</p>

2. Recover all refrigerant from the system though the process tubes. **PROPER HANDLING OF RECOVERED REFRIGERANT ACCORDING TO EPA REGULATIONS IS REQUIRED.** Do not use gauge manifold for this purpose if there has been a burnout. You will contaminate your manifold and hoses. Use a Schrader valve adapter and copper tubing for burnout failures.

⚠ WARNING	
	<p>HIGH TEMPERATURES Extreme care, proper judgment and all safety procedures must be followed when testing, troubleshooting, handling or working around unit while in operation with high temperature components. Wear protective safety aids such as: gloves, clothing etc.</p> <p>Failure to do so could result in serious burn injury.</p>

NOTICE	
FIRE HAZARD	
<p>The use of a torch requires extreme care and proper judgment. Follow all safety recommended precautions and protect surrounding areas with fire proof materials. Have a fire extinguisher readily available. Failure to follow this notice could result in moderate to serious property damage.</p>	

3. After all refrigerant has been recovered, disconnect suction and discharge lines from the compressor and remove compressor. Be certain to have both suction and discharge process tubes open to atmosphere.
4. Carefully pour a small amount of oil from the suction stub of the defective compressor into a clean container.
5. Using an acid test kit (one shot or conventional kit), test the oil for acid content according to the instructions with the kit.
6. If any evidence of a burnout is found, no matter how slight, the system will need to be cleaned up following proper procedures.
7. Install the replacement compressor.

⚠ WARNING	
	<p>EXPLOSION HAZARD The use of nitrogen requires a pressure regulator. Follow all safety procedures and wear protective safety clothing etc.</p> <p>Failure to follow proper safety procedures result in serious injury or death.</p>

8. Pressurize with a combination of R-410A and nitrogen and leak test all connections with leak detector capable of detecting HFC (Hydrofluorocarbon) refrigerant. Recover refrigerant/nitrogen mixture and repair any leaks found.

Repeat Step 8 to insure no more leaks are present.

9. Evacuate the system with a good vacuum pump capable of a final vacuum of 200 microns or less. The system should be evacuated through both liquid line and suction line gauge ports. While the unit is being evacuated, seal all openings on the defective compressor.

⚠ CAUTION	
	<p>FREEZE HAZARD Proper safety procedures must be followed, and proper protective clothing must be worn when working with liquid refrigerant.</p> <p>Failure to follow these procedures could result in minor to moderate injury.</p>

10. Recharge the system with the correct amount of refrigerant. The proper refrigerant charge will be found on the unit rating plate. The use of an accurate measuring device, such as a charging cylinder, electronic scales or similar device is necessary.

NOTE: NEVER, under any circumstances, liquid charge a rotary compressor through the **LOW** side. Doing so would cause permanent damage to the new compressor.

SPECIAL PROCEDURE IN THE CASE OF MOTOR COMPRESSOR BURNOUT

⚠ WARNING	
	<p>ELECTRIC SHOCK HAZARD Turn off electric power before service or installation.</p> <p>Failure to do so may result in personal injury, or death.</p>

⚠ WARNING	
	<p>HIGH PRESSURE HAZARD Sealed Refrigeration System contains refrigerant and oil under high pressure.</p> <p>Proper safety procedures must be followed, and proper protective clothing must be worn when working with refrigerants.</p> <p>Failure to follow these procedures could result in serious injury or death.</p>

⚠ WARNING	
	<p>EXPLOSION HAZARD The use of nitrogen requires a pressure regulator. Follow all safety procedures and wear protective safety clothing etc.</p> <p>Failure to follow proper safety procedures result in serious injury or death.</p>

1. Recover all refrigerant and oil from the system.
2. Remove compressor, capillary tube and filter drier from the system.
3. Flush evaporator condenser and all connecting tubing with dry nitrogen or equivalent. Use approved flushing agent to remove all contamination from system. Inspect suction and discharge line for carbon deposits. Remove and clean if necessary. Ensure all acid is neutralized.
4. Reassemble the system, including new drier strainer and capillary tube.
5. Proceed with step 8-10 on previous page.

ROUTINE MAINTENANCE

⚠ WARNING	
	<p>ELECTRICAL SHOCK HAZARD! Turn off electrical power before service or installation. All electrical connections and wiring MUST be installed by a qualified electrician and conform to the National Code and all local codes which have jurisdiction. Failure to do so can result in property damage, personal injury and/or death.</p>

To ensure proper unit operation and life expectancy, the following maintenance procedures should be performed on a regular basis

1. Air Filter

To ensure proper unit operation, the air filters should be replaced at least monthly, and more frequently if conditions warrant.

2. Coils & Chassis

NOTE: Do not use a caustic coil cleaning agent on coils or base pan. Use a biodegradable cleaning agent and degreaser. The use of harsh cleaning materials may lead to deterioration of the aluminum fins or the coil end plates.

The indoor coil and outdoor coils and base pan should be inspected periodically (annually or semi-annually) and cleaned of all debris (lint, dirt, leaves, paper, etc.) as necessary. Under extreme conditions, more frequent cleaning may be required. Clean the coils and base pan with a soft brush and compressed air or vacuum. A pressure washer may also be used, however, you must be careful not to bend the aluminum fin pack. Use a sweeping up and down motion in the direction of the vertical aluminum fin pack when pressure cleaning coils.

Note: It is extremely important to insure that none of the electrical and/or electronic parts of the unit get wet. Be sure to cover all electrical components to protect them from water or spray.

3. Fresh Air Vent

Ensure the fresh air vent door and lever are operating properly.

4. Fan Motor & Compressor

The fan motor & compressor are permanently lubricated, and require no additional lubrication.

5. Drain System

Inspect the drain system periodically (annually or semi-annually) and clean as required. Under extreme conditions, more frequent cleaning may be necessary. Clean these areas with an antibacterial and antifungal cleaner. Rinse both items thoroughly with water and ensure that the drain outlets are operating properly.



FRIEDRICH

ROOM AIR CONDITIONER UNIT PERFORMANCE TEST DATA SHEET

JOB NAME _____ TECHS NAME _____

DATE: _____ MODEL: _____ SERIAL: _____

HOW IS ALL OF THE INSTALLATION?	GOOD YES	BAD NO
IS THE UNIT INSTALLED 2 3/8" INTO THE PLENUM?	_____	_____
IS THE FRESH/EXHAUST AIR VENT OPEN?	_____	_____
IS A FRIEDRICH 'H' WALL PLENUM INSTALLED?	_____	_____
IS A FRIEDRICH OUTDOOR GRILLE INSTALLED?	_____	_____
IS MAINTENANCE BEING PERFORMED?	_____	_____

If **NO** is checked use back of sheet for explanation

ELECTRICAL:

LINE VOLTAGE (STATIC) ----- VOLTS

START UP VOLTAGE ----- VOLTS

AMPERAGE DRAW ----- AMPS (COOL)

AMPERAGE DRAW ----- AMPS (HEAT)

COMPRESSOR

LOCKED ROTOR AMPS ----- AMPS

AMPERAGE DRAW ----- AMPS

INDOOR TEMPERATURES:

INDOOR AMBIENT TEMPERATURE ----- F

RELATIVE HUMIDITY (RH) INDOOR ----- %

DISCHARGE AIR TEMPERATURE (INDOOR) ----- F ----- F

RETURN AIR TEMPERATURE (INDOOR) ----- F ----- F

DIFFERENTIAL ----- F ----- F

OUTDOOR TEMPERATURE:

OUTDOOR AMBIENT TEMPERATURE ----- F

RH OUTDOOR (RELATIVE HUMIDITY) ----- %

CONDENSER:

DISCHARGE AIR TEMPERATURE ----- F ----- F

INTAKE AIR TEMPERATURE ----- F ----- F

DIFFERENTIAL ----- F ----- F

APPLICATION USE ----- ROOM (RESIDENTIAL OR COMMERCIAL)

COOLING OR HEATING AREA W ----- X L ----- X H ----- = SQ/CU/FT -----

This is a general guide. please consult manual J or M.

Sizing your air conditioner correctly is vital.

Sizing Guide

The following guide is based on normal room insulation, average number of sun-exposed windows and two-person occupancy.

FT ²	Btu/h
100-150	5,000
150-250	6,000
250-300	7,000
300-350	8,000
350-400	9,000
400-450	10,000
450-550	12,000
550-700	14,000
700-1,000	18,000
1,000-1,200	21,000
1,200-1,400	23,000
1,400-1,600	25,000
1,600-1,900	28,000
1,900-2,700	36,000

This is a general guide.

Please consult manual J or M for exact load calculations.

1. If heavily shaded, reduce capacity 10%.
2. If very sunny, add 10%.
3. Add 500 BTU/H per person over 2 people.
4. Add 4,000 BTU/H if area is a kitchen.

Due to variations in room design, climate zone and occupancy, larger areas may require the use of multiple units to provide the optimal cooling solution.

THERMISTORS' RESISTANCE VALUES (This Table Applies to All Thermistors)

FAHRENHEIT TEMP	RESISTANCE (K Ohms)			RESISTANCE TOLERANCE %	
0	92.411	97.662	102.912	5.38	5.38
5	78.541	82.812	87.083	5.16	5.16
10	66.866	70.339	73.812	4.94	4.94
15	57.039	59.864	62.688	4.72	4.72
20	48.763	51.060	53.357	4.50	4.50
25	41.786	43.654	45.523	4.28	4.28
30	35.896	37.415	38.934	4.06	4.06
31	34.832	36.290	37.747	4.02	4.02
32	33.803	35.202	36.601	3.97	3.97
33	32.808	34.150	35.492	3.93	3.93
34	31.846	33.133	34.421	3.89	3.89
35	30.916	32.151	33.386	3.84	3.84
36	30.016	31.200	32.385	3.80	3.80
37	29.144	30.281	31.418	3.75	3.75
38	28.319	29.425	30.534	3.76	3.77
39	27.486	28.532	29.579	3.67	3.67
40	26.697	27.701	28.704	3.62	3.62
45	23.116	23.931	24.745	3.40	3.40
50	20.071	20.731	21.391	3.18	3.18
55	17.474	18.008	18.542	2.96	2.96
60	15.253	15.684	16.115	2.75	2.75
65	13.351	13.697	14.043	2.53	2.53
66	13.004	13.335	13.666	2.48	2.48
67	12.668	12.984	13.301	2.44	2.44
68	12.341	12.644	12.947	2.39	2.39
69	12.024	12.313	12.603	2.35	2.35
70	11.716	11.993	12.269	2.31	2.31
71	11.418	11.682	11.946	2.26	2.26
72	11.128	11.380	11.633	2.22	2.22
73	10.846	11.088	11.329	2.18	2.18
74	10.574	10.804	11.034	2.13	2.13
75	10.308	10.528	10.748	2.09	2.09
76	10.051	10.260	10.469	2.04	2.04
77	9.800	10.000	10.200	2.00	2.00
78	9.550	9.748	9.945	2.03	2.03
79	9.306	9.503	9.699	2.07	2.07
80	9.070	9.265	9.459	2.10	2.10
81	8.841	9.033	9.226	2.13	2.13
82	8.618	8.809	9.000	2.17	2.17
83	8.402	8.591	8.780	2.20	2.20
84	8.192	8.379	8.566	2.23	2.23
85	7.987	8.172	8.358	2.27	2.27
86	7.789	7.972	8.155	2.30	2.30
87	7.596	7.778	7.959	2.33	2.33
88	7.409	7.589	7.768	2.37	2.37
89	7.227	7.405	7.583	2.40	2.40
90	7.050	7.226	7.402	2.43	2.43
91	6.878	7.052	7.226	2.47	2.47
92	6.711	6.883	7.055	2.50	2.50
93	6.548	6.718	6.889	2.53	2.53
94	6.390	6.558	6.727	2.57	2.57
95	6.237	6.403	6.569	2.60	2.60
96	6.087	6.252	6.417	2.63	2.63
97	5.942	6.105	6.268	2.67	2.67
98	5.800	5.961	6.122	2.70	2.70
99	5.663	5.822	5.981	2.73	2.73
100	5.529	5.686	5.844	2.77	2.77
105	4.912	5.060	5.208	2.93	2.93
110	4.371	4.511	4.651	3.10	3.10
115	3.898	4.030	4.161	3.27	3.27
120	3.482	3.606	3.730	3.43	3.43

ELECTRICAL TROUBLESHOOTING CHART - COOLING

9K BTU, 12K BTU, & 18K BTU



ELECTRICAL TROUBLESHOOTING CHART - COOLING 24K BTU



ELECTRICAL TROUBLESHOOTING CHART HEAT PUMP

HEAT PUMP MODE



TROUBLESHOOTING CHART - COOLING

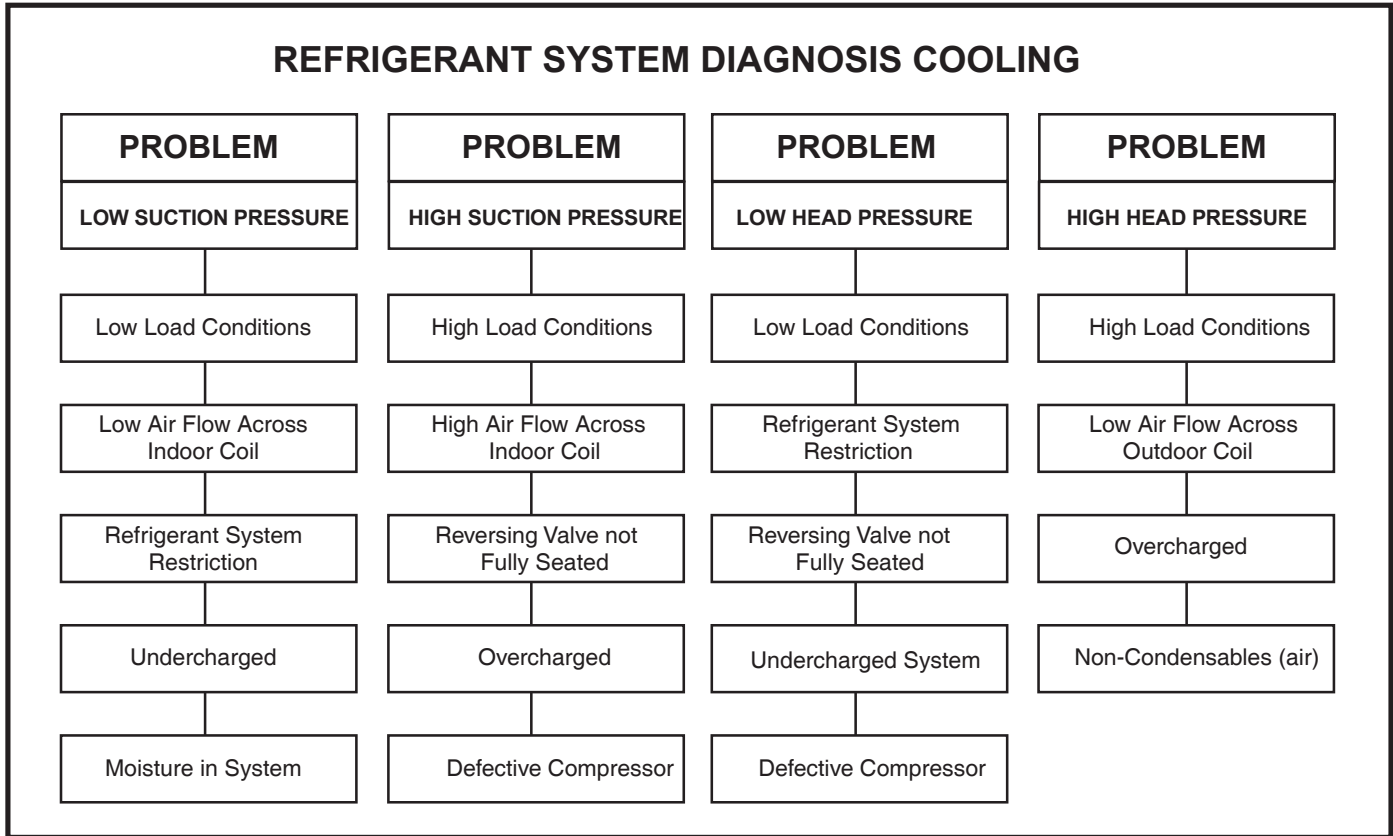

TROUBLESHOOTING CHART - HEATING (HEAT PUMP)

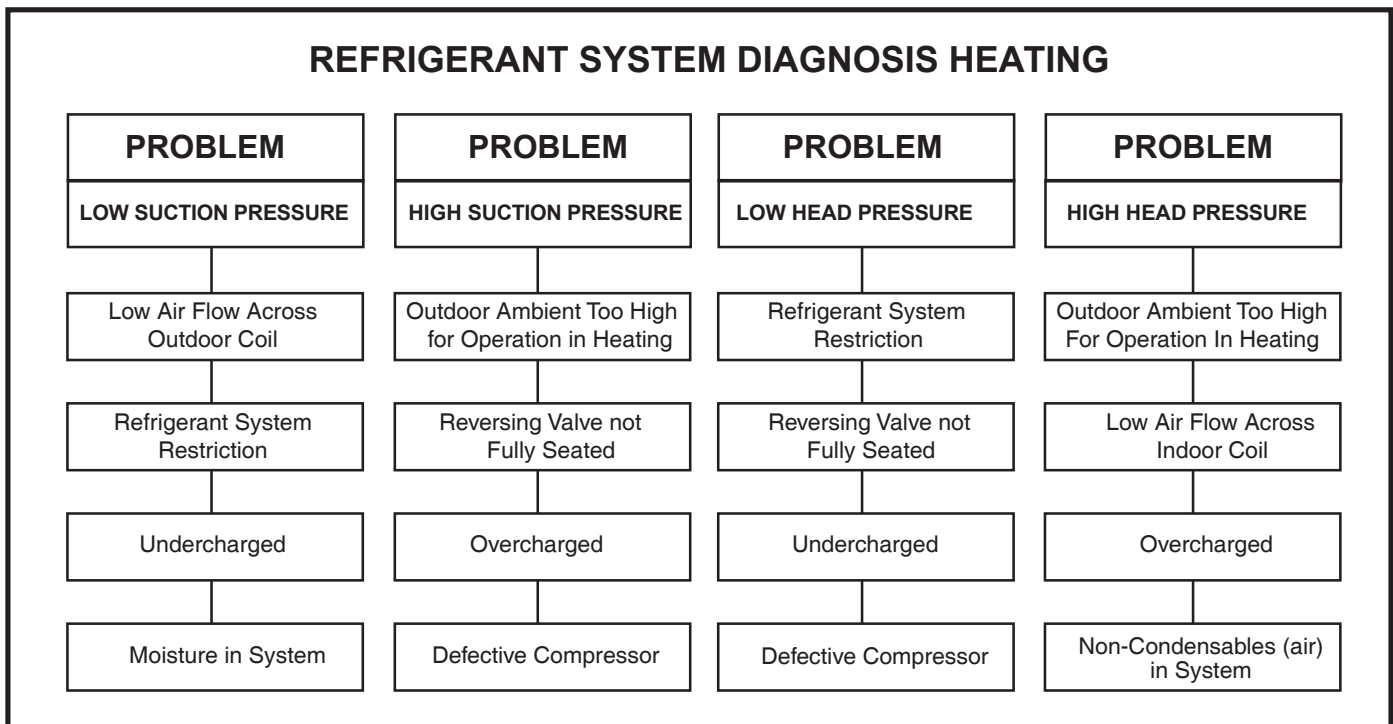

REMOTE WALL THERMOSTAT WIRING DIAGRAMS

LEGEND FOR T-STAT WIRING HARNESS

R	24 VAC Power From Unit
C	Common Terminal
GL	Call for Low Fan
GH	Call for High Fan
O/B	Reversing Valve - Configurable
O	Cool mode, active reversing valve
B	Heat mode, active reversing valve for VPAK heat pump unit
Y	Coil for Cooling
W	Call for Heat
RT6 - Two Speeds Fan T-Stat - Field Provided ----- Field Wiring	

COOL WITH ELECTRIC HEAT

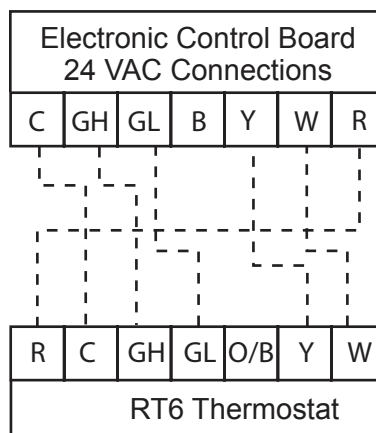

HEAT PUMP WITH ELECTRIC HEAT

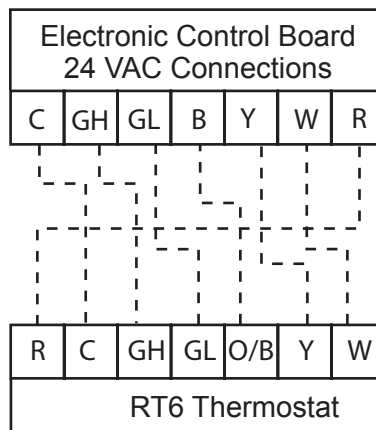

COOL WITH ELECTRIC HEAT ELECTRICAL & THERMOSTAT WIRING DIAGRAM VEA 09/12/18 with 2.5 KW, 3.4 KW or 5KW ELECTRIC HEAT

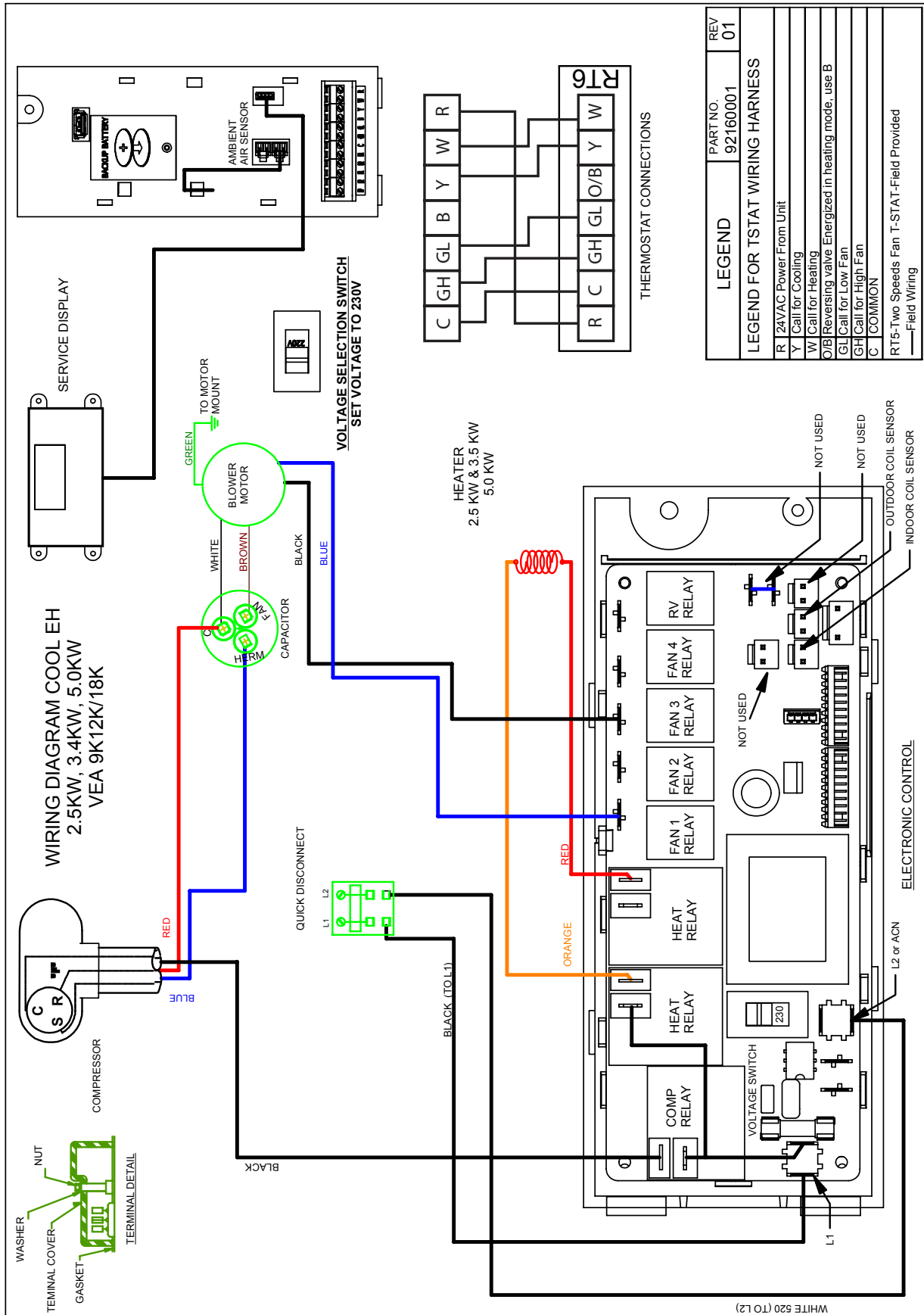





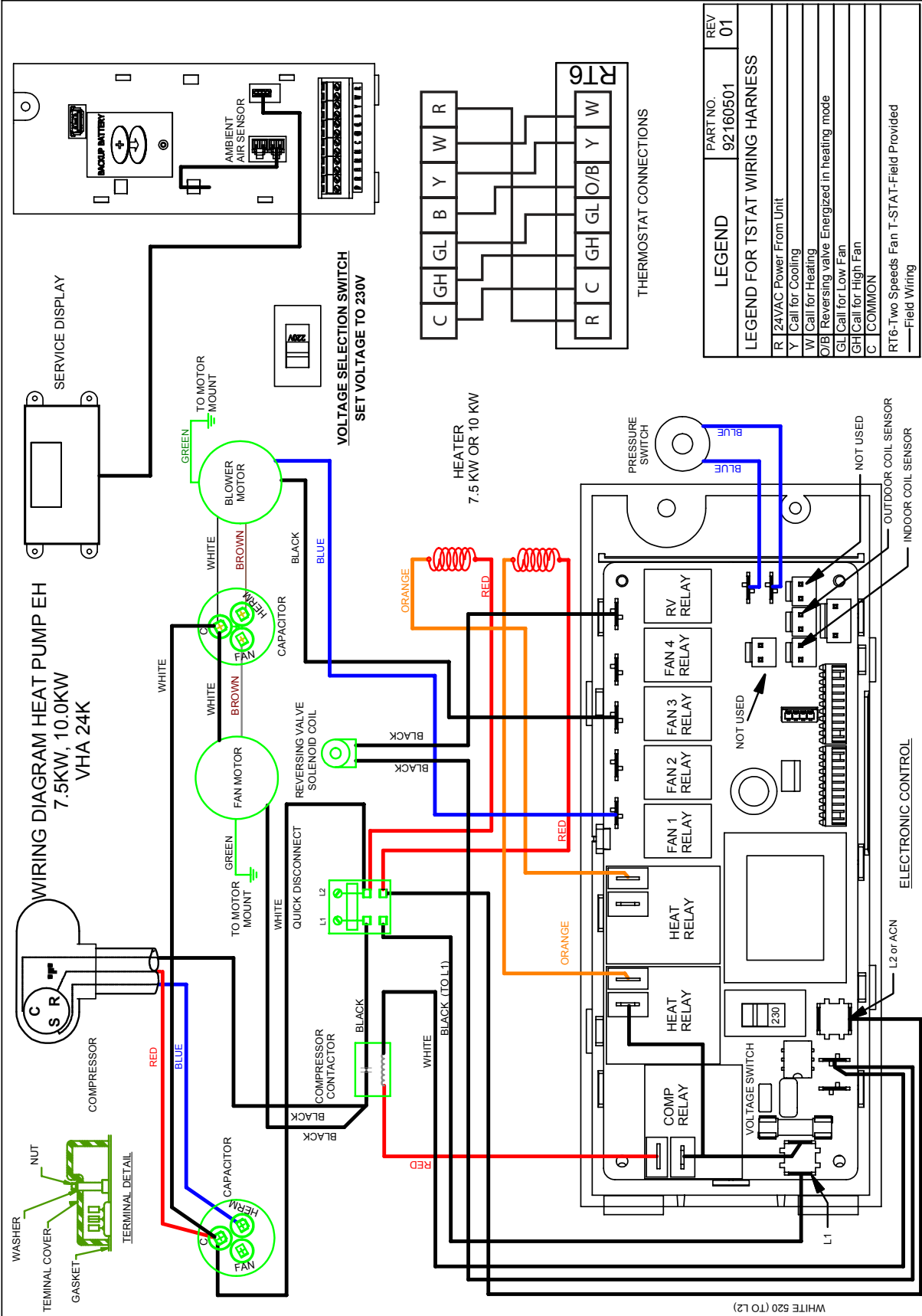

COOL WITH ELECTRIC HEAT ELECTRICAL & THERMOSTAT WIRING DIAGRAM VEA 24 with 7.5 KW and 10 KW ELECTRIC HEAT



HEAT PUMP WITH ELECTRIC HEAT ELECTRICAL & THERMOSTAT WIRING DIAGRAM VHA 24 with 7.5 KW and 10KW ELECTRIC HEAT

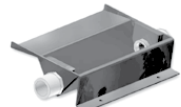

Accessories

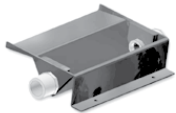
MODEL	DESCRIPTION	PHOTO
VPAWP1-8	<p>WALL PLENUM Two-part sleeve that telescopes in and out from 5 1/2" to 8" in depth. The wall plenum sits inside the exterior wall penetration.</p> <p>DIMENSIONS: 30 3/8" high x 24 1/8" wide CUTOUT DIMENSIONS: 30 7/8" high x 24 5/8" wide.</p>	
VPAWP1-14	Same as VPAWP1-8, but telescopes 8' to 14' as required.	
VPAL2	<p>ARCHITECTURAL LOUVER Extruded aluminum louver that attaches to the outdoor section of the wall plenum.</p> <p>DIMENSIONS: 31 1/16" high x 25 9/16" wide.</p>	
VPSC2	Same as VPAL2 but can be ordered in a special color to match the exterior wall.	
RT4	<p>DIGITAL REMOTE WALL THERMOSTAT Single stage thermostat, used on VERT-I-PAK units. Hard wired with single speed fan. Direct replacement for RT2.</p>	
RT6	<p>DIGITAL REMOTE WALL THERMOSTAT Single stage cool, single stage heat thermostat. Features high/low fan speed switch, Hi/Low temperature limiting. Thermostat is hard wired and is unit powered. Features backlight display and multiple configuration.</p>	
VPRG4	<p>ACCESS PANEL / RETURN AIR GRILLE - Serves as an access panel to chassis and interior return air grille. A field-supplied (25" x 20") filter is mounted inside the hinged access door.</p> <p>Kit contains hinge bracket for mounting the door with the return air openings high or low on the door for optimal sound attenuation.</p> <p>For 9,000 / 12,000 / 18,000 Btu models, it is recommended to install the door with the hinge on the right side and the return air openings high on the door. For 24,000 Btu models, it is recommended to install the hinge on the left side with the return air openings low on the door.</p> <p>DIMENSIONS: 58" high x 29" wide. CUTOUT DIMENSIONS: 55 3/4" high x 27" wide.</p>	
VPDP1	<p>DRAIN PAN Drain pan may be installed prior to chassis for easy installation/removal. For VPAK 24K only.</p>	



F R I E D R I C H

Friedrich Air Conditioning Company

10001 Reunion Place, Suite 500

San Antonio, Tx 78216

1-800-541-6645

www.friedrich.com

VERT-I-PAK[®] A SERIES SINGLE PACKAGE VERTICAL AIR CONDITIONERS LIMITED WARRANTY

SAVE THIS CERTIFICATE. It gives you specific rights, you may also have other rights which may vary from state to state and province to province.

In the event that your unit needs servicing, contact your nearest authorized service center. If you do not know the nearest service center, ask the company that installed your unit or contact us - see address and telephone number above. To obtain service and/or warranty parts replacement, you must notify an authorized FRIEDRICH Air Conditioning Co. service center, distributor, dealer, or contractor of any defect within the applicable warranty period.

When requesting service: please have the model and serial number from your unit readily available.

Unless specified otherwise herein, the following applies:

FRIEDRICH VERT-I-PAK A SERIES VERTICAL AIR CONDITIONERS AND HEAT PUMPS

LIMITED WARRANTY - FIRST YEAR (Twelve (12) months from the date of installation). Any part found to be defective in the material or workmanship will be repaired or replaced free of charge by our authorized service center during the normal working hours; and

LIMITED WARRANTY - SECOND THROUGH FIFTH YEAR (Sixty (60) months from the date of installation). ON THE SEALED REFRIGERATION SYSTEM. Any part of the sealed refrigeration system that is defective in material or workmanship will be repaired or replaced free of charge (excluding freight charges) by our authorized service center during normal working hours. The sealed refrigeration system consists of the compressor, metering device, evaporator, condenser, reversing valve, check valve, and the interconnecting tubing.

These warranties apply only while the unit remains at the original site and only to units installed inside the continental United States, Alaska, Hawaii, Puerto Rico, Mexico and Canada. The warranty applies only if the unit is installed and operated in accordance with the printed instructions and in compliance with applicable local installation and building codes and good trade practices. For international warranty information, contact the Friedrich Air Conditioning Company - International Division.

Any defective part to be replaced must be made available to **FRIEDRICH** in exchange for the replacement part. Reasonable proof must be presented to establish the date of install, otherwise the beginning date of this certificate will be considered to be our shipment date plus sixty days. Replacement parts can be new or remanufactured. Replacement parts and labor are only warranted for any unused portion of the unit's warranty.

We will not be responsible for and the user will pay for:

1. Service calls to:
 - A) Instruct on unit operation. B) Replace house fuses or correct house wiring. C) Clean or replace air filters. D) Remove the unit from its installed location when not accessible for service required. E) Correct improper installations.
2. Parts or labor provided by anyone other than an authorized service center.
3. Damage caused by:
 - A) Accident, abuse, negligence, misuse, riot, fire, flood, or acts of God. B) Operating the unit where there is a corrosive atmosphere containing chlorine, fluorine, or any damaging chemicals (other than in a normal residential environment). C) Unauthorized alteration or repair of the unit, which in turn affects its stability or performance. D) Failing to provide proper maintenance and service. E) Using an incorrect power source. F) Faulty installation or application of the unit.

We shall not be liable for any incidental, consequential, or special damages or expenses in connection with any use or failure of this unit. We have not made and do not make any representation or warranty of fitness for a particular use or purpose and there is no implied condition of fitness for a particular use or purpose. We make no expressed warranties except as stated in this certificate. No one is authorized to change this certificate or to create for us any other obligation or liability in connection with this unit. Any implied warranties shall last for one year after the original purchase date. Some states and provinces do not allow limitations on how long an implied warranty or condition lasts, so the above limitations or exclusions may not apply to you. The provisions of this warranty are in addition to and not a modification of or subtraction from the statutory warranties and other rights and remedies provided by law.

Performance of Friedrich's Warranty obligation is limited to one of the following methods:

1. Repair of the unit
2. A refund to the customer for the prorated value of the unit based upon the remaining warranty period of the unit.
3. Providing a replacement unit of equal value

The method of fulfillment of the warranty obligation is at the sole discretion of Friedrich Air Conditioning

In case of any questions regarding the provisions of this warranty, the English version will govern.

(10-06)

2011 VPAK 9K-18K BTU/h Models

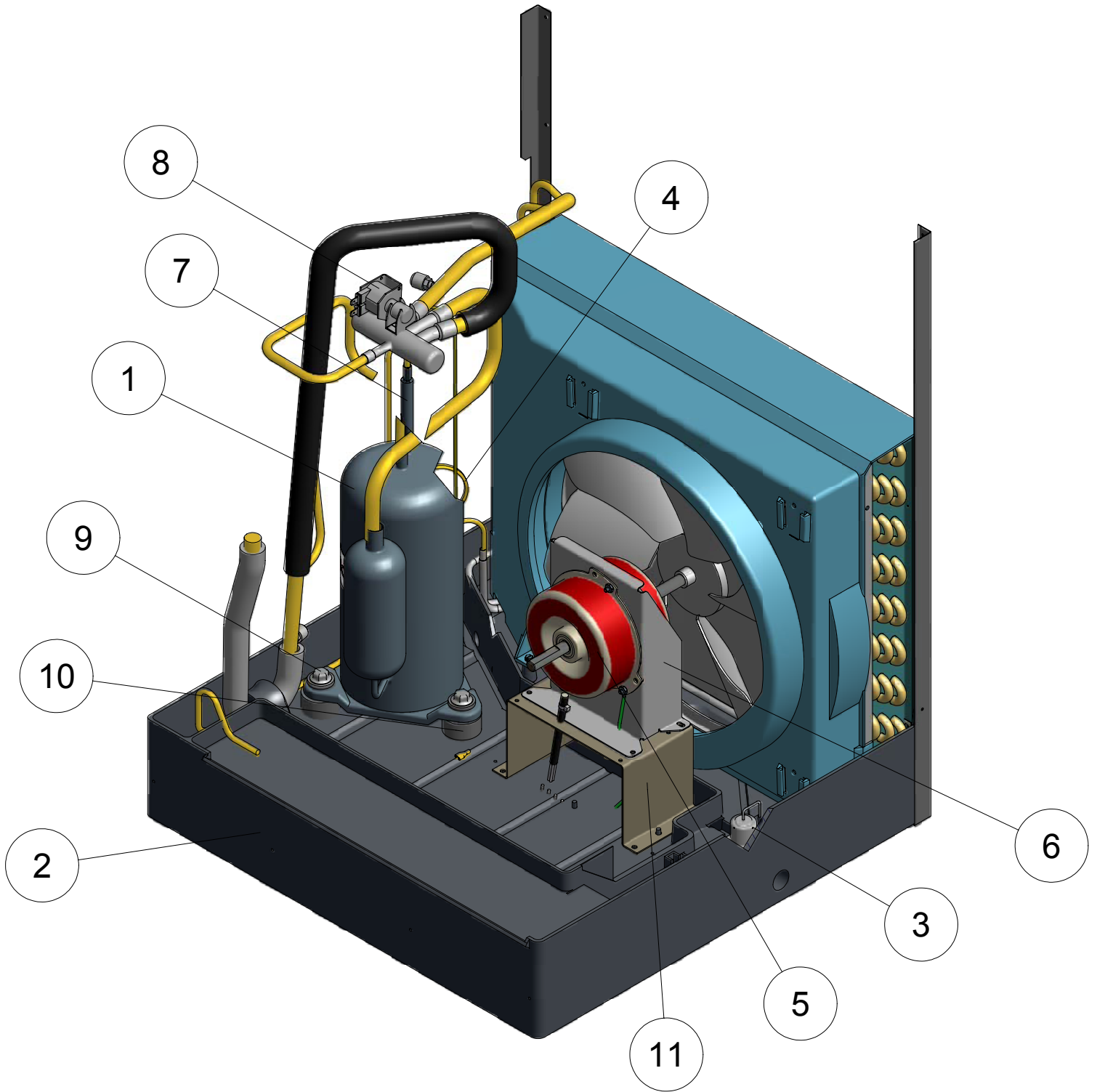

2011 VPAK 9K-18K BTU/h Models

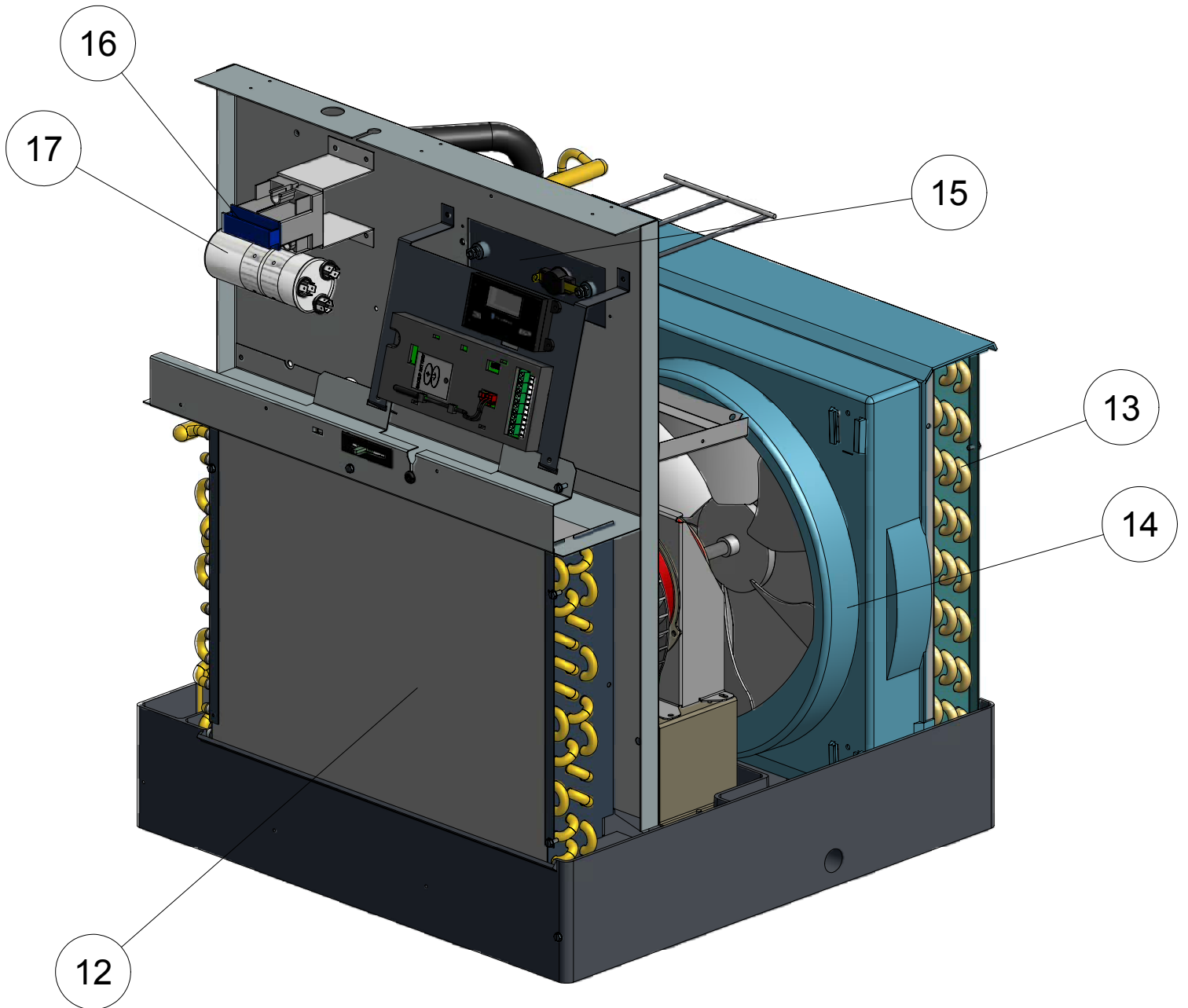

2011 VPAK 9K-18K BTU/h Models



9K-18K BTU/h Models 2011 VPAK Parts List

Reference Number	Part Number	Part Description	Model																		
			VEA09K25RTL-B	VEA09K34RTL-B	VEA09K50RTL-B	VEA12K25RTL-B	VEA12K34RTL-B	VEA12K50RTL-B	VEA18K25RTL-B	VEA18K34RTL-B	VEA18K50RTL-B	VHA09K25RTL-B	VHA09K34RTL-B	VHA09K50RTL-B	VHA12K25RTL-B	VHA12K34RTL-B	VHA12K50RTL-B	VHA18K25RTL-B	VHA18K34RTL-B	VHA18K50RTL-B	
1	80074936	COMPRESSOR KIT	1	1	1																
1	80074939	COMPRESSOR KIT															1	1	1		
1	80074938	COMPRESSOR KIT								1	1	1							1	1	1
1	80074937	COMPRESSOR KIT				1	1	1													
1	80077146	COMPRESSOR KIT											1	1	1						
2	80023703	BASEPAN VPAK	1	1	1	1	1	1				1	1	1							
2	80023702	BASEPAN VPAK							1	1	1					1	1	1			
3	60179904	CONDENSATE DRAIN VALVE	1	1	1	1	1	1	1	1	1	1	1	1	1	1	1	1	1	1	1
4	01389903	TUBE CAP (Cooling)	1	1	1																
4	03760473	TUBE CAP (Cooling)				1	1	1													
4	01389915	TUBE CAP (Cooling)							1	1	1										
4	01389985	TUBE CAP (Cooling)							1												
4	03760513	TUBE CAP (Heating)										1	1	1							
4	03760518	TUBE CAP (Cooling)										1	1	1							
4	01390212	TUBE CAP (Cooling)														1	1	1			
4	03760511	TUBE CAP (Heating)														1	1	1			
5	80006870	FAN MOTOR	1	1	1	1	1	1	1	1	1	1	1	1	1	1	1	1	1	1	1
6	61776900	MOTOR MOUNT XQ	1	1	1	1	1	1	1	1	1	1	1	1	1	1	1	1	1	1	1
7	25076004	VALVE CHECK										1	1	1							
7	25076003	VALVE CHECK														1	1	1	1	1	1
8	25022022	VALVE REV 4-WAY DUNAN										1	1	1	1	1	1				
8	25022032	VALVE REV 4-WAY DUNAN																	1	1	1
9	91400400	COMPRESSOR STUD	3	3	3	3	3	3	3	3	3	3	3	3	3	3	3	3	3	3	3
10	61028900	COMPRESSOR GROMMET	3	3	3	3	3	3	3	3	3	3	3	3	3	3	3	3	3	3	3
11	80050200	MOTOR RISER	1	1	1	1	1	1	1	1	1	1	1	1	1	1	1	1	1	1	1
12	80041750	COIL, EVAPORATOR	1	1	1	1	1	1				1	1	1							
12	80048150	COIL, EVAPORATOR							1	1	1					1	1	1	1	1	1
13	80041960	COIL, CONDENSER	1	1	1											1	1	1	1	1	1
13	80041971	COIL, CONDENSER				1	1	1								1	1	1	1	1	1
13	80041970	COIL, CONDENSER										1	1	1							
13	80048050	COIL, CONDENSER							1	1	1										
*	61834800	STRAINER .312 COIL	1	1	1	1	1	1				1	1	1	1	1	1	1	1	1	1
*	61834801	STRAINER .375 COIL							1	1	1					1	1	1	1	1	1
14	61804901	SHROUD MED W/FD RESTRAINT	1	1	1	1	1	1	1	1	1	1	1	1	1	1	1	1	1	1	1
15	80017090	HEATER VPAK-A NXT 2.5KW 230V	1			1			1			1				1			1		
15	80017091	HEATER VPAK-A NXT 3.4KW 230V		1			1			1			1				1			1	
15	80017092	HEATER VPAK-A NXT 5.0KW 230V			1			1			1			1				1			1
16	80007600	NONFUSED DISCONNECT	1	1	1	1	1	1	1	1	1	1	1	1	1	1	1	1	1	1	1
17	61080521	CAPCTR 25/10 MF 450V				1	1	1				1	1	1							
17	61080558	CAPCTR 30/10 MF 370V	1	1	1																
17	61080554	CAPCTR 40/10 MF 370V							1	1	1					1	1	1	1	1	1
18	62601008	E-CONTROL MAIN BOARD (Electric Heat)	1	1	1	1	1	1	1	1	1										
18	62601009	E-CONTROL MAIN BOARD (Heat Pump)										1	1	1	1	1	1	1	1	1	1
*	62600203	Sensor ID R/A Temperature (Return Air)	1	1	1	1	1	1	1	1	1	1	1	1	1	1	1	1	1	1	1
*	62600205	Sensor ID Coil Temperature (Evaporator)	1	1	1	1	1	1	1	1	1	1	1	1	1	1	1	1	1	1	1
*	62600206	Sensor OD Coil Temperature (Condensor)	1	1	1	1	1	1	1	1	1	1	1	1	1	1	1	1	1	1	1
19	62600600	DISPLAY SERVICE VPAC KUHL	1	1	1	1	1	1	1	1	1	1	1	1	1	1	1	1	1	1	1
20	80050601	BRACKET ELECT CTRL KUHL	1	1	1	1	1	1	1	1	1	1	1	1	1	1	1	1	1	1	1
21	60610601	BLOWER WHEEL														1	1	1			
21	60610607	BLOWER WHEEL				1	1	1													
21	60610605	BLOWER WHEEL	1	1	1				1	1	1	1	1	1					1	1	1
22	60542004	FAN PLASTIC 14.5" TA1004	1	1	1	1	1	1	1	1	1	1	1	1	1	1	1	1	1	1	1
23	80049601	INSUL ASY, LFT FRONT PNL	1	1	1	1	1	1	1	1	1	1	1	1	1	1	1	1	1	1	1
24	80013807	INSUL ASY RIGHT SIDE PANEL	1	1	1	1	1	1	1	1	1	1	1	1	1	1	1	1	1	1	1
25	80001800	COLLAR 24 GA.	1	1	1	1	1	1	1	1	1	1	1	1	1	1	1	1	1	1	1
26	80013502	INSUL ASY TOP COVER	1	1	1	1	1	1	1	1	1	1	1	1	1	1	1	1	1	1	1
27	61656200	CHANNEL EXHAUST DOOR	1	1	1	1	1	1	1	1	1	1	1	1	1	1	1	1	1	1	1
*	61656201	SLIDE EXHAUST DOOR	1	1	1	1	1	1	1	1	1	1	1	1	1	1	1	1	1	1	1
28	80013805	INSUL ASY LEFT SIDE PANEL	1	1	1	1	1	1	1	1	1	1	1	1	1	1	1	1	1	1	1
*	61814800	CONNECTOR FRESH AIR S/M	1	1	1	1	1	1	1	1	1	1	1	1	1	1	1	1	1	1	1
*	80029207	ISOLATOR PAD	2	2	2	2	2	2	2	2	2	2	2	2	2	2	2	2	2	2	2
*	61764588	OVERLOAD FSTB B128-155-241E	1	1	1																
*	61764585	OVERLOAD MRA12030-12008				1	1	1													
*	61764562	OVERLOAD MRA12177-12008										1	1	1							

2011 VPAK 24K BTU/h Models

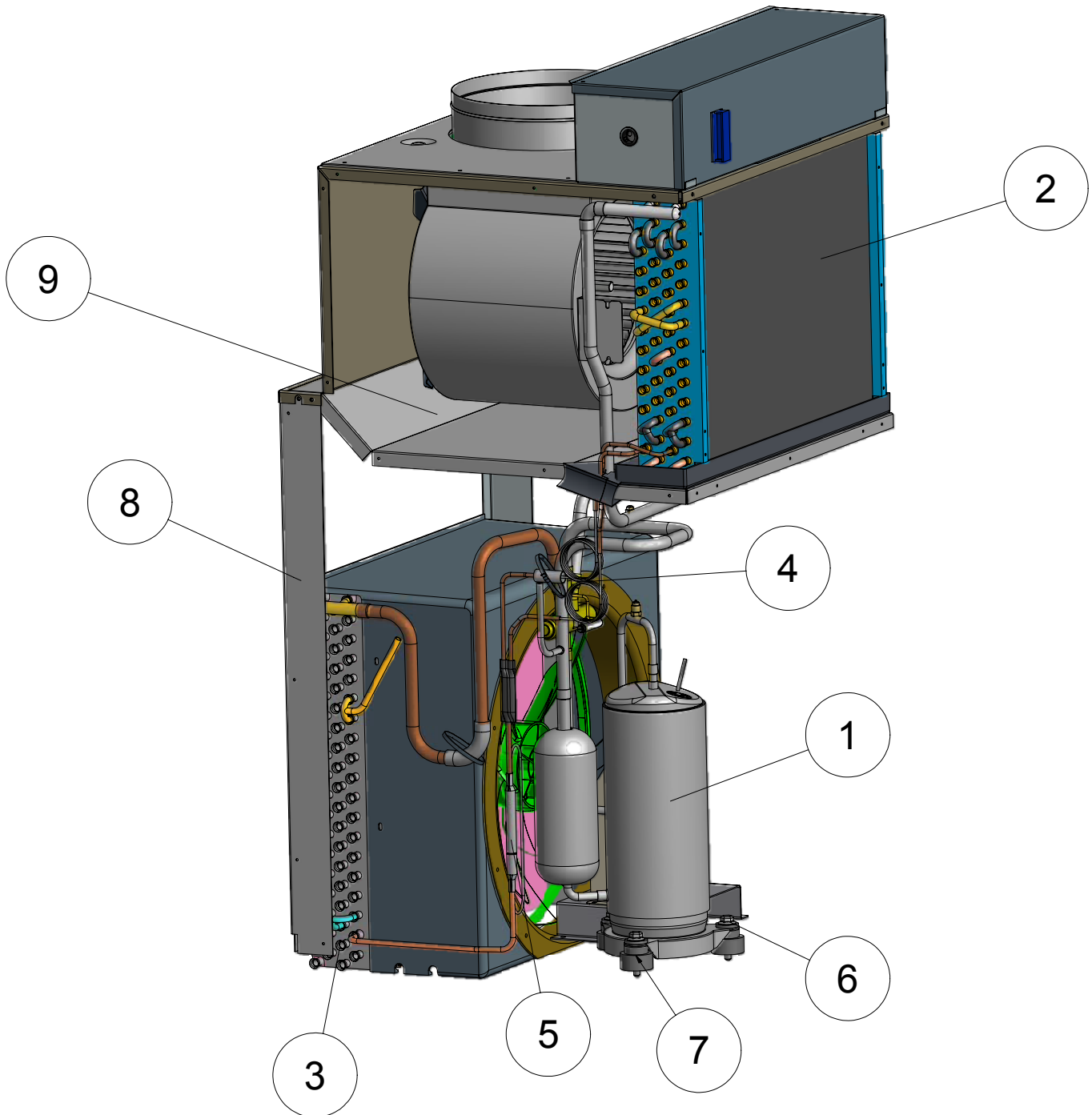

2011 VPAK 24K BTU/h Models

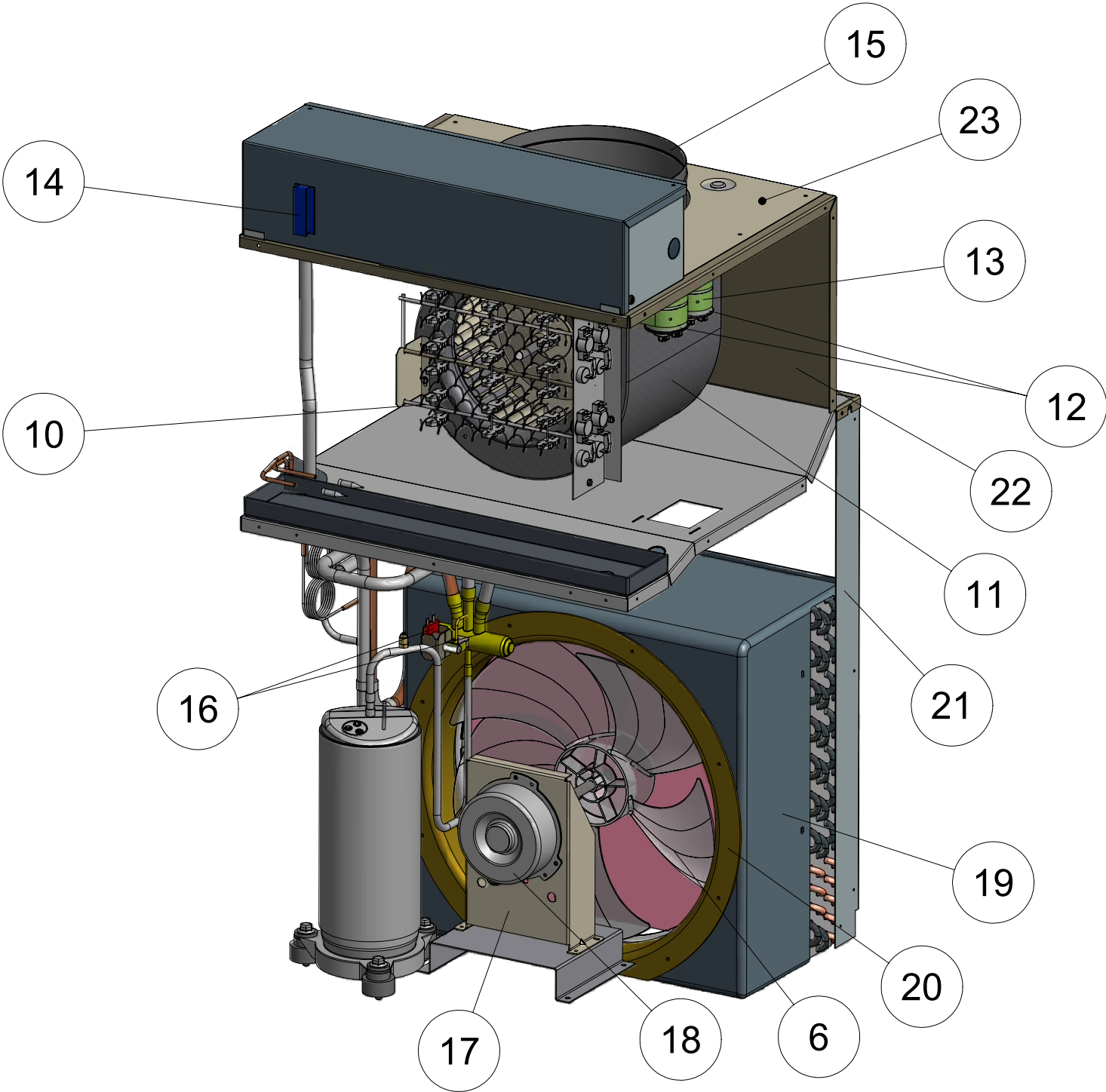

2011 VPAK 24K BTU/h Models

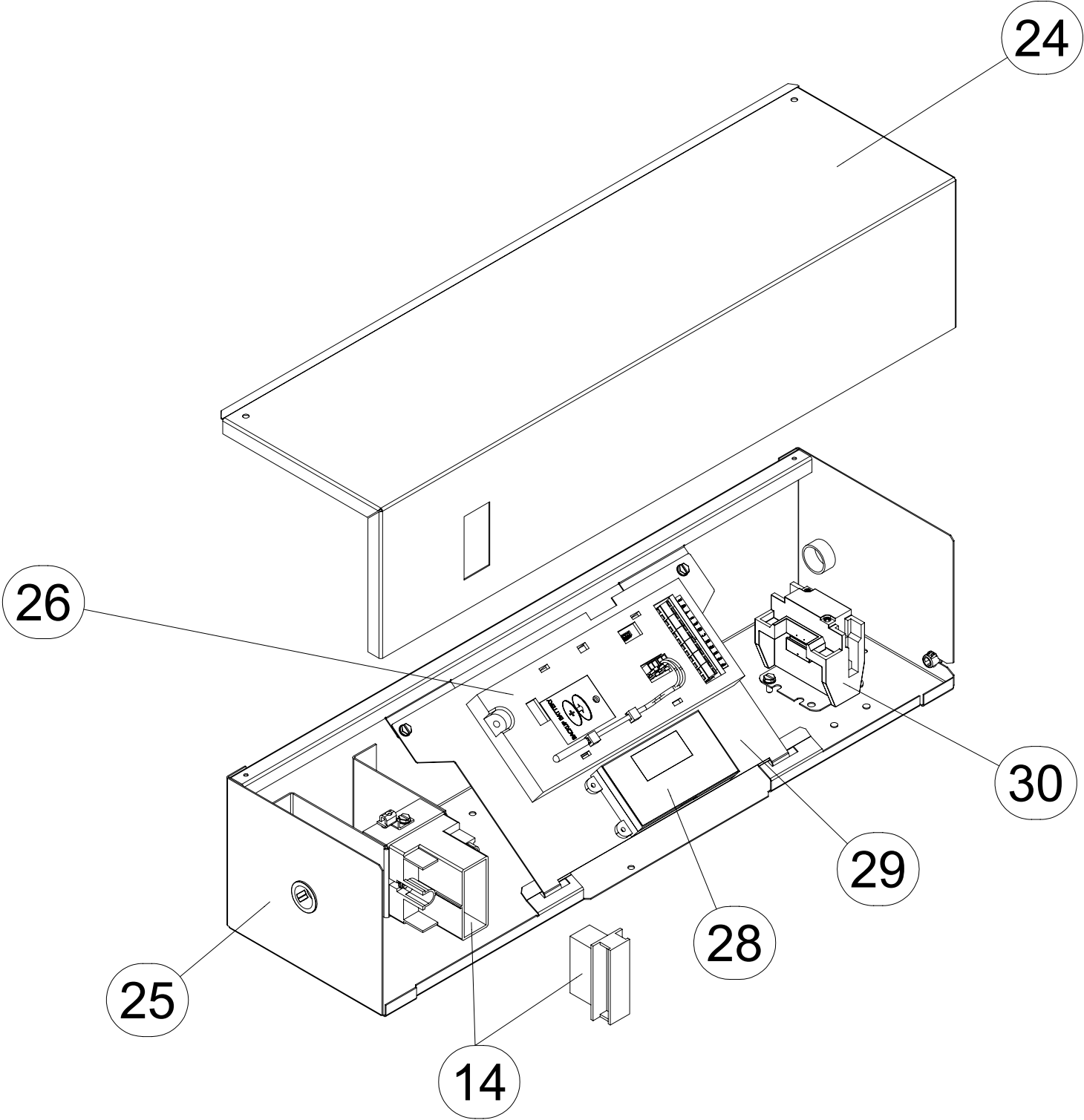

2011 VPAK 24K BTU/h Models

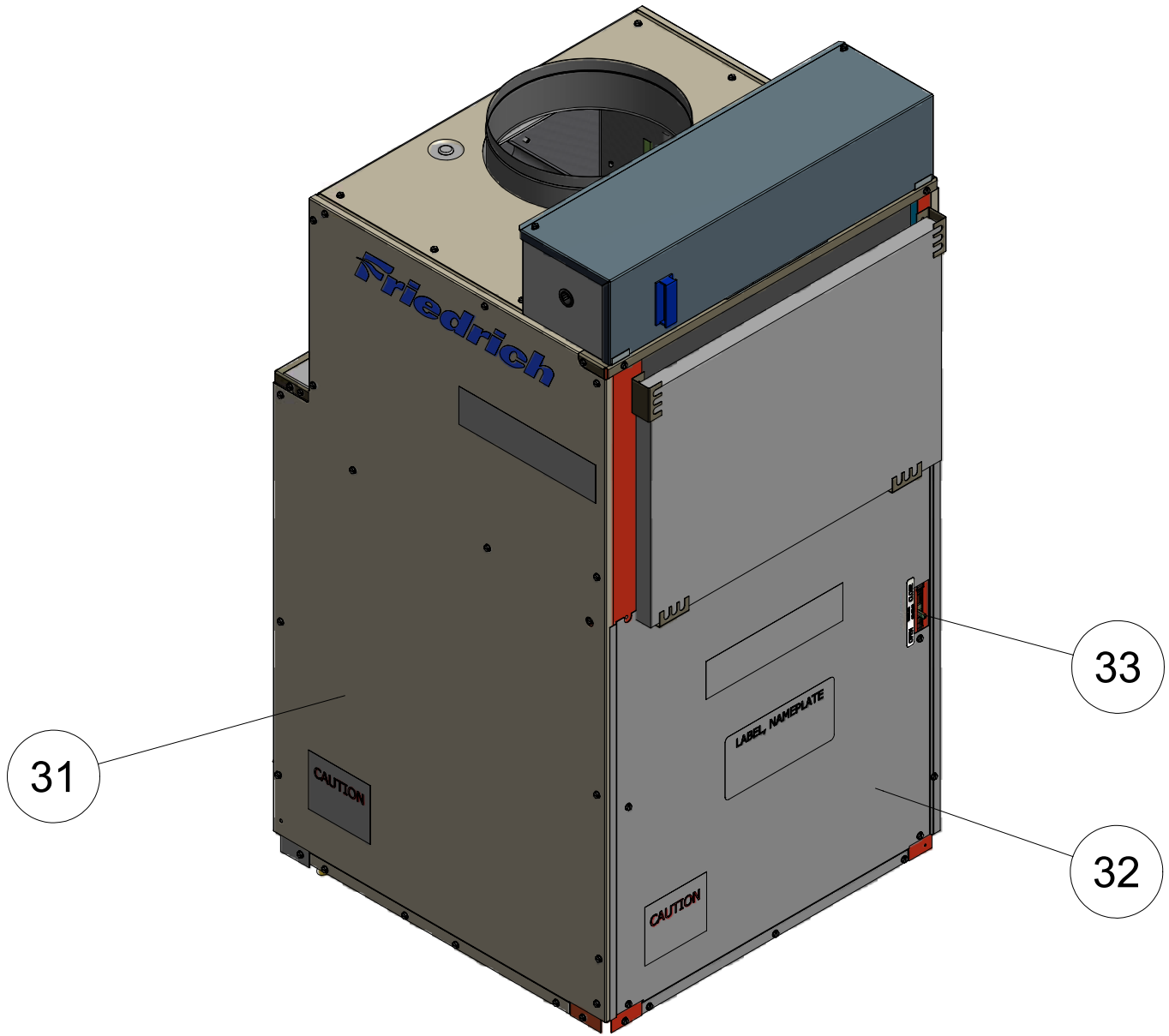

24K BTU/h Models 2011 VPAK Parts List

Reference Number	Part Number	Part Description	Model											
			VEA24K10RTL-B	VEA24K25RTL-B	VEA24K34RTL-B	VEA24K50RTL-B	VEA24K75RTL-B	VHA24K10RTL-B	VHA24K25RTL-B	VHA24K34RTL-B	VHA24K50RTL-B	VHA24K75RTL-B		
1	80077118	COMPRESSOR KIT	1	1	1	1	1	1	1	1	1	1	1	1
2	80103450	COIL, EVAPORATOR	1	1	1	1	1	1	1	1	1	1	1	1
3	80101261	COIL, CONDENSER							1	1	1	1	1	1
3	80101260	COIL, CONDENSER	1	1	1	1	1							
*	61834800	STRAINER .312 COIL	1	1	1	1	1	1	1	1	1	1	1	1
*	61834801	STRAINER .375 COIL							1	1	1	1	1	1
4	03760548	TUBE CAP (Cooling)	2	2	2	2	2	2	2	2	2	2	2	2
4	03760507	TUBE CAP (Heating)							1	1	1	1	1	1
5	25076005	VALVE CHECK							1	1	1	1	1	1
6	60542007	FAN PLASTIC 16" LRG; VPAC	1	1	1	1	1	1	1	1	1	1	1	1
6	91400400	STUD COMPR MTG	3	3	3	3	3	3	3	3	3	3	3	3
7	01150934	GROMMET COMP. #64041	3	3	3	3	3	3	3	3	3	3	3	3
8	80101400	LOWER RIGHT POST	1	1	1	1	1	1	1	1	1	1	1	1
9	80106201	INNER WALL	1	1	1	1	1	1	1	1	1	1	1	1
10	80102294	HEATER VPAK-A24 NXT 10.0KW 230V	1						1					
10	80102290	HEATER VPAK-A24 NXT 2.5KW 230V		1						1				
10	80102291	HEATER VPAK-A24 NXT 3.4KW 230V			1						1			
10	80102292	HEATER VPAK-A24 NXT 5.0KW 230V				1						1		
10	80102293	HEATER VPAK-A24 NXT 7.5KW 230V					1						1	
11	80103200	BLOWER HOUSING	1	1	1	1	1	1	1	1	1	1	1	1
*	80106970	MTR 1/4 4 6P CW 1PSC 15.0 BLO WEL (Evap)	1	1	1	1	1	1	1	1	1	1	1	1
12	61080573	CAPCTR 15/5 MF 440V	1	1	1	1	1	1	1	1	1	1	1	1
12	61080580	CAPCTR 50/5/370VAC	1	1	1	1	1	1	1	1	1	1	1	1
13	20709185	CAPACITOR BRACKET	1	1	1	1	1	1	1	1	1	1	1	1
14	80007600	NONFUSED DISCONNECT	1	1	1	1	1	1	1	1	1	1	1	1
15	80001800	COLLAR 24 GA.	1	1	1	1	1	1	1	1	1	1	1	1
16	25022032	VALVE REV 4-WAY DUNAN							1	1	1	1	1	1
17	25014400	MOTOR MOUNT	1	1	1	1	1	1	1	1	1	1	1	1
18	80102170	MTR 1/4 4 6P CCW 1PSC 5.0 BLO WEL	1	1	1	1	1	1	1	1	1	1	1	1
19	80114100	91 SHROUD ASY VPAK 24	1	1	1	1	1	1	1	1	1	1	1	1
20	80101010	SHROUD RING VPAK24	1	1	1	1	1	1	1	1	1	1	1	1
21	80101300	LOWER LEFT POST	1	1	1	1	1	1	1	1	1	1	1	1
22	80106701	INSULATED TOP ASSY	1	1	1	1	1	1	1	1	1	1	1	1
23	80113200	TOP COVER INSUL ASYU	1	1	1	1	1	1	1	1	1	1	1	1
*	80101500	UPPER LEFT POST	1	1	1	1	1	1	1	1	1	1	1	1
*	80101600	UPPER RIGHT POST	1	1	1	1	1	1	1	1	1	1	1	1
24	80116601	CONTROL BOX COVER	1	1	1	1	1	1	1	1	1	1	1	1
25	80118400	CONTROL BOX	1	1	1	1	1	1	1	1	1	1	1	1
26	62601008	E-CONTROL MAIN BOARD (Electric Heat)	1	1	1	1	1							
26	62601009	E-CONTROL MAIN BOARD (Heat Pump)							1	1	1	1	1	1
*	62600203	Sensor ID R/A Temperature (Return Air)	1	1	1	1	1	1	1	1	1	1	1	1
*	62600205	Sensor ID Coil Temperature (Evaporator)	1	1	1	1	1	1	1	1	1	1	1	1
*	62600206	Sensor OD Coil Temperature (Condensor)	1	1	1	1	1	1	1	1	1	1	1	1
28	62600600	DISPLAY SERVICE VPAC KUHL	1	1	1	1	1	1	1	1	1	1	1	1
29	80116901	BRACKET ELECT CNTRL KUHL	1	1	1	1	1	1	1	1	1	1	1	1
30	80118600	CONTACTOR 240V	1	1	1	1	1	1	1	1	1	1	1	1
31	80106400	INSUL ASY RT PANEL	1	1	1	1	1	1	1	1	1	1	1	1
32	80106600	INSUL ASY REAR PANEL	1	1	1	1	1	1	1	1	1	1	1	1
33	61656200	CHANNEL EXHAUST DOOR	1	1	1	1	1	1	1	1	1	1	1	1
	61656201	SLIDE EXHAUST DOOR	1	1	1	1	1	1	1	1	1	1	1	1
	60179904	CONDENSATE DRAIN VALVE	1	1	1	1	1	1	1	1	1	1	1	1
	80115225	BASEPAN ASY PAINT & CAULK	1	1	1	1	1	1	1	1	1	1	1	1
	80103600	BLOWER BRACKET	2	2	2	2	2	2	2	2	2	2	2	2
	61814801	CONNECTOR FRESH AIR LRG	1	1	1	1	1	1	1	1	1	1	1	1
	80106500	INSUL ASY LT PANEL	1	1	1	1	1	1	1	1	1	1	1	1
	61828203	LIQUID LINE DRIER	1	1	1	1	1							
	61828204	LIQUID LINE DRIER (HEATPUMP)							1	1	1	1	1	1

CUSTOMER SATISFACTION and QUALITY ASSURANCE

Friedrich is a conscientious manufacturer, concerned about customer satisfaction, product quality, and controlling warranty costs. As an Authorized Service Provider you play a vital role in these areas. By adhering to the policies and procedures you provide us with vital information on each warranty repair you complete. This information is used to identify product failure trends, initiate corrective action, and improve product quality, thereby further reducing warranty expenses while increasing customer satisfaction levels.

FRIEDRICH AUTHORIZED PARTS DEPOTS

AAA Refrigeration Service

1322 24th Street, Suite B
Kenner, Louisiana 70062
504-464-7444
877-813-7444

The Gabbert Company

6868 Ardmore
Houston, Texas 77054
713-747-4110
800-458-4110

Reeve Air Conditioning, Inc.

2501 South Park Road
Hallandale, Florida 33009
954-962-0252
800-962-3383

Alamo Service Company

1450 North Flores Street
San Antonio, Texas 78212
210-227-2450
800-328-2450

Johnstone Supply of Woodside

27-01 Brooklyn Queens Expway
Woodside, New York 11377
718-545-5464
800-431-1143

TECHNICAL SUPPORT CONTACT INFORMATION



F R I E D R I C H

FRIEDRICH AIR CONDITIONING CO.

10001 Reunion Place, Ste. 500, San Antonio, TX 78216
(210) 546-0500 877-599-5665 x 261 FAX (210) 546-0631
Email: tac@friedrich.com
www.friedrich.com

Printed in the U.S.A.



F R I E D R I C H

FRIEDRICH AIR CONDITIONING CO.

10001 Reunion Place, Ste. 500, San Antonio, TX 78216

P 210-546-0500 | F 210-546-0731

www.friedrich.com

Printed in the U.S.A.

VPK-ServMan-L (4-11)