

This Owner's Manual is provided and hosted by [Appliance Factory Parts](#).



# MIDEA MP12HMC62-1 Owner's Manual

[Shop genuine replacement parts for MIDEA  
MP12HMC62-1](#)



[Find Your MIDEA Dehumidifier Parts - Select From 152 Models](#)

----- Manual continues below -----



# **SERVICE MANUAL**

# **PTACSERIES**

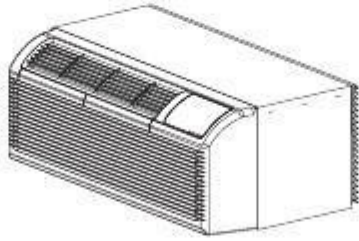

**7,000-15,000 BTU/H**



# CONTENTS

1. Precaution	1-3
1.1 Safety Precaution	1
1.2 Warning	1-3
2. Dimensions	3
3. Unit Components	4
4. Installation Details	5-15
4.1 How to Install Unit	5-7
4.2 Care and Cleaning	7-8
4.3 Other Installations	9-15
5. Functions and Control Panel	16-20
6. Refrigerant Cycle Diagram	21
7. Electronic Function	21-25
7.1 Terms and Definitions	21
7.2 Electric Control Working Environment	22
7.3 Protection Function	22
7.4 Operation of Fan Motor	22-23
7.5 Operation of Compressor	24-25
7.6 DIP Switches and Jumper Selection	25
8. Operations Characteristics	25
8.1 Cooling Operation	25
8.2 Heating Operation	25
9. Power Connection Options	26-27
10. Troubleshooting	28-33
10.1 Error Display	28
10.2 Troubleshooting	28-33

# 1. Precaution

## 1.1 Safety Precaution

To prevent personal injury and/or property damage, follow the instructions below.

*Failure to follow correct procedure may result in personal injury, death, and/or property damage. Before servicing unit, read this service manual.*

## 1.2 Warning

### INSTALLATION

**To reduce the risk of fire or explosion, electric shock, personal injury, death, product failure, or property damage during the installation process, read and follow the warnings listed below.**

- Do not use a defective or underrated circuit breaker. Use a dedicated circuit on this appliance.
- For electrical work, contact the dealer/seller, a qualified electrician, or an authorized service center. Do not disassemble or repair the product.
- Ground the product.
- Securely install the panel and cover of control box.
- Avoid improper wiring or installation.
- Use the correctly rated breaker and fuse.
- Do not modify or extend the power cable.
- Do not install, remove, or reinstall the unit unaccompanied.
- Be careful when unpacking and installing around exposed sharp edges, especially the casing edges and the fins on the condenser and evaporator.
- For installation, always contact the dealer or an authorized service center.
- Do not install the product on a defective installation stand.
- Be sure the installation area does not deteriorate with age to avoid the base collapsing.
- Do not let the air conditioner run for a long period of time when there is high humidity and a door or window is left open. Moisture may condense and wet or damage furniture.
- Do not pull out or damage the power cord during operation.
- Do not place anything on the power cable.
- Do not plug or unplug the power plug during operation.
- Do not touch/operate the product with wet hands.
- Do not place a heater or other appliance near the power cable.
- Do not allow water get into the electric parts.
- Do not store or use flammable gas near the product.
- Do not use the product in a confined space for a long period of time to avoid oxygen deficiency.
- If a flammable gas leaks, turn off the gas and open a window for ventilation before turning this product on. Do not use the telephone or turn switches on or off.
- If strange sounds or smoke come from product, turn the breaker off or disconnect from power

supply.

- Stop operation and close window during a storm. If possible, remove product from window.
- Do not open the product's inlet grill while in operation. If the unit has an electrostatic filter, do not touch it.
- Avoid having water enter the unit.
- If the product becomes soaked, flooded, or submerged in water, contact an authorized service center.
- Ventilate the product from time to time when operating it near a stove or other appliance.
- Turn the main power off when cleaning or troubleshooting the product.
- If the product will not be in use for a long period of time, disconnect it from the power supply or turn off the breaker. An unintended operation may occur.
- Ensure that no one can step on or fall onto the outdoor unit.

## CAUTION

---

**To reduce the risk of injury or property damage after installing product, read and follow the warnings listed below.**

- Always check for gas (refrigerant) leakage after installing or repairing. Low refrigerant levels may cause product failure.
- Install drain hose to ensure water drains away properly. A bad connection may cause water leakage.
- Keep unit levelled when installing to avoid vibration or water leakage.
- Do not install product where noise or hot air from the outdoor unit can bother others or damage property.
- In order to avoid personal injury, use two or more people to lift and transport product.
- Do not install the product where it will be directly exposed to ocean breeze (salt spray). It may cause corrosion, which, particularly on the condenser and evaporator fins, could cause product malfunction or inefficient operation.

## OPERATIONAL

---

**To reduce the risk of fire or explosion, electric shock, personal injury, health issues, product failure, or property damage while the product is in operation, read and follow the warnings listed below.**

- Do not sit in the draft or expose skin directly to cool air for long periods of time.
- Do not use unit for other purposes, such as preserving foods, works of art, etc., not intended for this product. It is a consumer air conditioner, not a refrigerating system.
- Do not block the inlet or outlet of airflow.
- Use a soft cloth to clean. Do not use harsh detergents, solvents, etc.
- Do not touch the metal parts of the product when removing the air filter. They are sharp.
- Always insert the filter securely. Clean the filter every two weeks or, if necessary, more since a dirty filter reduces product efficiency and could cause product malfunction or damage.
- Do not insert hands or other object through air inlet or outlet. There are sharp, moving parts inside.

- Do not drink the water drained from the product. It is unsanitary.
- Use a firm stool or ladder when cleaning the product.
- Replace all batteries in the remote control with new ones. Do not mix old and new batteries.
- Do not recharge or disassemble the batteries or dispose of them in a fire.
- If the liquid from the batteries touches exposed skin and/or gets on clothing, wash with clean water. Do not use the remote if the batteries have leaked.

## 2. Dimensions

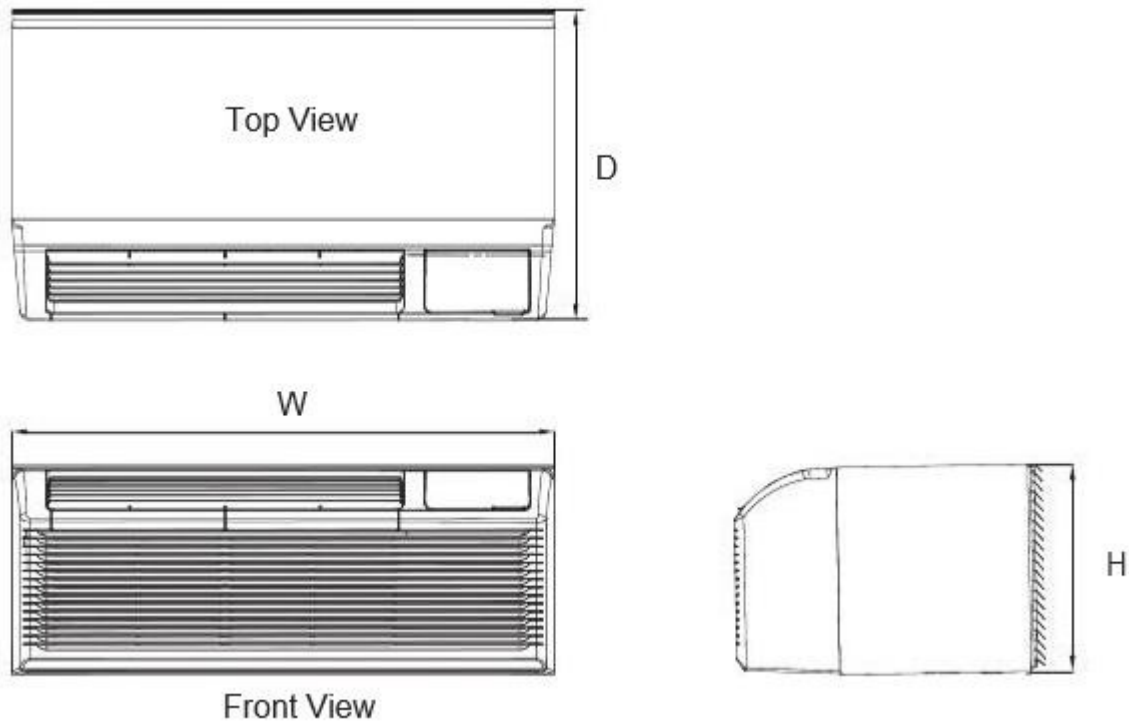

<b>Dimensions</b>	<b>W x H x D (inches)</b>
Dimension 1 No sleeve, rear grille, or rear net	42 x 15.9 x 20.9
Dimension 2 Includes sleeve with no rear grille and rear net	42 x 16 x 22.8
Dimension 3 Includes sleeve and rear net	42 x 16 x 23.1
Dimension 4 Includes sleeve, rear net, rear grille	42 x 16 x 23.9

### 3. Unit Components

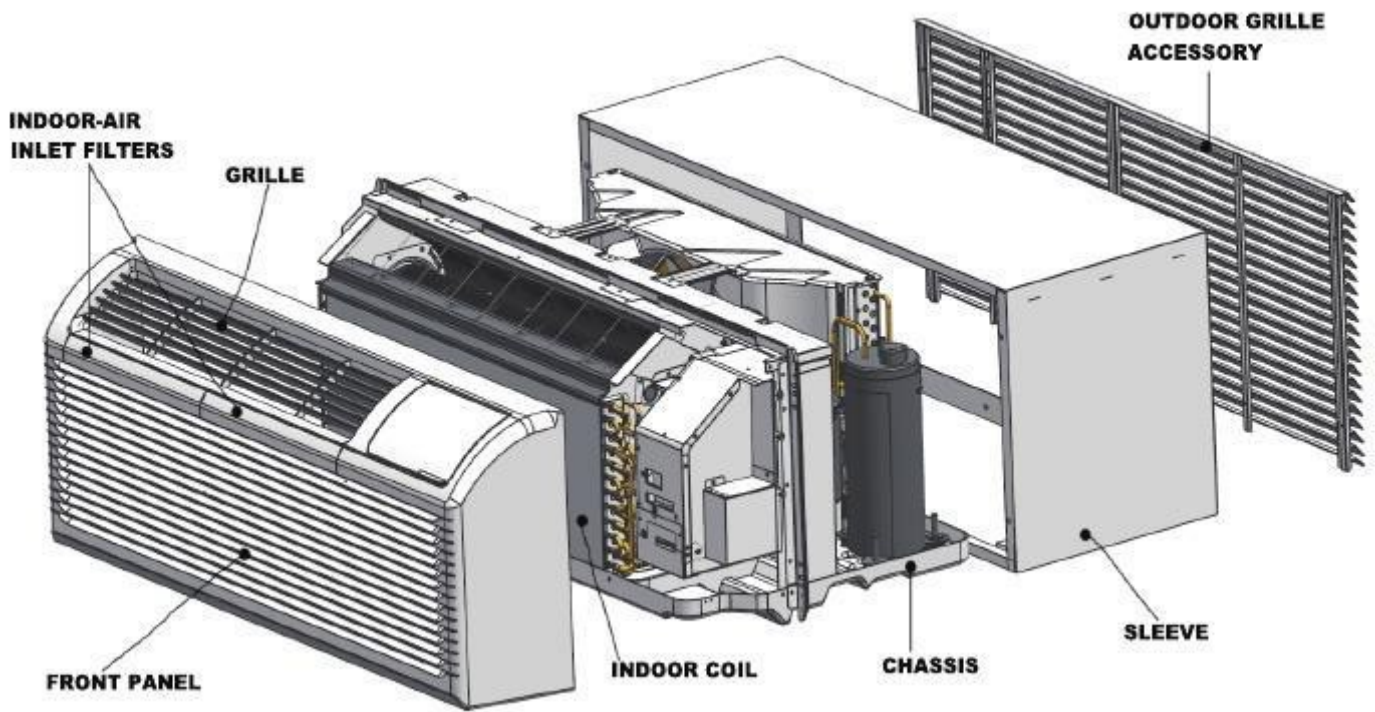

Decomposition  
Figure

## 4. Installation Details

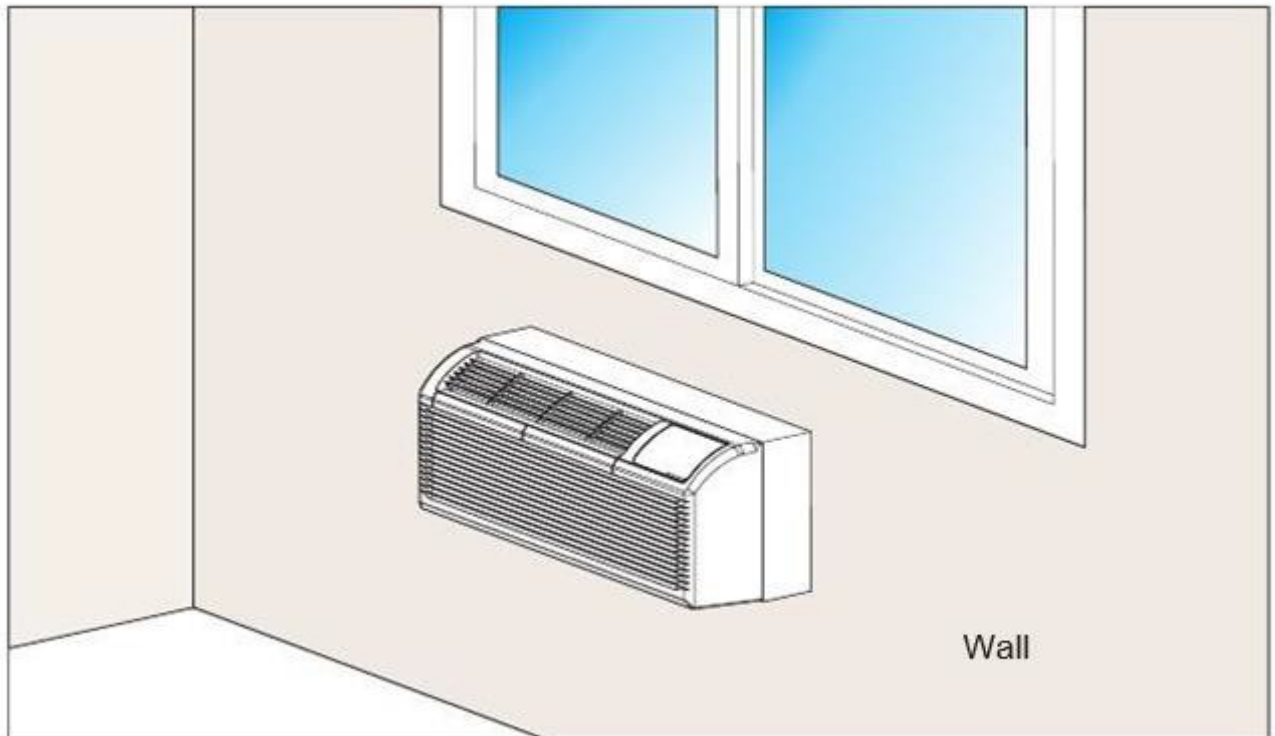

Installation (Fig. 1)

### 4.1 How to Install Unit

#### INSTALLATION



#### CAUTION

**There are sharp edges that can cause serious injury.  
When lifting the air conditioner, use 2 people to lift. Unit is heavy.**

## PREPARATION OF SLEEVE ASSEMBLY (optional)

- For an existing sleeve, measure the wall sleeve dimensions.
- Install the new air conditioner according to these installation instructions to achieve the best performance. All wall sleeves used to mount the new air conditioner must be in good structural condition and have a rear grille that securely attaches to the sleeve or the overhang of the sleeve to secure the new air conditioner.
- To avoid vibration and noise, make sure the unit is installed securely and firmly.
- When installing the sleeve, make certain there is nothing within 20 inches of the back that would interfere with heat radiation and exhaust airflow. (See Fig. 2)

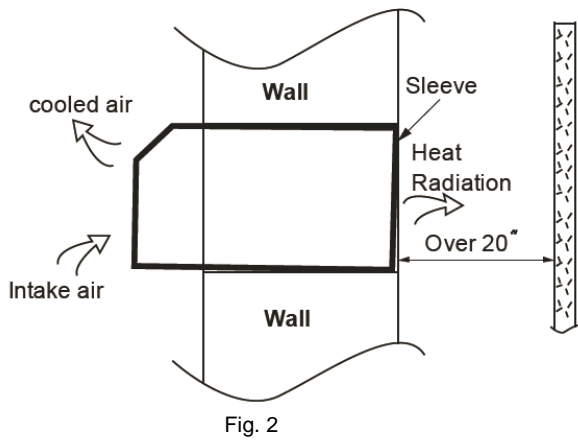

- Refer to the installation instruction of sleeve assembly for more details.

## UNIT INSTALLATION

- Carefully remove shipping tapes from the front panel. (See Fig. 3)
- Remove the front panel (see Fig. 4) by pulling out the bottom to release the tabs (A). Then lift up (B).
- Remove the shipping screw from the vent door. (See Fig. 5)
- Rotate the vent control lever to either open or close the vent door. (See Fig. 6)

## Dimensions of air conditioner

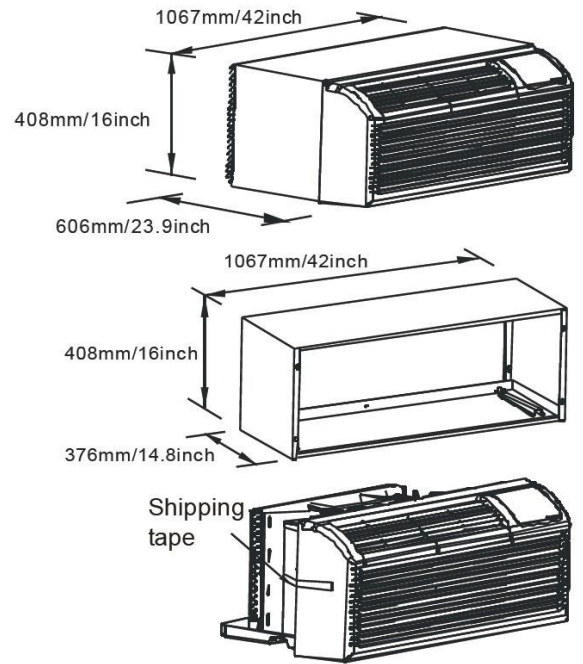

Fig.3

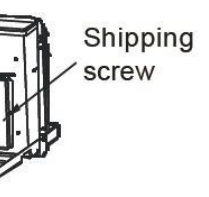
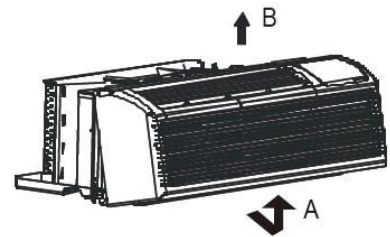
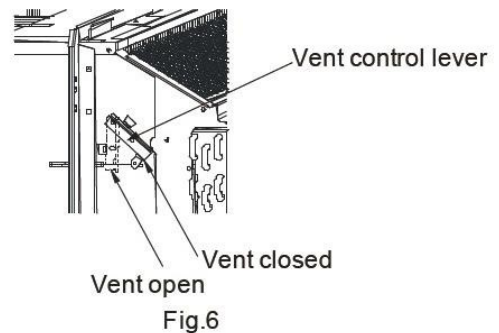

Fig.5



## UNIT INSTALLATION (CONTINUED)

- Keep unit levelled when lifting and sliding it into wall sleeve. Once it is firmly against front of wall sleeve, secure with 4 screws and washers (supplied in the Sleeve Assembly) through the unit overhang holes. (See Fig. 7 and Fig. 8)
- Reinstall front panel. (See Fig. 9) Place tabs over top rail (A). Push inward at bottom until panel snaps into place (B).
- If unit is installed where condensation drainage can drip in an undesirable location, an accessory drain kit should be installed and connected to drain system.

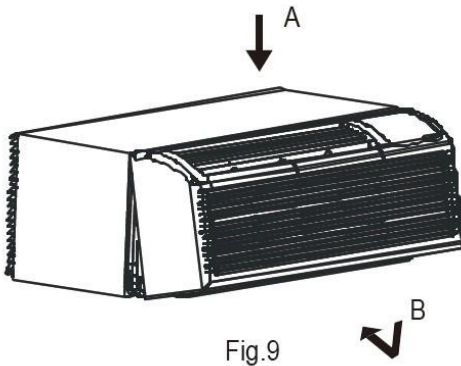

Fig.9

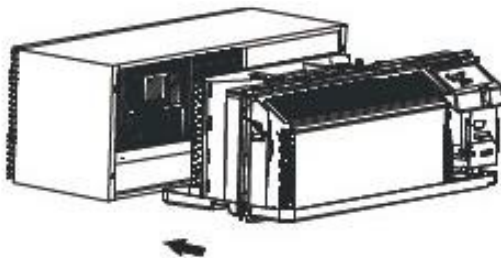

Fig.7

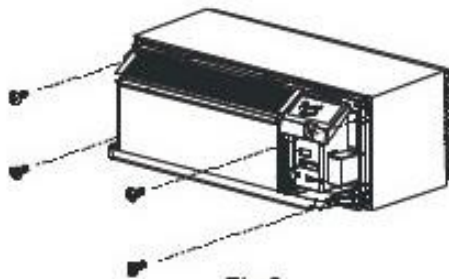

Fig.8

## 4.2 Care and Cleaning

### FRONT PANEL AND CASE

Turn unit off and disconnect from power supply. To clean, use water and a mild detergent. Do not use bleach or abrasive materials. Some commercial cleaners may damage the plastic parts.

### OUTDOOR COIL

Coil on outdoor side of unit should be checked regularly. Unit will need to be removed to inspect dirt build-up that will occur on the inside of the coil. If clogged with dirt or soot, coil should be professionally cleaned. Clean inside and outside of outdoor coils regularly.

NOTE: Never use a high-pressure spray on coil.



### CAUTION

Do not put obstacles, such as window curtain, etc., around air inlet or inside of air outlet.

Always insert the filter securely, clean filter once every two week as required.

- Removing Air Filter

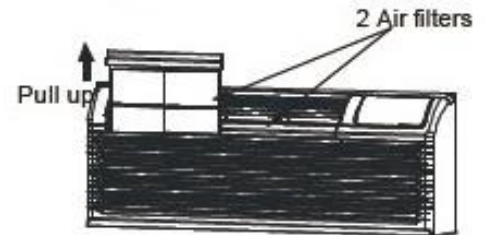

Fig.10

- Replacing Air Filter

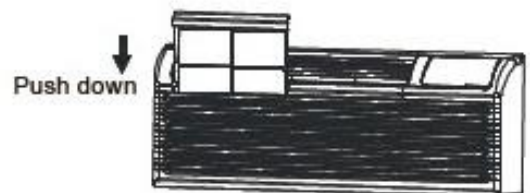

Fig.11



## CAUTION

### UNIT DAMAGE HAZARD

Failure to follow this caution may result in equipment damage or improper operation.

Airflow restriction may cause damage to the unit.

- The most important thing to do in order to maintain unit efficiency is to clean the filters once every two weeks as required.
- Clogged filters reduce cooling, heating and airflow.
- Keeping filters clean will:
  - Decrease cost of operation,
  - Save energy,
  - Prevent clogged indoor coil, and
  - Reduce risk of premature component failure.



## CAUTION

### UNIT DAMAGE HAZARD

Failure to follow this caution may result in equipment damage or improper operation.

Do not operate unit without filters in place. If a filter becomes torn or damaged, it should be replaced immediately.

Operating without filters or with damaged ones will allow dirt and dust to reach indoor coil and will reduce cooling, heating, airflow, and efficiency of unit. Airflow restriction may cause damage to unit.

## VENT DOOR FILTER

**IMPORTANT:** Turn unit off before cleaning

- If the vent door is open, gaining access requires removing the unit from the wall sleeve. Clean the vent filter twice a year or as required.
- Make sure to remove the shipping screw from the vent door. (See Fig.5)
- Rotate the vent control lever to open the vent door. (See Fig.6)
- Remove the four screws from the vent door filter. (See Fig.12)
- Pull out the vent door steel wire from the hole of the vent door, then take off the vent door and filter. (See Fig.12)
- Clean the filter. Dry thoroughly before replacing.
- Replace the vent door, reinstall the four screws.
- Reinsert the vent door steel wire.

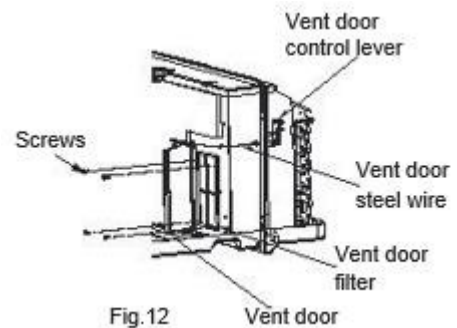

- To clean air filters:
  - Vacuum off heavy soil,
  - Run water through filter, and
  - Dry thoroughly before replacing.

# 4.3 Other Installations

Optional Wired/Wireless Digital Wall Stat and EMS systems.

## DIP SWITCH

## 24V WIRED CONTROL

Digital Wired/Wireless Wall Stat Terminal

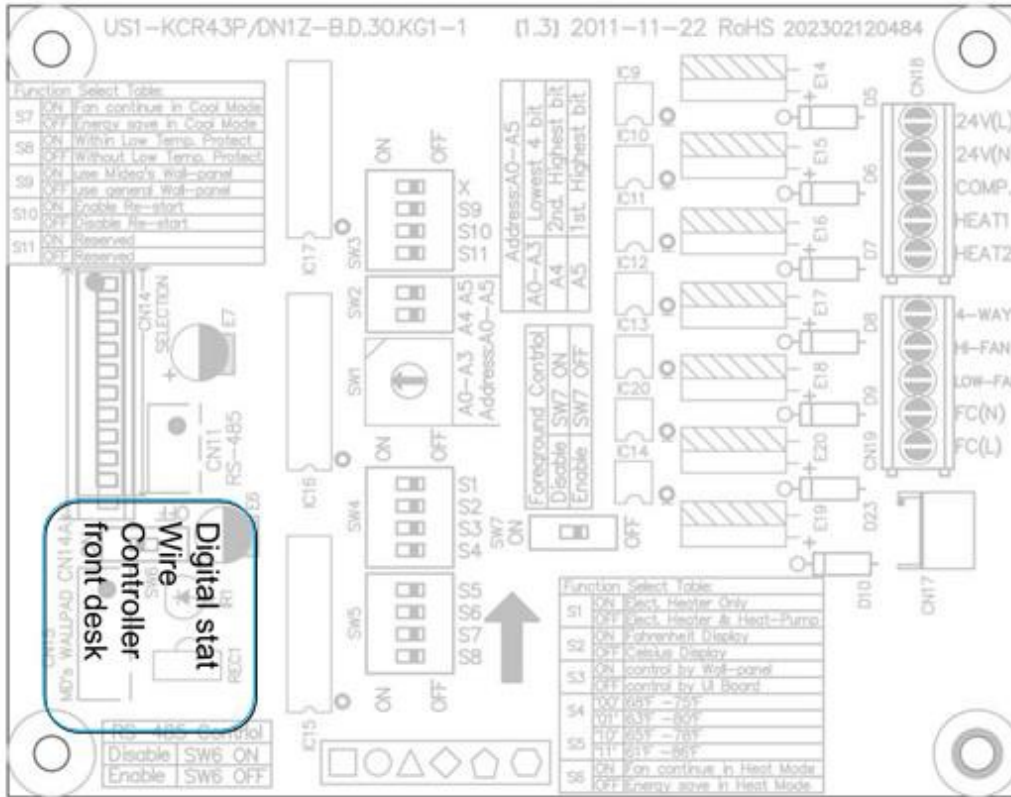
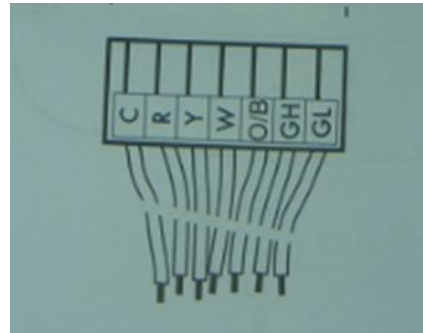
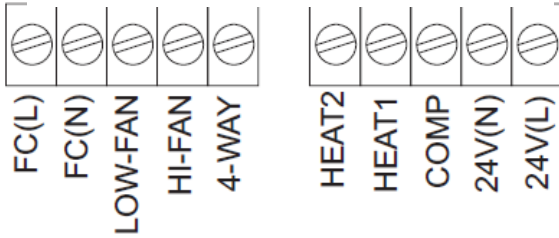

24 V controller

Front desk

## Thermostat Installation

To install wired thermostat, plug it in directly to the unit as shown below:

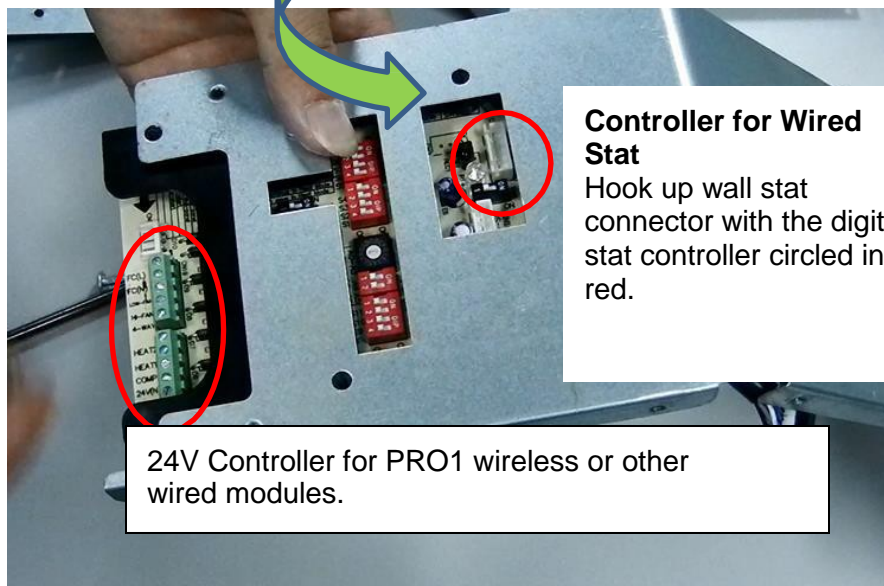

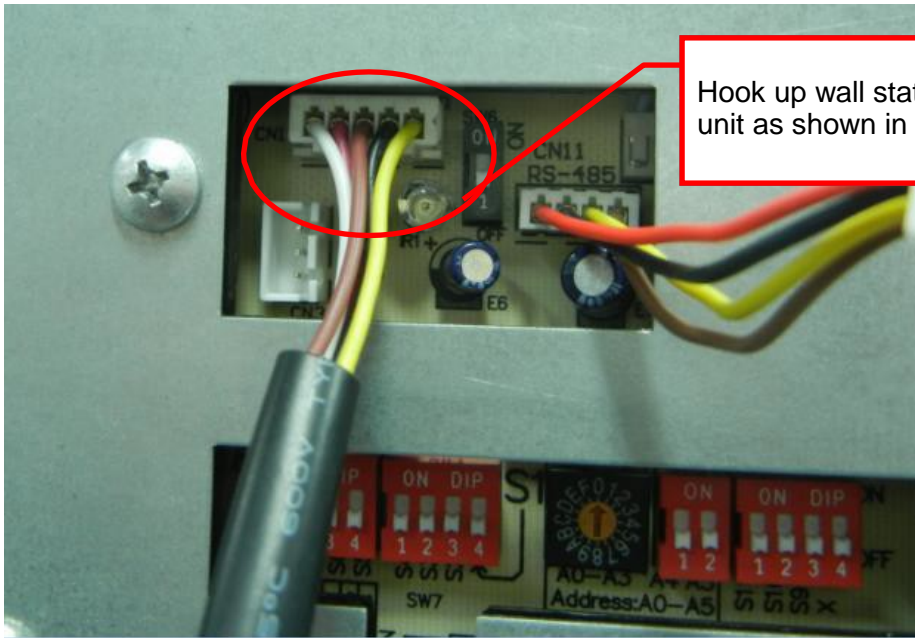

Hook up wall stat connector to the unit as shown in the image.

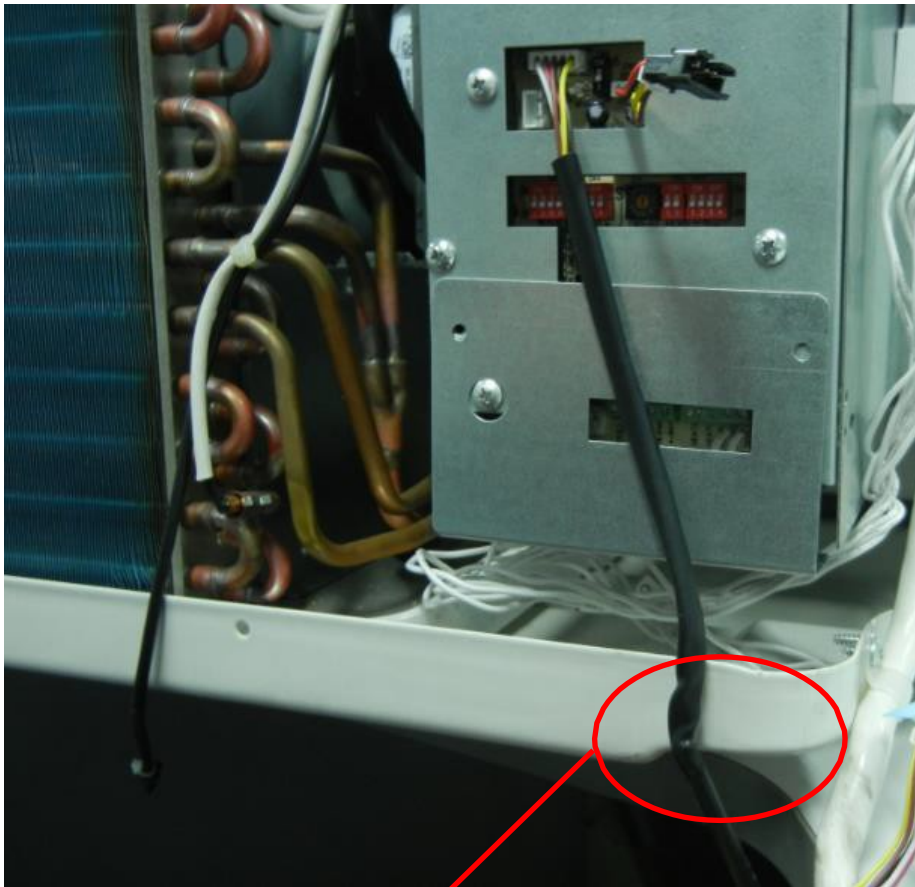

It is advisable to affix wall stat wire with tape to avoid any damage while installing the unit.

## PRO1 Wireless and Wired Digital Wall Stat Configuration

Follow the steps below:

1. Power **OFF** the unit.
2. Turn **OFF** all the DIP switches by pushing them down.
3. Turn **ON** S3—the second switch on the second block from right—by pushing it up. Circled in red below.



4. Detach the controller cover.





5. Connect the wireless or wired module with controller. Use the table below as guidance.

Unit

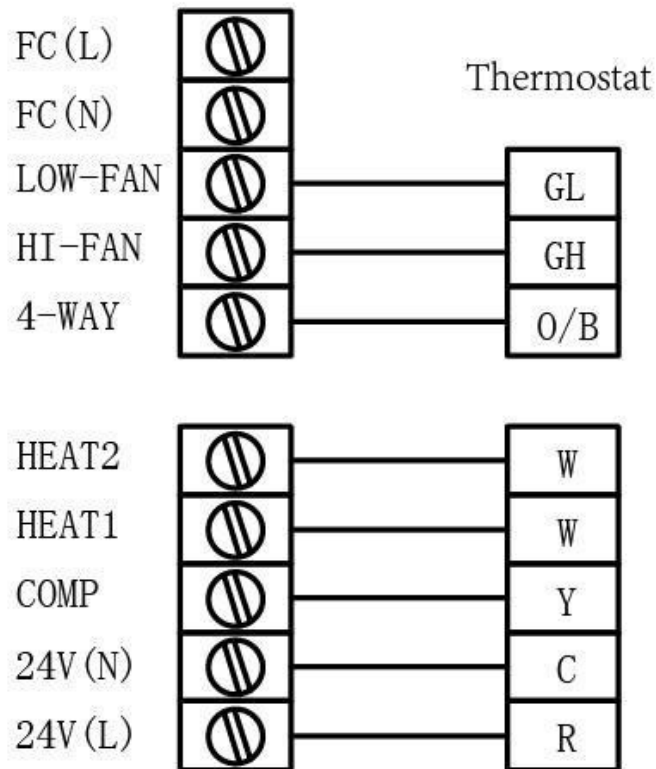

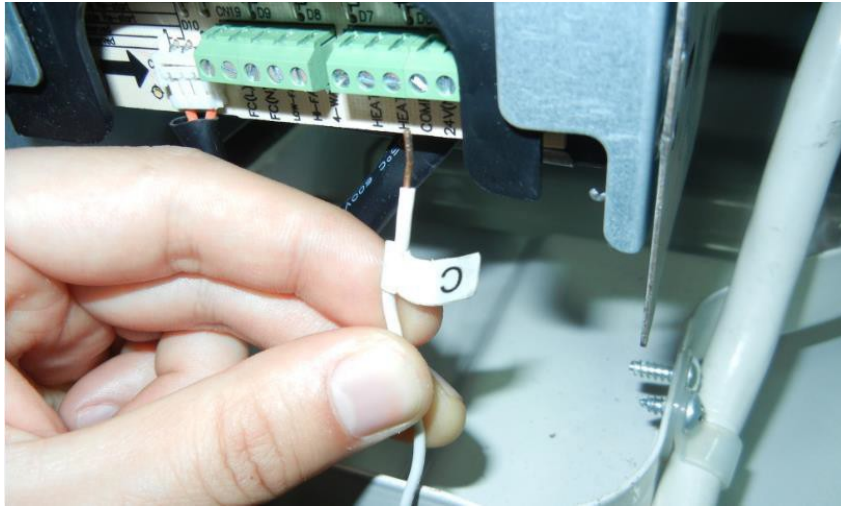

6. Jump the connection between Heat 1 and Heat 2 as shown below.

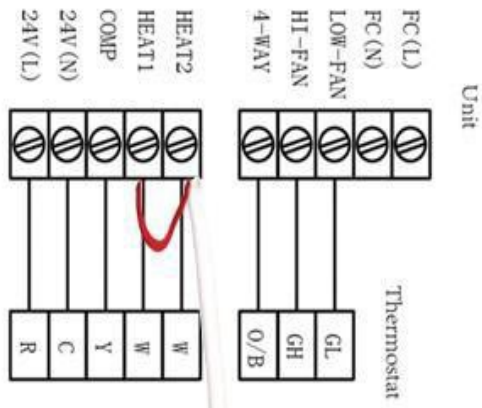

7. After connecting the stat with unit, apply double-sided tape on the back of wireless module.



8. Stick the module to unit as depicted below.

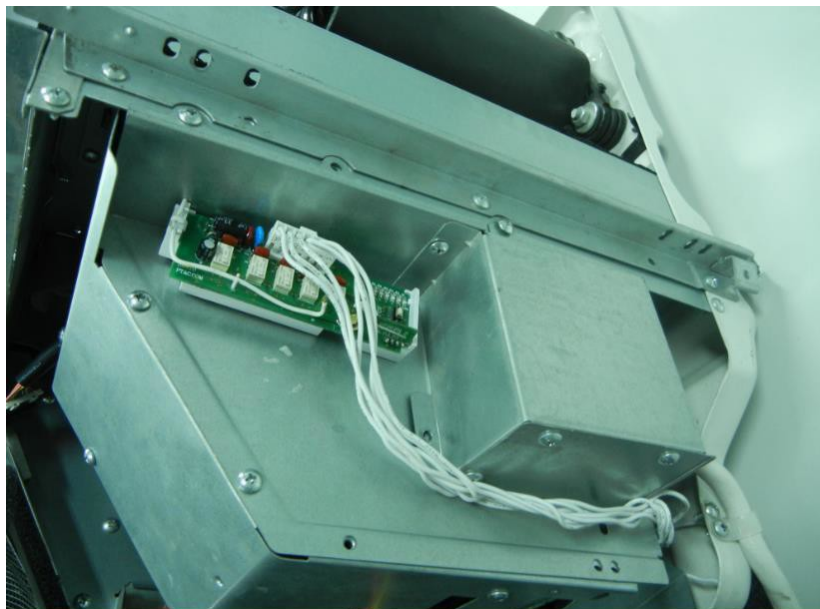

9. Set the thermostat to **OFF**.

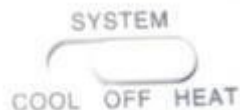

10. Set **CO** to **b** on thermostat by following the procedure below:

Press and hold **+** and **-** on thermostat until it displays **CA 1**. Then press them again to get either **CO b** or **CO 0**.

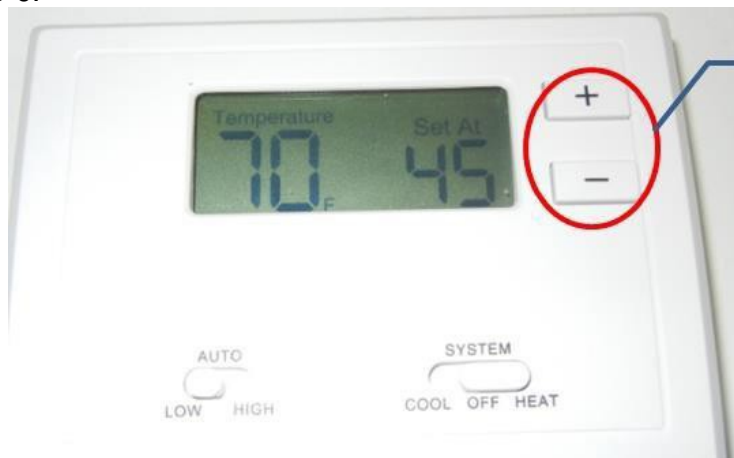

- If **CO 0** is displayed, then press **+** to change it to **CO**.
- If **CO b** is displayed, then wait for the thermostat to return to temperature screen.

11. Replace the cover and assemble the unit.

12. Turn **ON** the unit and allow 3 minutes for response time.

## 5. Functions and Control Panel

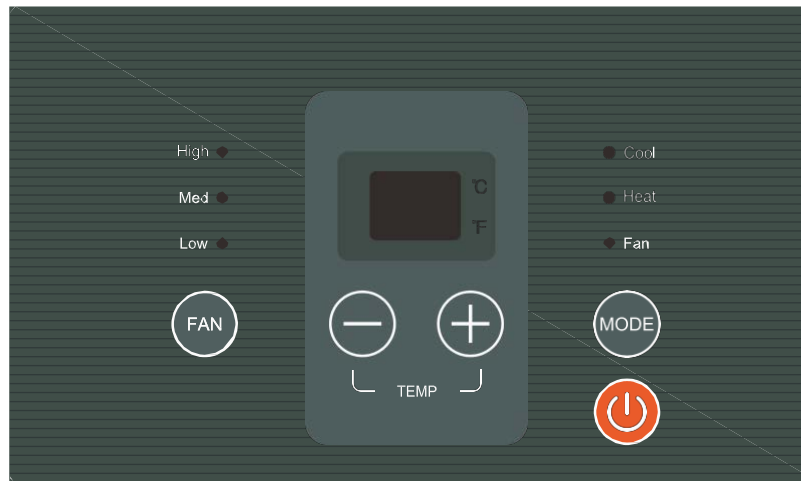

The controls featured in this manual are found in many different models. There may be slight variations.

### POWER

Press the **POWER** button to turn the unit on or off. When the unit is on, the power indicator light will be green. When the unit is off, the light will go out.

### MODE

Push this button to cycle through the modes **COOL**, **HEAT**, and **FAN**. The green indicator light beside a mode will illuminate, identifying which one is selected. The range of temperature setting is 62°F – 86°F.

- **COOL:** Cooling begins automatically when the ambient temperature is above the set point and stops when the ambient temperature is 4°F below the set point. However, the compressor will run at least 5 minutes in **COOL** mode before stopping. The fan runs in continuous mode.
- **HEAT:** For heat pump models, the unit can alternate to run between reverse cycle heat mode and electric heater mode, according to the difference between the set temperature and the ambient temperature. The fan motor cycles on and off with the compressor and electric heater.
- **FAN:** Fan operation only without heating and cooling.

**NOTE:** The reverse cycle and electric heater cannot run at the same time. It is normal for the reverse cycle heat mode not to operate in the following cases:

1. When the outdoor temperature is lower than 40°F or the ambient temperature falls 8°F below the set point temperature.
2. There is a 3-minute minimum compressor run time at any setting to prevent short cycling. The indoor fan motors start and stop before and after the compressor cycles off.
3. When frost builds up to the evaporator coils, the unit will defrost automatically and the compressor will cycle off.

### UP/DOWN BUTTONS (▲ / ▼)

Push the UP or DOWN button to increase or decrease the set temperature in cooling or heating mode. The temperature can be set by increments of 1°F. The setting temperature appears in the display.

**NOTE:** Press and hold ▲ and ▼ buttons simultaneously for 3 seconds to alternate the temperature display between °C and °F scale.

## FAN

Push this button to change the fan speed to **HIGH**, **MED**, or **LOW**.

## DISPLAY

Shows the set temperature in °C or °F. While on FAN-only mode, it shows the ambient temperature.

Control codes:

- **LC:** Pads on the control panel are not available. The unit can be set by using wire controller only.  
Note: When receiving the wired remote control signal display LC. Or when wired remote control signal is not received within the panel key operation for 5 seconds to display LC
- **FC:** Front desk control.

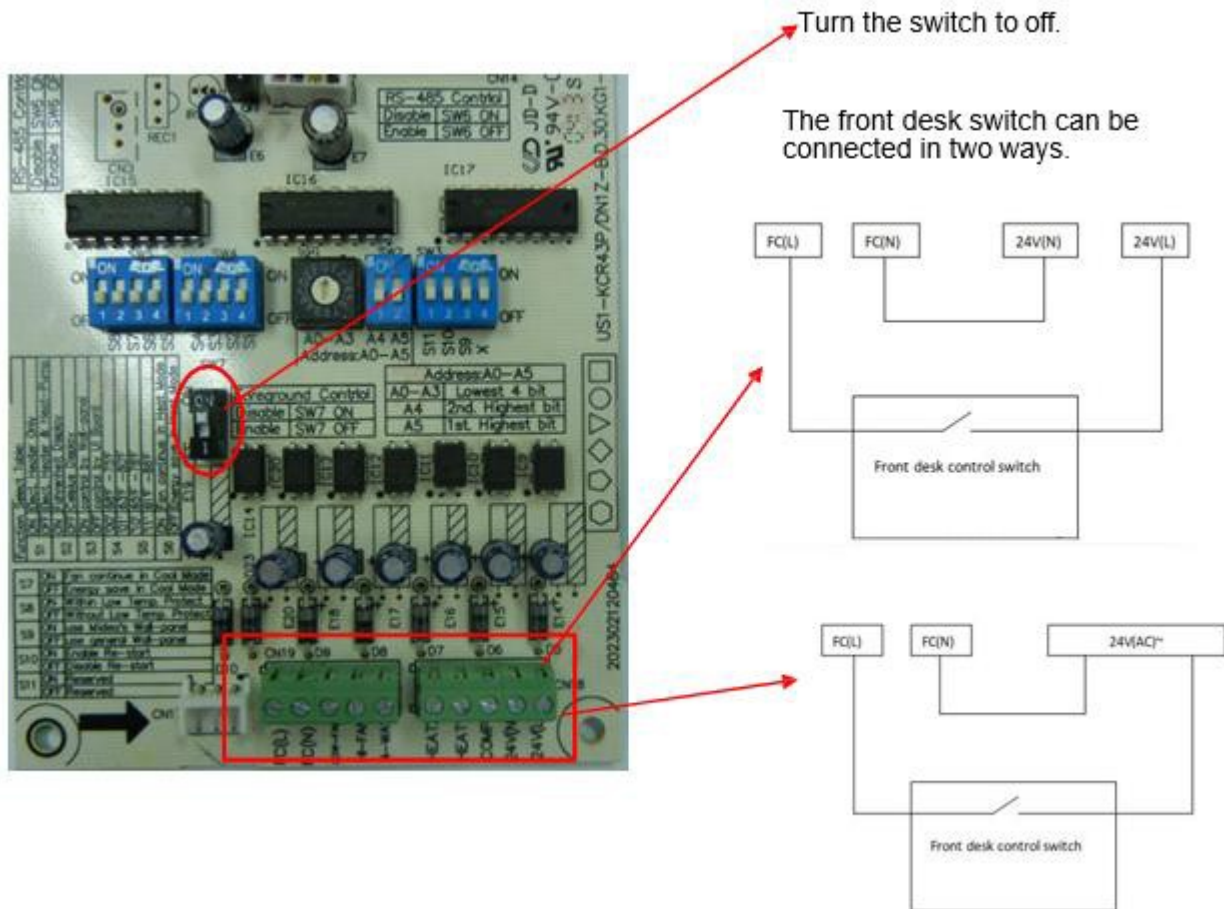

## Error codes:

- **AS:** Open or short circuit of ambient temperature sensor (T1).
- **ES:** Open or short circuit of evaporator temperature sensor (T2).
- **CS:** Open or short circuit of condenser temperature sensor (T3).
- **OS:** Open or short circuit of outside temperature sensor (T4).
- **HS:** Open or short circuit of exhaust temperature sensor (T5 or T6).

**Other codes:**

- **LO:** Room temperature is lower than 32°F.
- **HI:** Room temperature is higher than 99°F.
- **E4:** Communication failure between main control board and display board.
- **LE:** Wire Controller mode failure

**DIP Switches**

Configurations and functions of each DIP switch position are explained below.

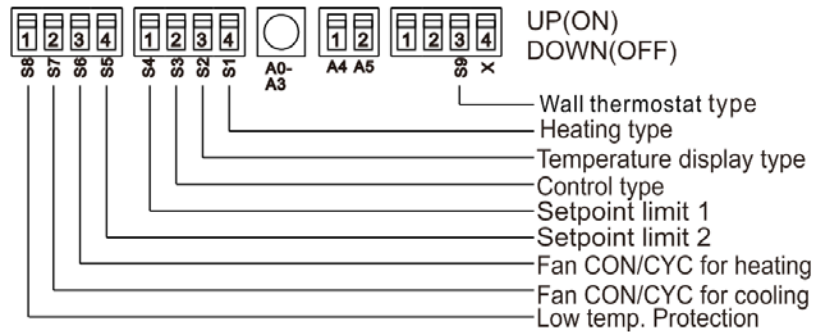
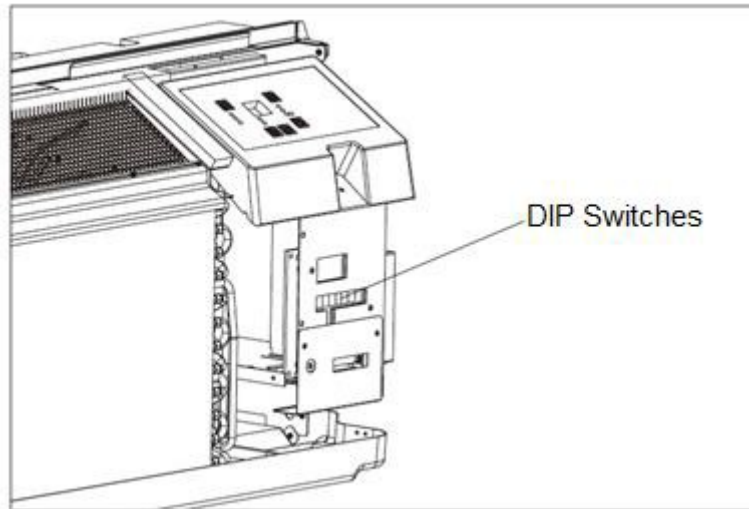

## DIP Switches Configurations

No.	UP (ON)	DOWN (OFF)	Remarks
<b>S1</b>	Electric heat only	Electric heat and pump heat	For heat pump unit only.
<b>S2</b>	Temperature Display in °C	Temperature Display in °F	
<b>S3</b>	Wall thermostat enable	Control panel enable	
<b>S4*S5</b>	UP*UP: 61°F – 86°F UP*DOWN: 65°F – 78°F DOWN*UP: 63°F – 80°F DOWN*DOWN: 68°F – 75°F		Two configurations (S4*S5) combine to select set point range.
<b>S6</b>	Fan continuous run for heating	Fan cycle for heating	
<b>S7</b>	Fan continuous run for cooling	Fan cycle for cooling	
<b>S8</b>	Low temp. protection enable	Low temp. protection disable	
<b>S9</b>	Use some types of wall thermostat	Use PTAC other wall thermostat	Consult with the sales agency or manufacturer for details.

NOTE: On heating mode, the temperature setting can't be higher than 84°F.

- **Electric Heat Only (for heat pump unit only):** This setting is typically used for emergency heating.
- **Wall Thermostat Enable:** A wired wall thermostat can be connected to the unit. To connect a wall thermostat to the unit, this DIP switch must be moved to the Wall Thermostat Enable position in order for the wall thermostat to function.
- **Set-point Temperature Limits:** Provides a restricted range of temperature control.
- **Heat and Cool Fan CON/CYC DIP switches:** Allows the fan to operate in continuous or cycle mode while the unit is in heating or cooling mode.
  - **Continuous (CON):** Allows fan to run continuously, circulating air even when the temperature setting has been satisfied. This switch helps to maintain the ambient temperature closer to the thermostat setting.
  - **Cycle (CYC):** This setting allows the fan to cycle on and off with the compressor or electric heater. The fan stops a short time after the set point is reached.

### Functions for Front desk switch panel and Wire Controller

- Front desk switch panel: If an ON/OFF switch is connected to the ports, the A/C unit can be turned off with it. The LED display on the unit will show FC.
- Wired controller: The LED display will show LC (reserved) if a wired controller is connected. If the communication portal is one way, the buttons on the control panel will be invalid.

Note: This wired controller is optional, and it is connected to the switchboard.

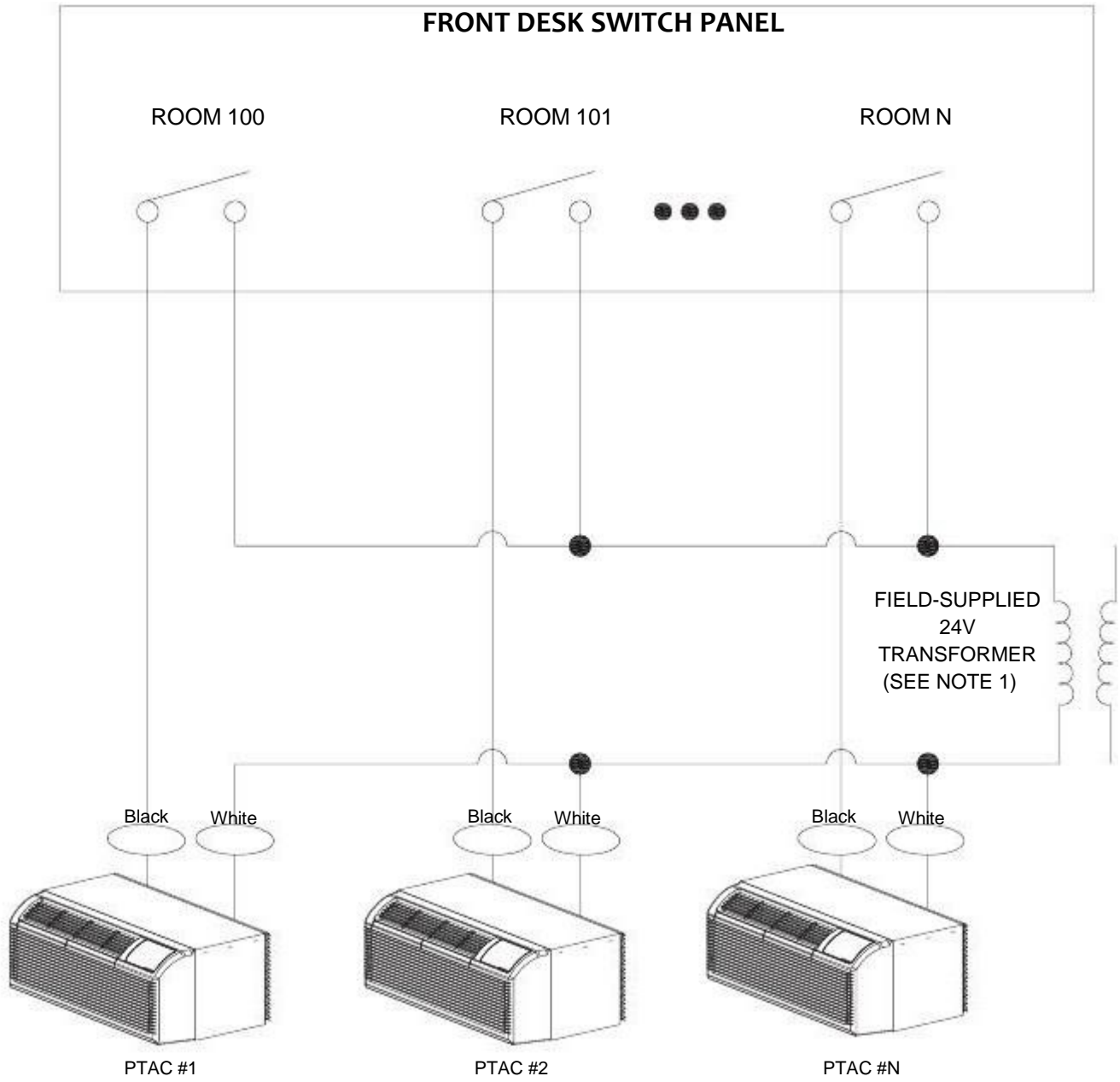

**SUGGESTIONS:**

1. To size a transformer, use the following equation:

$$\text{Quantity of PTAC units} \times 1 \text{ VA} = \text{Transformer Size (VA)}$$

Example: 110 PTAC units x 1 VA = 110 VA Transformer

2. Below are the American Wire Gauge (AWG) recommended sizes:

AWG WIRE SIZE NO.	MAX. LENGTH (FT.)
24	400
22	600
20	900
18	1500
16	2000

## 6. Refrigerant Cycle Diagram

The figure below is a brief description of the important components and their function in the refrigeration system.

This will help to explain the refrigeration cycle and the flow of the refrigerant in the Heat Pump Cycle.

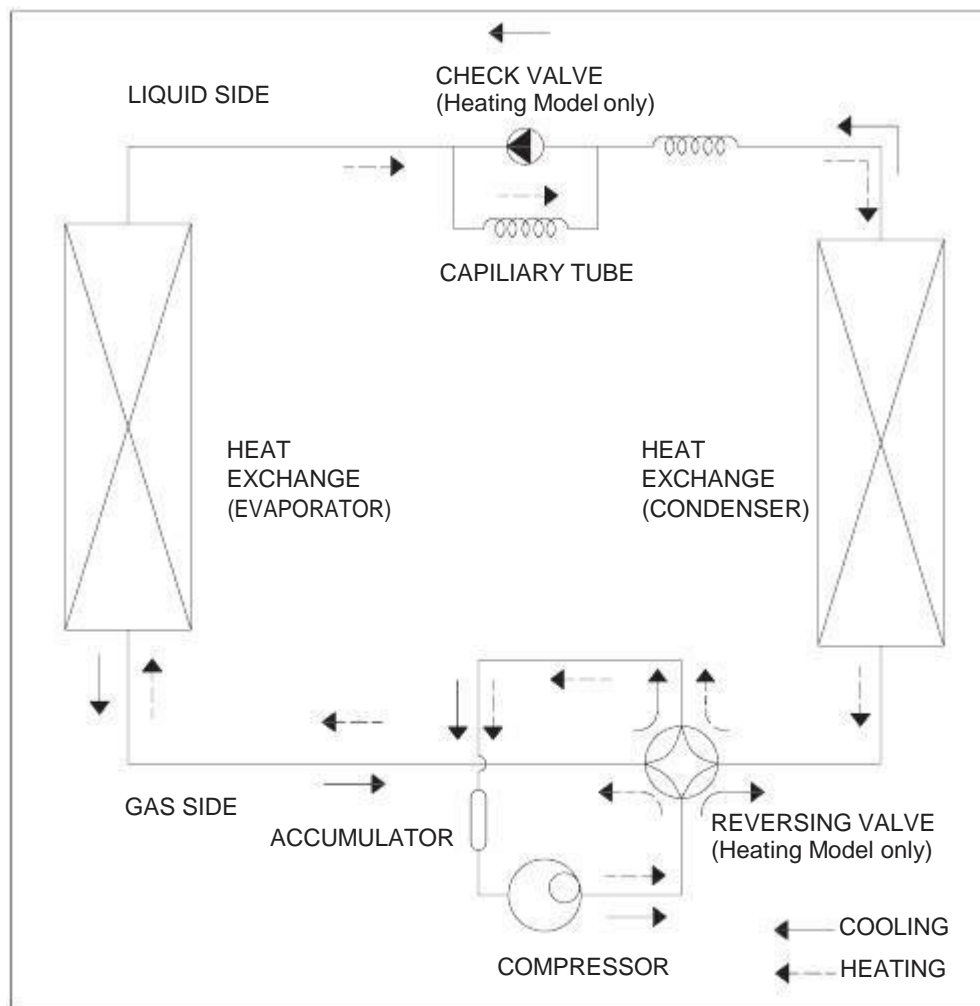

## 7. Electronic Function

### 7.1 Terms and Definitions

- **T1:** Temperature of indoor ambient.
- **T2:** Temperature of evaporator.
- **T3:** Temperature of condenser.
- **T4:** Temperature of outdoor ambient.
- **TS:** Set temperature.
- **DAT:** Discharge air temperature.
- **(T5) DAT:** Discharge air temperature (T6).

## 7.2 Electric Control Working Environment

**Input voltage:** 265V, 60Hz; 230/208V, 60Hz

## 7.3 Protection Function

- The compressor protection functions with a delay of 3 minutes.
- Sensor protection at open or short circuit of sensor.
- Evaporator anti-freezing protection in cooling mode.

## 7.4 Operation of Fan Motor

**7.4.1 Fan motor is on when compressor is on. Fan motor is off when compressor is off. (Except the T2 high Temp. protection.)**

If there is only one speed for the fan motor, use the high speed instead of the low speed.

**7.4.2 The fan motor operating in cooling only mode (see Fig. A).**

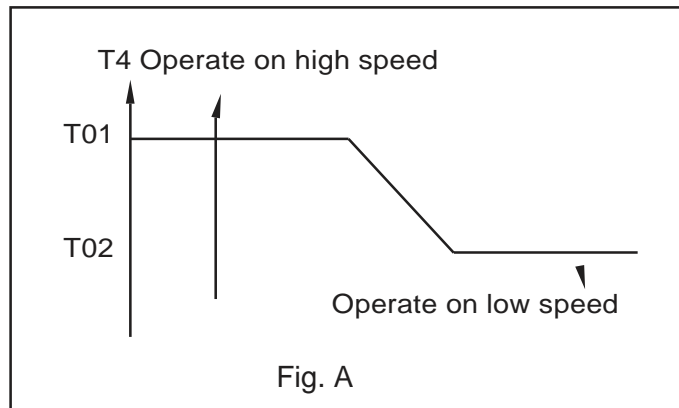

- If  $T4 > T01$  and lasts for 1 minute, the fan motor will operate at high speed.
- If  $T4 < T02$  and lasts for 1 minute, the fan motor will operate at low speed.
- If  $T02 \leq T4 \leq T01$ :
  - If fan motor was initially off, it will operate at high speed.
  - If fan motor was initially on, it will keep operating at initial speed.

### 7.4.3 The fan motor operating in heat pump and cooling mode (see Fig. B).

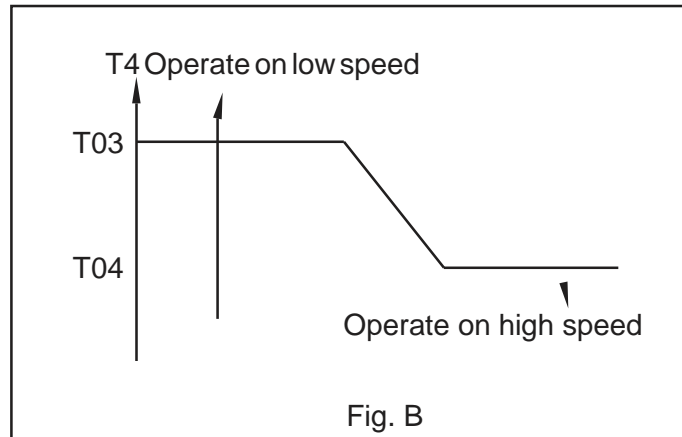

- If  $T4 \geq T03$  and lasts for 1 minute, the fan motor will operate at low speed.
- If  $T4 \leq T04$  and lasts for 1 minute, the fan motor will operate at high speed.
- If  $T04 < T4 < T03$ :
  - If fan motor was initially off, it will operate at high speed.
  - If fan motor was initially on, it will keep operating at initial speed.

### 7.4.4 The high temperature protection of evaporator at heat pump and cooling mode.

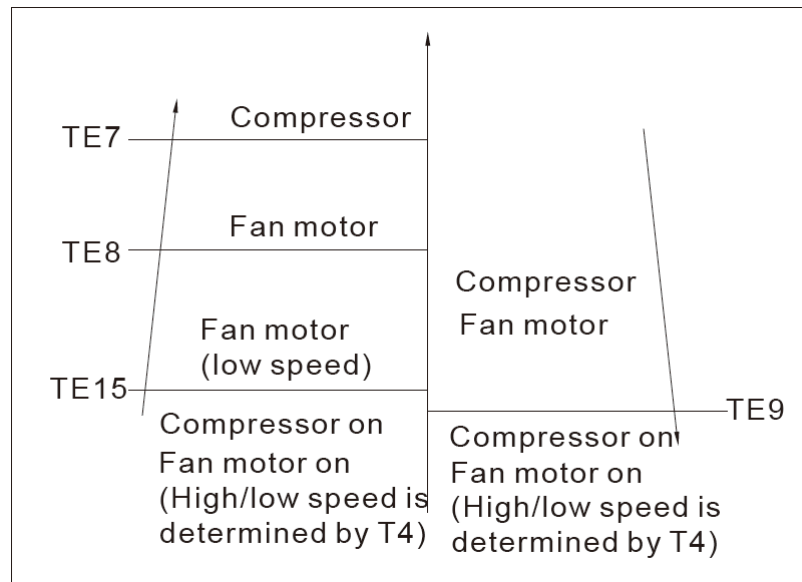

- If  $T2 > TE7$ , the unit will turn the protection of compressor off, and stop this protection when  $T2 \leq TE9$ .
- If  $T2 > TE8$ , it will turn the protection of fan motor off, and stop this protection when  $T2 \leq TE9$ .
- If  $T2 > TE15$ , fan motor will operate at low speed by force, then stop, and determine the high or low speed according to T4.

**6.4.5 At the fan only mode, the fan will keep operating and the compressor/fan motor/heater will stop operating.**

## 7.5 Operation of Compressor

### 7.5.1 The compressor operating in cooling mode.

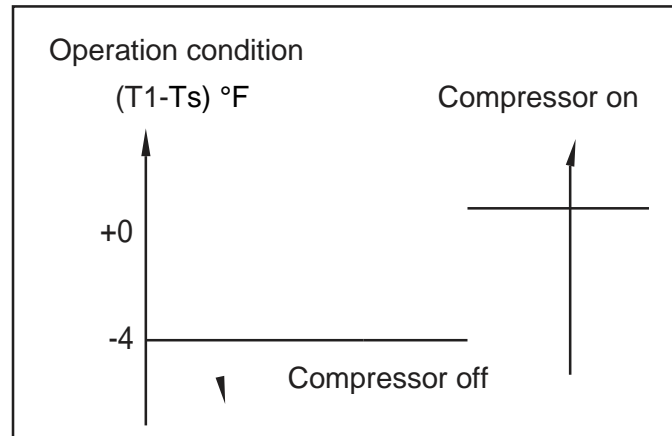

$T1 \geq T_s$  compressor is on  
 $T1 \leq T_s - 4^\circ\text{F}$  compressor is off

### 7.5.2 The compressor operating at heating mode.

There are two heating modes: (1) heat pump and (2) electric heater. The electrical heater or compressor will activate by sensing difference between set point and ambient temperature.

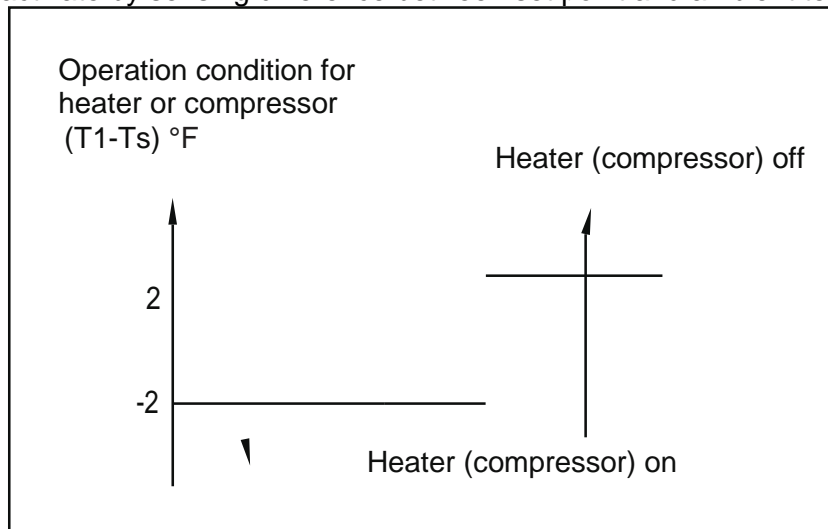

#### 7.5.2.1 The electric heater operation.

- If  $T1 < 2^\circ\text{F}$  less than  $T_s$  and the fan motor is operating, 3 seconds later the heater will turn on and operate at low speed. After 30 seconds, it will change to the set speed. If the DAT temperature is higher than the protection temperature when the heater is operating, the fan motor will turn off automatically.
- If  $T1 \geq 2^\circ\text{F}$  more than  $T_s$  and the heater is off, and the fan motor will continue working at set speed. If the DAT temperature is lower than the protection temperature and the fan motor has been operating for more than 15 seconds, then the fan motor will turn off. If the T2 protection is triggered, the fan motor will not turn on.

### 7.5.2.2 The heat pump operation.

The heat pump's operation mode correlates to whether the compressor is operating. When the compressor is on and the electric heater is off, the fan motor will operate according to the anti-cold wind of heat pump. The four-way valve is always on. If  $T_1 < T_s - 2^\circ\text{F}$ , the compressor is on. If  $T_1 \geq T_s + 2^\circ\text{F}$ , the compressor will be off. The fan motor also works in correlation to whether the compressor is in operation. If  $T_2 > T_{E7}$ , the compressor will turn off. When the DAT protection is triggered, it will prevent the compressor from operating.

## 7.6 DIP Switches and Jumper Selection

Note: This switchboard is optional.

## 8. Operation Characteristics

### 8.1 Cooling Operation

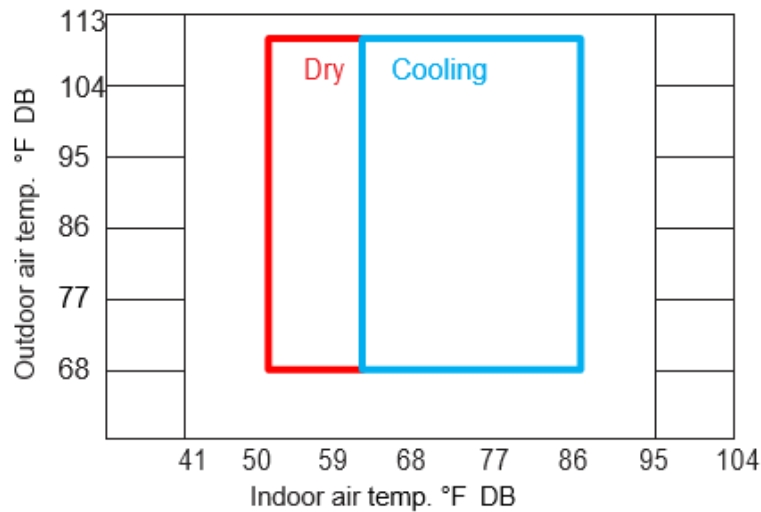

### 8.2 Heating Operation

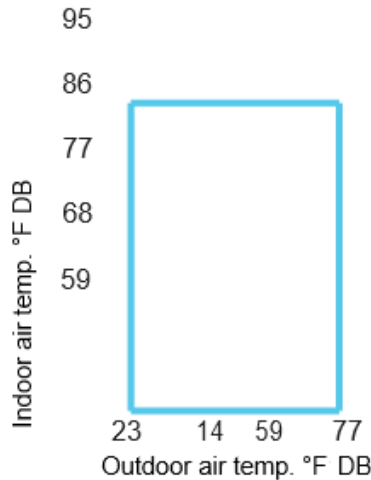

## 9. Power Connection Options

Appropriate power cord accessory kit is determined by the voltage and amperage of the branch circuit. The unit does not come with a power cord (or hardwire kit). An accessory power cord must be ordered to connect the unit to an outlet. If the unit is to be hardwired, an accessory hardwire kit must be ordered.

NOTE: For 265V units, if a power cord is selected, it must plug into the 265V subbase accessory.







### Cord-connected Units

The 240V field supplied outlet must match the plug for the standard 208/230V units and be within reach of the service cord. The standard cord-connected 265V units require an accessory electrical subbase for operation.

### Power Cord Protection

The power cord for 230/208v units provide power cord fire protection. The unit's power automatically disconnects when unsafe conditions are detected. Power to the unit can be restored by pressing the reset button on plug. Upon completion of unit installation for 230/208V models, an operational check should be performed using the **TEST/RESET** buttons on the plug.

NOTE: The 265V models do not incorporate this feature as they require use of the electrical subbase accessory. Our subbase accessory is being developed.

Power Plug							
Power Supply	230V, 15A	230V, 20A	230V, 30A	265V, 15A	265V, 20A	265V, 30A	120V, 15A

The appearance of the power plug will differ depending on the supplier.

## Power Connection Chart

UNIT MODEL	CODE OF POWER SUPPLY KIT			
	15A	20A	30A	
	208 / 230 V	208 / 230 V	208 / 230 V	
MWDUP-07AEN1-MK9	6-15P(15A / 240V )	6-20P(20A / 240V )		
MWDUP-07EEN1-MK9				
MWDUP-09AEN1-MK3		6-20P(20A / 240V )		
MWDUP-09EEN1-MK3				
MWDUP-12AEN1-MJ5				
MWDUP-12EEN1-MJ7				
MWDUP-15AEN1-MI6				6-30P(30A / 240V )
MWDUP-15EEN1-MI5				
			265 V	265 V
MWDUP-07AEN1-UK9		7-20P(20A / 277V )		
MWDUP-07EEN1-UK9				
MWDUP-09AEN1-UK3				
MWDUP-09EEN1-UK3				
MWDUP-12AEN1-UJ5				7-30P(30A / 277V )
MWDUP-12EEN1-UJ7				
MWDUP-15AEN1-UI6				
MWDUP-15EEN1-UI5				
	115V			
MWEUP-09EEN1-BK3	5-15P(15A / 120V )			
MWEUP-12EEN1-BJ7				

# 10. Troubleshooting

## 10.1 Error Display

Codes	Explanations
AS	Open or short circuit of T1 temperature sensor
ES	Open or short circuit of T2 temperature sensor
CS	Open or short circuit of T3 temperature sensor
OS	Open or short circuit of T4 temperature sensor
HS	Open or short circuit of T5 or T6 temperature sensor
Lo	Temperature is lower than display range (32°F)
HI	Temperature is higher than display range (99°F)
E4	Communication malfunction between main control board and display board
LE	Drive-by-wire control failure

## 10.2 Troubleshooting

### 10.2.1 Open circuit or short circuit of temperature sensor diagnosis and solution (AS/E5/CS/oS/HS).

<b>Error Code:</b>	AS/ES/CS/OS/HS
<b>Malfunctioning conditions:</b>	If the sampling voltage is lower than 0.06V or higher than 4.94V, the LED will display the failure.
<b>Possible causes:</b>	<ul style="list-style-type: none"> <li>● Wiring mistake</li> <li>● Faulty sensor</li> <li>● Faulty PCB</li> </ul>

Troubleshooting:

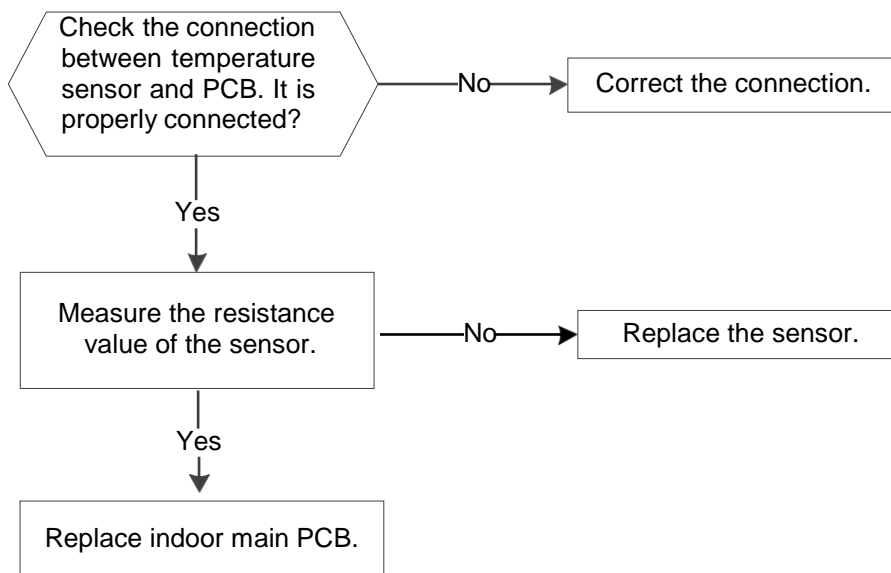

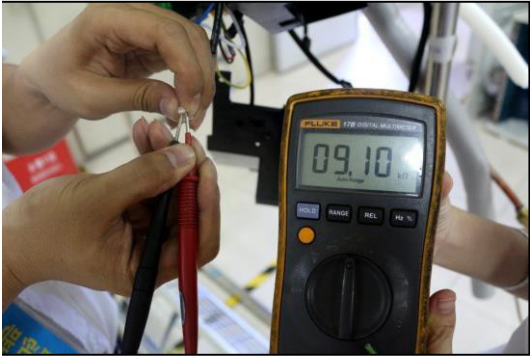
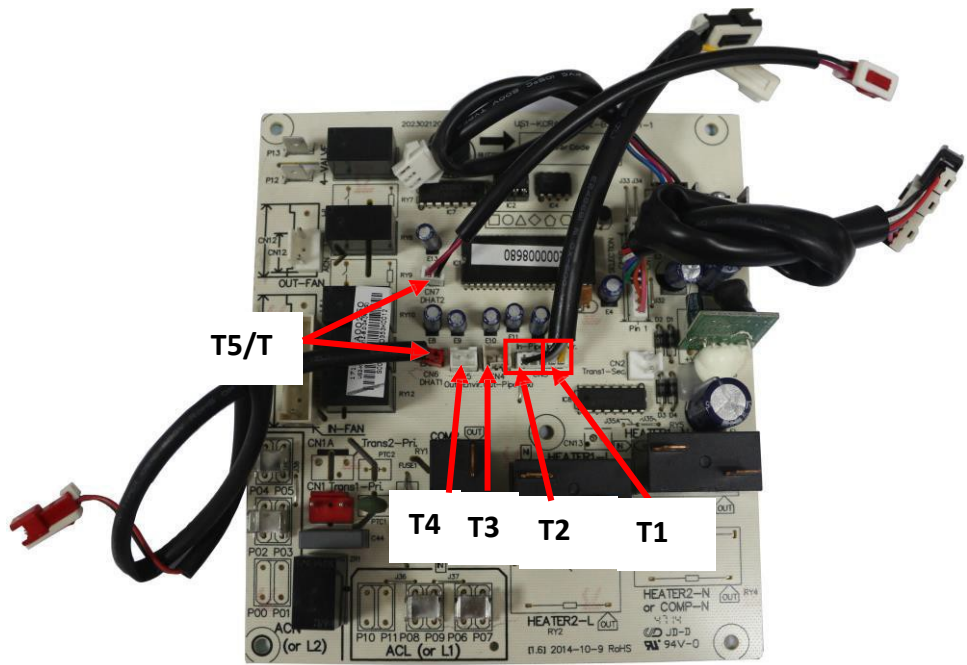

10.2.2 Communication malfunction between main control board and display board (E4).

<b>Error Code:</b>	E4
<b>Malfunctioning conditions:</b>	Main control board does not receive feedback from display board during 120 seconds.
<b>Possible causes:</b>	<ul style="list-style-type: none"> <li>● Wiring error</li> <li>● Faulty display board</li> <li>● Faulty main control board</li> </ul>

Troubleshooting:

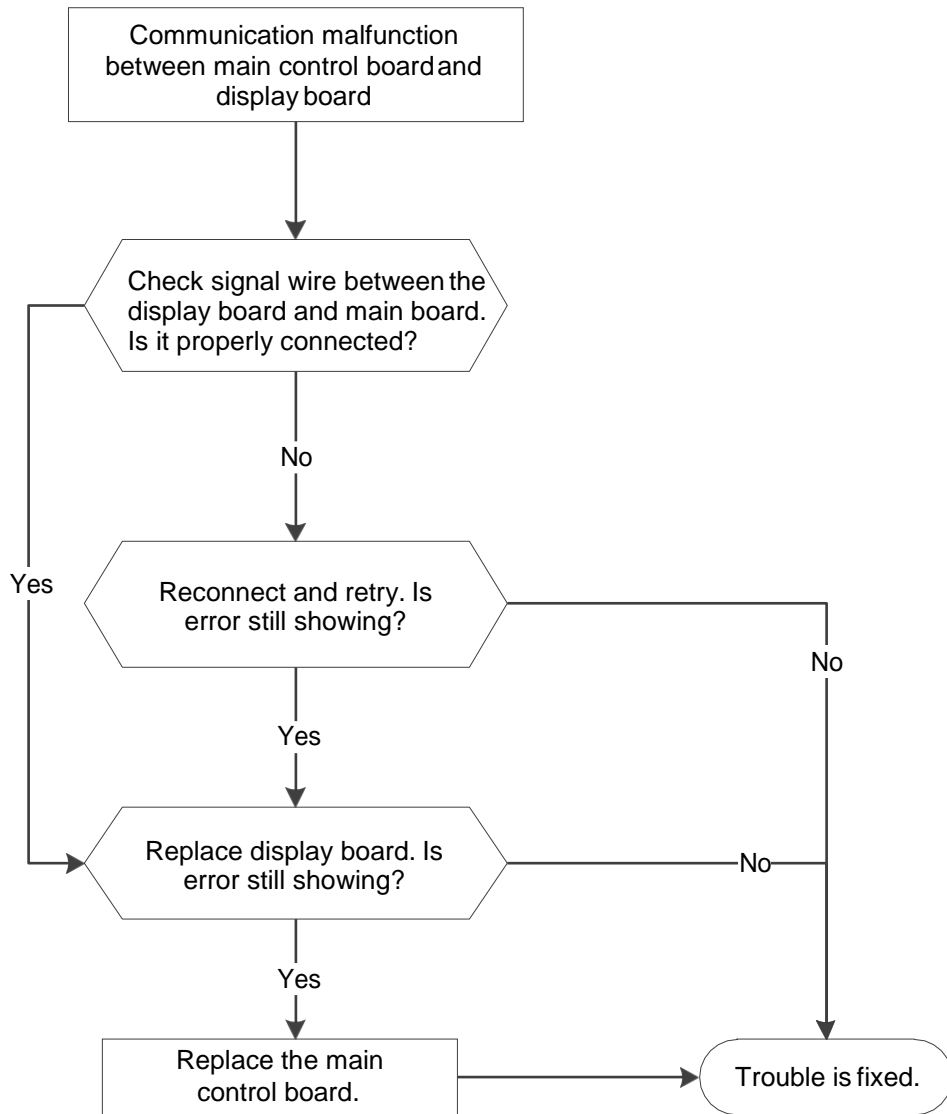

### 10.2.3 Drive-by-wire controller failure (LE).

<b>Error Code:</b>	LE
<b>Malfunctioning conditions:</b>	<ol style="list-style-type: none"> <li>1. Electric heating signal or compressor signal is on, but fan signal is off.</li> <li>2. Electric heating and compressor signals are on, but 4-way valve signal is off.</li> <li>3. Cooling only models have heating signal, or the 4-way valve and compressor signals are on at the same time.</li> </ol>
<b>Possible causes:</b>	<ul style="list-style-type: none"> <li>• Wiring error</li> <li>• Faulty wire controller</li> <li>• Wire controller doesn't match</li> </ul>

Troubleshooting:

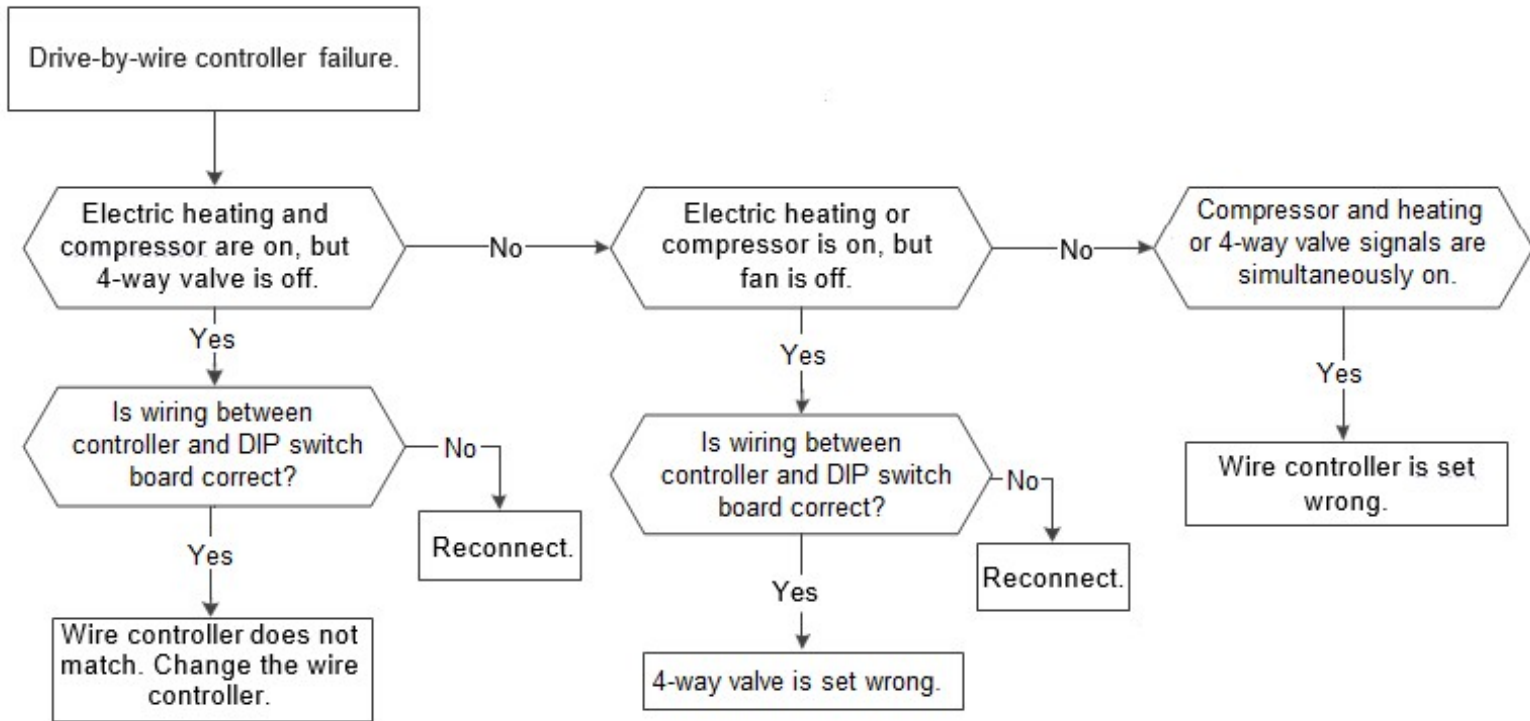

DIP Switch Terminal	Designation	24V Controller
FC(L)	Front desk control terminal L	
FC(N)	Front desk control terminal N	
LOW-FAN	Low fan speed	GL
HI-FAN	High fan speed	GH
4-WAY	4-way valve(for heat pump model)	B
HEAT2	Electrical heater 2	W
HEAT1	Electrical heater 1	(W)
COMP	Compressor	Y
24V(N)	24VAC terminal N COM	C
24V(L)	24VAC terminal L	R

Possible Causes	Solutions
<b>UNIT DOES NOT START</b> Unit is unplugged. Blown fuse. Tripped circuit breaker. Unit is turned off. Unit is in a protection mode.	Check that plug is securely connected to outlet. Note: Plug has a test/reset button on it. Make sure that the plug has not tripped. Replace fuse. See Note 1 below. Reset circuit breaker. See Note 1 below. Turn unit on (bottom right button on keypad).
<b>UNIT NOT COOLING/HEATING ROOM</b> Air discharge section is blocked. Temperature setting is not high or low enough. Note: Setpoint limits might not allow unit to heat or cool the room to the temperature desired. Check section on DIP switch settings. Air filters are dirty. Room is excessively hot or cold when unit starts. Vent door left open. Unit may be in a protection mode. Compressor is in a time delay.	Make sure curtains, blinds, and/or furniture are not restricting or blocking unit's airflow. Reset to a lower or higher temperature setting. Remove and clean filters. Allow sufficient amount of time for unit to heat or cool the room. Start heating or cooling before outdoor temperature, cooking heat, or people make room uncomfortable. Close vent door. Check DIP switch settings for desired comfort. Wait approximately 3 minutes for compressor to start.
<b>DISPLAY HAS STRANGE NUMBERS/CHARACTERS ON IT</b>	The unit may be in a protection mode. The unit may have been set for °C instead of °F.
<b>UNIT MAKING NOISES</b>	Clicking, gurgling, and whooshing noises are normal during operation.
<b>WATER DRIPPING OUTSIDE</b>	If a drain kit has not been installed, condensation runoff during hot and humid weather is normal. See Note 2 below. If a drain kit has been installed and is connected to a drain system, check gaskets and fittings around drain for leaks and plug them.
<b>WATER DRIPPING INSIDE</b> Wall sleeve is not installed properly.	Wall sleeve must be installed correctly for proper drainage of condensation. Check that installation is levelled and make any necessary adjustments.
<b>ICE OR FROST FORMS ON INDOOR COIL</b> Low outdoor temperature. Dirty filters.	When outdoor temperature is approximately 55°F or below, frost may form on the indoor coil when unit is in Cooling mode. Switch unit to <b>FAN</b> operation until ice or frost melts. Remove and clean filters.
<b>COMPRESSOR PROTECTION</b> Power may have cycled, so compressor is in a restart protection.	<b>Random Compressor Restart:</b> Whenever the unit is plugged in or power has been restarted, a random compressor restart will occur. After a power outage, the compressor will restart after approximately 3 minutes. <b>Compressor Protection:</b> To prevent short cycling of compressor, there is a random startup delay of 3 minutes and a minimum compressor run time of 3 minutes.

## NOTES

1. If circuit breaker is tripped or fuse is blown more than once, contact a qualified electrician.
2. If unit is installed where condensation drainage could drip in an undesirable location, an accessory drain kit should be installed and connected to drain system.

## Characteristics of Temperature Sensor

Temp. °C/°F	Resistance KΩ	Temp. °C/°F	Resistance KΩ	Temp. °C/°F	Resistance KΩ
-10/14	62.2756	17/62	14.6181	44/111	4.3874
-9 /15.8	58.7079	18/64	13.918	45/113	4.2126
-8 /17.6	56.3694	19/66	13.2631	46/115	4.0459
-7 /19.4	52.2438	20/68	12.6431	47/117	3.8867
-6 /21.2	49.3161	21/70	12.0561	48/118	3.7348
-5 /23	46.5725	22/72	11.5	49/120	3.5896
-4 /24.8	44	23/73	10.9731	50/122	3.451
-3 / 26.6	41.5878	24/75	10.4736	51/124	3.3185
-2 / 28.4	39.8239	25/77	10	52/126	3.1918
-1 /30.2	37.1988	26/79	9.5507	53/127	3.0707
0 /32	35.2024	27/81	9.1245	54/129	2.959
1 /33.8	33.3269	28/82	8.7198	55/131	2.8442
2 /35.6	31.5635	29/84	8.3357	56/133	2.7382
3 /37.4	29.9058	30/86	7.9708	57/135	2.6368
4 /39.2	28.3459	31/88	7.6241	58/136	2.5397
5 /41	26.8778	32/90	7.2946	59/138	2.4468
6 /42.8	25.4954	33/91	6.9814	60/140	2.3577
7 /44.6	24.1932	34/93	6.6835	61/142	2.2725
8 /46.4	22.5662	35/95	6.4002	62/144	2.1907
9 /48.2	21.8094	36/97	6.1306	63/145	2.1124
10 /50	20.7184	37/99	5.8736	64/147	2.0373
11 /51.8	19.6891	38/100	5.6296	65/149	1.9653
12 /53.6	18.7177	39/102	5.3969	66/151	1.8963
13 /55.4	17.8005	40/104	5.1752	67/153	1.830
14 /57.2	16.9341	41/106	4.9639	68/154	1.7665
15 /59	16.1156	42/108	4.7625	69/156	1.7055
16 /60.8	15.3418	43/109	4.5705	70/158	1.6469



GD Midea Air-Conditioning Equipment  
Co.,Ltd RAC Overseas Sales Company  
Midea headquarter building, No.6 Midea Avenue  
Beijiao, ShunDe, Foshan, GuangDong, P.R.C, 528311  
Website: [www.mideaircon.com](http://www.mideaircon.com)