



HERITAGE MEDIA MANTEL FOR 23 IN. FIREBOX

MODEL #23-29-65

Français p. 11

Español p. 21

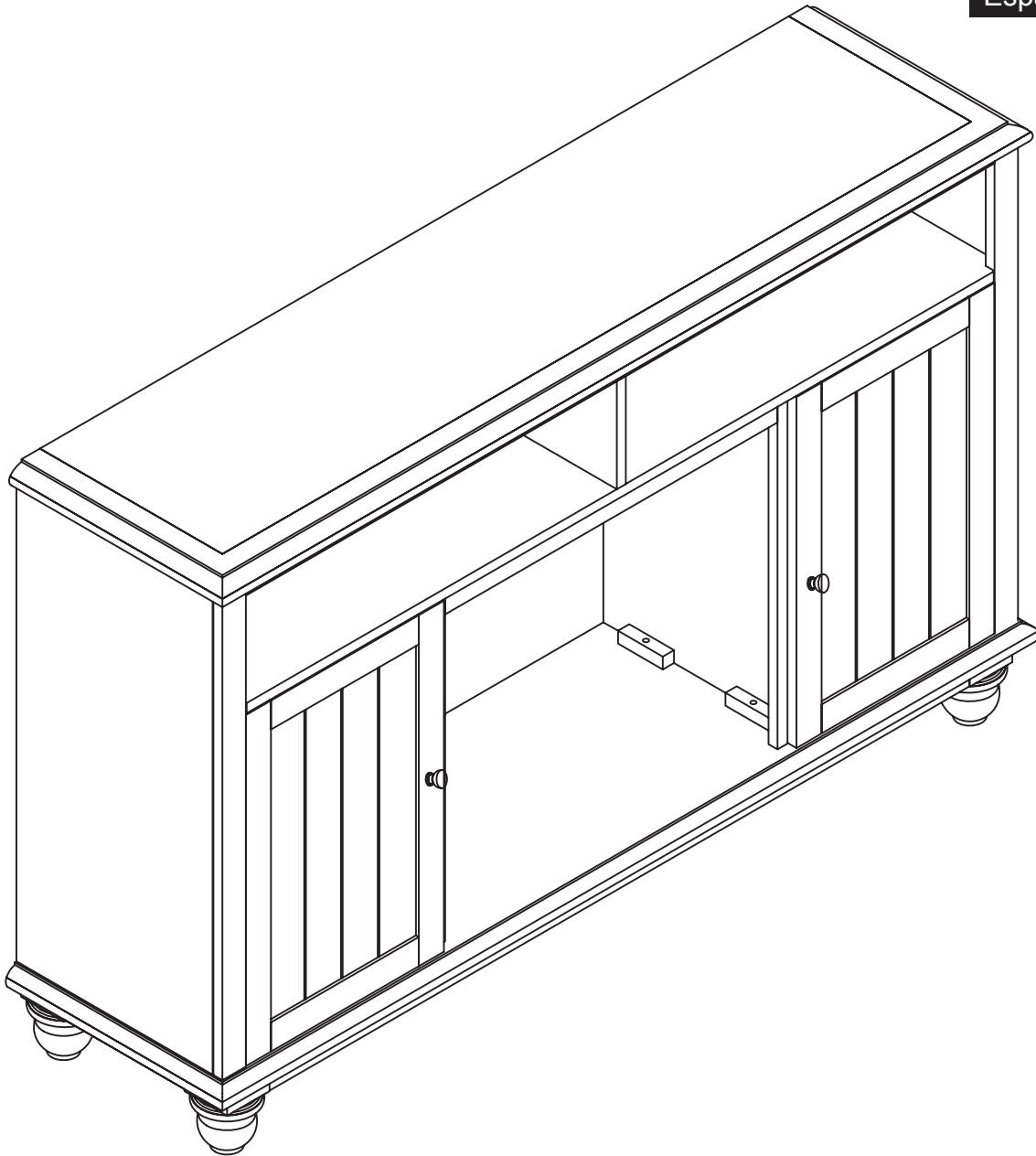

ATTACH YOUR RECEIPT HERE

Serial Number _____ Purchase Date _____







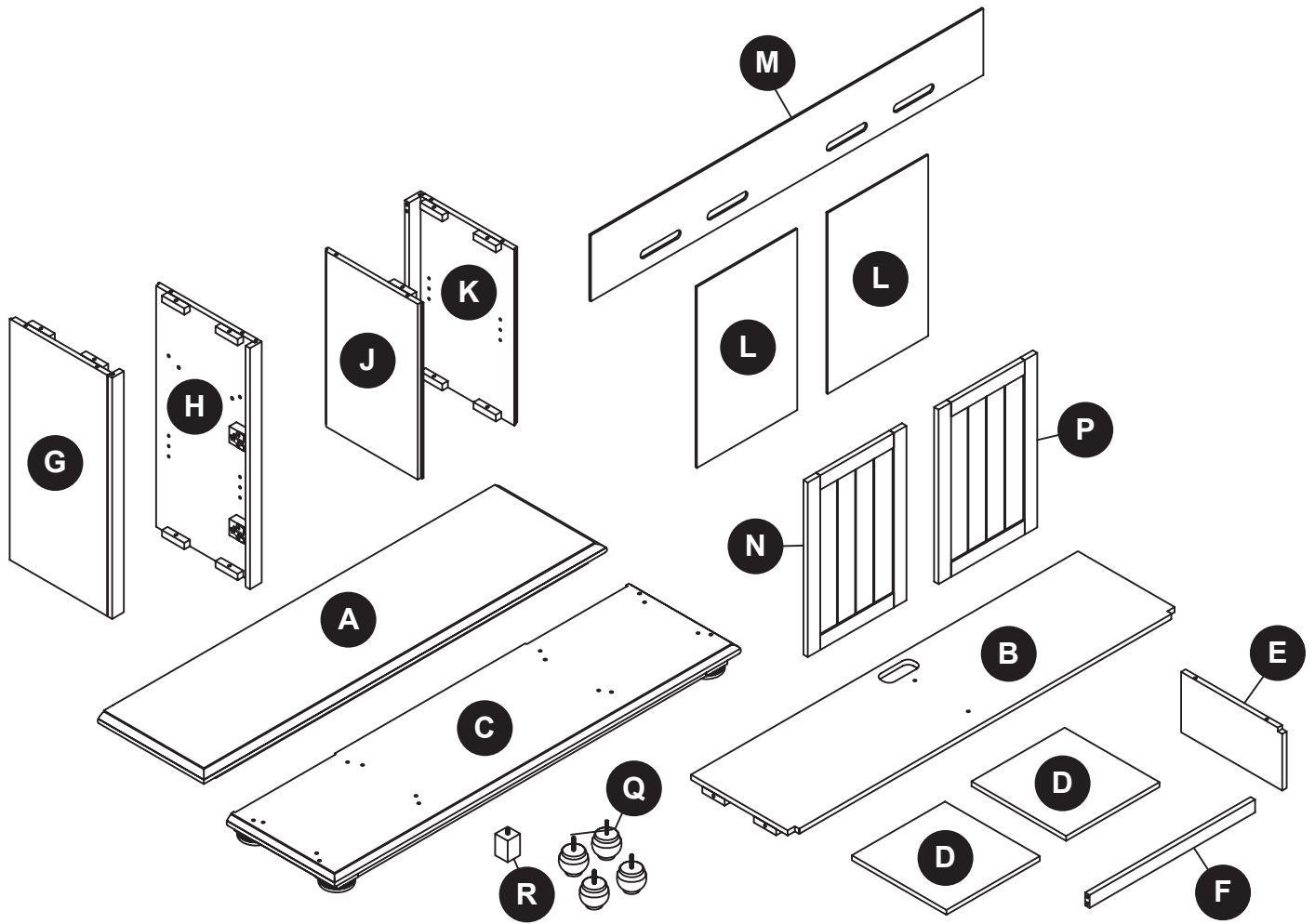

Questions, problems, missing parts? Before returning to your retailer, call our customer service department at 1-877-447-4768, 8:30 a.m. - 4:30 p.m., CST, Monday - Friday.

PACKAGE CONTENTS

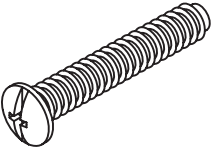
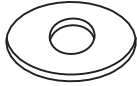

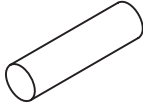
PART	DESCRIPTION	QUANTITY
A	Top Panel	1
B	Top Shelf	1
C	Base	1
D	Adjustable Shelf	2
E	Top Shelf Divider	1
F	Shelf Rail	1
G	Left Side Panel	1
H	Right Side Panel	1
J	Left Inner Panel	1
K	Right Inner Panel	1
L	Lower Back Panel	2
M	Upper Back Panel	1
N	Left Cabinet Door	1
P	Right Cabinet Door	1
Q	Leg	4
R	Middle Leg	1

HARDWARE CONTENTS (shown actual size)

AA	BB	CC	DD	EE	FF	GG	HH
							
Bolt	Flat Washer	Lock Washer	Dowel	Screw	Knob Screw	Cabinet Door Knob	Shelf Support
Qty. 20	Qty. 20	Qty. 20	Qty. 28	Qty. 42	Qty. 2	Qty. 2	Qty. 8

SAFETY INFORMATION

Please read and understand this entire manual before attempting to assemble, operate or install the product.

WARNING

- Mantel is heavy and should be assembled near its desired location.
- It is recommended that two people move the finished mantel to prevent injury.

PREPARATION

Before beginning assembly of product, make sure all parts are present. Compare parts with package contents list and hardware contents list. If any part is missing or damaged, do not attempt to assemble the product.

Estimated Assembly Time: 45 minutes

Tools Required for Assembly: Phillips screwdriver (not included).

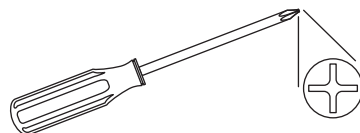

ASSEMBLY INSTRUCTIONS

1. Screw each of the four legs (Q) into the predrilled holes in each corner of the base (C). Screw middle leg (R) into predrilled hole in center brace of base (C).

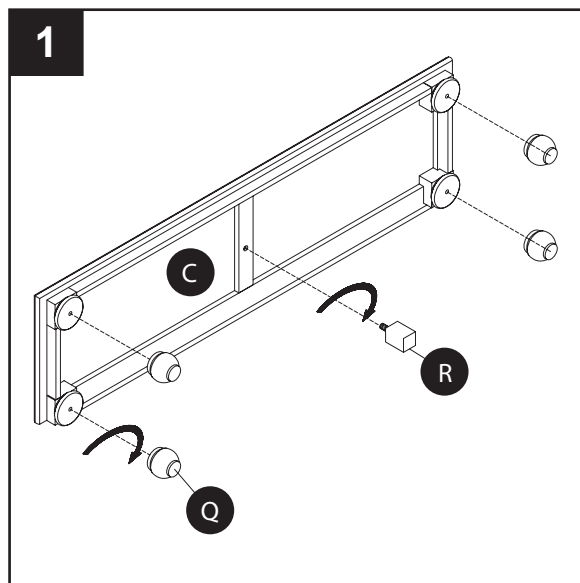

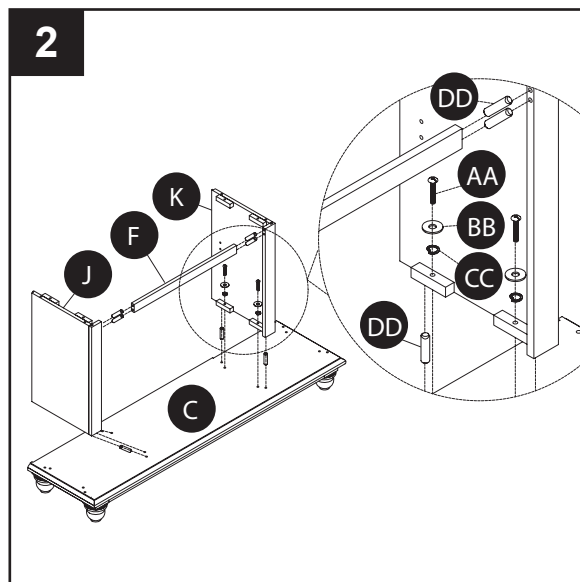

2. Insert two dowels (DD) into predrilled holes on each end of shelf rail (F). Slip one end of shelf rail (F) into predrilled holes in upper edge of left inner panel (J) and the other end into predrilled holes in upper edge of right inner panel (K). Press together until both joints are snug. Lay base (C) face up on a flat, level surface and insert four dowels (DD) into predrilled holes in center area of base (C). Slip panel assembly over dowels (DD) so that the dowels (DD) fit into predrilled holes in bottom edge of assembly. Insert two bolts (AA) through flat washers (BB), lock washers (CC), predrilled holes in edge blocks and into predrilled holes in base (C). Tighten with Phillips screwdriver (not included).



Repeat on opposite side.

Hardware Used

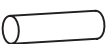
AA	Bolt		x 4
BB	Flat Washer		x 4
CC	Lock Washer		x 4
DD	Dowel		x 8

ASSEMBLY INSTRUCTIONS

3. Insert two dowels (DD) into predrilled holes in each end of top shelf (B). Slip one end of top shelf (B) into predrilled holes on inside face of left side panel (G) and the other end into predrilled holes on inside face of right side panel (H). Press together until both joints are snug.

Hardware Used

DD Dowel  x 4

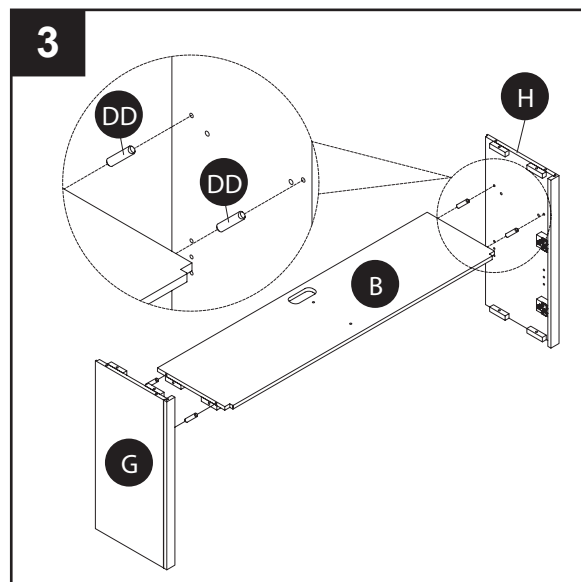

4. Insert four dowels (DD) into predrilled holes in base (C). Insert four dowels (DD) into predrilled holes in top edge of left and right inner panels (J&K). Set top shelf assembly over dowels (DD) in base (C) and inner panel assembly so that the dowels (DD) fit into predrilled holes in bottom edges of left and right side panels (G&H) and underside of top shelf (B). Press down until all joints are snug.

Hardware Used

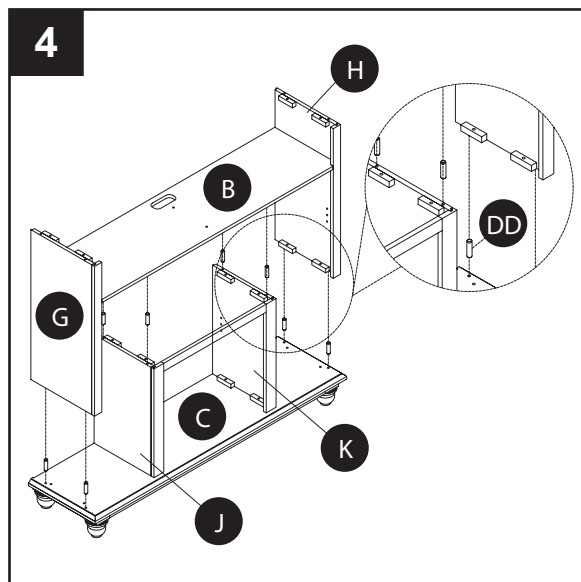

DD Dowel  x 8



ASSEMBLY INSTRUCTIONS

5. Insert two bolts (AA) through flat washers (BB), lock washers (CC), predrilled holes in edge blocks and into predrilled holes in base (C). Tighten with Phillips screwdriver (not included). Repeat on opposite side.

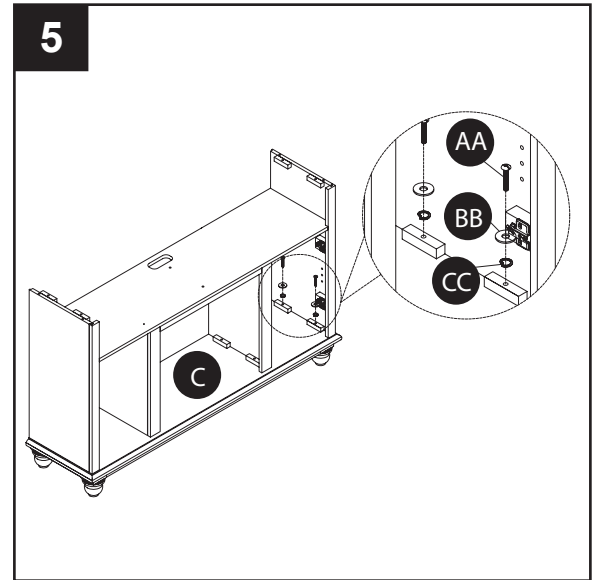

Hardware Used

AA	Bolt		x 4
BB	Flat Washer		x 4
CC	Lock Washer		x 4



6. Lay assembly on its back. Insert four bolts (AA) through flat washers (BB), lock washers (CC), predrilled holes in edge blocks and into predrilled holes on right side of assembly as illustrated. Tighten with Phillips screwdriver (not included). Repeat on opposite end.

Hardware Used

AA	Bolt		x 8
BB	Flat Washer		x 8
CC	Lock Washer		x 8

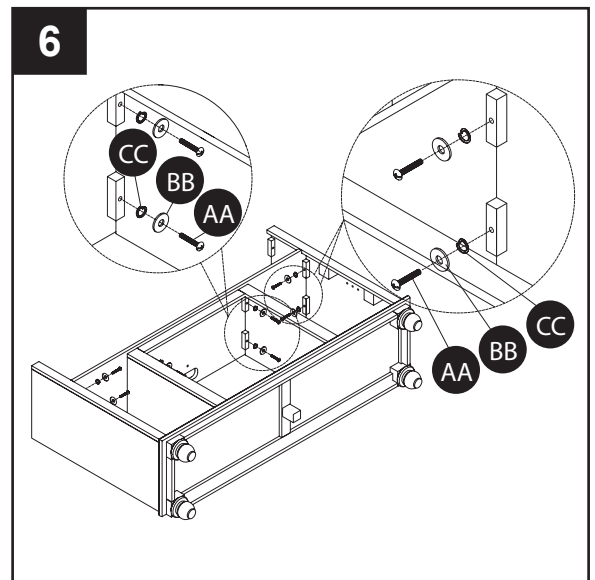

ASSEMBLY INSTRUCTIONS

7. With assembly sitting upright, insert two dowels (DD) into predrilled holes in top of top shelf (B). Slip top shelf divider (E) over dowels (DD) so that the dowels fit into predrilled holes in bottom edge. Press down until snug.



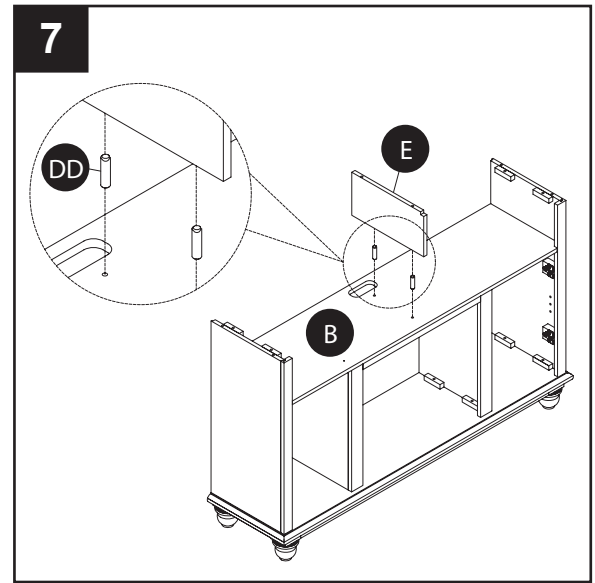

Hardware Used

DD	Dowel		x 2
-----------	-------	---	-----



8. With assembly sitting upright, insert six dowels (DD) into predrilled holes in top of edges of assembly. Slip top panel (A) over dowels (DD) so that the dowels fit into predrilled holes in underneath side of top panel (A). Insert two bolts (AA) through flat washers (BB), lock washers (CC), predrilled holes in edge blocks, and into predrilled holes in top panel (A). Tighten with Phillips screwdriver (not included). Repeat on opposite side.

Hardware Used

AA	Bolt		x 4
BB	Flat Washer		x 4
CC	Lock Washer		x 4
DD	Dowel		x 6

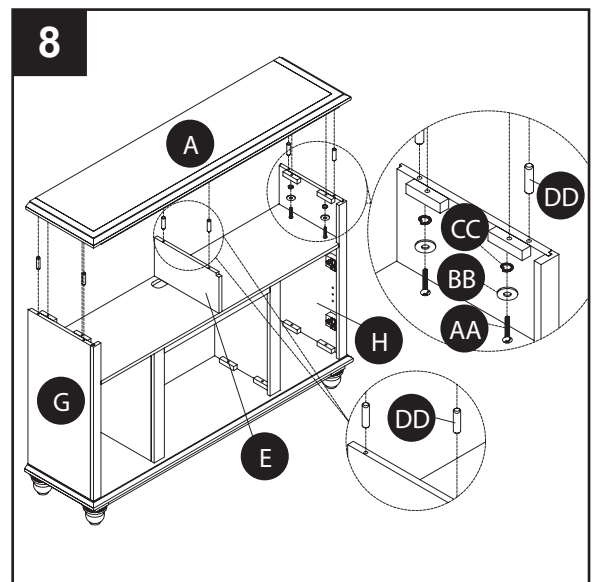

ASSEMBLY INSTRUCTIONS

9. Attach upper back panel (M) and lower back panels (L) by inserting screws (EE) into predrilled holes and tightening with Phillips screwdriver (not included).

Hardware Used

EE Screw  x 42

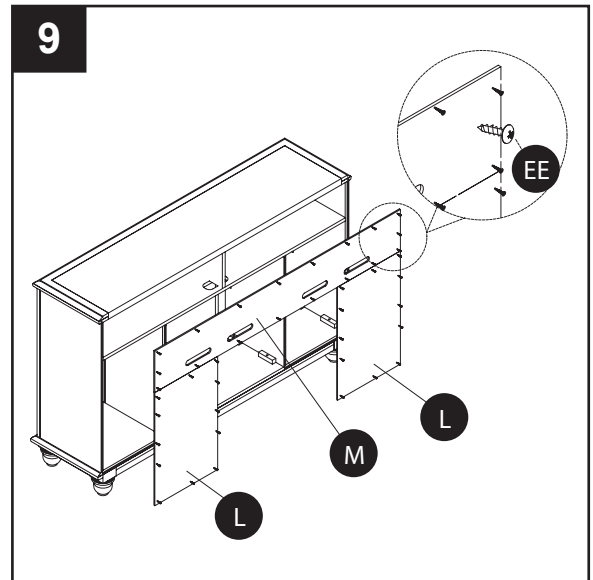

10. Insert shelf supports (HH) into predrilled holes as illustrated, keeping all shelf supports (HH) parallel to each other. Lay adjustable shelves (D) in place on each side of assembly.

Hardware Used

HH Shelf Support  x 8

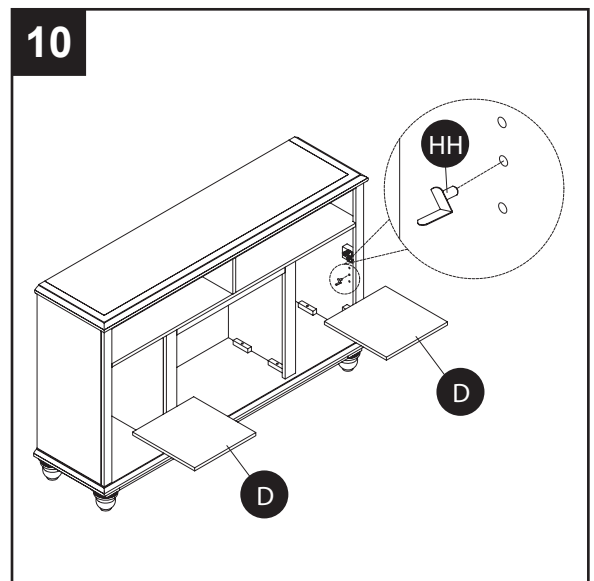

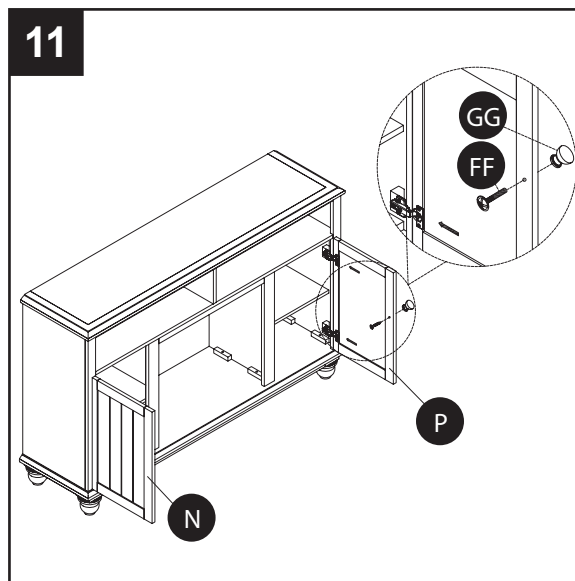

ASSEMBLY INSTRUCTIONS

11. Attach right cabinet door (P) to hinges on assembly. Attach cabinet door knob (GG) with knob screw (FF) inserted through predrilled hole in right cabinet door (P). Tighten with Phillips screwdriver (not included). Repeat with left cabinet door (N).

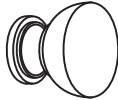

Hardware Used

GG	Cabinet Door Knob		x 2
FF	Knob Screw		x 2

CARE AND MAINTENANCE

- To maintain the finish, clean with a soft, slightly damp cloth and buff with a dry cloth.
- Wood furniture should never be dragged across a floor. The added stress from dragging the unit may cause the dragged edge to splinter or it may cause a joint to loosen.

ONE YEAR LIMITED WARRANTY

If within one year from the date of original purchase this item fails due to a defect in material or workmanship, we will replace or repair at our option, free of charge. To order parts or to obtain warranty service, call 1-877-447-4768, Monday – Friday, 8:30 a.m. – 4:30 p.m., CST. This warranty does not cover defects resulting from improper or abnormal use, misuse, accident, or alteration. Failure to follow all instructions in the owner's manual will also void this warranty. The manufacturer will not be liable for incidental or consequential damages. Some states do not allow the exclusion or limitation of incidental or consequential damages, so the above limitation or exclusion of incidental or consequential damages may not apply to you. This warranty gives you specific legal rights, and you may also have other rights which vary from state to state.

Variations in actual wood color and finishes which may result from natural characteristics of the wood, such as grain patterns, mineral streaks and the like, are not considered defects. As wood continues to move and age you may notice these slight differences in color, even on different parts of any individual unit. Sound knots and slight surface cracks are true personality of a quality piece of wood furniture.

REPLACEMENT PARTS LIST

For replacement parts, call our customer service department at 1-877-447-4768, 8:30 a.m. - 4:30 p.m., CST, Monday - Friday.

PART	DESCRIPTION	PART #
A	Top Panel	20-12-178
B	Top Shelf	20-12-179
C	Base	20-12-180
D	Adjustable Shelf	20-12-181
E	Top Shelf Divider	20-12-182
F	Shelf Rail	20-12-183
G	Left Side Panel	20-12-184
H	Right Side Panel	20-12-185
J	Left Inner Panel	20-12-186
K	Right Inner Panel	20-12-187
L	Lower Back Panel	20-12-188
M	Upper Back Panel	20-12-189
N	Left Cabinet Door	20-12-190
P	Right Cabinet Door	20-12-191
Q	Leg	20-12-192
R	Middle Leg	20-12-193
AA	Bolt	20-12-194
BB	Flat Washer	20-12-195
CC	Lock Washer	20-12-196
DD	Dowel	20-12-197
EE	Screw	20-12-198
FF	Knob Screw	20-12-199
GG	Cabinet Door Knob	20-12-200
HH	Shelf Support	20-12-201

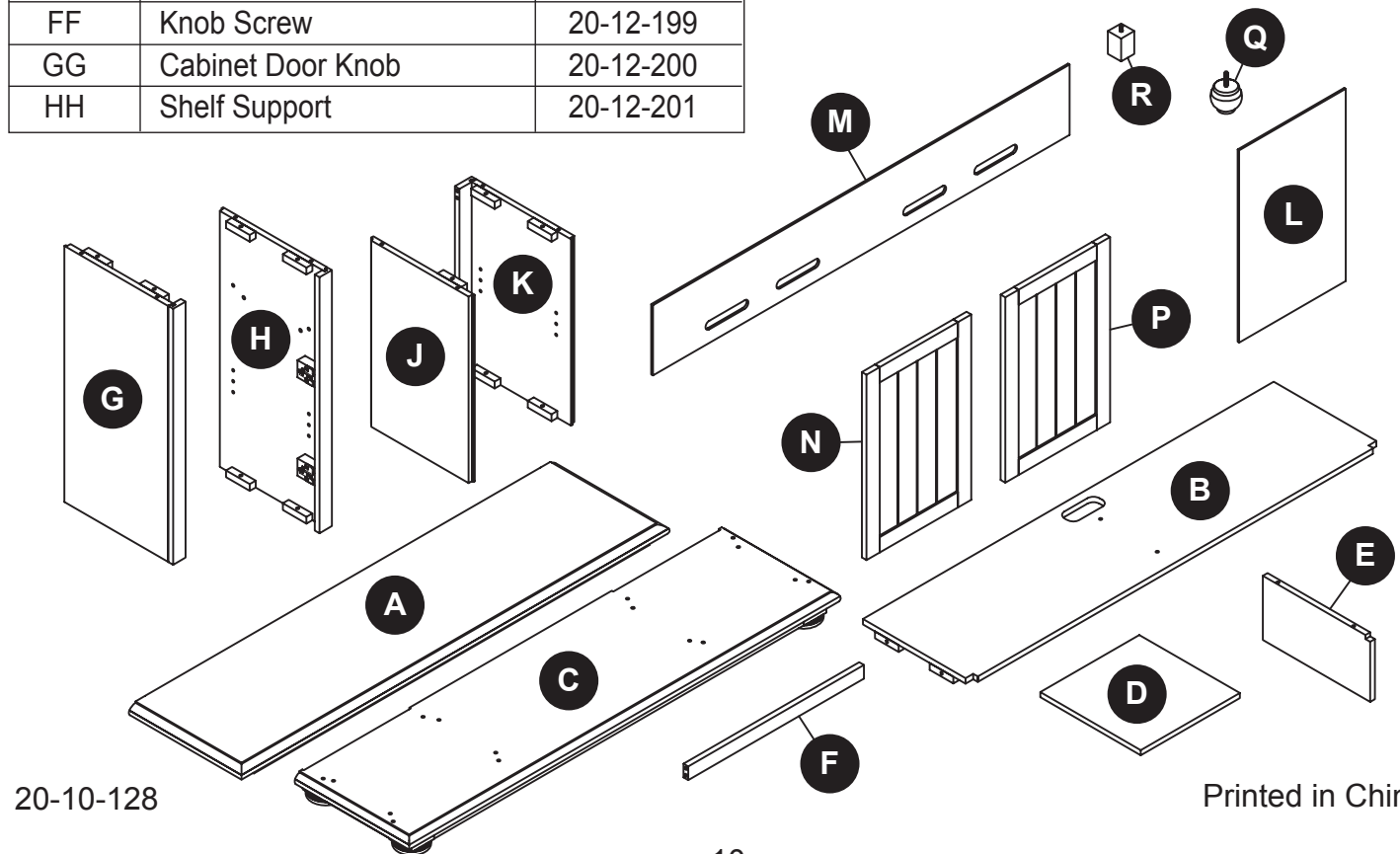
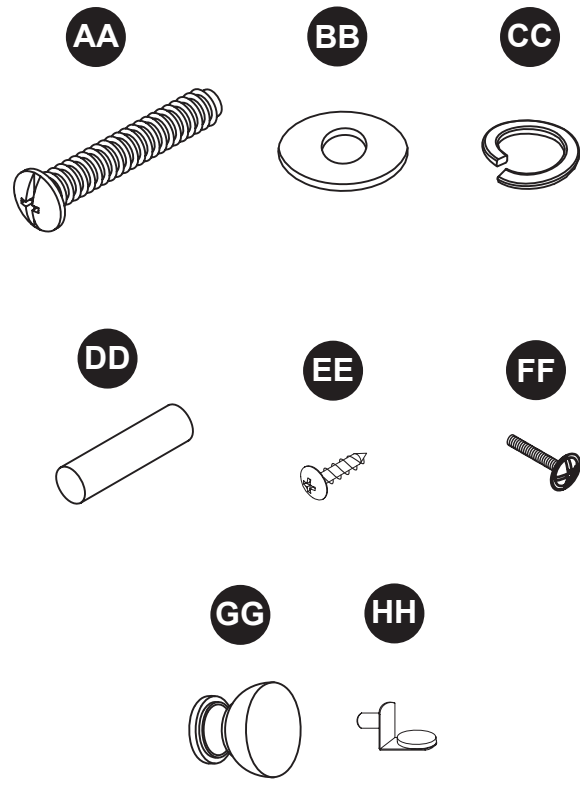



MANTEAU MULTIMÉDIA HÉRITAGE POUR FOYER DE 23 PO.

MODÈLE #23-29-65

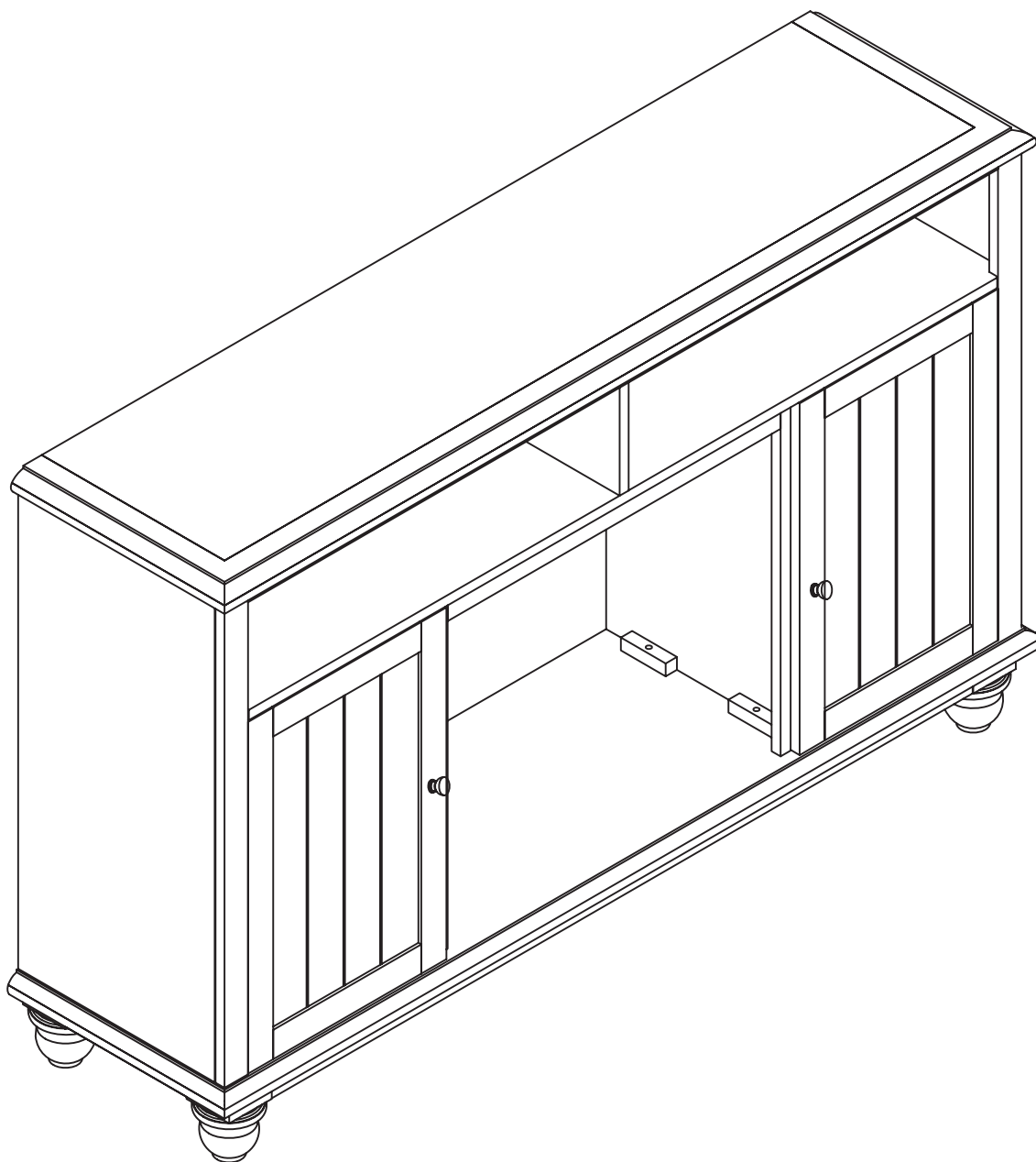

JOIGNEZ VOTRE REÇU ICI

Numéro de série _____ Date d'achat _____







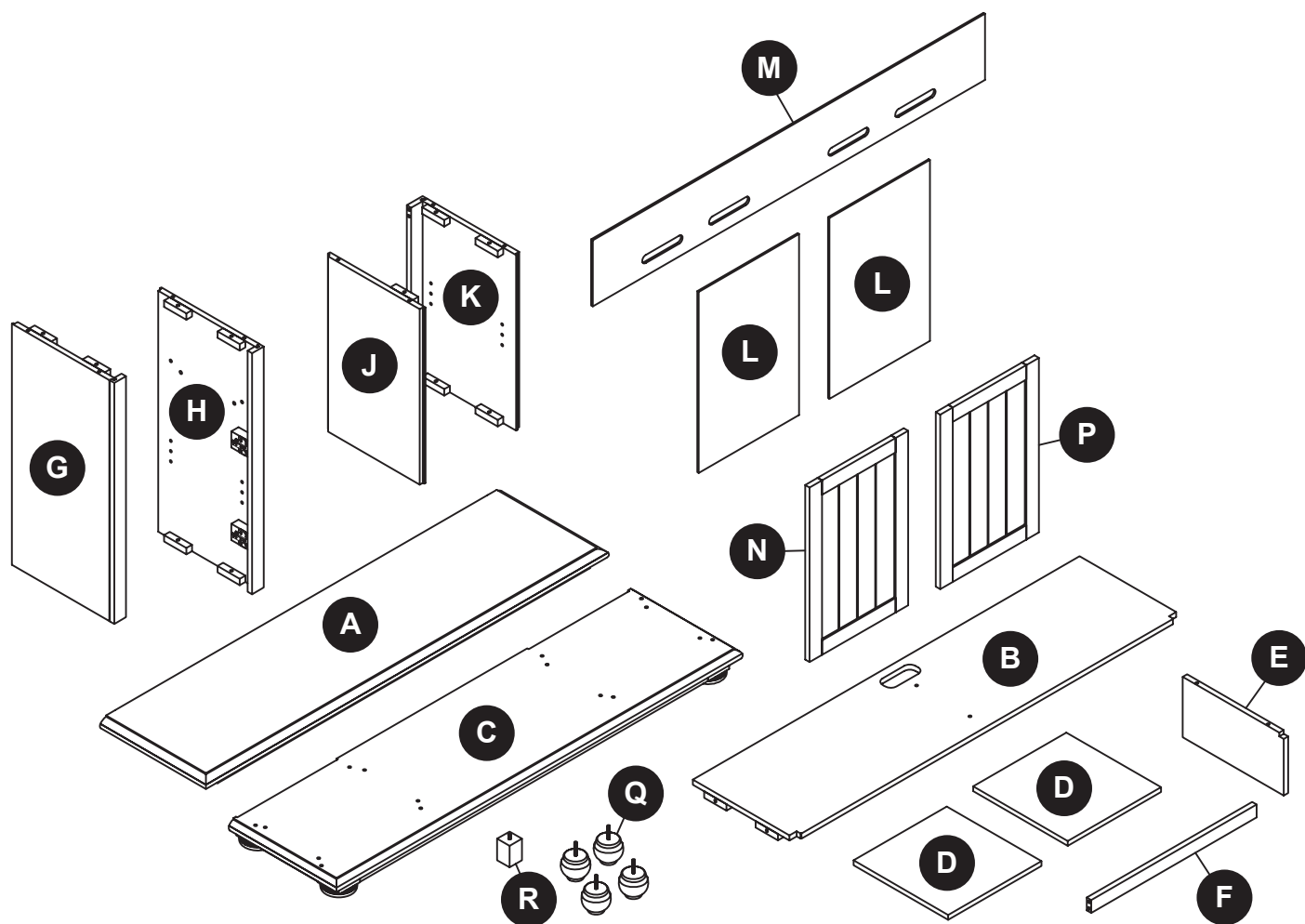

Des questions, des problèmes, des pièces manquantes? Avant de retourner l'article au détaillant, appelez notre service à la clientèle au 1 877 447-4768, entre 8 h 30 et 16 h 30 (HNC), du lundi au vendredi.

CONTENU DE L'EMBALLAGE

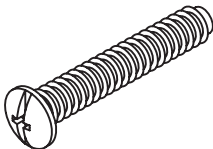
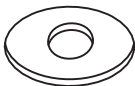

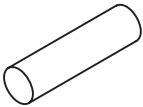
PIÈCE	DESCRIPTION	QUANTITÉ
A	Panneau supérieur	1
B	Tablette supérieure	1
C	Base	1
D	Tablette réglable	2
E	Diviseur de tablette supérieure	1
F	Montant de tablette	1
G	Panneau latéral gauche	1
H	Panneau latéral droit	1
J	Panneau intérieur gauche	1
K	Panneau intérieur droit	1
L	Panneau arrière inférieur	2
M	Panneau arrière supérieur	1
N	Porte d'armoire gauche	1
P	Porte d'armoire droite	1
Q	Pied	4
R	Pied du milieu	1

QUINCAILLERIE INCLUSE (grandeur réelle)

AA	BB	CC	DD	EE	FF	GG	HH
							
Boulon	Rondelle plate	Rondelle frein	Goujon	Vis	Vis pour bouton de porte	Bouton de porte d'armoire	Support de tablette
Qty. 20	Qty. 20	Qty. 20	Qty. 28	Qty. 42	Qty. 2	Qty. 2	Qty. 8

CONSIGNES DE SÉCURITÉ

Assurez-vous de lire et de comprendre l'intégralité de ce manuel avant de tenter d'assembler, d'utiliser ou d'installer le produit. Si vous avez des questions concernant ce produit, veuillez communiquer avec notre service à la clientèle au 1 877 447-4768, entre 8 h 30 et 16 h 30 (HNC), du lundi au vendredi.

AVERTISSEMENT

- Étant donné que ce manteau est lourd, nous vous recommandons de l'assembler près de l'endroit où vous souhaitez l'installer.
- Nous vous recommandons de déplacer le manteau assemblé avec l'aide d'une autre personne afin d'éviter de vous blesser.

PRÉPARATION

Avant de commencer l'assemblage du produit, assurez-vous d'avoir toutes les pièces. Comparez les pièces dans l'emballage avec la liste du contenu de l'emballage et celle de la quincaillerie ci-dessus. S'il y a des pièces manquantes ou endommagées, ne tentez pas d'assembler le produit. Communiquez avec le service à la clientèle pour obtenir des pièces de rechange.

Temps d'assemblage approximatif : 45 minutes.

Outils nécessaires pour l'assemblage (non inclus): et tournevis cruciforme

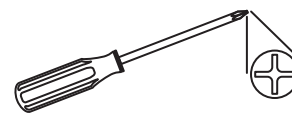

INSTRUCTIONS POUR L'ASSEMBLAGE

1. Visser chacun des quatre pieds (Q) dans les trous prépercés situés dans les quatre coins de la base (C). Visser le pied du milieu (R) dans le trou situé dans le support central de la base (C).

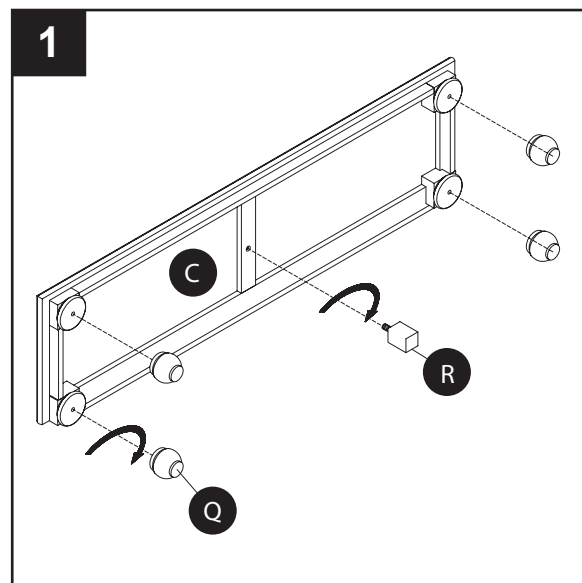

2. Insérer deux goujons (DD) dans les trous prépercés situés sur chaque extrémité du montant de tablette (F). Glisser une extrémité du montant de tablette (F) dans les trous prépercés situés sur le bord supérieur du panneau inférieur gauche (J). Glisser l'autre extrémité dans les trous prépercés situés sur le bord inférieur du panneau intérieur droit (K). Appliquer une pression des deux côtés jusqu'à ce que les deux joints soient bien emboîtés. Placer la base (C) l'avant vers le haut sur une surface plane, de niveau, et insérer les quatre goujons (DD) dans les trous prépercés situés dans la section centrale de la base (C). Glisser l'ensemble de panneaux par-dessus les goujons (DD) de manière à ce que les goujons (DD) emboîtent dans les trous prépercés sur le bord inférieur de l'ensemble. Introduire deux boulons (AA) dans des rondelles plates, des rondelles frein (CC), les trous prépercés dans les blocs du bord et les trous prépercés de la base (C). Serrer à l'aide d'un tournevis cruciforme (non inclus). Répéter du côté opposé.

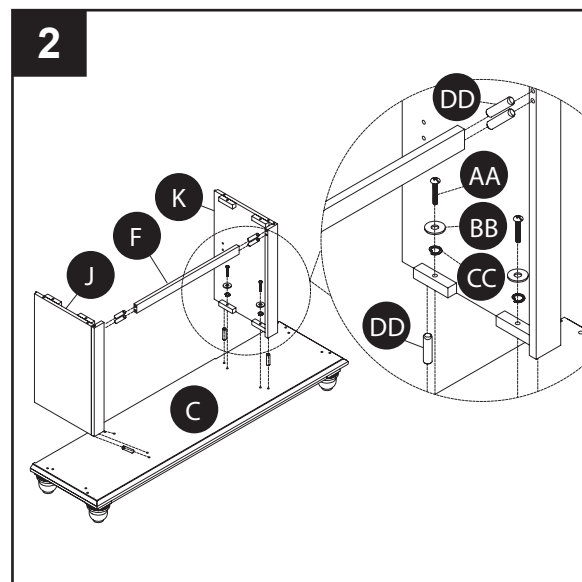

Quincaillerie utilisée

AA	Boulon		x 4
BB	Rondelle		x 4
CC	Rondelle de blocage		x 4
DD	Goujon		x 8

INSTRUCTIONS POUR L'ASSEMBLAGE

3. Insérer deux goujons (DD) dans les trous prépercés dans chaque extrémité de la tablette supérieure (B). Glisser une extrémité de la tablette supérieure (B) dans les trous prépercés situés sur la surface intérieure du panneau latéral gauche (G) et glisser l'autre extrémité dans les trous prépercés situés sur la surface intérieure du panneau latéral droit (H). Appliquer une pression des deux côtés vers l'intérieur jusqu'à ce que les deux joints soient bien emboîtés.

Quincaillerie utilisée

DD Goujon  x 4

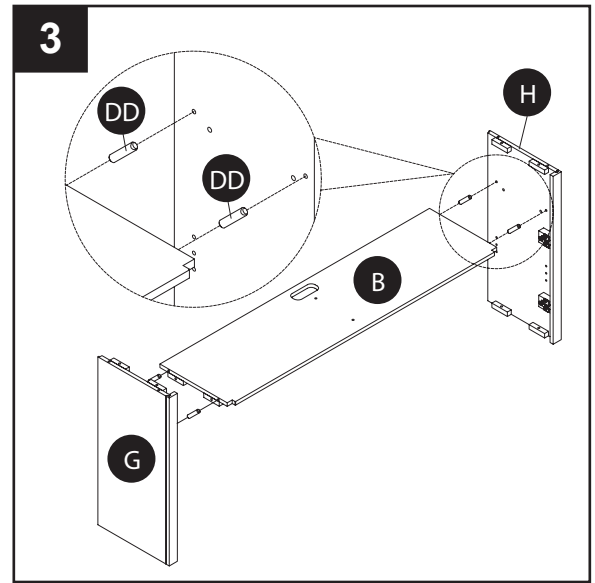

4. Insérer quatre goujons (DD) dans les trous prépercés situés dans la base (C). Insérer quatre goujons (DD) dans les trous prépercés situés sur le bord supérieur des panneaux intérieurs gauche et droit (J et K). Mettre l'ensemble de tablette supérieure par-dessus les goujons (DD) déjà insérés dans la base (C) et l'ensemble de panneaux intérieurs de manière à ce que les goujons (DD) rentrent dans les trous prépercés situés dans les bords inférieurs des panneaux latéraux droit et gauche (G et H) et le revers de la tablette supérieure (B). Appliquer une pression vers le bas jusqu'à ce que tous les joints soient bien emboîtés.

Quincaillerie utilisée

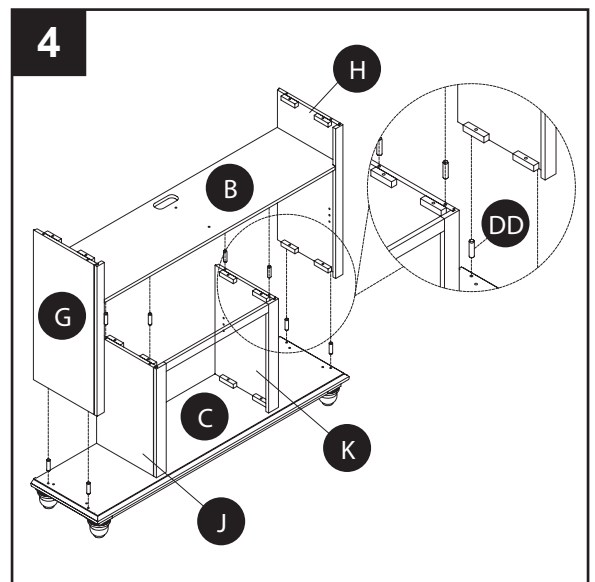

DD Goujon  x 8



INSTRUCTIONS POUR L'ASSEMBLAGE

5. Introduire deux boulons (AA) dans des rondelles plates (BB), rondelles frein (CC), les trous prépercés des blocs du bord et les trous prépercés de la base (C). Serrer les boulons à l'aide d'un tournevis cruciforme (non inclus). Répéter du côté opposé.

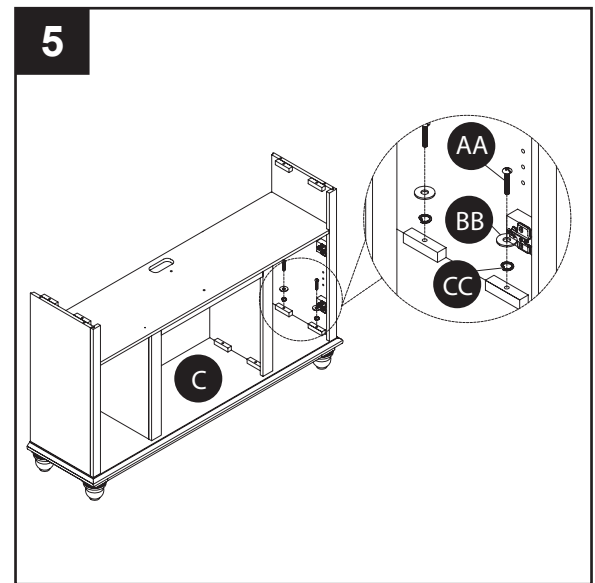

Quincaillerie utilisée

AA	Boulon		x 4
BB	Rondelle		x 4
CC	Rondelle de blocage		x 4



6. Placer l'ensemble le côté arrière vers le bas. Introduire quatre boulons (AA) dans des rondelles plates (BB), des rondelles frein (CC), les trous prépercés dans les blocs du bord et les trous prépercés du côté droit de l'ensemble, comme illustré. Serrer à l'aide d'un tournevis cruciforme (non inclus). Répéter du côté opposé.

Quincaillerie utilisée

AA	Boulon		x 8
BB	Rondelle		x 8
CC	Rondelle de blocage		x 8

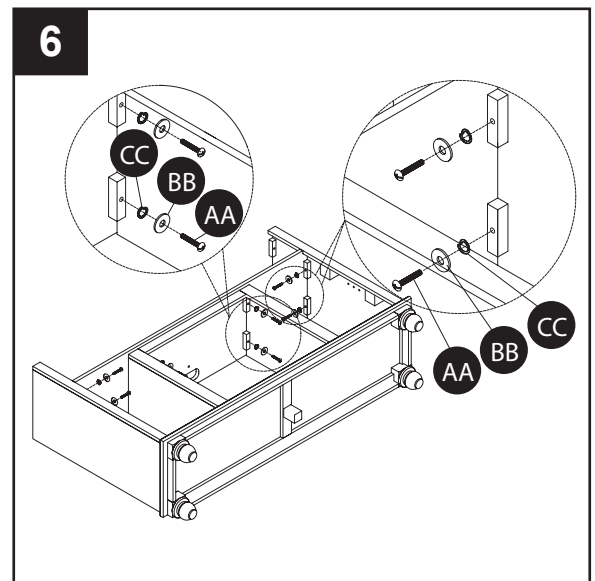

INSTRUCTIONS POUR L'ASSEMBLAGE

7. Mettre l'ensemble debout et insérer deux goujons (DD) dans les trous prépercés situés dans le dessus de la tablette supérieure (B). Glisser le diviseur de tablette (E) par-dessus les goujons (DD) de manière à ce que les goujons rentrent dans les trous prépercés du bord inférieur. Appliquer une pression vers le bas jusqu'à ce que le tout soit bien emboîté.



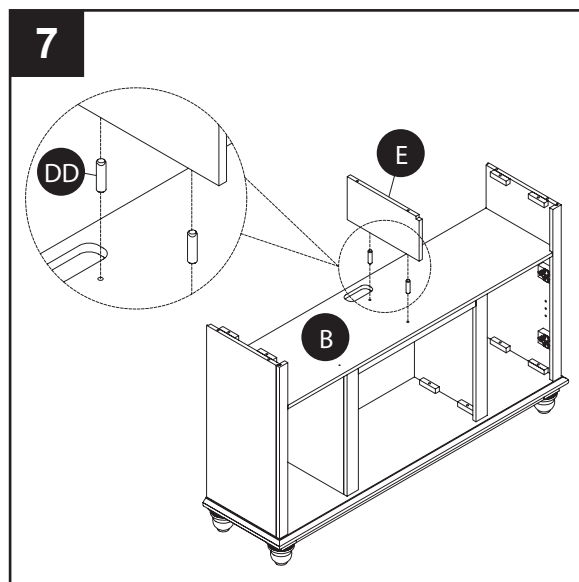

Quincaillerie utilisée

DD Goujon  x 2



8. . L'ensemble debout, insérer six goujons (DD) dans les trous prépercés situés dans les bords supérieurs de l'ensemble. Glisser le panneau supérieur (A) par-dessus les goujons (DD) de manière à ce que les goujons rentrent dans les trous prépercés situés dans le dessous du panneau supérieur (A). Introduire deux boulons (AA), des rondelles plates (BB), des rondelles frein (CC), les trous prépercés dans les blocs du bord et les trous prépercés dans le panneau supérieur (A). Serrer à l'aide d'un tournevis cruciforme (non inclus). Répéter du côté opposé.

Quincaillerie utilisée

AA Boulon  x 4
BB Rondelle  x 4
CC Rondelle de blocage  x 4
DD Goujon  x 6

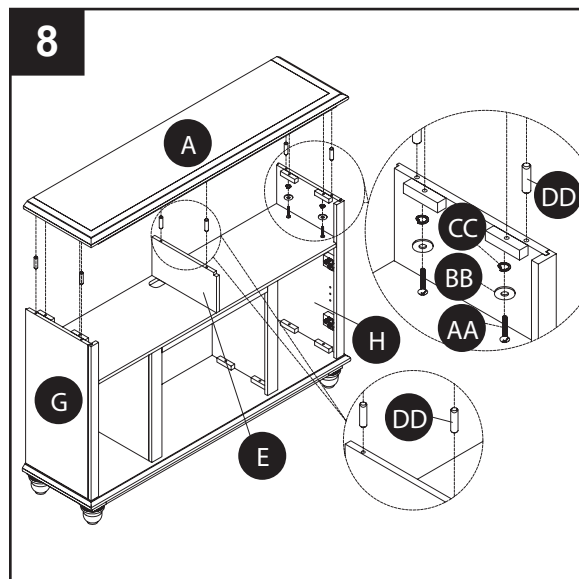

INSTRUCTIONS POUR L'ASSEMBLAGE

9. Fixer le panneau arrière supérieur (M) au panneau arrière inférieur (L) en insérant des vis (EE) dans les trous prépercés et en les serrant à l'aide d'un tournevis cruciforme (non inclus).

Quincaillerie utilisée

EE Vis  x 42

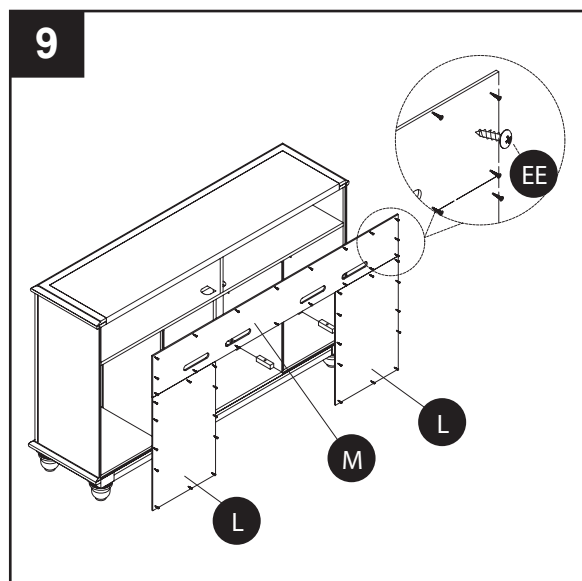

10. 10. Insérer les supports de tablette (HH) dans les trous prépercés comme illustré en s'assurant de garder tous les supports de tablette parallèles les uns aux autres. Poser les tablettes réglables (D) à l'endroit indiqué de chaque côté de l'ensemble.

Quincaillerie utilisée

HH Support de tablette  x 8

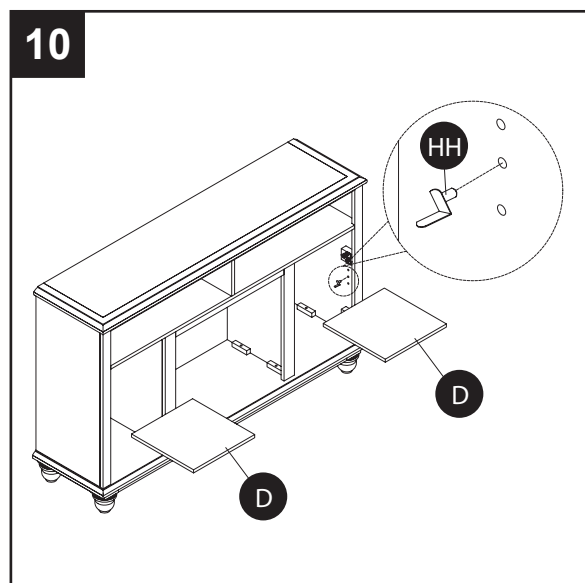

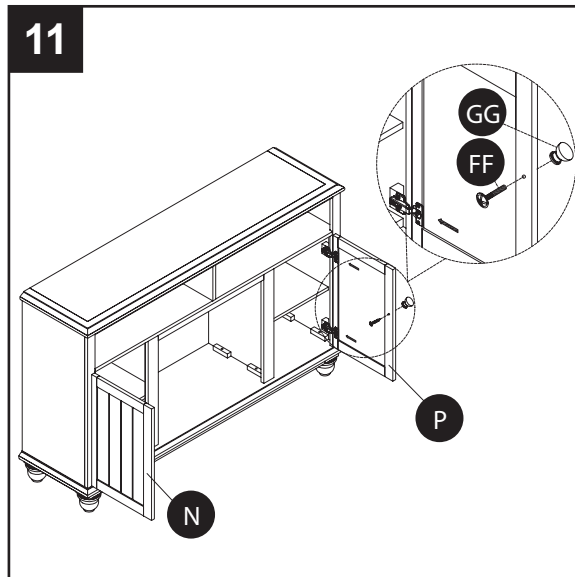

INSTRUCTIONS POUR L'ASSEMBLAGE

11. Fixer la porte d'armoire droite (P) aux charnières sur l'ensemble. Fixer le bouton de porte d'armoire (GG) à l'aide d'une vis pour bouton (FF) insérée dans le trou prépercé dans la porte d'armoire droite (P). Serrer à l'aide d'un tournevis cruciforme (non inclus). Répéter cette procédure pour fixer la porte d'armoire gauche (N).

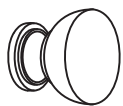

Quincaillerie utilisée

	Bouton de porte d'armoire		x 2
	Vis pour bouton de porte		x 2

ENTRETIEN

- Pour conserver le fini, nettoyez à l'aide d'un linge doux et légèrement humide, puis essuyez avec un linge sec.
- Les meubles en bois ne devraient jamais être traînés. La tension supplémentaire causée par le glissement du meuble sur le sol pourrait faire en sorte que les extrémités se fendillent ou que les joints se desserrent.

GARANTIE LIMITÉE DE UN AN

Si cet article présente des défauts de matériaux ou de fabrication au cours de la première année suivant la date d'achat d'origine, nous le réparerons ou le remplacerons à notre discrétion, sans frais. Pour commander des pièces ou faire une réclamation, communiquez avec notre service à la clientèle au 1 877 447-4768, du lundi au vendredi, entre 8 h 30 et 16 h 30 (HNC). Cette garantie ne couvre pas les défauts résultant d'un usage inadéquat, anormal ou inapproprié, d'un accident ou d'une modification. Si vous n'observez pas toutes les instructions contenues dans le guide d'utilisation, cette garantie sera invalide. Le fabricant n'est pas responsable des dommages accessoires ou consécutifs. Certains États ou certaines provinces ne permettent pas l'exclusion ou la limitation des dommages accessoires ou consécutifs, de sorte que la limitation ci-dessus ou l'exclusion des dommages accessoires ou consécutifs peuvent ne pas s'appliquer à vous. La présente garantie vous confère des droits précis. Il est possible que vous bénéficiiez également d'autres droits, qui varient d'un État ou d'une province à l'autre.

Les variations de teintes et de finis pouvant être causées par les caractéristiques naturelles du bois, notamment le grain et les rainures minérales, ne constituent pas des défauts. Comme le bois continue de travailler et de vieillir, il est possible que vous remarquiez de légères variations de couleur, et ce, même entre les différentes parties d'un même meuble. Les nœuds sains et les légères fissures constituent l'essence même d'un meuble en bois de qualité.

LISTE DES PIÈCES DE RECHANGE

Pour obtenir des pièces de rechange, communiquez avec le service à la clientèle au 1 877 447-4768, entre 8 h 30 et 16 h 30 (HNC), du lundi au vendredi.

PIÈCE	DESCRIPTION	N° DE PIÈCE
A	Panneau supérieur	20-12-178
B	Tablette supérieure	20-12-179
C	Base	20-12-180
D	Tablette réglable	20-12-181
E	Diviseur de tablette supérieure	20-12-182
F	Montant de tablette	20-12-183
G	Panneau latéral gauche	20-12-184
H	Panneau latéral droit	20-12-185
J	Panneau intérieur gauche	20-12-186
K	Panneau intérieur droit	20-12-187
L	Panneau arrière inférieur	20-12-188
M	Panneau arrière supérieur	20-12-189
N	Porte d'armoire gauche	20-12-190
P	Porte d'armoire droite	20-12-191
Q	Pied	20-12-192
R	Pied du milieu	20-12-193
AA	Boulon	20-12-194
BB	Rondelle plate	20-12-195
CC	Rondelle frein	20-12-196
DD	Goujon	20-12-197
EE	Vis	20-12-198
FF	Vis pour bouton de porte	20-12-199
GG	Bouton de porte d'armoire	20-12-200
HH	Support de tablette	20-12-201

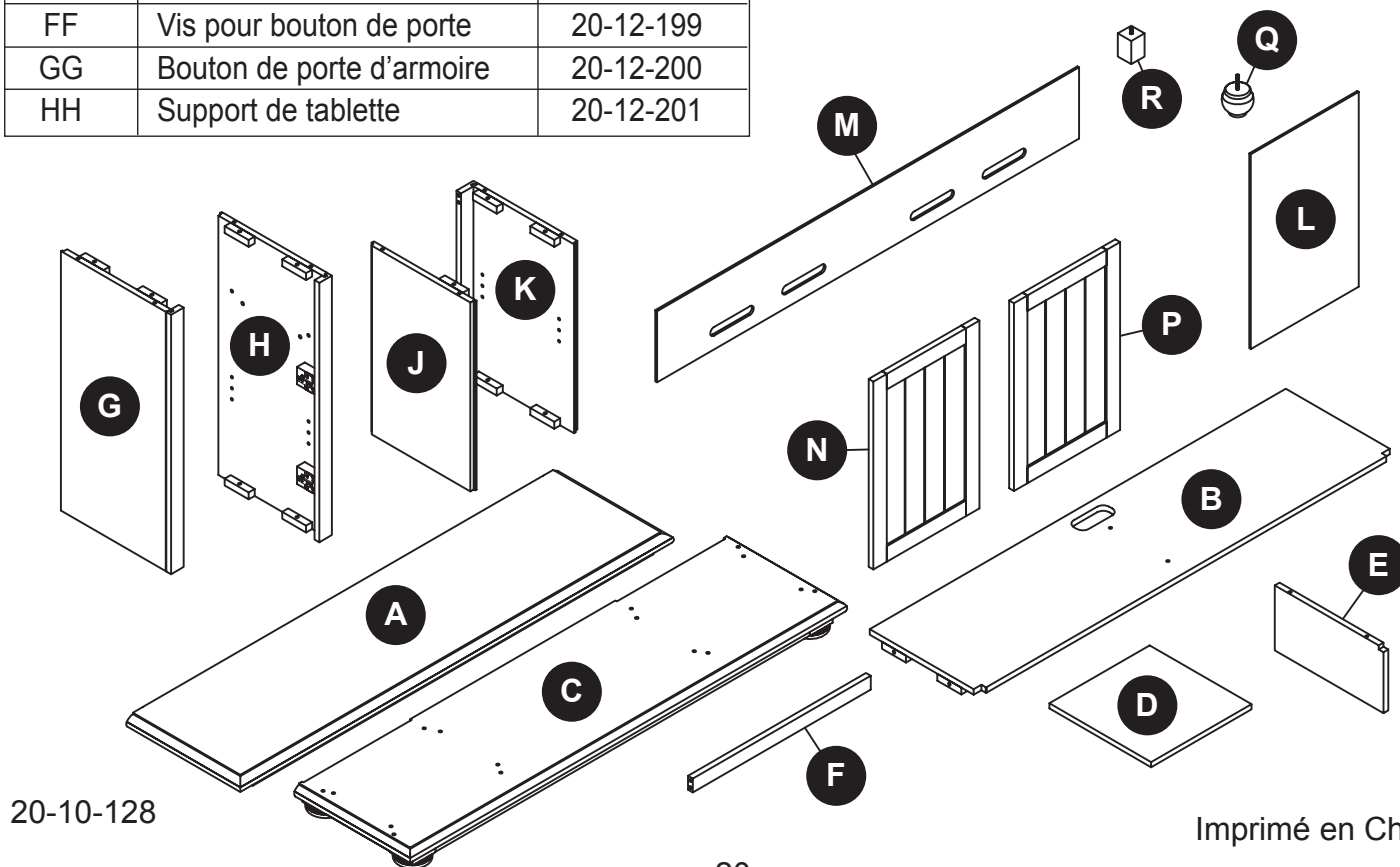
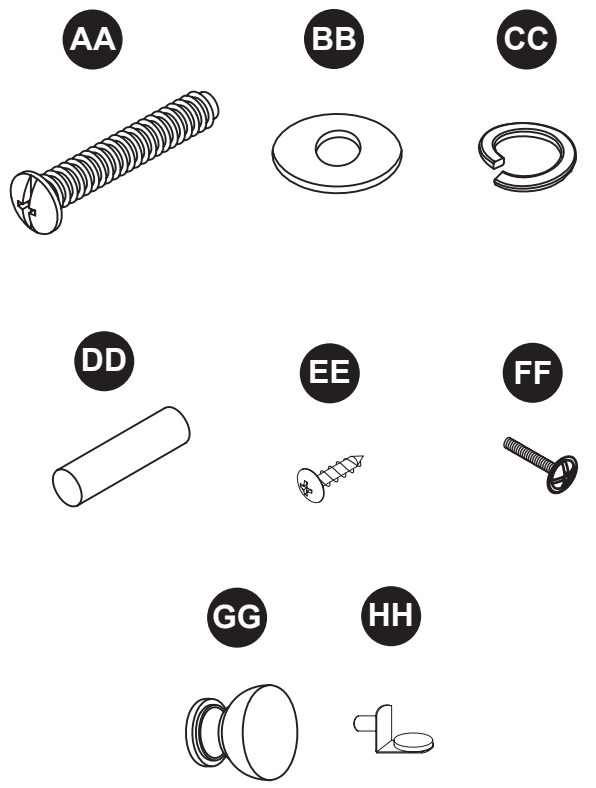

MANTO HERITAGE MEDIA PARA MUEBLE DE CHIMENEA DE 23 PULG.

MODELO #23-29-65

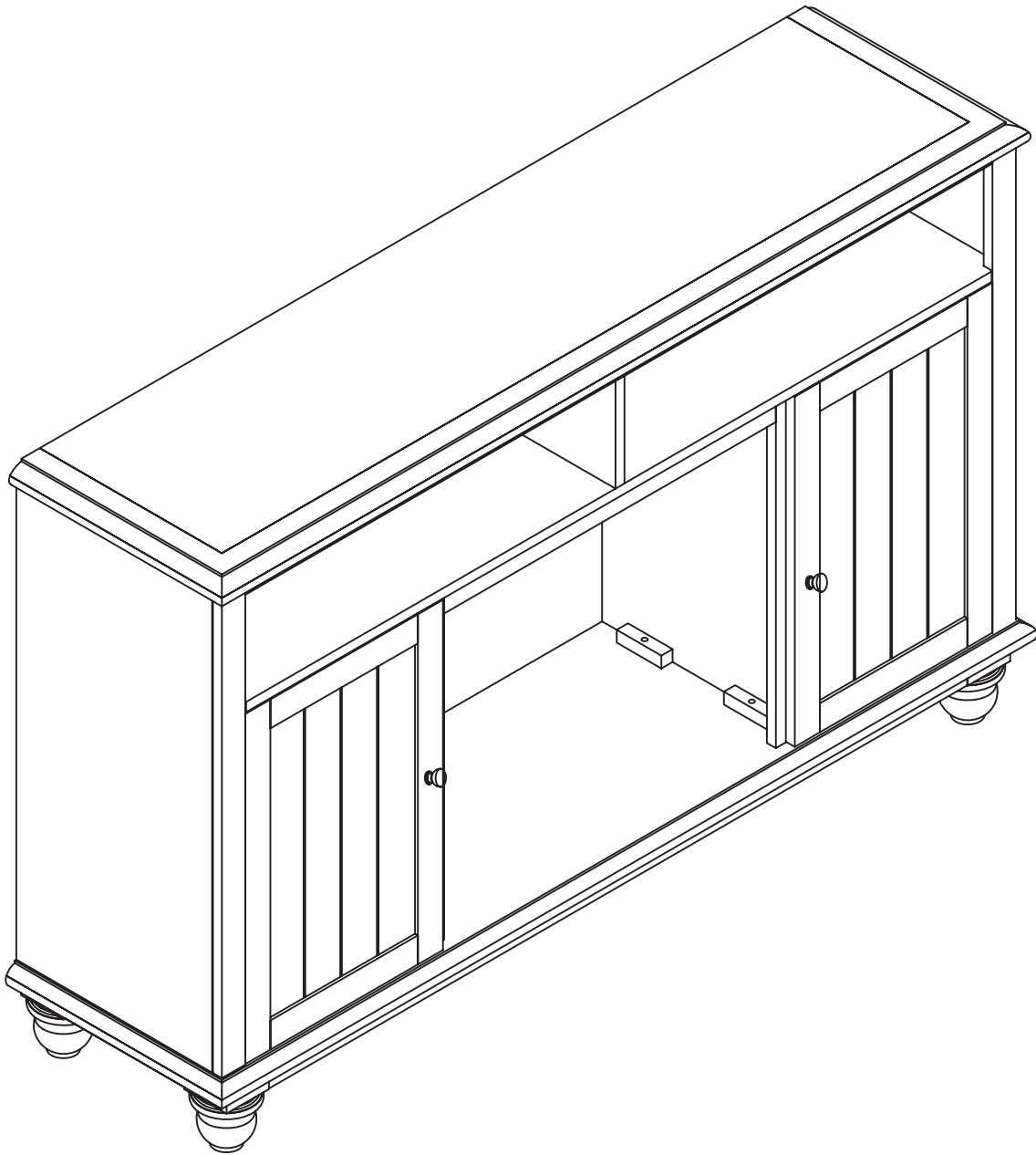

ADJUNTE SU RECIBO AQUÍ

Número de serie _____ Fecha de compra _____



¿Preguntas, problemas, piezas faltantes? Antes de volver a la tienda, llame a nuestro Departamento de Servicio al Cliente al 1-877-447-4768, de lunes a viernes de 8:30 a.m. a 4:30 p.m., hora central estándar.

CONTENIDO DEL PAQUETE

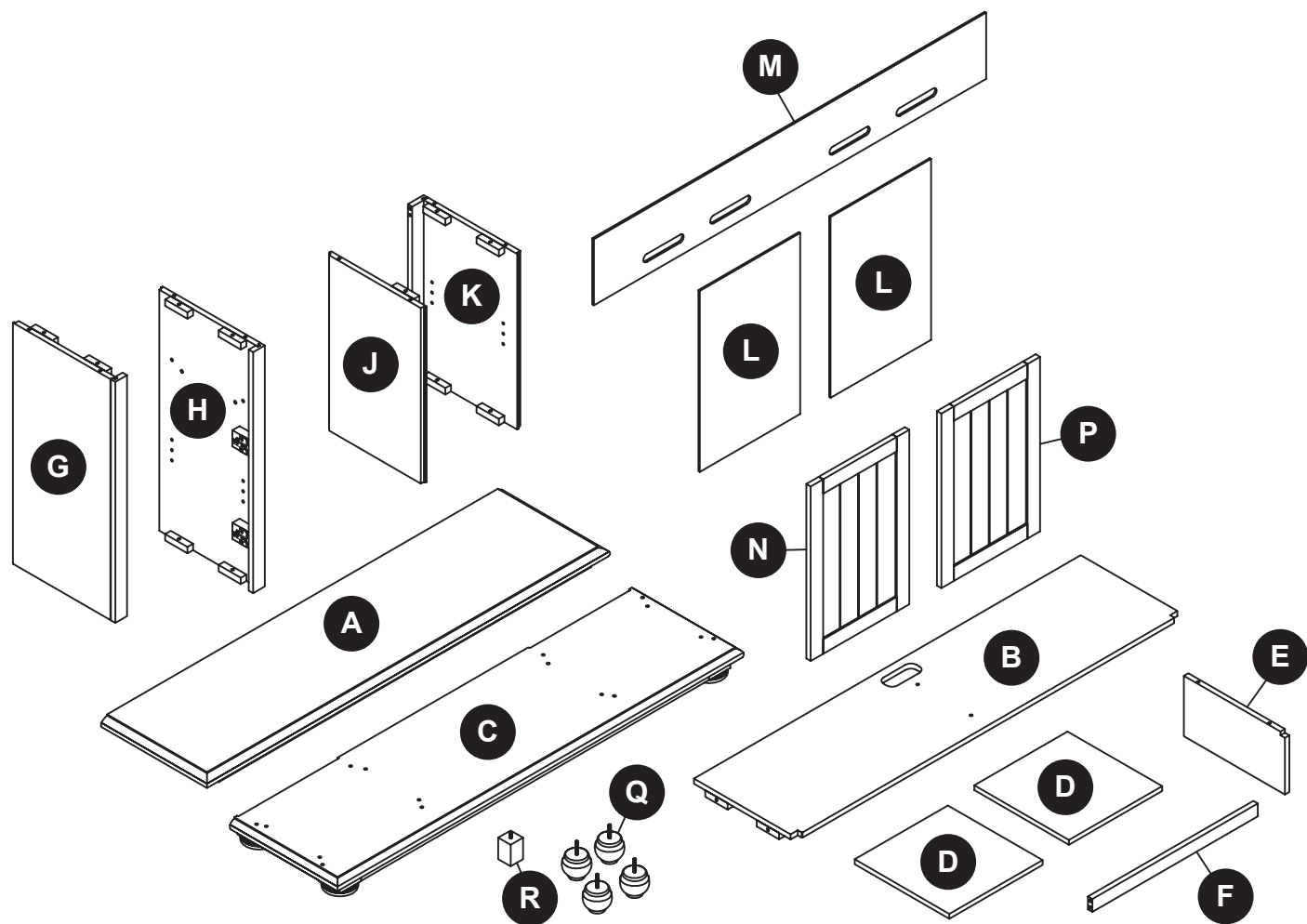

PIEZA	DESCRIPCIÓN	CANTIDAD
A	Panel Superior	1
B	Repisa Superior	1
C	Base	1
D	Repisa Ajustable	2
E	Separador de la Repisa Superior	1
F	Riel para Repisa	1
G	Panel del Lado Izquierdo	1
H	Panel del Lado Derecho	1
J	Panel Interior Izquierdo	1
K	Panel Interior Derecho	1
L	Panel Trasero Inferior	2
M	Panel Trasero Superior	1
N	Puerta del Gabinete Izquierdo	1
P	Puerta del Gabinete Derecha	1
Q	Pata	4
R	Pata de la Mitad	1

ADITAMENTOS (se muestran en tamaño real)

AA	BB	CC	DD	EE	FF	GG	HH
							
Perno	Arandela Plana	Arandela de seguridad	Espigo	Tornillo	Tornillo de Perilla	Perilla de la Puerta del Gabinete	Soporte de Repisa
Qty. 20	Qty. 20	Qty. 20	Qty. 28	Qty. 42	Qty. 2	Qty. 2	Qty. 8

INFORMACIÓN DE SEGURIDAD

Lea y comprenda completamente este manual antes de intentar ensamblar, usar o instalar el producto.

ADVERTENCIA

- La repisa para chimenea es pesada y se debe ensamblar cerca de su ubicación deseada.
- Se recomienda que dos personas muevan la repisa ensamblada para evitar lesiones.

PREPARACIÓN

Antes de comenzar a ensamblar el producto, asegúrese de tener todas las piezas. Compare las piezas con la lista del contenido del paquete y los aditamentos mencionados anteriormente. No intente ensamblar el producto si falta alguna pieza o si éstas están dañadas.

Tiempo estimado de ensamblaje: 45 minutos

Herramientas necesarias para el ensamblaje (no se incluye): destornillador Phillips



INSTRUCCIONES DE ENSAMBLAJE

1. Atornille cada una de las cuatro patas (Q) dentro de los huecos pre-perforados en cada esquina de la base (C). Atornille la pata de la mitad (R) dentro del hueco pre-perforado en la abrazadera central de la base (C).

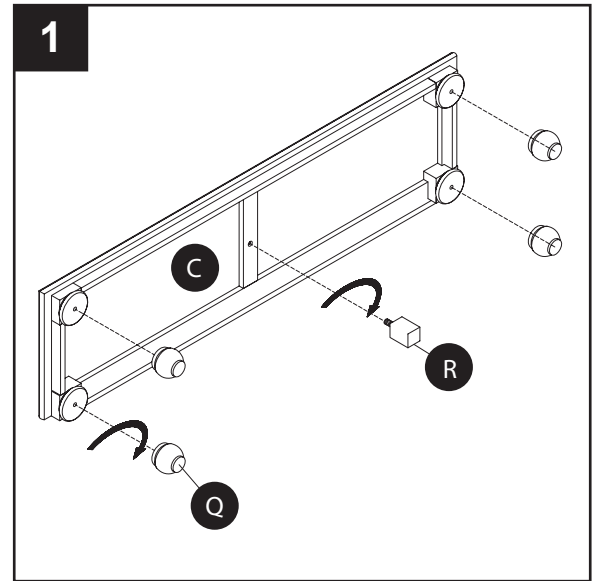

2. Inserte dos espigos (DD) dentro de los huecos pre-perforados en cada extremo del riel de la repisa (F). Deslice un extremo del riel de la repisa (F) dentro de los huecos pre-perforados en el borde superior del panel interior izquierdo (J) y el otro extremo dentro de los huecos pre-perforados en el borde superior del panel interior derecho (K). Júntelos haciendo presión hasta que ambas uniones estén ajustadas. Acueste la base (C) boca arriba sobre una superficie plana y nivelada e inserte cuatro espigos (DD) dentro de los huecos pre-perforados en el área central de la base (C). Deslice el panel ensamblado sobre espigos (DD) de tal forma que los espigos (DD) encajen dentro de los huecos pre-perforados en el borde inferior del ensamblado. Inserte dos pernos (AA) a través de arandelas planas (BB), arandelas de seguridad (CC), los huecos pre-perforados en los bloques del borde y dentro de los huecos pre-perforados en la base (C). Apriete con destornillador de estrella (no incluido). Repita el proceso sobre el lado opuesto.

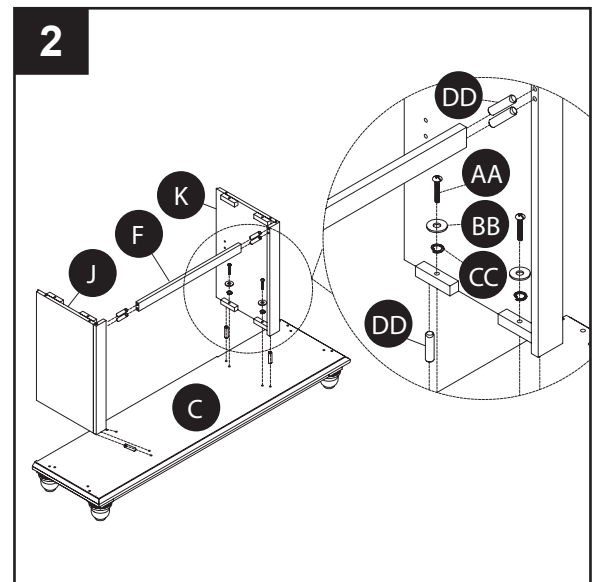

Aditamentos utilizados

AA	Perno		x 4
BB	Arandela Plana		x 4
CC	Arandela de Seguridad		x 4
DD	Espigo		x 8

INSTRUCCIONES DE ENSAMBLAJE

3. Inserte dos espigos (DD) dentro de los huecos pre-perforados en cada extremo de la repisa superior (B). Deslice un extremo de la repisa superior (B) dentro de los huecos pre-perforados sobre la cara interior del panel del lado izquierdo (G) y el otro extremo dentro de los huecos pre-perforados sobre la cara interior del panel del lado derecho (H). Júntelos haciendo presión hasta que ambas uniones estén ajustadas.

Aditamentos utilizados

DD Espigo  x 4

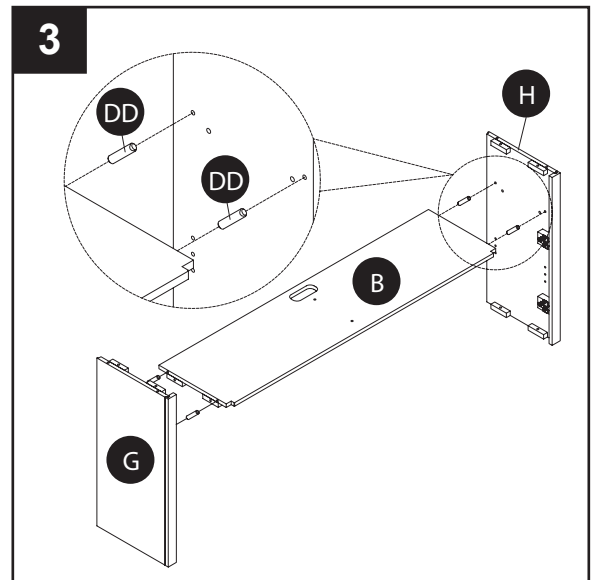

4. Inserte cuatro espigos (DD) dentro de los huecos pre-perforados en la base (C). Inserte cuatro espigos (DD) dentro de los huecos pre-perforados en el borde superior de los paneles interiores izquierdo y derecho (J y K). Coloque el ensamblado de la repisa superior sobre los espigos (DD) en la base (C) y el ensamblado del panel interior, de tal forma que los espigos (DD) encajen dentro de los huecos pre-perforados en los bordes inferiores de los paneles laterales izquierdo y derecho (G y H) y la cara inferior de la repisa superior (B). Presione hacia abajo hasta que todas las uniones estén ajustadas.

Aditamentos utilizados

DD Espigo  x 8

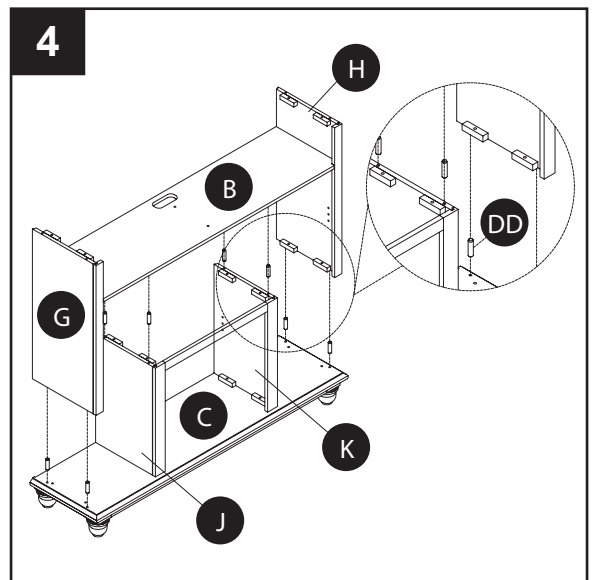

INSTRUCCIONES DE ENSAMBLAJE

5. Inserte dos pernos (AA) a través de arandelas planas (BB), arandelas de seguridad (CC), los huecos pre-perforados en los bloques del borde y dentro los huecos pre-perforados en la base (C). Apriete con destornillador de estrella (no incluido). Repita el proceso sobre el lado opuesto.

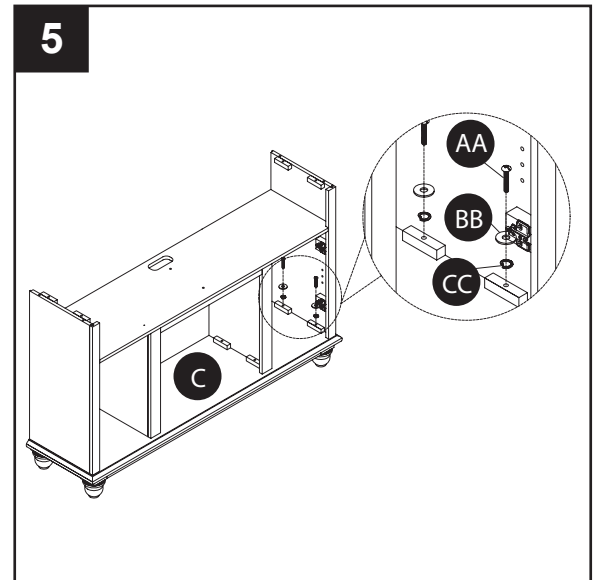

Aditamentos utilizados

AA	Perno		x 4
BB	Arandela Plana		x 4
CC	Arandela de Seguridad		x 4



6. Acueste el ensamblado sobre su espalda. Inserte cuatro pernos (AA) a través de arandelas planas (BB), arandelas de seguridad (CC), los huecos pre-perforados en los bloques del borde y dentro de los huecos pre-perforados en el lado derecho del ensamblado como se ilustra. Apriete con destornillador de estrella (no incluido). Repita el proceso sobre el lado opuesto.

Aditamentos utilizados

AA	Perno		x 8
BB	Arandela Plana		x 8
CC	Arandela de Seguridad		x 8

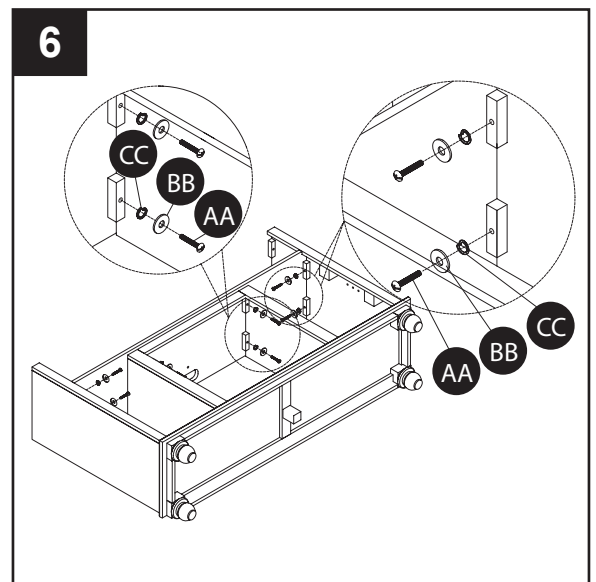

INSTRUCCIONES DE ENSAMBLAJE

7. Teniendo el ensamblado en posición vertical, inserte dos espigos (DD) dentro de los huecos pre-perforados en la parte de arriba de la repisa superior (B). Deslice el separador de la repisa superior (E) sobre los espigos (DD) de tal forma que los espigos encajen dentro los huecos pre-perforados en el borde inferior. Presione hacia abajo hasta que estén ajustados.

Aditamentos utilizados

DD	Espigo		x 2
-----------	--------	---	-----

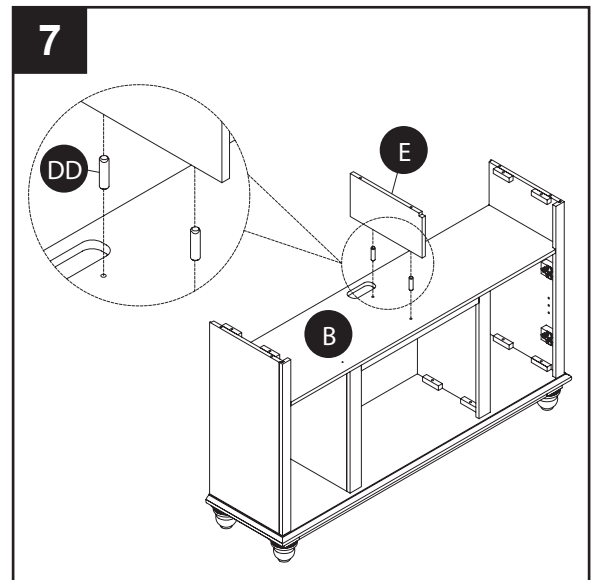

8. Teniendo el ensamblado en posición vertical, inserte seis espigos (DD) dentro de los huecos pre-perforados en la parte superior de los bordes del ensamblado. Deslice el panel superior (A) sobre los espigos (DD) de tal forma que los espigos encajen dentro los huecos pre-perforados en el lado inferior del panel superior (A). Inserte dos pernos (AA) a través de arandelas planas (BB), arandelas de seguridad (CC), los huecos pre-perforados en los bloques del borde, y dentro de los huecos pre-perforados en el panel superior (A). Apriete con destornillador de estrella (no incluido).

Repita el proceso sobre el lado opuesto.

Aditamentos utilizados

AA	Perno		x 4
BB	Arandela Plana		x 4
CC	Arandela de Seguridad		x 4
DD	Espigo		x 6

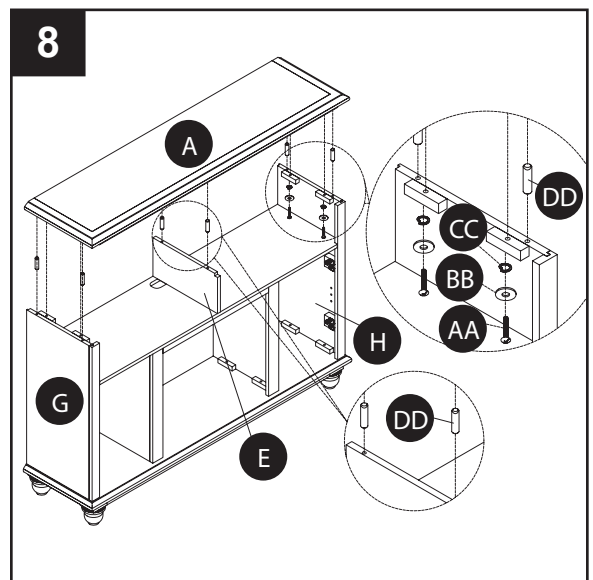

INSTRUCCIONES DE ENSAMBLAJE

9. Una el panel trasero superior (M) y los paneles traseros inferiores (L) insertando tornillos pequeños (EE) dentro de los huecos pre-perforados y apriételos mediante destornillador de estrella (no incluido).

Aditamentos utilizados

EE Tornillo  x 42

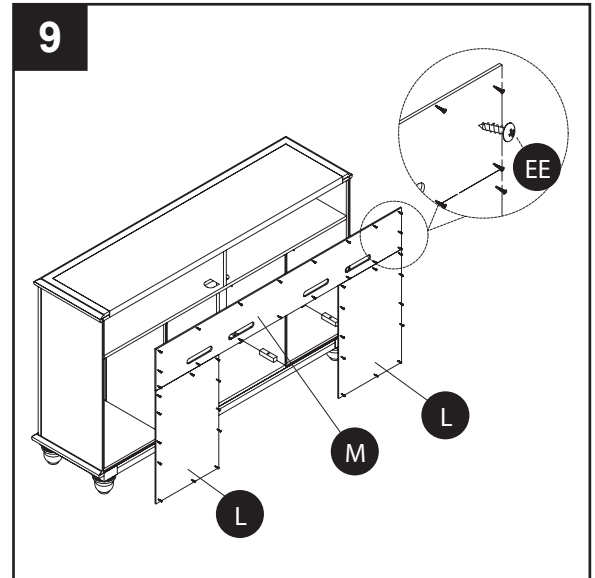

10. Inserte los soportes de repisa (HH) dentro de los huecos pre-perforados como se ilustra, manteniendo todos los soportes de repisa (HH) paralelos unos a otros. Coloque en posición las repisas ajustables (D), en cada lado del ensamblado.

Aditamentos utilizados

HH Soporte de Repisa  x 8

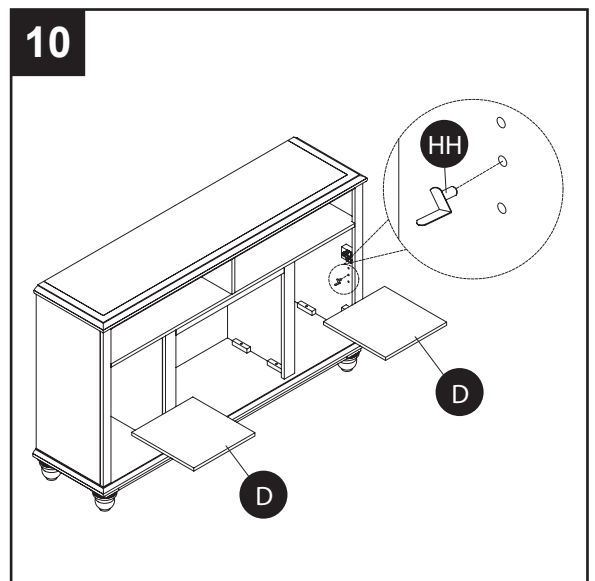

INSTRUCCIONES DE ENSAMBLAJE

11. Fije la puerta derecha del gabinete (P) a las bisagras sobre el ensamblado. Fije la perilla de la puerta del gabinete (GG) con un tornillo de perilla (FF), insertado a través del hueco pre-perforado en la puerta del gabinete derecho (P). Apriete con destornillador de estrella (no incluido).
Repita el proceso con la puerta izquierda del gabinete (N).

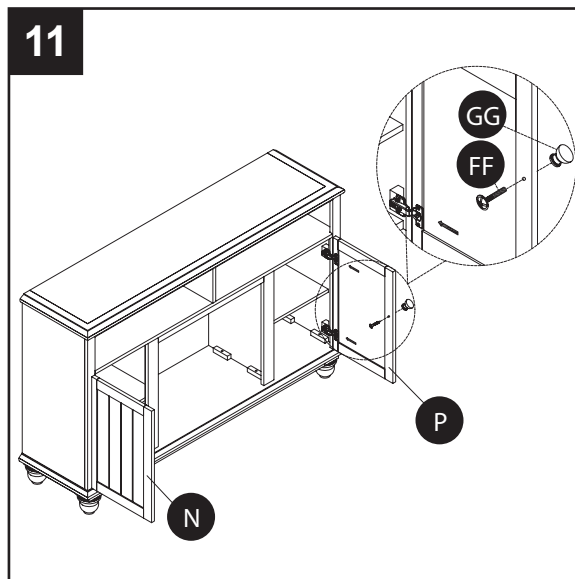

Aditamentos utilizados

GG	Perilla de la Puerta del Gabinete		x 2
FF	Tornillo de Perilla		x 2

CUIDADO Y MANTENIMIENTO

- Para mantener el acabado, debe limpiar con un paño suave levemente humedecido y dar brillo con un paño seco.
- Los muebles de madera no se deben arrastrar nunca por el piso. El esfuerzo adicional de arrastrar la unidad puede hacer que se astille el borde arrastrado o que se suelte una junta.

GARANTÍA LIMITADA DE UN AÑO

Si en el lapso de un año a partir de la fecha de compra original este artículo falla debido a un defecto en el material o la mano de obra, lo reemplazaremos o repararemos sin cargos a nuestra discreción. Para pedir piezas u obtener servicio de garantía, llame a al 1-877-447-4768, de lunes a viernes de 8:30 a.m. a 4:30 p.m., hora central estándar. Esta garantía no cubre defectos que sean producto de un uso incorrecto o anormal, uso indebido, accidente o alteración. No seguir todas las instrucciones del manual del propietario también anulará esta garantía. El fabricante no será responsable de daños accidentales o resultantes. Algunos estados no permiten la exclusión o limitación de los daños accidentales o resultantes, de modo que la exclusión o limitación de estos daños puede no aplicarse en su caso. Esta garantía le otorga derechos legales específicos, pero podría tener también otros derechos que varían según el estado.

Las variaciones en el color real de la madera y en los acabados que puedan ser producto de las características naturales de la madera, tales como patrones de vetas, rayas minerales y similares, no se consideran defectos. A medida que la madera continúa moviéndose y envejeciendo, usted puede observar estas leves diferencias en el color, incluso en distintas partes de una unidad. Nudos sanos y leves grietas superficiales son la verdadera personalidad de un mueble de madera de calidad.

LISTA DE PIEZAS DE REPUESTO

Para obtener piezas de repuesto, llame a nuestro Departamento de Servicio al Cliente al 1-877-447-4768, de lunes a viernes de 8:30 a.m. a 4:30 p.m., hora central estándar.

PIEZA	DESCRIPCIÓN	PIEZA #
A	Panel Superior	20-12-178
B	Repisa Superior	20-12-179
C	Base	20-12-180
D	Repisa Ajustable	20-12-181
E	Separador de la Repisa Superior	20-12-182
F	Riel para Repisa	20-12-183
G	Panel del Lado Izquierdo	20-12-184
H	Panel del Lado Derecho	20-12-185
J	Panel Interior Izquierdo	20-12-186
K	Panel Interior Derecho	20-12-187
L	Panel Trasero Inferior	20-12-188
M	Panel Trasero Superior	20-12-189
N	Puerta del Gabinete Izquierdo	20-12-190
P	Puerta del Gabinete Derecha	20-12-191
Q	Pata	20-12-192
R	Pata de la Mitad	20-12-193
AA	Perno	20-12-194
BB	Arandela Plana	20-12-195
CC	Arandela de Seguridad	20-12-196
DD	Espigo	20-12-197
EE	Tornillo	20-12-198
FF	Tornillo de Perilla	20-12-199
GG	Perilla de la Puerta del Gabinete	20-12-200
HH	Soporte de Repisa	20-12-201

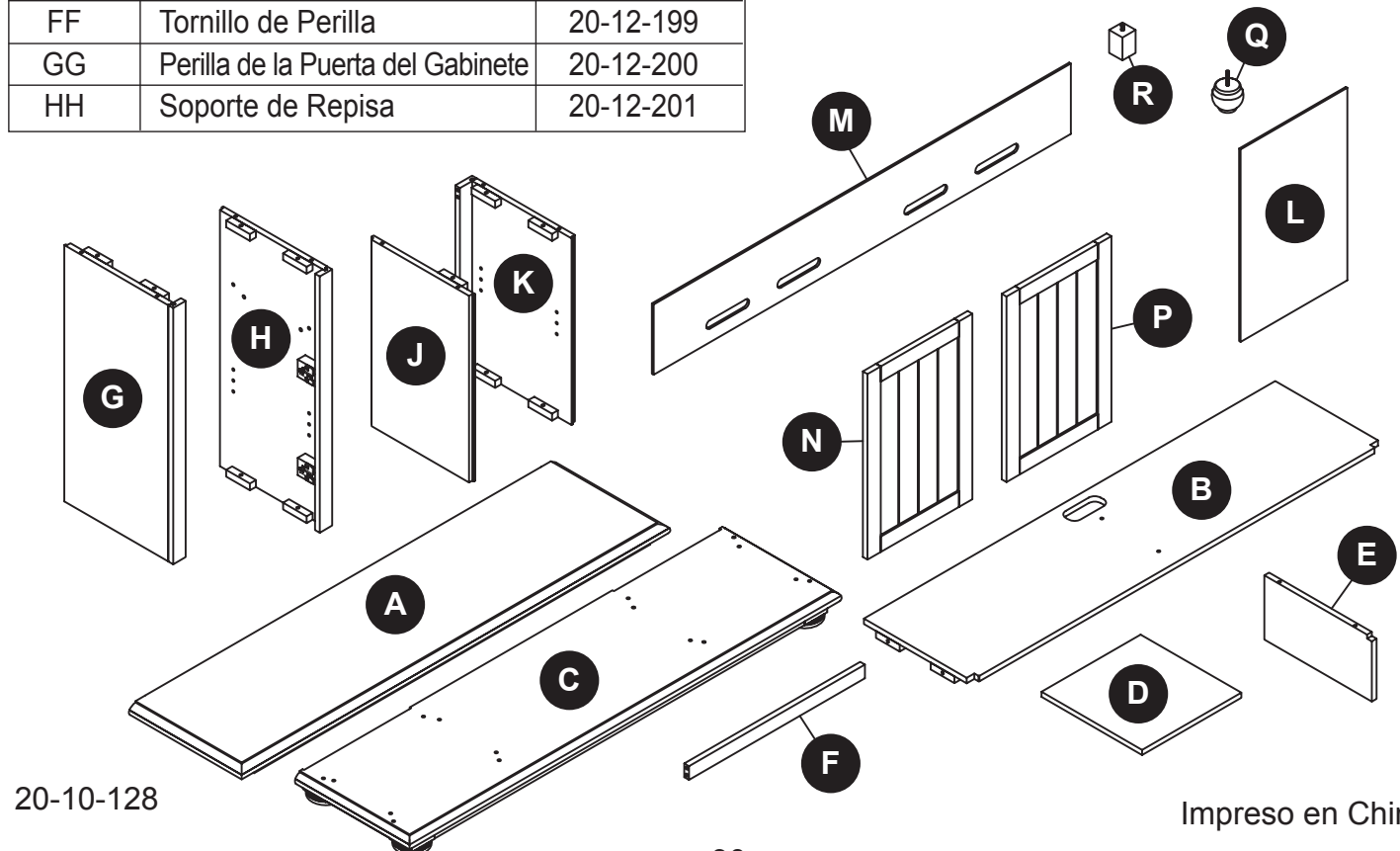
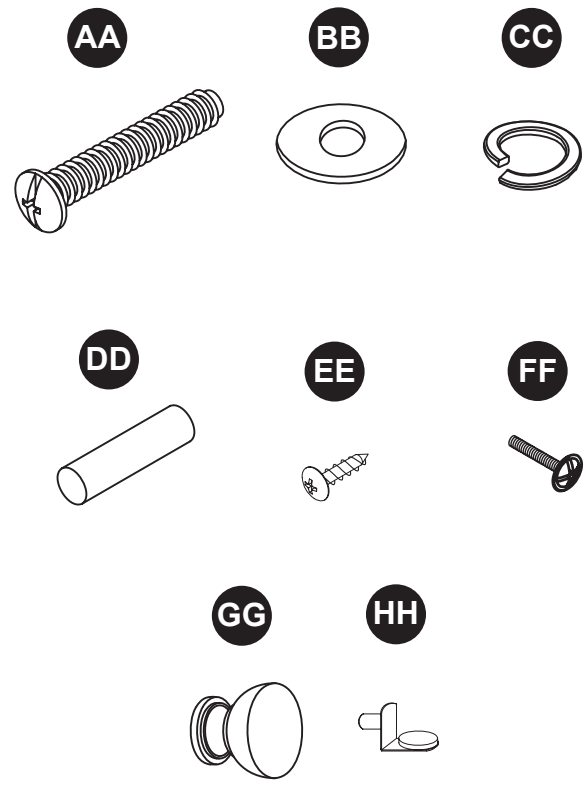



HERITAGE MEDIA MANTEL FOR 23 IN. FIREBOX

MODEL #23-29-65

Français p. 11

Español p. 21

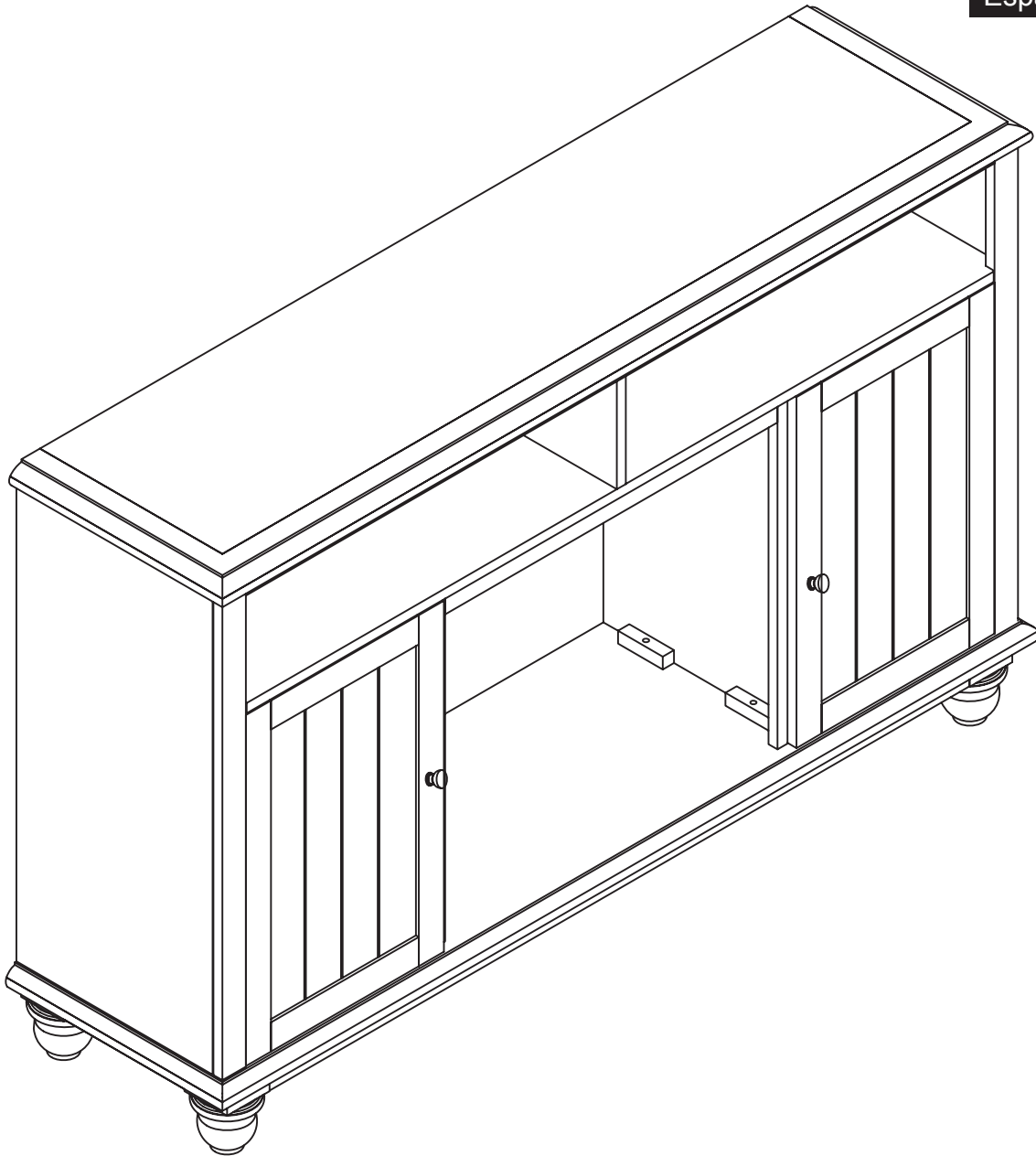

ATTACH YOUR RECEIPT HERE

Serial Number _____ Purchase Date _____







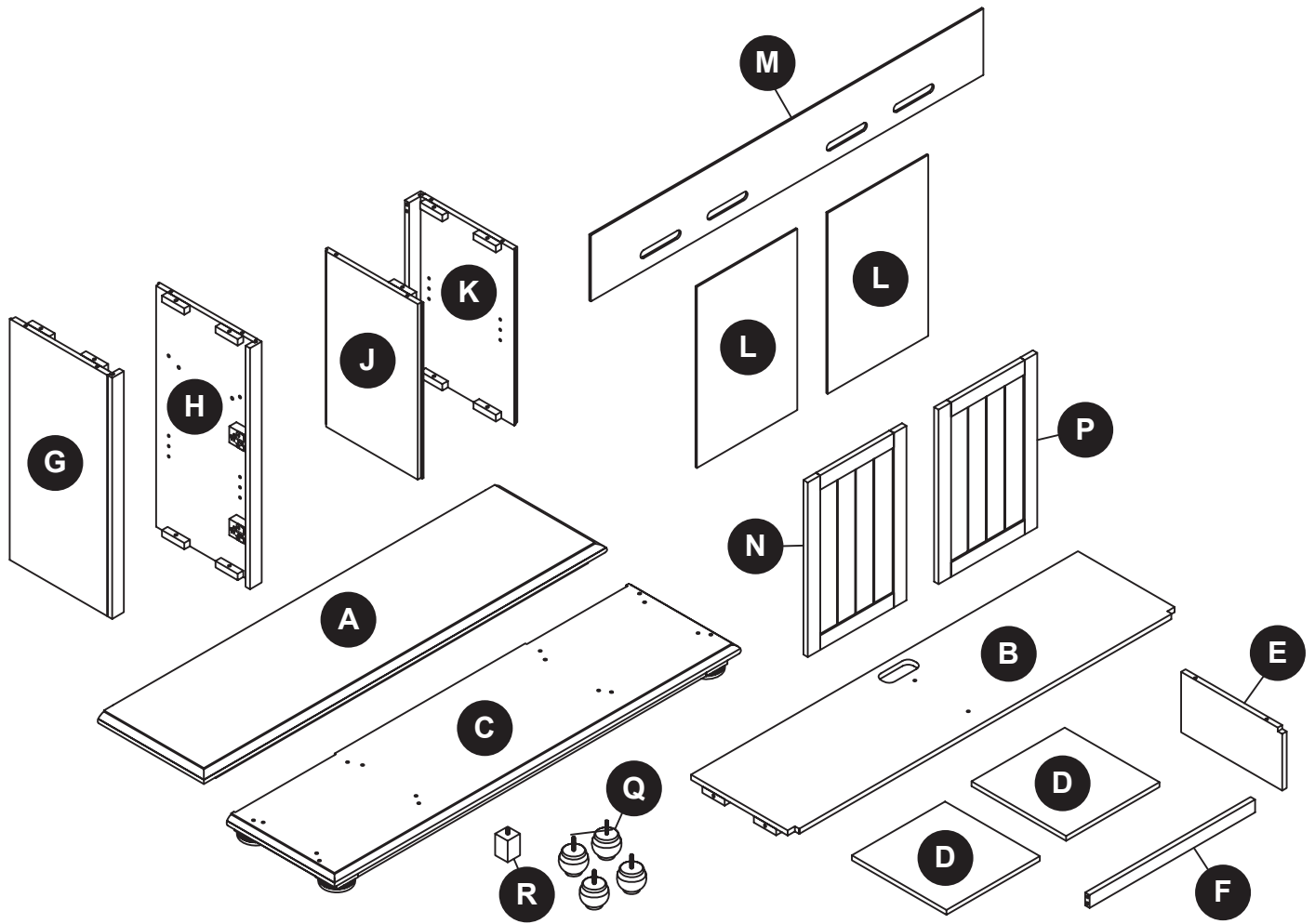

Questions, problems, missing parts? Before returning to your retailer, call our customer service department at 1-877-447-4768, 8:30 a.m. - 4:30 p.m., CST, Monday - Friday.

PACKAGE CONTENTS

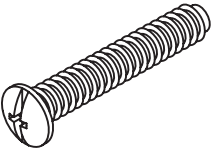
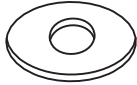

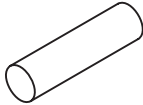
PART	DESCRIPTION	QUANTITY
A	Top Panel	1
B	Top Shelf	1
C	Base	1
D	Adjustable Shelf	2
E	Top Shelf Divider	1
F	Shelf Rail	1
G	Left Side Panel	1
H	Right Side Panel	1
J	Left Inner Panel	1
K	Right Inner Panel	1
L	Lower Back Panel	2
M	Upper Back Panel	1
N	Left Cabinet Door	1
P	Right Cabinet Door	1
Q	Leg	4
R	Middle Leg	1

HARDWARE CONTENTS (shown actual size)

AA	BB	CC	DD	EE	FF	GG	HH
							
Bolt	Flat Washer	Lock Washer	Dowel	Screw	Knob Screw	Cabinet Door Knob	Shelf Support
Qty. 20	Qty. 20	Qty. 20	Qty. 28	Qty. 42	Qty. 2	Qty. 2	Qty. 8

SAFETY INFORMATION

Please read and understand this entire manual before attempting to assemble, operate or install the product.

WARNING

- Mantel is heavy and should be assembled near its desired location.
- It is recommended that two people move the finished mantel to prevent injury.

PREPARATION

Before beginning assembly of product, make sure all parts are present. Compare parts with package contents list and hardware contents list. If any part is missing or damaged, do not attempt to assemble the product.

Estimated Assembly Time: 45 minutes

Tools Required for Assembly: Phillips screwdriver (not included).

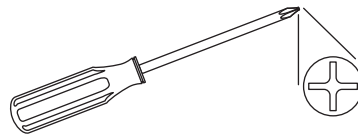

ASSEMBLY INSTRUCTIONS

1. Screw each of the four legs (Q) into the predrilled holes in each corner of the base (C). Screw middle leg (R) into predrilled hole in center brace of base (C).

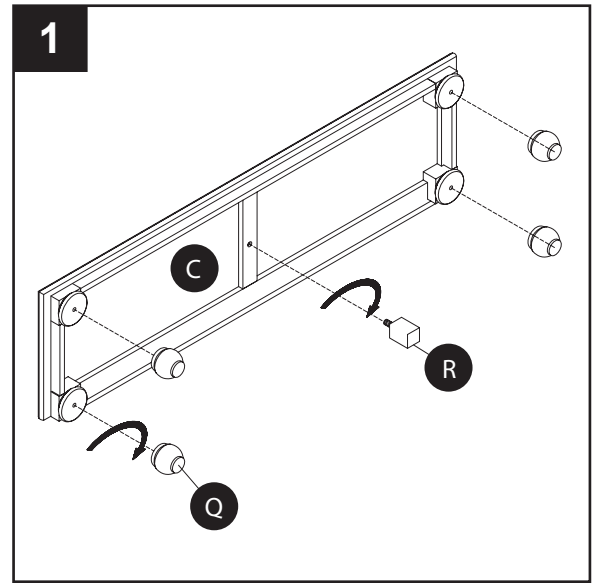



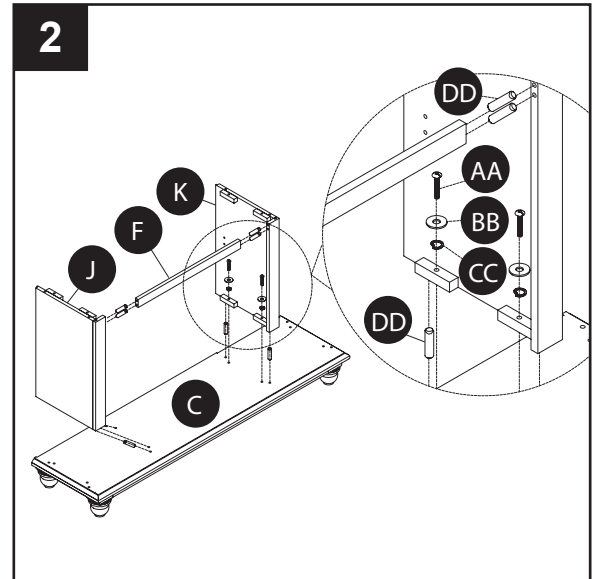

2. Insert two dowels (DD) into predrilled holes on each end of shelf rail (F). Slip one end of shelf rail (F) into predrilled holes in upper edge of left inner panel (J) and the other end into predrilled holes in upper edge of right inner panel (K). Press together until both joints are snug. Lay base (C) face up on a flat, level surface and insert four dowels (DD) into predrilled holes in center area of base (C). Slip panel assembly over dowels (DD) so that the dowels (DD) fit into predrilled holes in bottom edge of assembly. Insert two bolts (AA) through flat washers (BB), lock washers (CC), predrilled holes in edge blocks and into predrilled holes in base (C). Tighten with Phillips screwdriver (not included).



Repeat on opposite side.

Hardware Used

AA	Bolt		x 4
BB	Flat Washer		x 4
CC	Lock Washer		x 4
DD	Dowel		x 8

ASSEMBLY INSTRUCTIONS

3. Insert two dowels (DD) into predrilled holes in each end of top shelf (B). Slip one end of top shelf (B) into predrilled holes on inside face of left side panel (G) and the other end into predrilled holes on inside face of right side panel (H). Press together until both joints are snug.

Hardware Used

DD Dowel  x 4

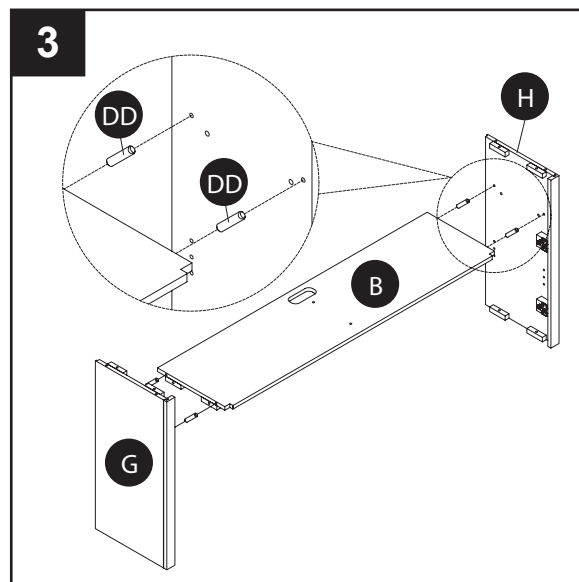

4. Insert four dowels (DD) into predrilled holes in base (C). Insert four dowels (DD) into predrilled holes in top edge of left and right inner panels (J&K). Set top shelf assembly over dowels (DD) in base (C) and inner panel assembly so that the dowels (DD) fit into predrilled holes in bottom edges of left and right side panels (G&H) and underside of top shelf (B). Press down until all joints are snug.

Hardware Used

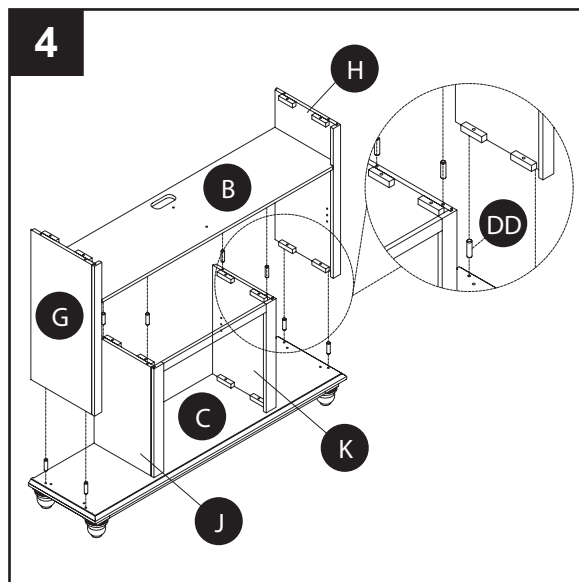

DD Dowel  x 8



ASSEMBLY INSTRUCTIONS

5. Insert two bolts (AA) through flat washers (BB), lock washers (CC), predrilled holes in edge blocks and into predrilled holes in base (C). Tighten with Phillips screwdriver (not included). Repeat on opposite side.

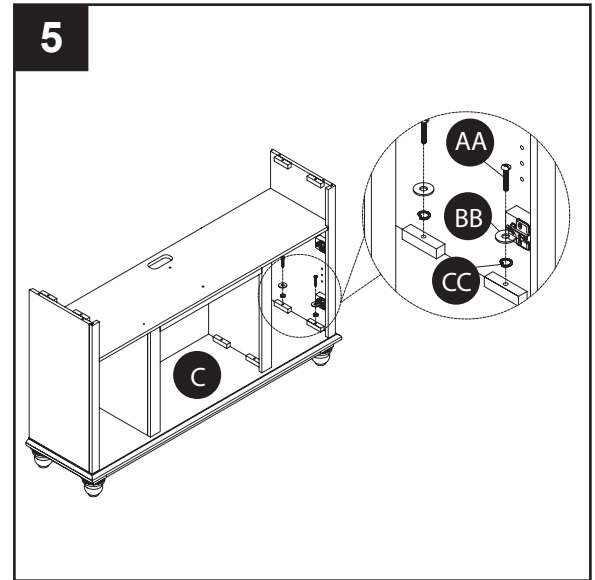

Hardware Used

AA	Bolt		x 4
BB	Flat Washer		x 4
CC	Lock Washer		x 4



6. Lay assembly on its back. Insert four bolts (AA) through flat washers (BB), lock washers (CC), predrilled holes in edge blocks and into predrilled holes on right side of assembly as illustrated. Tighten with Phillips screwdriver (not included). Repeat on opposite end.

Hardware Used

AA	Bolt		x 8
BB	Flat Washer		x 8
CC	Lock Washer		x 8

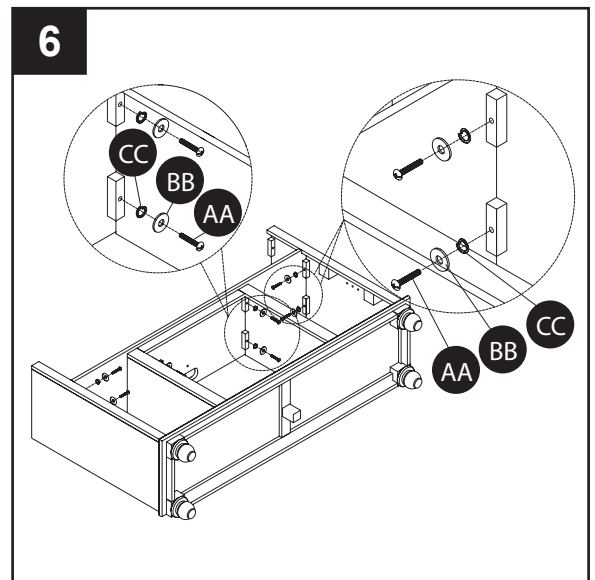

ASSEMBLY INSTRUCTIONS

7. With assembly sitting upright, insert two dowels (DD) into predrilled holes in top of top shelf (B). Slip top shelf divider (E) over dowels (DD) so that the dowels fit into predrilled holes in bottom edge. Press down until snug.



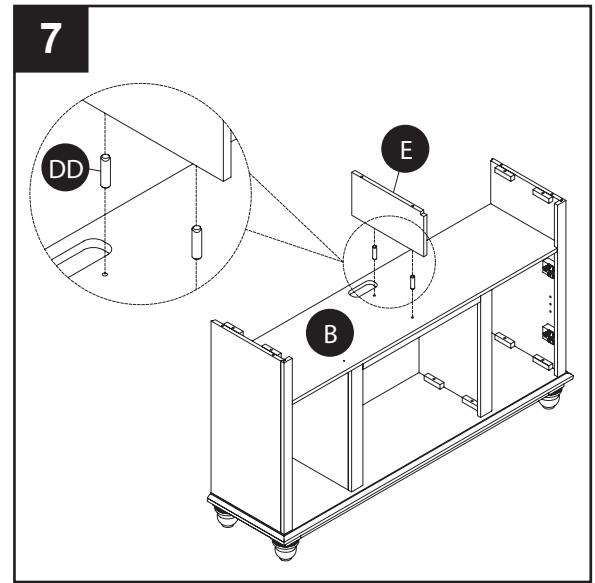

Hardware Used

DD	Dowel		x 2
-----------	-------	---	-----



8. With assembly sitting upright, insert six dowels (DD) into predrilled holes in top of edges of assembly. Slip top panel (A) over dowels (DD) so that the dowels fit into predrilled holes in underneath side of top panel (A). Insert two bolts (AA) through flat washers (BB), lock washers (CC), predrilled holes in edge blocks, and into predrilled holes in top panel (A). Tighten with Phillips screwdriver (not included). Repeat on opposite side.

Hardware Used

AA	Bolt		x 4
BB	Flat Washer		x 4
CC	Lock Washer		x 4
DD	Dowel		x 6

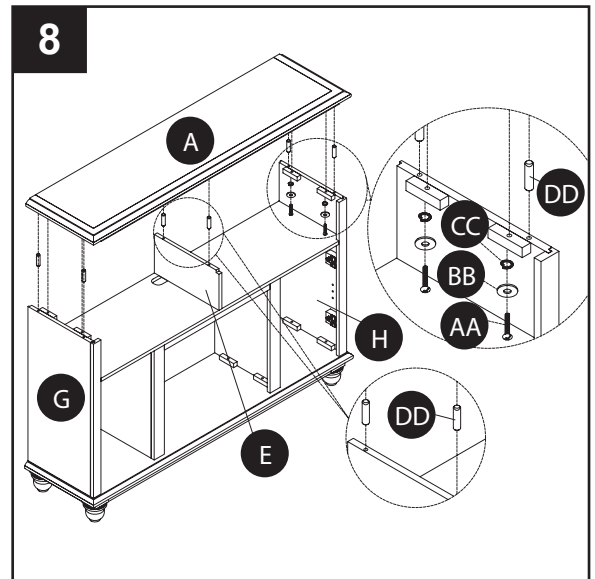

ASSEMBLY INSTRUCTIONS

9. Attach upper back panel (M) and lower back panels (L) by inserting screws (EE) into predrilled holes and tightening with Phillips screwdriver (not included).

Hardware Used

EE Screw  x 42

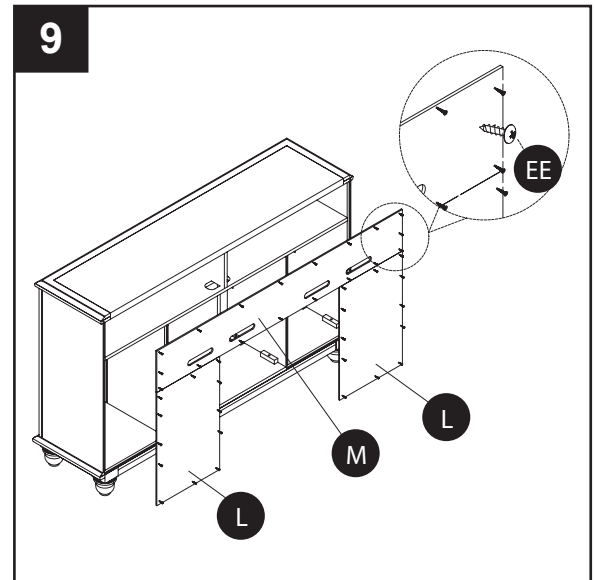

10. Insert shelf supports (HH) into predrilled holes as illustrated, keeping all shelf supports (HH) parallel to each other. Lay adjustable shelves (D) in place on each side of assembly.

Hardware Used

HH Shelf Support  x 8

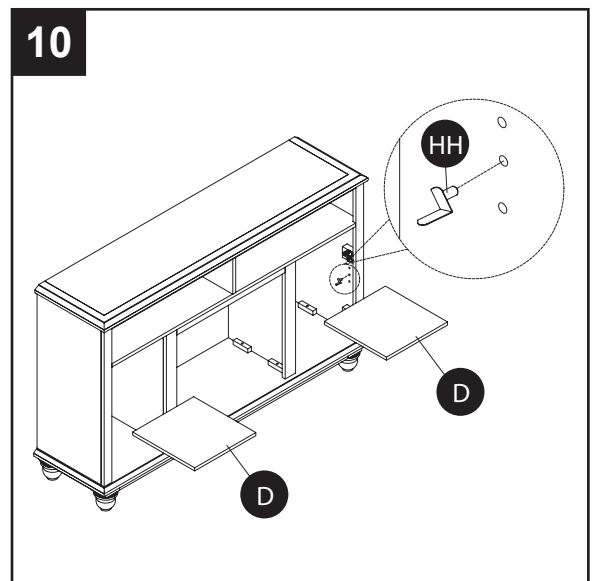

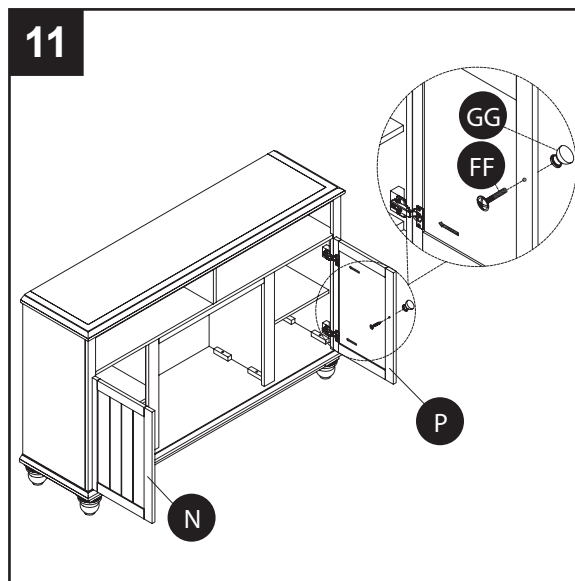

ASSEMBLY INSTRUCTIONS

11. Attach right cabinet door (P) to hinges on assembly. Attach cabinet door knob (GG) with knob screw (FF) inserted through predrilled hole in right cabinet door (P). Tighten with Phillips screwdriver (not included). Repeat with left cabinet door (N).

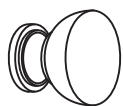

Hardware Used

	Cabinet Door Knob		x 2
	Knob Screw		x 2

CARE AND MAINTENANCE

- To maintain the finish, clean with a soft, slightly damp cloth and buff with a dry cloth.
- Wood furniture should never be dragged across a floor. The added stress from dragging the unit may cause the dragged edge to splinter or it may cause a joint to loosen.

ONE YEAR LIMITED WARRANTY

If within one year from the date of original purchase this item fails due to a defect in material or workmanship, we will replace or repair at our option, free of charge. To order parts or to obtain warranty service, call 1-877-447-4768, Monday – Friday, 8:30 a.m. – 4:30 p.m., CST. This warranty does not cover defects resulting from improper or abnormal use, misuse, accident, or alteration. Failure to follow all instructions in the owner's manual will also void this warranty. The manufacturer will not be liable for incidental or consequential damages. Some states do not allow the exclusion or limitation of incidental or consequential damages, so the above limitation or exclusion of incidental or consequential damages may not apply to you. This warranty gives you specific legal rights, and you may also have other rights which vary from state to state.

Variations in actual wood color and finishes which may result from natural characteristics of the wood, such as grain patterns, mineral streaks and the like, are not considered defects. As wood continues to move and age you may notice these slight differences in color, even on different parts of any individual unit. Sound knots and slight surface cracks are true personality of a quality piece of wood furniture.

REPLACEMENT PARTS LIST

For replacement parts, call our customer service department at 1-877-447-4768, 8:30 a.m. - 4:30 p.m., CST, Monday - Friday.

PART	DESCRIPTION	PART #
A	Top Panel	20-12-178
B	Top Shelf	20-12-179
C	Base	20-12-180
D	Adjustable Shelf	20-12-181
E	Top Shelf Divider	20-12-182
F	Shelf Rail	20-12-183
G	Left Side Panel	20-12-184
H	Right Side Panel	20-12-185
J	Left Inner Panel	20-12-186
K	Right Inner Panel	20-12-187
L	Lower Back Panel	20-12-188
M	Upper Back Panel	20-12-189
N	Left Cabinet Door	20-12-190
P	Right Cabinet Door	20-12-191
Q	Leg	20-12-192
R	Middle Leg	20-12-193
AA	Bolt	20-12-194
BB	Flat Washer	20-12-195
CC	Lock Washer	20-12-196
DD	Dowel	20-12-197
EE	Screw	20-12-198
FF	Knob Screw	20-12-199
GG	Cabinet Door Knob	20-12-200
HH	Shelf Support	20-12-201

