

# Owner's Manual

## CONTACT US

Questions? Need parts?

We are here to help!

Permasteel Customer Service

Tel: 888-287-0735

Fax: 909-287-0733

Email: [service@permasteel.net](mailto:service@permasteel.net)

Monday-Friday

8:00am-5:00pm (Pacific Standard Time)



STEEL 80QT COOLER

MODEL#PS-206

## **ASSEMBLY INSTRUCTIONS:**

### TOOLS REQUIRED:

#2 Phillips screwdriver

Allen wrench

Please read the cooler manual carefully and assemble according to following steps.

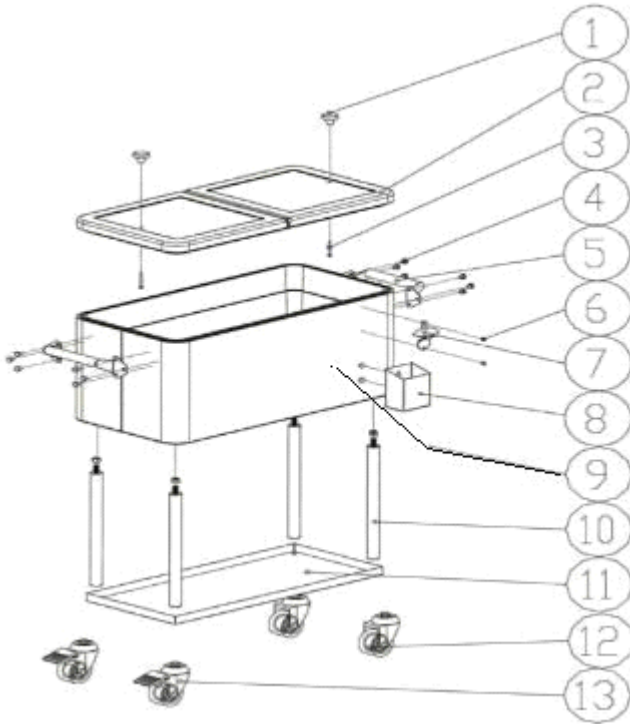

Item	Description	Quantity
1	Lid Handle	2
2	Lid	2
3	M5*40 Screw	2
4	M6*12 Allen Scre	12
5	Handle	2
6	M6*12 Allen screw	2
7	Bottle Opener	1
8	Bottle-cap catcher	1
9	Basin	1
10	leg	4
11	bottom shelf	1
12	wheel without lock	2
13	wheel with lock	2
	M6 Allen wrench	1

1. Please make sure all parts are accounted for before beginning assembly.
2. Place main basin up-side down on clean soft surface insert each leg(part 10) and rotate into main basin by hand, after 4 legs are installed, then put the bottle tray on each leg, then rotate each wheel(parts 12&13) into the leg with an open wrench
3. Turn over entire assembly right side-up press caster brake lever to lock casters (part 12) insert right handle (part 5) into bracket attach using 6 pcs M6\*12 Allen screws (parts 3) with a Allen wrench. Repeat for left handle.
4. Attach bottle-cap catcher (parts 9) to main basin by sliding it down over 2 preinstalled bolts,
5. Attach bottle opener (parts 7) to main basin using 2pcs M6\*12 Allen screws with a Allen screwdriver.
6. Attach 2pcs lid handles (parts 1) to cooler lid by using 2pcs 5/32x1/2" screws with a Phillips screwdriver.
7. Clean inside of cooler completely with soft dry towel. Place cooler lid (2) on top of main basin (A) your cooler is now ready for use.