

This Owner's Manual is provided and hosted by Appliance Factory Parts.



Permasteel PS-203-F1 Owner's Manual

[Shop genuine replacement parts for Permasteel
PS-203-F1](#)

PARTS LIST:



Item	Description	Qty
1	Caster	2
2	M8X16 Hex Socket Bolt	8
3	M8 washer	8
4	Legs	4
5	Main Body	1
6	Lid	1
7	Lid Handle	2
8	Washer	2
9	M5X35 Phillips Screw	2
10	M6X16 Hex Socket Bolt	10
11	Handle	2
12	Bottle Opener	1
13	Bottle Cap Catcher	1
14	M6X16 Shoulder Bolt	2
15	Bottom Panel	1
16	Caster W / Brake	2

Note: Parts 7, 8 & 9 are attached to lid (part 6)
Part 14 is attached to main body (part 5)

TOOLS REQUIRED: Allen wrench

[Find Your Permasteel Other Parts - Select From 22 Models](#)

----- Manual continues below -----

Owner's Manual

CONTACT US

Questions? Need parts?

We are here to help!

Permasteel Customer Service

Tel: 888-287-0735

Fax: 909-287-0733

Email: service@permasteel.net

Monday-Friday

8:00am-5:00pm (Pacific Standard Time)

Owner's Manual



STEEL 80QT COOLER

MODEL#PS-203-F1

OWNERS MANUAL

Model PS-203-F1

Please do not return this product to place of purchase. For technical assistance on assembly or replacement parts, call PERMASTEEL INC.

Toll free at 888-287-0735

8:00am to 5:00pm PST Monday to Friday; or for expedited replacement parts order, fax the attached completed part replacement form to 909-287-0733; or email service@permasteel.net for assistance.

PARTS LIST:

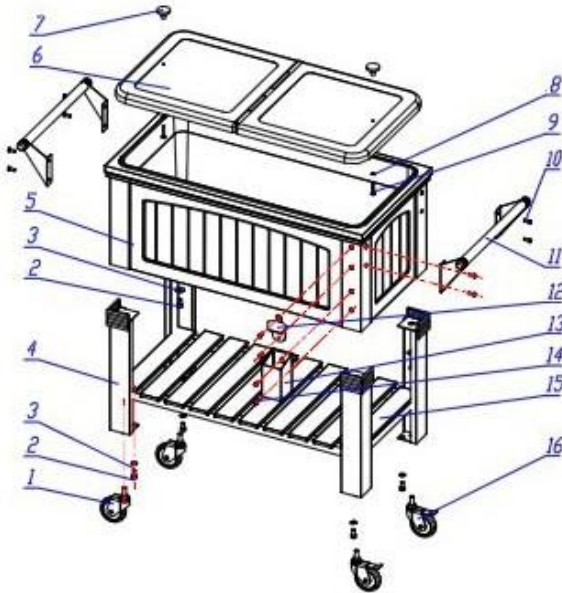

Item	Description	Qty
1	Caster	2
2	M8X16 Hex Socket Bolt	8
3	M8 washer	8
4	Legs	4
5	Main Body	1
6	Lid	1
7	Lid Handle	2
8	Washer	2
9	M5X35 Phillips Screw	2
10	M6X16 Hex Socket Bolt	10
11	Handle	2
12	Bottle Opener	1
13	Bottle Cap Catcher	1
14	M6X16 Shoulder Bolt	2
15	Bottom Panel	1
16	Caster W / Brake	2

Note: Parts 7, 8 & 9 are attached to lid (part 6)
Part 14 is attached to main body (part 5)

TOOLS REQUIRED: Allen wrench
Open end wrench
Phillips screwdriver

Fig. A

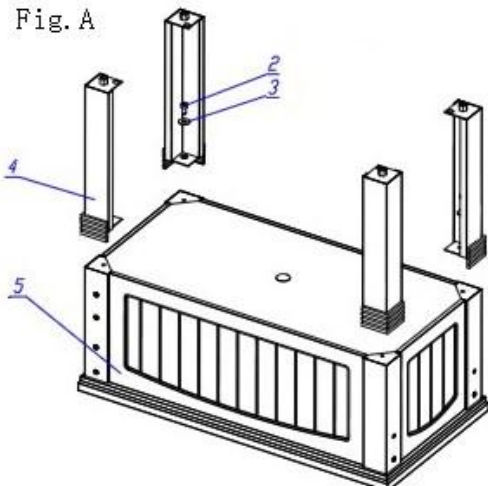
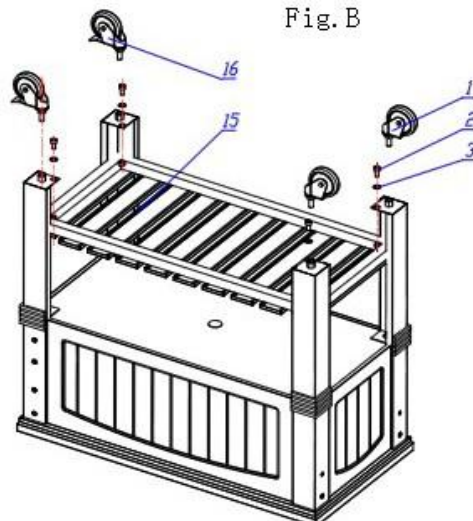
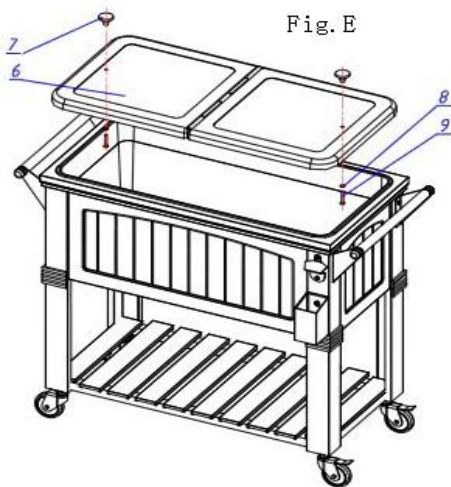
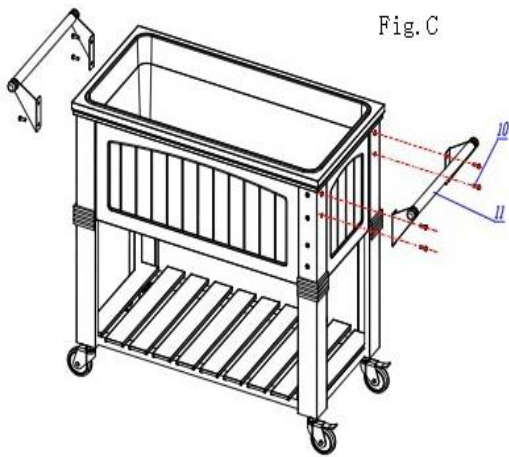

Fig. B





ASSEMBLY INSTRUCTIONS

1. Please make sure all parts are accounted for before beginning assembly.
2. Fig A: Place main body (part 5) up-side down on clean soft surface attach legs (part 4) to main body (part 5) using 4pcs M8X16 hex socket bolt (part 2) and 4pcs M8 washer (part 3)
3. Fig B: Attach bottom panel (part 15) to legs (part 4) using 4pcs. M8X16 hex socket bolt (part 2) and 4pcs. M8 washer (part 3) Attach caster (Part 1) and Caster w / brake (part 16) to legs (part 4).
4. Fig C: Turn over entire assembly right side-up, attach handles (part 11) to main body (part 5) using 8pcs. M16X16 hex socket bolt (part 10)
5. Fig D: Attach bottle opener (part 12) to main body (part 5) using 2pcs. M6X16 hex socket bolt (part 10). Attach bottle cap catcher (part 13) to main body by sliding down on pre-installed M6X16 shoulder bolts (part 14)
6. Fig E: Turn lid (part 6) over and detach M5X35 Phillips screw and washer (parts 8 & 9) from lid handle (part 7) and re-attach with lid handle on outside.
7. Clean inside of cooler completely with soft dry towel, your cooler is now ready to use.