

This Owner's Manual is provided and hosted by [Appliance Factory Parts](#).



FISHER PRICE CLG99 Owner's Manual

[Shop genuine replacement parts for FISHER PRICE
CLG99](#)



[Find Your FISHER PRICE Ride On Parts - Select From 999 Models](#)

----- Manual continues below -----

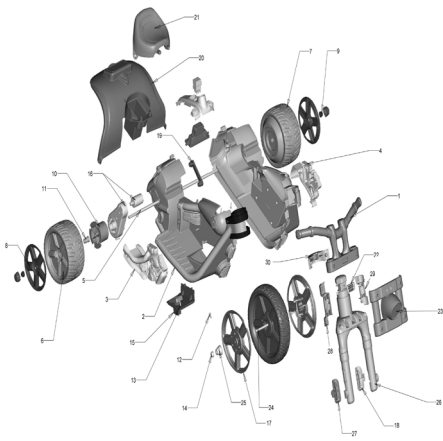

CLG99 Harley Rocker Preschool	
Age Range:	12-36 Months
Weight Limit:	50 Lbs.
Surfaces:	Hard Surfaces
Speed:	2.5 MPH Forward/Reverse
Colors:	Red Body, Black Wheels
Intro:	2015
Suggested Retail:	\$138.21
Box Dimensions:	25.375" x 28.375" x 14.125"
Warranty:	One Year Vehicle Six Months Battery



Item	Part #	Description	QTY	Item	Part #	Description	QTY
1	X0067-2349	Handlebar for Harley Davidson	1	26	X0067-9239	Fork / Front Wheel Assembly	1
2	N/A	Body	1	27	X0067-2259	Front Axle Retainer (right) for Harley	1
3	X0067-2659	Engine (right) for Harley Davidson	1	28	In Parts Bag	Headlight Retainer Right	1
4	X0067-2669	Engine (left) for Harley Davidson	1	29	In Parts Bag	Headlight Retainer Left	1
5	P5065-4519	Rear Axle for Harley Rocker	1	30	In Parts Bag	Handlebar Bracket	1
6	P5065-2159	Right Rear Wheel (black) for Harley	1				
7	P5065-2169	Left Rear Wheel (black) for Harley	1				
8	X0067-2499	Rear Hubcap (Gray)	2				
9	00801-1939	Cap Nut .437 - Black	2				
10	74460-2249	Wheel Driver 10 RIB	1				
11	73610-2699	Bushing .437 Long Black	4				
12	00801-1450	Cable Clamp	2				
13	X0067-9539	Footboard Assembly*	1				
14	0801-0604	.354 Black Retainer/Cap Nut.	2				
15	00801-0873	Control Switch w/black buttons*	1				
16	00968-1900	#3R Motor Gearbox Assm w/w conn.	1				
17	X0067-2279	Front Wheel Cover for Harley (Silver)	1				
18	X0067-2289	Front Axle Retainer (left) for Harley	1				
19	X0067-2689	Motor Clamp for Harley Davidson	1				
20	3900-3871	Rear Fender for Harley (CLG99)	1				
21	P5065-2309	Seat for Harley Rocker	1				
22	00801-1503	PW Emblem	1				
23	3900-1427	Headlight w/Logo for Harley Davidson	1				
24	P5065-4529	Front Axle for Harley Rocker	1				
25	X0067-2229	Front Wheel Spacer for Harley	1				

Part #	Description	QTY
00801-0538	Footswitch - 3 pin*	1
P5065-3739	Wiring Harness for Harley Rocker*	1
00968-1720	# 3 Motor Pinion Assm*	1
74550-3279	Gearbox 3R w/ Insert*	1
00801-1900	6V 4 Amp internal fuse battery	1
00801-1781	Charger 4amp fused - 6volt	1
74230-4129	Battery Retainer	1
P5065-9469	Hardware Bag for Harley Rocker	1
X0067-9479	Parts Bag for Harley Davidson	1
3900-3769	Label Sheet for Harley Rocker	1

*When repairing parts for warranty, please refer to Additional Labor Rates under Reference Material on the B2B

Bold and underlined parts are to be purchased and installed by Service Centers only. These items may not be sold directly to consumers by Service Centers or Fisher.